



TLV. CO., LTD.



Instruction Manual

PowerTrap[®]

GP10L/GT10L
GP10M/GT10M
GP14M/GT14M

Contents

Introduction.....	2
Safety Considerations	3
General Description.....	5
Application.....	5
Operation.....	6
Specifications	7
Configuration	7
Installation	9
Open System Piping (Steam System Example).....	9
Closed System Piping (Steam System Example).....	10
Installation Procedure.....	10
Sizing the Condensate Receiver/Reservoir.....	16
Installing Several PowerTrap Units in Parallel	19
Installation and Maintenance Space	20
Anchoring the Body	20
Maintenance Space.....	20
Operation and Periodic Inspection	21
Operation.....	21
Periodic Inspection and Diagnosis	22
Disassembly/Reassembly	24
Replacement Parts.....	25
Recommended Tools List for Disassembly/Reassembly	26
1. Removing/Reattaching the Body from/to the Cover	27
2. Removing/Reattaching the Float	28
3. Separating/Rejoining the Trap Rod and Trap Unit (GT10L/GT10M/GT14M only)	28
4. Removing/Reattaching the Trap Unit (GT10L/GT10M/GT14M only)	29
5. Removing/Reattaching the Snap-action Unit.....	30
6. Removing/Reinstalling the Motive Medium Intake and Exhaust Valves.....	30
7. Removing/Reinstalling the Motive Medium Intake and Exhaust Valve Seats	31
Troubleshooting.....	32
Determining the Problem from the Symptoms.....	32
Types of Failure and their Causes	33
Causes and Corrective Measures	34
Product Warranty	37
Service	38

Introduction

Thank you for purchasing the **TLV. PowerTrap**.

This product has been thoroughly inspected before being shipped from the factory. When the product is delivered, before doing anything else, check the specifications and external appearance to make sure nothing is out of the ordinary. Also be sure to read this manual carefully before use and follow the instructions to be sure of using the product properly.







If detailed instructions for special order specifications or options not contained in this manual are required, please contact **TLV** for full details.

This instruction manual is intended for use with the model(s) listed on the front cover. It is necessary not only for installation, but for subsequent maintenance, disassembly/reassembly and troubleshooting. Please keep it in a safe place for future reference.

Safety Considerations

- Read this section carefully before use and be sure to follow the instructions.
- Installation, inspection, maintenance, repairs, disassembly, adjustment and valve opening/closing should be carried out only by trained maintenance personnel.
- The precautions listed in this manual are designed to ensure safety and prevent equipment damage and personal injury.
For situations that may occur as a result of erroneous handling, three different types of cautionary items are used to indicate the degree of urgency and the scale of potential damage and danger: DANGER, WARNING and CAUTION.
- The three types of cautionary items above are very important for safety: be sure to observe all of them as they relate to installation, use, maintenance and repair.
Furthermore, TLV accepts no responsibility for any accidents or damage occurring as a result of failure to observe these precautions.

Symbols

	Indicates a DANGER, WARNING or CAUTION item.
 DANGER	Indicates an urgent situation which poses a threat of death or serious injury
 WARNING	Indicates that there is a potential threat of death or serious injury
 CAUTION	Indicates that there is a possibility of injury or equipment/product damage
 WARNING	NEVER apply direct heat to the float. The float may explode due to increased internal pressure, causing accidents leading to serious injury or damage to property and equipment.
 CAUTION	Install properly and DO NOT use this product outside the recommended operating pressure, temperature and other specification ranges. Improper use may result in such hazards as damage to the product or malfunctions that may lead to serious accidents. Local regulations may restrict the use of this product to below the conditions quoted.
	Use hoisting equipment for heavy objects (weighing approximately 20 kg (44 lb) or more). Failure to do so may result in back strain or other injury if the object should fall.
	Take measures to prevent people from coming into direct contact with product outlets. Failure to do so may result in burns or other injury from the discharge of fluids.
	When disassembling or removing the product, wait until the internal pressure equals atmospheric pressure and the surface of the product has cooled to room temperature. Disassembling or removing the product when it is hot or under pressure may lead to discharge of fluids, causing burns, other injuries or damage.

Safety considerations are continued on the next page.

 CAUTION	<p>Be sure to use only the recommended components when repairing the product, and NEVER attempt to modify the product in any way. Failure to observe these precautions may result in damage to the product and burns or other injury due to malfunction or the discharge of fluids.</p>
	<p>Do not use excessive force when connecting threaded pipes to the product. Over-tightening may cause breakage leading to fluid discharge, which may cause burns or other injury.</p>
	<p>Use only under conditions in which no freeze-up will occur. Freezing may damage the product, leading to fluid discharge, which may cause burns or other injury.</p>
	<p>Use only under conditions in which no water hammer will occur. The impact of water hammer may damage the product, leading to fluid discharge, which may cause burns or other injury.</p>
	<p>Take measures to ensure the proper handling, such as recovery or dilution, of hazardous fluids discharged at product outlets. Outflow of fluid or fluid leaks may lead to hazards such as flammable conditions or corrosion, which may result in injury, fires, damage or other accidents.</p>

General Description

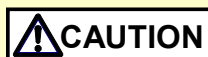

Install properly and **DO NOT** use this product outside the recommended operating pressure, temperature and other specification ranges. Improper use may result in such hazards as damage to the product or malfunctions which may lead to serious accidents. Local regulations may restrict the use of this product to below the conditions quoted.

Application

The **PowerTrap** is used to discharge liquid from vacuum-pressure or low-pressure areas to high-pressure areas, or from lower to higher elevations.

The GT model is the same as the GP, but with an additional steam trap function, making it suitable for use in instances in which the inlet pressure may alternately be lower than or higher than the outlet pressure.

There are two types of delivery systems (piping methods): the closed system and the open system. Use of the GT model or the GP model is determined by the type of system.

Check to make sure that the **PowerTrap** model that has been purchased is suitable for use on the type of system that is being planned for installation.

Type of System	Closed System	Open System
System Overview		
Benefits	<ul style="list-style-type: none"> · No need for external steam trap (GT model features built-in trap) · No flash steam discharge · Small reservoir · Use with vacuum equipment possible 	<ul style="list-style-type: none"> · Collection of condensate from multiple equipment possible · Can be used where trap is lower than receiver, such as equipment situated near grade (providing there is sufficient differential pressure)
Notes	<ul style="list-style-type: none"> · Only one piece of equipment possible per system · Equipment has minimum height requirement to ensure that condensate flows naturally, by gravity (GT10M: approx. 0.3 m (12 in), GT10L: approx. 0.3 m or 0.5 m (12 or 20 in) GT14M: approx. 0.35 m (14 in)) 	<ul style="list-style-type: none"> · Separate steam trap required for each piece of equipment · Requires venting pipe to discharge flash steam to atmosphere
Model	Mechanical pump with built-in trap GT10L/GT10M/GT14M Where there is ALWAYS a negative pressure differential (e.g. vacuum equipment), GP10L/GP10M/GP14M can be used	Mechanical pump GP10L/GP10M/GP14M

Operation



Take measures to prevent people from coming into direct contact with product outlets. Failure to do so may result in burns or other injury from the discharge of fluids.

- (1) When condensate flows from the condensate inlet pipe through the inlet check valve into the body of the unit, the air in the body escapes through the exhaust valve (which equalizes the internal pump pressure to the pressure of the condensate source) and the float rises, as shown in (1) below.
 - In the case of the GT, the main valve on the trap unit opens as the float rises. When $P_1 > P_b$ (when the inlet pressure (P_1) is greater than the back pressure (P_b)), the condensate passes through the outlet check valve and is discharged through the condensate outlet pipe (normal trapping function).
 - When $P_1 \leq P_b$ for both the GP and GT models, the condensate is not discharged and collects in the body of the unit.
- (2) When the float rises to its high level, the push rod on the snap-action unit rises quickly, simultaneously closing the exhaust valve and opening the intake (motive medium) valve. The pressure supplied by the motive medium causes the internal pressure in the unit to become greater than the back pressure. The inlet check valve closes and the outlet check valve is pushed open, thus discharging the condensate in the unit through the outlet pipe, as shown in (2) below.
- (3) As a result of the condensate in the unit being discharged, the water level in the unit drops and the float descends. When the float reaches its low level, the push rod on the snap-action unit moves down quickly, simultaneously opening the exhaust valve and closing the intake (motive medium) valve and the status reverts to that shown in (1) below.

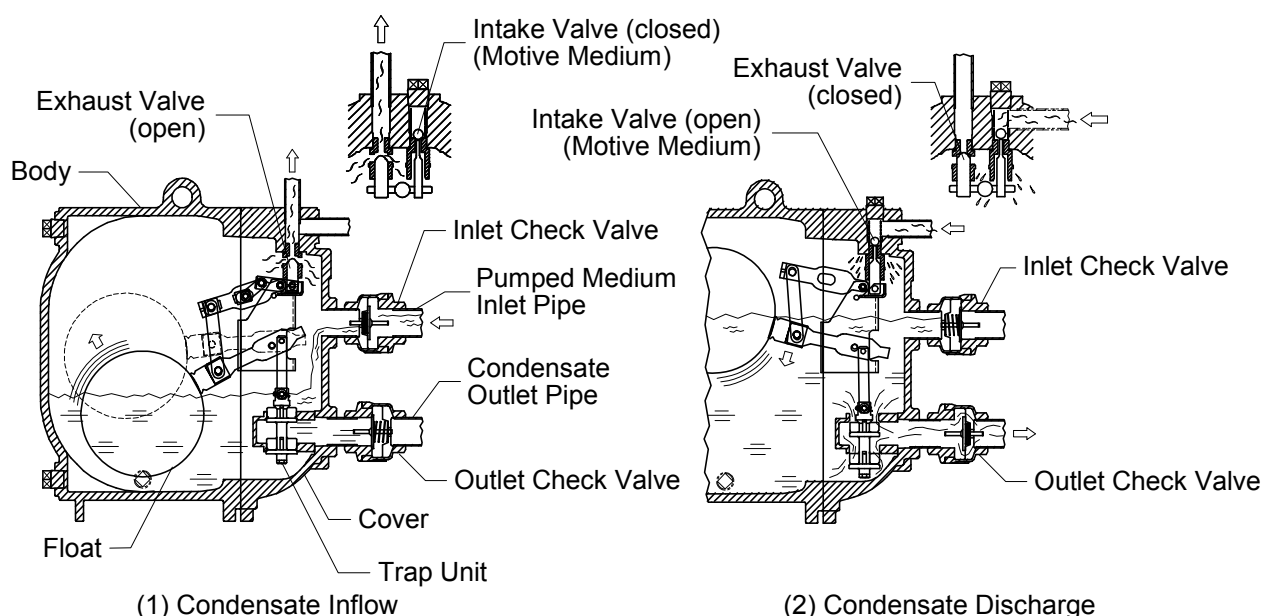

Specifications



Install properly and **DO NOT** use this product outside the recommended operating pressure, temperature and other specification ranges. Improper use may result in such hazards as damage to the product or malfunctions which may lead to serious accidents. Local regulations may restrict the use of this product to below the conditions quoted.



Use only under conditions in which no freeze-up will occur. Freezing may damage the product, leading to fluid discharge, which may cause burns or other injury.

Refer to the product nameplate for detailed specifications.

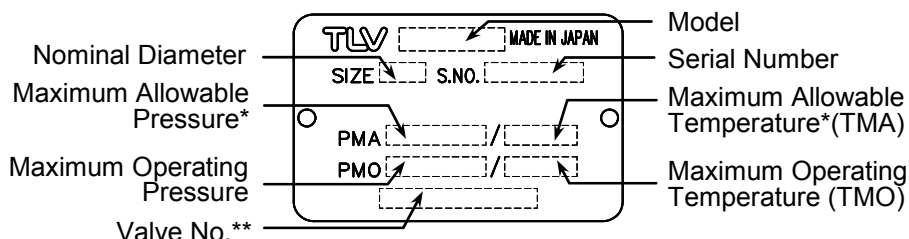

* Maximum allowable pressure (PMA) and maximum allowable temperature (TMA) are PRESSURE SHELL DESIGN CONDITIONS, **NOT** OPERATING CONDITIONS.

** Valve No. is displayed for products with options. This item is omitted from the nameplate when there are no options.

Motive Medium Pressure Range	GP10L/GT10L	0.03 – 1.05 MPaG	0.3 – 10.5 barg	5 – 150 psig
	GP10M/GT10M	0.03 – 1.05 MPaG	0.3 – 10.5 barg	5 – 150 psig
	GP14M/GT14M	0.03 – 1.4 MPaG	0.3 – 14 barg	5 – 200 psig
	GP14M/GT14M (Cast Iron in Europe)	0.03 – 1.3 MPaG	0.3 – 13 barg	5 – 185 psig
Maximum Allowable Back Pressure	0.05 MPa/0.5 bar /7 psi less than motive medium pressure used			

Configuration

GP10L/GT10L

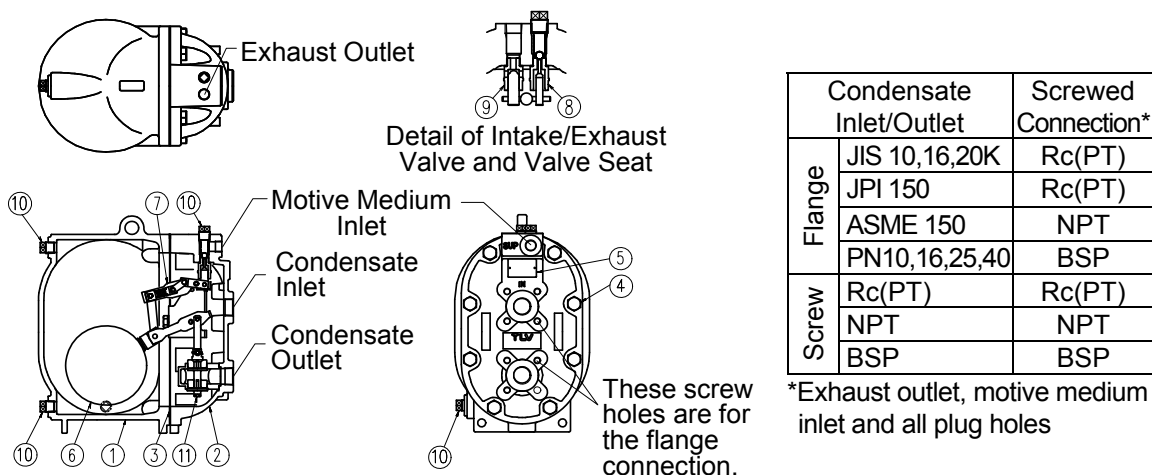

No.	Part Name	No.	Part Name	No.	Part Name
1	Body	5	Nameplate	9	Exhaust Valve Unit
2	Cover	6	Float	10	Plug
3	Cover Gasket	7	Snap-action Unit	11	Trap Unit (GT10L only)
4	Cover Bolt	8	Intake Valve Unit		

GP10M/GT10M

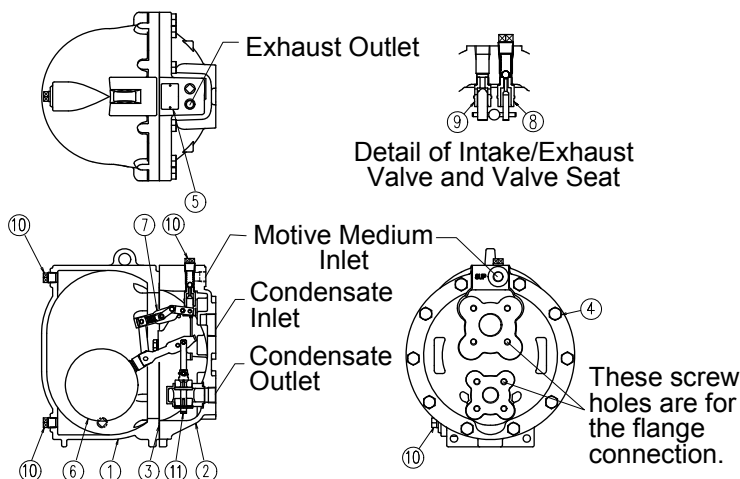

Condensate Inlet/Outlet		Screwed Connection*
Flange	JIS 10,16,20K	Rc(PT)
	JPI 150	Rc(PT)
	JPI 300	Rc(PT)
	ASME 150	NPT
	ASME 300	NPT
	PN10,16,25,40	BSP

*Exhaust outlet, motive medium inlet and all plug holes

GP14M/GT14M

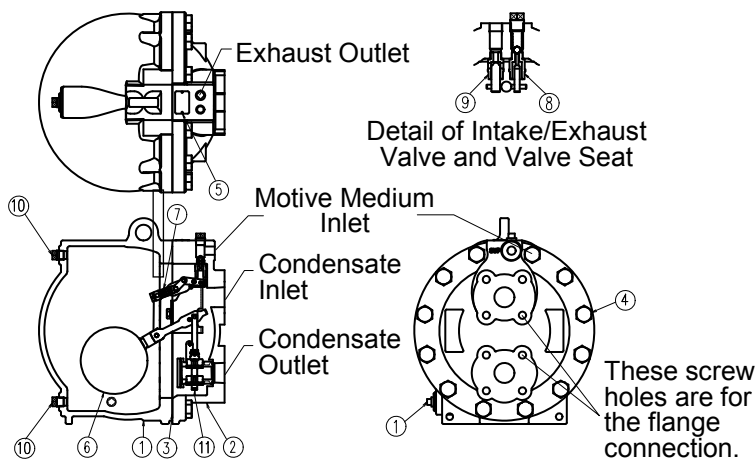

Condensate Inlet/Outlet		Screwed Connection*
Flange	JIS 10, 16, 20K	Rc(PT)
	JPI 150	Rc(PT)
	JPI 300	Rc(PT)
	ASME 150	NPT
	ASME 300	NPT
	PN10,16,25,40	BSP

*Exhaust outlet, motive medium inlet and all plug holes

No.	Part Name	No.	Part Name	No.	Part Name
1	Body	5	Nameplate	9	Exhaust Valve Unit
2	Cover	6	Float	10	Plug
3	Cover Gasket	7	Snap-action Unit	11	Trap Unit (GT10M/GT14M only)
4	Cover Bolt	8	Intake Valve Unit		

CKF5M

This check valve CKF5M is designed for use on **PowerTrap** only.

For the structure of check valves other than CKF5M, refer to the respective instruction manual.

CKF5M cannot be disassembled for maintenance.

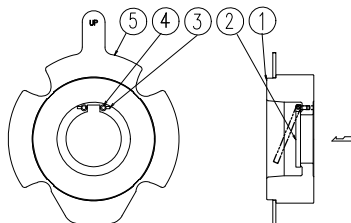

No.	Part Name
1	Body
2	Valve Disc
3	Hinge Pin
4	Holder Pin
5	Guide

Installation



Install properly and **DO NOT** use this product outside the recommended operating pressure, temperature and other specification ranges. Improper use may result in such hazards as damage to the product or malfunctions which may lead to serious accidents. Local regulations may restrict the use of this product to below the conditions quoted.



Use hoisting equipment for heavy objects (weighing approximately 20 kg (44 lb) or more). Failure to do so may result in back strain or other injury if the object should fall.



Take measures to prevent people from coming into direct contact with product outlets. Failure to do so may result in burns or other injury from the discharge of fluids.



Do not use excessive force when connecting threaded pipes to the product. Over-tightening may cause breakage leading to fluid discharge, which may cause burns or other injury.



Use only under conditions in which no water hammer will occur. The impact of water hammer may damage the product, leading to fluid discharge, which may cause burns or other injury.

Open System Piping (Steam System Example)

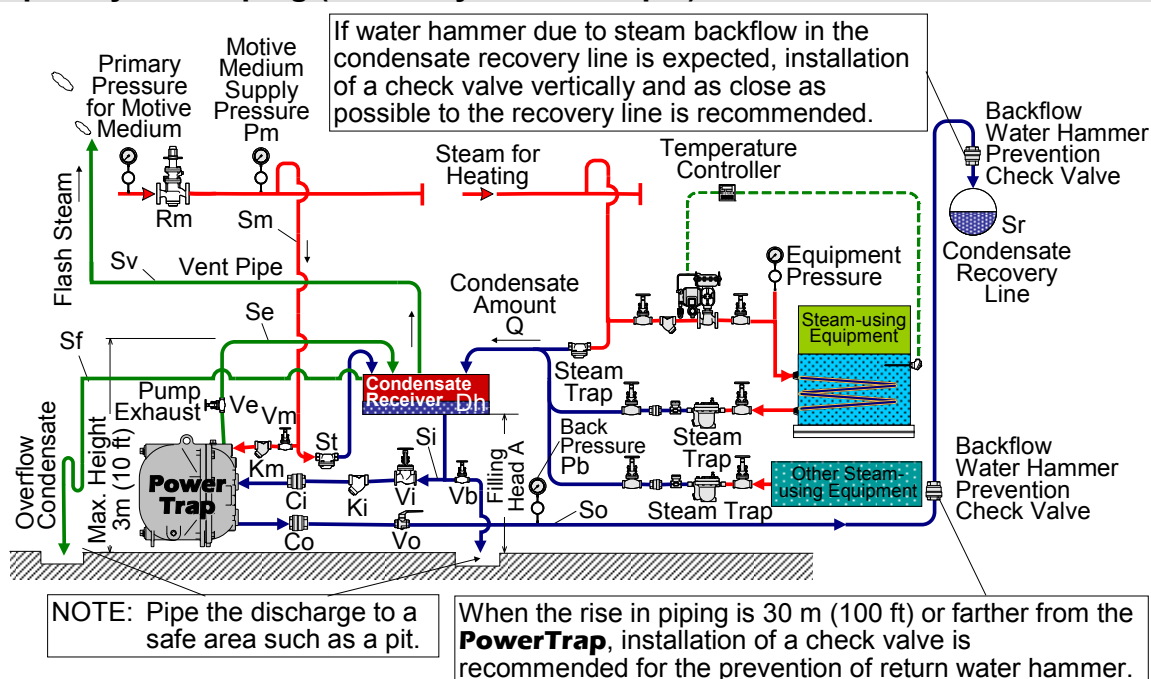

NOTE: This sketch is for explanation purposes only and is not intended as an installation design.

Necessity of installing a condensate receiver

It is necessary for storing condensate during pumping.

Condensate cannot enter the **PowerTrap** while condensate is being pumped.

Q	Condensate Amount	Se	Exhaust Pipe	Rm	Motive Medium Reducing Valve
A	Filling Head	Sv	Vent Pipe	St	Steam Trap on Drip Leg
Pm	Motive Medium Supply Pressure	Sf	Overflow Pipe	Vi	Valve on Condensate Inlet Pipe
Pb	Back Pressure	Dh	Condensate Receiver	Vo	Valve on Condensate Outlet Pipe
Si	Condensate Inlet Pipe	Ci	Condensate Inlet Check Valve	Vm	Valve on Motive Medium Supply Pipe
So	Condensate Outlet Pipe	Co	Condensate Outlet Check Valve	Ve	Valve on Exhaust Pipe
Sr	Condensate Recovery Line	Ki	Condensate Inlet Strainer	Vb	Bypass Valve
Sm	Motive Medium Supply Pipe	Km	Motive Medium Strainer		

Closed System Piping (Steam System Example)

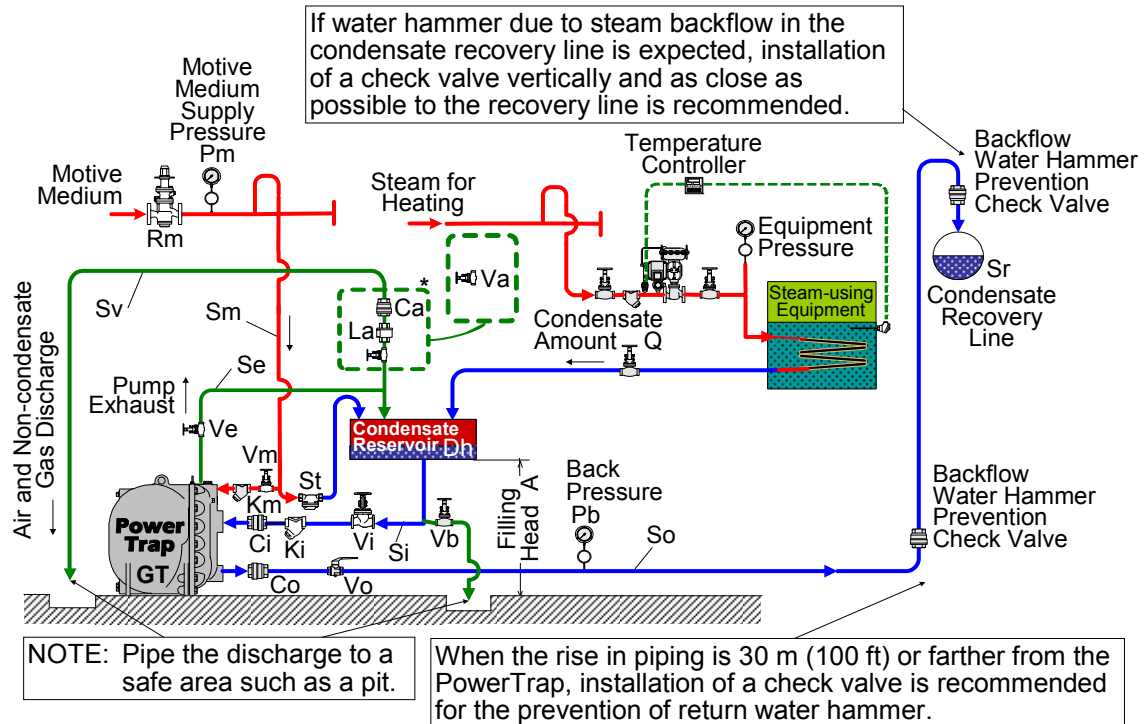

Q	Condensate Amount	Sv	Vent Pipe	Rm	Motive Medium Reducing Valve
A	Filling Head	Dh	Condensate Reservoir	St	Steam Trap on Drip Leg
Pm	Motive Medium Supply Pressure	GT	PowerTrap	Vi	Valve on Condensate Inlet Pipe
Pb	Back Pressure	Ci	Condensate Inlet Check Valve	Vo	Valve on Condensate Outlet Pipe
Si	Condensate Inlet Pipe	Co	Condensate Outlet Check Valve	Vm	Valve on Motive Medium Supply Pipe
So	Condensate Outlet Pipe	Ca	Check Valve for Air Vent	Ve	Valve on Exhaust Pipe
Sr	Condensate Recovery Line	La	Air Vent (for Steam)	Va	Valve for Air/Gas Discharge
Sm	Motive Medium Supply Pipe	Ki	Condensate Inlet Strainer	Vb	Bypass Valve
Se	Exhaust Pipe	Km	Motive Medium Strainer		

Installation Procedure

Refer to the systems outlined in the “General Description” section on page 5 to select the correct system and model (GT or GP) for the application. Installation, inspection, maintenance, repairs, disassembly, adjustment and valve opening/closing should be carried out only by trained maintenance personnel.

(1) Pumped Medium:

- Fluids that can be discharged through the **PowerTrap** are limited to steam condensate and water. **PowerTraps** that have been specially constructed for other specific fluids are not limited by this restriction.

(2) Motive Medium Supply Piping:

- The motive medium supply pipe diameter should be at least 15 mm ($1/2$ in).
- Install a 40-mesh or finer strainer on the **PowerTrap** motive medium supply pipe, as close to the **PowerTrap** as possible, while allowing sufficient space for maintenance of the strainer. Strainers should be angled in the 3 or 9 o'clock positions for horizontal installations.
- See “Specifications” on page 7 for the maximum motive medium inlet pressure.
- **For Open Systems:** Steam, compressed air or nitrogen may be used as the motive medium.
- **For Closed Systems:** Use steam as the motive medium. Except in special cases, do not use non-condensable gases such as air or nitrogen.
- When the motive medium is steam, if the application will require that the equipment be shut down (non-operating) for periods of 2 months or longer, install piping connecting the motive medium supply line to the receiver/reservoir pipe, being sure to install a drip leg on the motive medium supply line, and a steam trap in the drip leg (between where it branches to go to the **PowerTrap** and where it enters the receiver/reservoir pipe). (See item [St] in the drawings on pages 9 and 10.) This measure is not necessary when the motive medium is compressed air or nitrogen.

(3) Pressure Reducing Valve on the Motive Medium Supply Piping:

- When the supply pressure of the motive medium is greater than the maximum operating pressure of the **PowerTrap**, install a TLV **COSPECT** Series pressure reducing valve. Make sure that the motive medium pressure is lower than the maximum operating pressure of the **PowerTrap**. Use good piping practices when selecting the installation location for **COSPECT**.
In this case, be sure to install a safety valve between the pressure reducing valve and the **PowerTrap**.
- When the supply pressure of the motive medium is less than the maximum operating pressure of the **PowerTrap**, if a pressure reducing valve is to be installed to slow the speed of the flow, the installation of a safety valve is not required.
- Install the pressure reducing valve as far away from the **PowerTrap** as possible.
When the motive medium pressure is less than 0.5 MPaG (72.5 psig, 5 barg): at least 3 m (10 ft)
When the motive medium pressure is 0.5 MPaG or greater (72.5 psig or greater, 5 barg or greater): at least 3 m + 1 m / 0.1 MPaG (1 barg) over 0.5 MPaG (5 barg) (10 ft + 1 ft / 4.5 psig over 72.5 psig)
- The pressure setting on the pressure reducing valve should be between 0.05 and 0.15 MPa (7 – 20 psi, 0.5 – 1.5 bar) higher than the back pressure.
When the discharge capacity of the **PowerTrap** is insufficient for the set motive pressure, increase this set pressure even further.

(4) Exhaust Piping:

- The exhaust pipe diameter should be at least 15 mm (1/2 in).
- The exhaust pipe should be connected to the top of the receiver/reservoir.
- **For Open Systems:** If the GP exhaust line has to discharge to atmosphere, a sound level of approximately 90 dB may be emitted from the exhaust pipe discharge outlet for two to three seconds. If soundproofing measures are necessary, install a silencer. (If the exhaust line is connected to the condensate receiver, the sound level will be below 60 dB.)
- Make sure that the distance from the ground to the highest point on the exhaust pipe (where it enters the receiver/reservoir pipe) does not exceed 3 m (10 ft). If it exceeds 3 m (10 ft), condensate must be drained from the exhaust pipe in order not to obstruct the exhaust. Implement one of the following countermeasures: (See the figures below.)
 - (a) **For Open Systems only:** Add a float-type steam trap to the exhaust pipe at a point just above where the exhaust pipe exits the unit body. (Figure 1)
 - (b) **For Open and Closed Systems:** Add piping connecting the exhaust pipe to the condensate inlet pipe between the reservoir pipe and the strainer, being sure to install a check valve on the piping to prevent backflow of condensate from the condensate inlet pipe to the exhaust pipe. (Figure 2)

When the exhaust piping height exceeds 3 m (10 ft.)

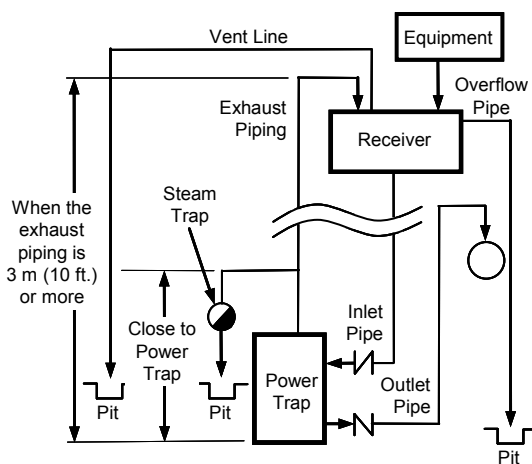

Figure 1: Open Systems

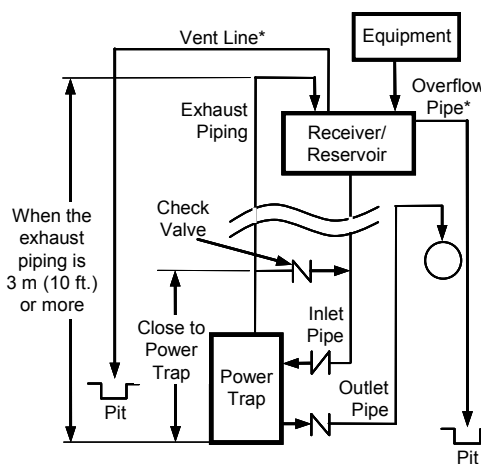
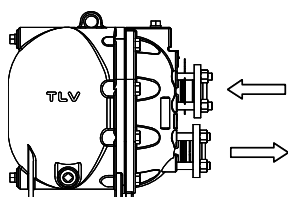

Figure 2: Open & Closed Systems
* For Open Systems only

(5) Inlet and Outlet Piping

- Install a 40-mesh or finer strainer on the **PowerTrap** pumped medium inlet pipe. The installation should be in a location that allows sufficient space for maintenance of the strainer.
- Ensure the inlet and outlet check valves are installed in the correct direction. The check valve on the inlet pipe in particular should be installed right next to the **PowerTrap**.



Make sure that the arrow on the check valve matches with the direction of flow.

- Stud bolt/nut, companion flange and gaskets, which are needed to connect a check valve are not included for the flanged model. Please prepare these by referring to the table below.

Stud bolt size for the flange connection

Model	Flange Standards	Connection and Nominal Size		Check Valve Type	Bolt Size
		mm	(in)		
GP10L GT10L	PN 10, 16, 25, 40	Inlet	25 (1)	CKF5M	M12 × 90 mm
		Outlet	25 (1)	CKF3M	
	ASME Class 125, 150	Inlet	25 (1)	CKF5M	1/2 in-13 UNC × 3 1/2 in
		Outlet	25 (1)	CKF3M	
	JIS 10, 16, 20K	Inlet	25 (1)	CKF5M	M16 × 90 mm
		Outlet	25 (1)	CKF3M	
GP10M GT10M	PN 10, 16, 25, 40	Inlet	40 (1 1/2)	CKF5M	M16 × 100 mm
		Outlet	25 (1)	CKF3M	M12 × 80 mm
	ASME Class 125, 150	Inlet	40 (1 1/2)	CKF5M	1/2 in-13 UNC × 4 in
		Outlet	25 (1)	CKF3M	1/2 in-13 UNC × 3 1/8 in
	ASME Class 250, 300	Inlet	40 (1 1/2)	CKF5M	3/4 in-10 UNC × 4 in
		Outlet	25 (1)	CKF3M	5/8 in-11 UNC × 3 1/8 in
	JIS 10, 16, 20K	Inlet	40 (1 1/2)	CKF5M	M16 × 100 mm
		Outlet	25 (1)	CKF3M	M16 × 80 mm
GP14M GT14M	PN 10, 16, 25, 40	Inlet	40 (1 1/2)	CKF5M	M16 × 100 mm
		Outlet	40 (1 1/2)	CKF3M	
	ASME Class 125, 150	Inlet	40 (1 1/2)	CKF5M	1/2 in-13 UNC × 4 in
		Outlet	40 (1 1/2)	CKF3M	
	ASME Class 250, 300	Inlet	40 (1 1/2)	CKF5M	3/4 in-10 UNC × 4 in
		Outlet	40 (1 1/2)	CKF3M	
	JIS 10, 16, 20K	Inlet	40 (1 1/2)	CKF5M	M16 × 100 mm
		Outlet	40 (1 1/2)	CKF3M	

- Only TLV check valves supplied with **PowerTrap** should be used; proper discharge capacity cannot be guaranteed with other check valves.
- Installation of check valve CKF5M (for flanged model):
CKF5M is a swing type check valve for the condensate inlet with a flange connection. The CKF5M must be installed in a correct orientation. Fit guide to stud bolts with “UP” mark pointing upwards.

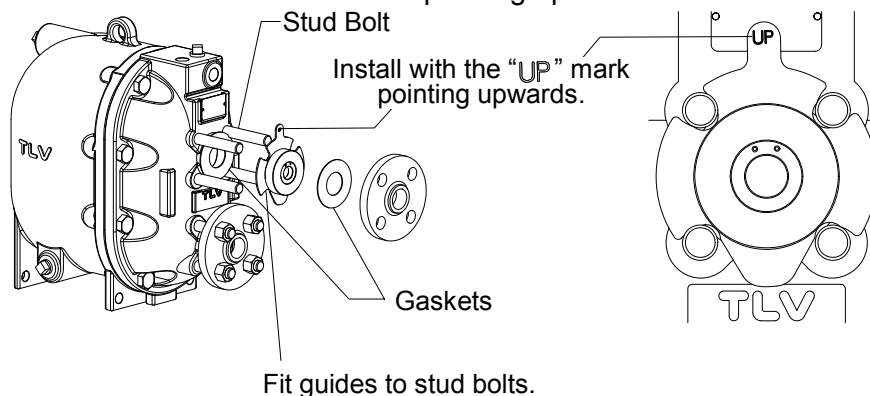

- Installation of check valve CKF3M (for flanged model):
CKF3M is a disc check valve for the condensate outlet with a flange connection. The CKF3M can be installed in any orientation. Install the check valve body by turning the positioning fin on the body, making sure that the center of the check valve matches the center of the flange (center of the

pipings). If the center of the check valve is off the center, the pumped medium inflow will be impaired, resulting in reducing the performance ability of the **PowerTrap**.

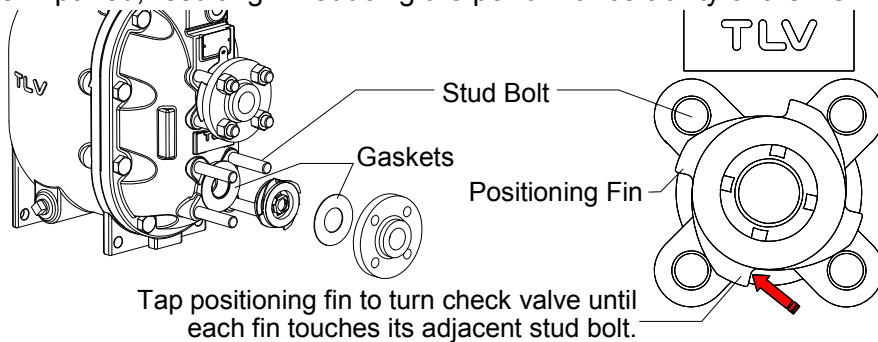

(6) Valves on the Various Pipes

- In order to ensure the proper discharge capacity, use full bore ball valves or gate valves on the pumped medium inlet and outlet lines as well as on the motive medium supply and exhaust lines.
If it is necessary to reduce the velocity of the motive medium supply, a needle valve can be used. However, be aware that the discharge capacity will be reduced. (Refer to “Operation” (1) e) on pages 21 and 22.)
- Install union or flanged joints between the valves and the **PowerTrap** to allow for easy maintenance.
- Be sure to provide the necessary maintenance space for **PowerTrap** disassembly and repair (see “Installation and Maintenance Space” on page 20).

(7) Receiver/Reservoir Pipe and Filling Head

- Please refer to “Sizing the Condensate Receiver/Reservoir” on pages 16 - 18.
The size and vent pipe aperture are determined by (a) the amount of flash steam in the in-flowing condensate (pumped medium) and (b) the amount of pumped medium held back while the **PowerTrap** is discharging.
If the receiver is small, the flow of flash steam may cause the condensate to flow out the vent pipe.
If the vent pipe size is small, the pressure in the receiver will rise, restricting the pumped medium inflow.
Be sure to select a receiver/reservoir pipe of the correct size.
- The filling head represents the distance from the bottom of the **PowerTrap** (from grade) to the bottom of the receiver/reservoir.
The standard filling head is 630 mm (25 in).
When an installation calls for a lower filling head, a filling head of less than 630 mm (25 in) is allowable. However, filling heads lower than the minimum filling heads listed below must not be used:

Inlet Check Valve Model	Minimum Filling Head
TLV CK3MG	GP/GT10L: 450 mm (18 in)
TLV CKF5M	GP/GT10L: 300 mm (12 in)
	GP/GT10M: 300 mm (12 in)
	GP/GT14M: 350 mm (14 in)

- **For Open Systems:**
 - If venting flash steam to a high area, an overflow pipe must be installed to discharge condensate to a safe area.
 - An overflow pipe should be installed at the side of the receiver.



- Be sure to install a vent pipe and an overflow pipe. Failure to install an overflow pipe is dangerous, as condensate may spurt from the vent pipe and could result in burns and other injuries.
- Pipe the vent pipe and the overflow pipe to a safe place such as a pit.
- Piping size of the overflow pipe should be the same or larger than condensate inlet pipe.

Examples of Overflow Piping for Open Systems

There is a possibility of condensed hot water dripping from vent pipe outlet. Make sure to extend to where people do not pass.

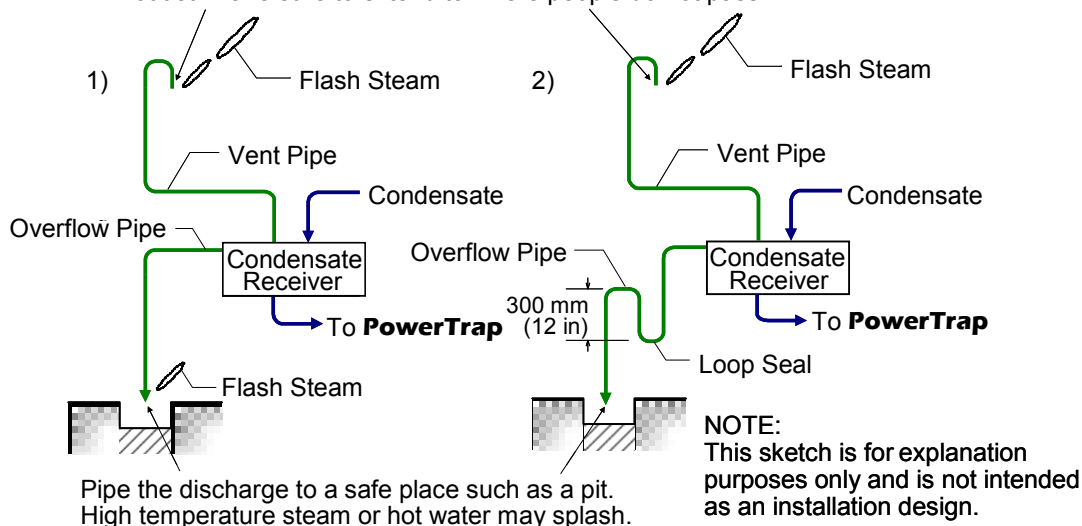

Explanations for overflow piping for open systems

1) If flash steam can be discharged from overflow pipe

Install overflow pipe and vent pipe separately.

2) If flash steam should not be released from overflow pipe (prevent flash steam release)

Install overflow pipe and vent pipe separately. For overflow pipe, install loop seal (approx. 300 mm (12 in)). Flash steam release from overflow pipe can be prevented since water always accumulates at loop seal. Piping size should be the same or larger than condensate inlet pipe.

- NOTE:
- There is a possibility of rust becoming clogged and/or corrosion since water always present in the loop seal; the possibility is greater if the piping diameter is too small (generally 25 mm (1 in) or smaller)
 - If the loop seal becomes clogged, hot overflow water will blow from vent pipe; make sure to install vent pipe to lead to a safe place
 - Do not install loop seal on the vent pipe

Contact TLV if neither 1) nor 2) above can be installed.

- **For Closed Systems:** An air vent for steam [La] is required to discharge the initial air in the steam-using equipment and the condensate reservoir pipe or any gas generated in the system. In this case, installing the check valve for air vent [Ca] will prevent air from being sucked in from the outlet of the vent pipe [Sv]. This check valve must be installed when the pressure inside the piping becomes negative. A valve for air discharge [Va] can be installed instead of the air vent (for steam) [La] and check valve for air vent [Ca].

When releasing the initial air using a valve for air discharge, leave the valve for air discharge [Va] slightly open until the **PowerTrap** has cycled 2 – 3 times. Close the valve for normal operation.

(8) Velocity at Outlet Piping

The **PowerTrap** uses the motive medium supply pressure to push out the condensate in the trap.

- Discharge capacity of pumped medium for each discharge operation:
 - GP10L/GT10L :approximately 6 liters (1.6 U.S. gal)
 - GP10M/GT10M :approximately 7.5 liters (2 U.S. gal)
 - GP14M/GT14M :approximately 12.5 liters (3.3 U.S. gal)
- The amount of time required for each discharge operation will be between 3 and 30 seconds, depending on the back pressure and the motive medium pressure. This means that the instantaneous flow through the pumped medium outlet pipe during the discharge operation is between 0.7 and 23 metric tonnes (180 and 6000 U.S. gal) per hour.
- When a condensate flowmeter is to be installed in the pumped medium outlet piping, it should be selected to reflect the intermittent operation and should be sized to accommodate the maximum and minimum instantaneous flow. For details, contact TLV.

Sizing the Condensate Receiver/Reservoir

When selecting the receiver/reservoir pipe for the **PowerTrap**, select from among the following 3 conditions:

(1) When large quantities of flash steam are involved

(For open systems using steam)

a) Determine the amount of flash steam:

$$\text{Amount of flash steam } F_s = Q \times (hd' - hh') / r$$

F_s : amount of flash steam (kg/h) (lb/h)

Q : amount of condensate (kg/h) (lb/h)

hd' : specific enthalpy (kJ/kg) (Btu/lb) of saturated condensate at condensate inlet set pressure (P_1)

hh' : specific enthalpy (kJ/kg) (Btu/lb) of saturated condensate at condensate receiver set pressure (P_2)

r : specific enthalpy (kJ/kg) (Btu/lb) vaporization (latent heat of steam) at condensate receiver set pressure (P_2)

- b) Determine the vent pipe diameter according to the amount of flash steam in Vented Receiver Table - 1 on the following page.
- c) Find the receiver diameter according to the amount of flash steam in Vented Receiver Table - 1 on the following page.
- d) Find the receiver diameter according to the amount of condensate in Vented Receiver Table - 2 on the following page.
- e) Determine the overflow pipe diameter (refer to the figure below).

NOTE: Overflow pipe diameter should be larger than the condensate inlet pipe diameter.

- f) Determine the condensate receiver diameter by selecting the largest value among those from c), d), and e).

Diameter for receiver must be more than 3× larger than the overflow pipe diameter.

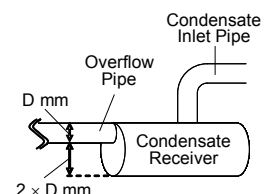
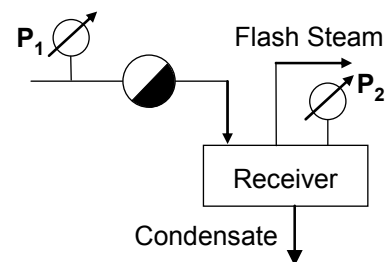

Vented Receiver Table - 1
(For atmospheric, open system installations, applicable trap – GP10L/GP10M/GP14M)

Flash Steam up to ~ kg/hour	Receiver Diameter mm (in) (Length: 1 m)	Vent Line Diameter mm (in)	Flash Steam up to ~ lb/hour	Receiver Diameter in (Length: 3.5 ft)	Vent Line Diameter in
25	80 (3)	25 (1)	50	3	1
50	100 (4)	50 (2)	75	4	1½
75	125 (5)	50 (2)	100	4	2
100	150 (6)	80 (3)	200	6	2½
150	200 (8)	80 (3)	300	8	3
200	200 (8)	100 (4)	400	8	4
300	250 (10)	125 (5)	600	10	4
400	300 (12)	125 (5)	800	12	6
500	350 (14)	150 (6)	1000	14	6
700	400 (16)	200 (8)	1400	16	8
800	450 (18)	200 (8)	1600	18	8
1000	500 (20)	200 (8)	2000	20	8
1100	500 (20)	250 (10)	2200	20	10
1400	550 (22)	250 (10)	2800	22	10
1500	600 (24)	250 (10)	3000	24	10

Vented Receiver Table - 2
(For atmospheric, open system installations, applicable trap – GP10L/GP10M/GP14M)

Amount of Condensate kg/hour	Receiver Diameter mm (in) (Length: 1 m)	Amount of Condensate lb/hour	Receiver Diameter in (Length: 3.5 ft)
1000 or less	80 (3)	2200 or less	3
1500	100 (4)	3300	4
2000	125 (5)	4400	5
3000	150 (6)	6600	6
6000	200 (8)	13000	8
10000	250 (10)	22000	10

NOTE: When amount of flash steam and condensate are between two values in the table, select the larger value (one line below).

- (2) When flash steam is not involved
(For closed systems)

Refer to the following table to determine the reservoir pipe diameter and length based on the amount of condensate:

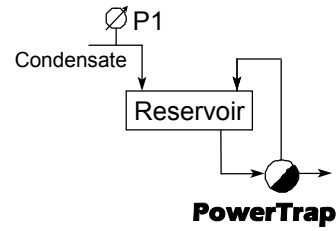

Reservoir Pipe Table
(For equalized, closed system installations)

Amount of Pumped Medium (kg/h)	Reservoir Diameter (mm) & Length (m)							Amount of Pumped Medium (lb/h)	Reservoir Diameter (in) & Length (ft)						
	40	50	80	100	150	200	250		1 1/2	2	3	4	6	8	10
300 or less	1.2m	0.7						500 or less	3.0 ft	2.0					
400	1.5	1.0						700	4.0	2.5	1.0				
500	2.0	1.2	0.5					1000	5.5	3.5	1.5				
600		1.5	0.6					1200		4.5	2.0	1.0			
800		2.0	0.8	0.5				1500			2.5	1.5			
1000			1.0	0.7				2000			3.5	2.0			
1500			1.5	1.0				3000			4.5	3.0			
2000			2.0	1.3	0.6			4000			6.5	4.0	1.5		
3000				2.0	0.9	0.5		5000				5.0	2.5		
4000					1.2	0.7		6000				5.5	2.5	1.5	
5000					1.4	0.8	0.5	7000				6.5	3.0	1.5	
6000					1.7	1.0	0.6	8000					3.5	2.0	
7000					2.0	1.2	0.7	9000					4.0	2.5	1.5
8000						1.3	0.8	10000					4.5	2.5	1.5
9000						1.5	0.9	12000					5.0	3.0	2.0
10000						1.7	1.0	14000					6.0	3.5	2.5
								16000					6.5	4.0	2.5
								18000						4.5	3.0
								20000						1.5	1.5

NOTE: Reservoir length can be reduced by 50% when the motive pressure (P_m) divided by the back pressure (P_b) is "2" or greater. (When P_m ÷ P_b ≥ 2)

- (3) When there are small quantities of flash steam and a large amount of condensate (E.g., open systems pumping large amounts of super-cooled condensate)
Consult the sizing tables in sections (1) and (2).
- Select the condensate receiver size based on the larger of (1) and (2).
 - Select the vent pipe diameter and overflow pipe diameter from (1).

Installing Several PowerTrap Units in Parallel

Refer to the figure below as a general guide for the piping when several **PowerTrap** units are to be installed after the same pumped medium inlet pipe.

The size of the pumped medium inlet pipe, return line and exhaust pipe manifold is determined by the number of **PowerTrap** units installed.

When specifications exist separately from the instruction manual, follow the specifications.

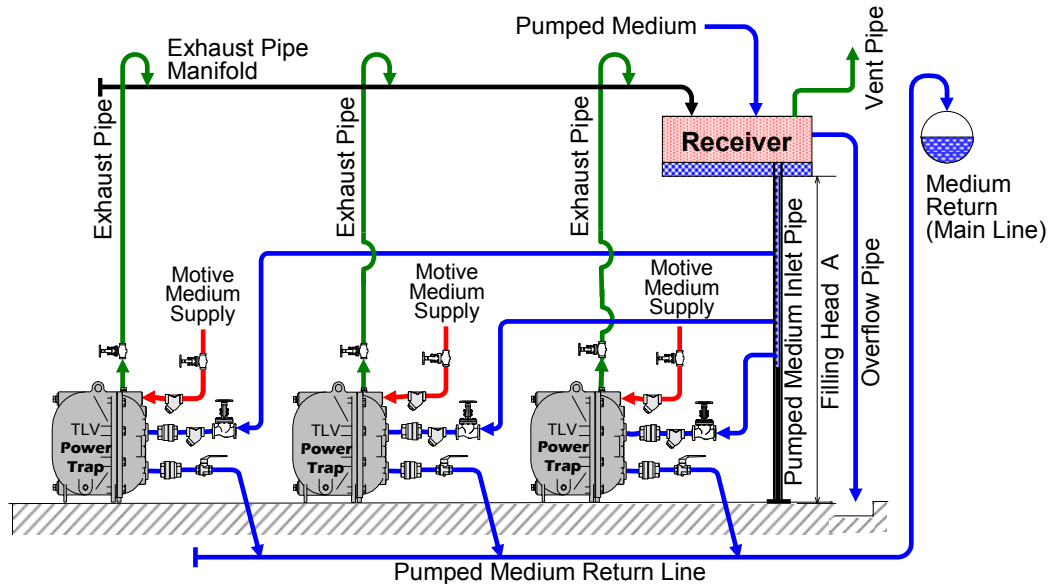

NOTE: This sketch is for explanation purposes only and is not intended as an installation design.

Number of PowerTrap Units Installed	Pumped Medium Inlet Pipe Size	Pumped Medium Return Line Size		Exhaust Pipe Manifold Size	Overflow Pipe Size	Vent Pipe Size
All Models	All Models	GP/GT10L GP/GT10M	GP14M GT14M	All Models	All Models	All Models
2	40 mm (1½ in)	32 mm (1¼ in)	50 mm (2 in)	25 mm (1 in)	Determine overflow pipe size according to "Sizing the Condensate Receiver/ Reservoir" on page 16	See the Vent Line Diameter column in Table-1 on page 17
3	50 mm (2 in)	32 mm (1¼ in)	50 mm (2 in)	32 mm (1¼ in)		
4	65 mm (2½ in)	32 mm (1¼ in)	50 mm (2 in)	32 mm (1¼ in)		
5	65 mm (2½ in)	40 mm (1½ in)	65 mm (2½ in)	40 mm (1½ in)		
6	80 mm (3 in)	40 mm (1½ in)	65 mm (2½ in)	40 mm (1½ in)		

Installation and Maintenance Space

Anchoring the Body

Mount Position for Anchor Bolts

Model	GP10L/GT10L GP10M/GT10M		GP14M/GT14M	
A	220	(8 ¹¹ / ₁₆)	316	(12 ¹ / ₂)
B	220	(8 ¹¹ / ₁₆)	316	(12 ¹ / ₂)
C	185	(7 ⁵ / ₁₆)	217	(8 ⁹ / ₁₆)
D	100	(3 ¹⁵ / ₁₆)	102	(4)

(Unit: mm (in))

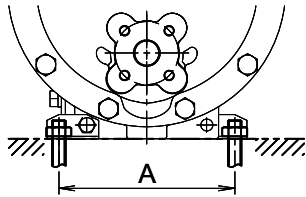

Mount position for Anchor Bolts

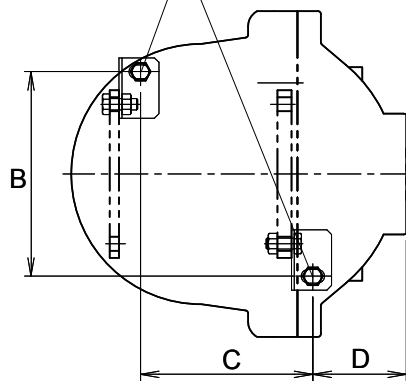

Detail Drawing for Anchor Fixture Set

(Unit: mm (in))

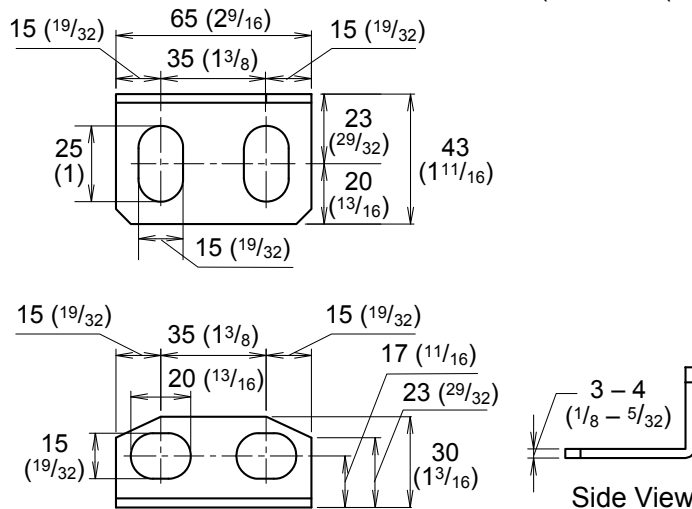

Anchor Fixture Set included in the package. Fixture is designed so that the body can be moved backwards (opposite direction to the cover). Failure to use fixtures or use of other than those provided may prevent mobility of the body, and inhibit maintenance. (Consisting of two anchor brackets and two hex bolts with nuts)
 (Suitable Anchor Bolts and nuts (Size M12) to be supplied by the customer)
 (Bolt Holes in Product Body: $\varnothing 15$ mm (⁹/₁₆ in))

- Anchor fixture set:
- Anchor fixture × 2
- Hex bolt (M12) × 2
- Hex nut (M12) × 2
- Washer (Diameter: 12) × 2

Maintenance Space

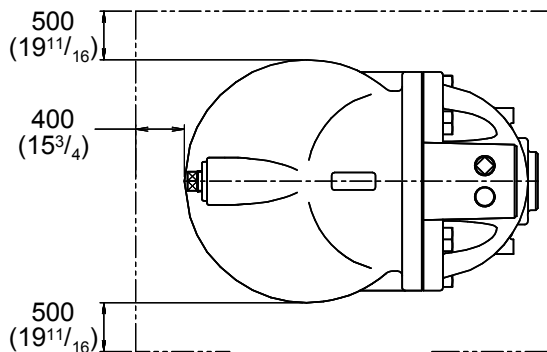

Maintenance Space

The maintenance space shown in the figure below should be provided to enable inspection and disassembly/repair of the **PowerTrap**. Maintenance may not be performed if there is not enough space for disassembly/reassembly.

Unit: mm (in)

Operation and Periodic Inspection

WARNING

- After all piping work has been completed in accordance with the specific piping system designed when the decision to utilize the PowerTrap was made, check once again to make sure that all pipe connections have been tightened, gaskets have been inserted where needed and all parts are securely installed.
- When beginning operation, make sure that the operator stays well clear of the release area of the vent line and overflow piping. At the start-up of operation, large quantities of condensate may flow, causing the PowerTrap to momentarily overload. If this occurs in open systems, hot condensate may spurt from the vent piping or overflow piping and could result in burns, other injuries or damage to equipment.

CAUTION

Install properly and DO NOT use this product outside the recommended operating pressure, temperature and other specification ranges. Improper use may result in such hazards as damage to the product or malfunctions which may lead to serious accidents. Local regulations may restrict the use of this product to below the conditions quoted.

CAUTION

When disassembling or removing the product, wait until the internal pressure equals atmospheric pressure and the surface of the product has cooled to room temperature. Disassembling or removing the product when it is hot or under pressure may lead to discharge of fluids, causing burns, other injuries or damage.

CAUTION

Be sure to use only the recommended components when repairing the product, and NEVER attempt to modify the product in any way. Failure to observe these precautions may result in damage to the product or burns or other injury due to malfunction or the discharge of fluids.

Installation, inspection, maintenance, repairs, disassembly, adjustment and valve opening/closing should be carried out only by trained maintenance personnel.

Operation

(1) Valve Operation

Refer to the drawings in “Installation” on pages 9 and 10 to become familiar with the symbols used for the various valves.

If water hammer has occurred, immediately cease operation and close any valves that are operating.

- Slowly open the valve [Ve] on the exhaust pipe.
- Slowly open the valve [Vm] on the motive medium supply pipe.
Make sure that there is no sound of flow from the exhaust pipe [Se] or the condensate inlet pipe [Si].
- Slowly open the valve [Vo] on the pumped medium outlet pipe.
- Slowly open the valve [Vi] on the pumped medium inlet pipe.
When using a valve for air/gas discharge [Va] for venting air on a closed system, leave the valve [Va] slightly open until the **PowerTrap** has cycled 2 or 3 times in order to release any air inside the system, then close the valve [Va].
- The **PowerTrap** is normal if it operates intermittently; first exhausting the motive medium to fill with pumped medium, then taking in motive medium to force the condensate out.
 - The interval of operation will vary greatly depending on the amount of pumped medium inflow, the temperature, the motive medium (steam or gas) and the motive pressure. (The interval of operation is considered to be the length of time between the start of one discharge cycle and the start of the next discharge cycle.)

The interval of operation T_c (s) can be roughly determined using the following formula:

$$\begin{array}{ll} T_c = 21,600/Q \text{ (GP/GT10L)} & T_c = 47,600/Q_p \text{ (GP/GT10L)} \\ T_c = 27,000/Q \text{ (GP/GT10M)} & T_c = 59,500/Q_p \text{ (GP/GT10M)} \\ T_c = 45,000/Q \text{ (GP/GT14M)} & T_c = 99,200/Q_p \text{ (GP/GT14M)} \end{array}$$

Q: amount of condensate (inflowing pumped medium) (kg/h)

Q_p : amount of condensate (inflowing pumped medium) (lb/h)

- The GP10L/GT10L can discharge approximately 6 liters (1.6 U.S. gal) of pumped medium, 7.5 liters (2 U.S. gal) for GP10M/GT10M and 12.5 liters (3.3 U.S. gal) for GP14M/GT14M for each discharge operation.

The amount of time required for each discharge operation will be between 3 and 30 seconds, depending on the back pressure and the motive medium pressure.

- (2) If an error such as a leak or water hammer occurs after beginning **PowerTrap** operation, shut off the valves immediately in the following order:
valve [Vm] on motive medium supply pipe → pumped medium inlet valve [Vi] → pumped medium outlet valve [Vo] → valve [Ve] on exhaust pipe.
- (3) Whenever any type of malfunction is suspected in the **PowerTrap**, refer to the “Troubleshooting” section on pages 32 – 36.

Periodic Inspection and Diagnosis

There are two types of periodic inspection: the visual inspection and the disassembly inspection.

(1) Visual Inspection

- As a general rule, this inspection should be performed at least once every 3 months.
- Check the following items:
 - a) There should be no leakage from the **PowerTrap** or from any of the connections.
 - b) The **PowerTrap** unit should be operating cyclically (one indication being the sharp, mechanical sound of the snap-unit operating at the transition between the filling and the discharge parts of the cycle). Immediately after the end of the discharge part of the cycle and during the filling part of the cycle, the sound of flow in the exhaust pipe should be heard. During the pumping (discharge) part of the cycle, flow in the motive medium supply pipe should be heard.
 - c) Pumped medium should not accumulate in the (steam-using) equipment, and the temperature of the equipment should not be abnormally low.
 - d) For open systems, verify that an overflow pipe from the receiver is installed.
 - e) For open systems, no steam should be seen flowing out through the vent pipe.
 - f) There should not be any abnormal noise from the pumped medium outlet pipe or the pumped medium recovery line when the **PowerTrap** operates.

(2) Disassembly Inspection

- Refer to the “Disassembly/Reassembly” section on pages 24 – 31.
- As a general rule, this inspection should be performed at least once every 2 years.
- When inspecting the interior of the unit, check the following items:
 - a) Make sure the snap-action moves up and down smoothly as the float rises and falls.
 - b) In the case of the GT model, make sure the valve in the trap unit moves up and down smoothly as it opens and closes.
 - c) Make sure the valve shafts in the intake (motive medium) and exhaust valves move up and down smoothly.
 - d) Make sure the float is not damaged and has not filled with water.
 - e) Make sure all nuts and bolts are properly installed and fastened.
 - f) Check to make sure that there is no foreign matter sticking to the shafts and levers of any of the units, and make sure there is no abnormal wear.
- When reassembling, be sure to replace the body and cover gaskets with new gaskets.
- Also replace any parts that are broken or show serious wear.
- If any parts require replacement, refer to “Replacement Parts” on page 25.

Disassembly/Reassembly



WARNING

NEVER apply direct heat to the float. The float may explode due to increased internal pressure, causing accidents leading to serious injury or damage to property and equipment.



CAUTION

Use hoisting equipment for heavy objects (weighing approximately 20 kg (44 lb) or more). Failure to do so may result in back strain or other injury if the object should fall.



CAUTION

When disassembling or removing the product, wait until the internal pressure equals atmospheric pressure and the surface of the product has cooled to room temperature. Disassembling or removing the product when it is hot or under pressure may lead to discharge of fluids, causing burns, other injuries or damage.



CAUTION

Do not use excessive force when connecting threaded pipes to the product. Over-tightening may cause breakage leading to fluid discharge, which may cause burns or other injury.

Use the procedures on the following pages to remove components. Use the same procedures in reverse to reassemble.

(Installation, inspection, maintenance, repairs, disassembly, adjustment and valve opening/closing should be carried out only by trained maintenance personnel.)

In cases where sufficient maintenance space has been provided for (see page 20, "Installation and Maintenance Space"), maintenance can be carried out without disconnecting the inlet and outlet piping. Where there is insufficient maintenance space, first disconnect the inlet and outlet piping, and then move the unit to a spacious area in which maintenance can be carried out safely.

When reassembling:

- Be sure to replace the body and cover gaskets with new gaskets. Also replace any parts that are broken or show serious wear. If any parts require replacement, refer to "Replacement Parts" on page 25.
- When reassembling, coat threads and bolts with anti-seize. Tighten the body and cover bolts in a uniform manner left and right, being careful to avoid uneven tightening.
- If drawings or other special documentation were supplied for the product, any torque given there takes precedence over values shown here.

Replacement Parts

The following replacement parts kits are available from TLV. Parts are not available individually, only together in kits. (Unit: mm)

<p>1. Cover Gasket GP10L/GT10L GP10M/GT10M/ GP14M/GT14M</p> <p>D: GP/GT10M: $\varnothing 300$ GP/GT14M: $\varnothing 345$</p>	<p>2. Float</p> <p>L: GP/GT10M and GP/GT10L :191 GP/GT14M:196</p> <p>Split Pin (x2)</p>
<p>3. Snap-action Unit</p> <p>Split Pin (x2) Hex Bolt (x2) Spring Washer (x2)</p>	<p>4. Motive Medium Intake Valve Unit</p> <p>NOTE: Parts used for GP/GT14M is not compatible to other models.</p>
<p>5. Exhaust Valve Unit</p> <p>NOTE: Parts used for GP/GT14M is not compatible to other models.</p>	<p>6. Trap Unit for GT10L/GT10M</p> <p>Hex Bolt (x2) Spring Washer (x2)</p> <p>NOTE: Parts used for GP/GT14M is not compatible to other models.</p>

Recommended Tools List for Disassembly/Reassembly

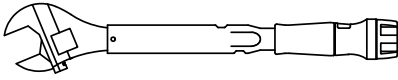
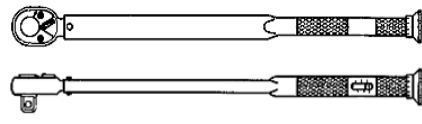
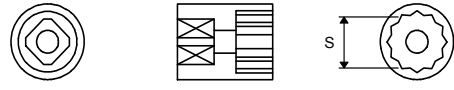
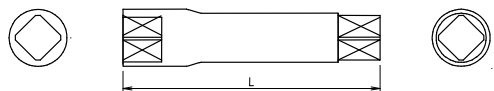
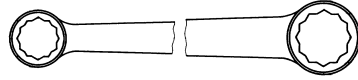
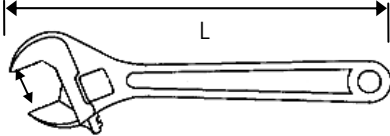
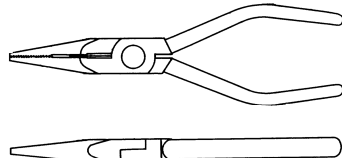
No.	Tool Name	Step Used		Tool
		GP	GT	
1	Torque Wrench (Adjustable Type) 30 N·m (22 lbf·ft)	1 7	1 7	
2	Torque Wrench (Ratchet) 60 – 200 N·m (44 – 150 lbf·ft)	1 5 7	1 4 5 7	
3	Sockets Distance across flats = S 19 mm ($\frac{3}{4}$ in) 22 mm ($\frac{7}{8}$ in) 24 mm ($\frac{15}{16}$ in) 30 mm ($1\frac{3}{16}$ in)	5 7 1 1	4, 5 7 1 1	
4	Extension Bar L = 150 mm ($5\frac{7}{8}$ in)	7	4, 7	
5	Offset Wrench 19 mm ($\frac{3}{4}$ in) 22 mm ($\frac{7}{8}$ in) 24 mm ($\frac{15}{16}$ in)	5 7 1	4, 5 7 1	
6	Adjustable Wrench L = 300 mm (12 in)	1 7	1 7	
7	Needle-Nose Pliers	2	2 3	

(1 N·m \approx 10 kg·cm)

NOTE: If drawings or other special documentation were supplied for the product, any torque given there takes precedence over values shown here.

Disassembly and reassembly are explained here by taking the screwed connection GT10L as an example.

1. Removing/Reattaching the Body from/to the Cover

Prepare a new, replacement cover gasket before beginning this step.

Part	Disassembly	Reassembly								
Drain Plug	<ul style="list-style-type: none"> Discharging condensate is carried out with intake (motive medium), exhaust, inlet and outlet piping still connected to the unit. Using a 300 mm (12 in) long adjustable wrench, slowly loosen plug to release pressure and discharge fluid; take care to avoid being burned by fluid discharge. 	<ul style="list-style-type: none"> Wrap threads with 3 – 3.5 turns of sealing tape or apply sealing compound. Tighten to a torque of 30 N·m (22 lbf·ft). 								
Cover Bolts M16: 8 pcs (GP/GT10L) M16: 10 pcs (GP/GT10M) M20: 12 pcs (GP/GT14M)	<ul style="list-style-type: none"> Using a socket wrench for the appropriate distance across flats shown below, loosen each bolt slowly one turn in an alternating diagonal pattern: <table border="1" style="margin-left: 20px;"> <tr> <td>GP/GT10L, GP/GT10M</td> <td>GP/GT14M</td> </tr> <tr> <td>24 mm (15/16 in)</td> <td>30 mm (1 3/16 in)</td> </tr> </table> <ul style="list-style-type: none"> Once all bolts have been loosened, verify that there is no internal pressure before completely removing the bolts. 	GP/GT10L, GP/GT10M	GP/GT14M	24 mm (15/16 in)	30 mm (1 3/16 in)	<ul style="list-style-type: none"> Reverse steps in disassembly. Refer to the table below and tighten to the proper torque: <table border="1" style="margin-left: 20px;"> <tr> <td>GP/GT10L, GP/GT10M</td> </tr> <tr> <td>110 N·m (81 lbf·ft)</td> </tr> <tr> <td>GP/GT14M</td> </tr> <tr> <td>200 N·m (150 lbf·ft)</td> </tr> </table>	GP/GT10L, GP/GT10M	110 N·m (81 lbf·ft)	GP/GT14M	200 N·m (150 lbf·ft)
GP/GT10L, GP/GT10M	GP/GT14M									
24 mm (15/16 in)	30 mm (1 3/16 in)									
GP/GT10L, GP/GT10M										
110 N·m (81 lbf·ft)										
GP/GT14M										
200 N·m (150 lbf·ft)										
Anchors	<ul style="list-style-type: none"> Remove the bolts that hold the anchor brackets to the body and rotate the anchor brackets on their base bolts so that they will not interfere with removal of the body from the cover. 	<ul style="list-style-type: none"> Reverse steps in disassembly. 								
Body / Cover	<ul style="list-style-type: none"> Make sure to secure sufficient space around the body to allow it to be pulled straight off. As the body weighs approximately 28 kg (62 lb) (GP/GT10L), 31 kg (68 lb) (GP/GT10M) or 85 kg (187 lb) (GP/GT14M), use a block and tackle hoist to assist in its removal. When moving the body away from and clear of the cover, lift the body only about 1 cm (3/8 in), to avoid contact with the float and other internal parts. In addition, to avoid contact with the float when removing the body, lift the float and the float lever slightly. Do not tilt the body more than 15° in any plane. 	<ul style="list-style-type: none"> Reverse steps in disassembly while referring to the figure below. 								
Cover Gasket	<ul style="list-style-type: none"> The gasket will be destroyed upon disassembly, adhering to both body and cover; using a scratch-free scraper, carefully scrape the gasket from both body and cover surfaces. 	<ul style="list-style-type: none"> Check that all pieces of old gasket have been removed, then install a new gasket. 								

(1 N·m ≈ 10 kg·cm)

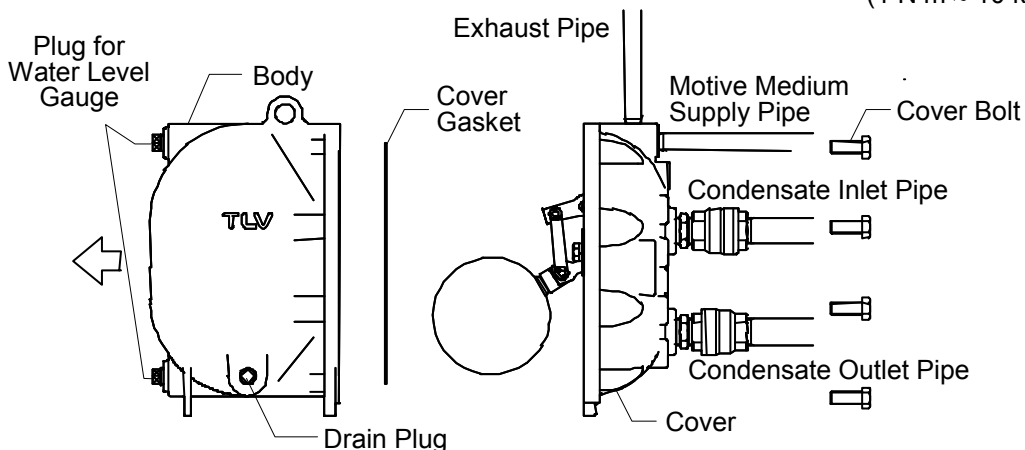

GP10L shown. GT10L configuration differs slightly

2. Removing/Reattaching the Float

It is not necessary to remove the float if only the intake (motive medium) and exhaust valves are to be serviced or replaced. It is not always necessary to replace the float when replacing the snap-action unit. The float should be replaced only when there are irregularities such as damage to its exterior or condensate found inside the float.

Part	Disassembly	Reassembly
Split Pin	<ul style="list-style-type: none"> Using needle-nose pliers, remove one split pin. 	<ul style="list-style-type: none"> Compare to diagram to make sure all parts have been replaced and are in the proper order. It is very important that washers and spacers are in the correct order, in order to prevent loosening of the float due to vibration during operation. Replace with a new stainless steel split pin, being sure to bend ends to secure in place.
Float Pin / Washers / Spacers / Float	<ul style="list-style-type: none"> Remove the float pin, holding one hand underneath to catch washers and spacers; be very careful not to allow the float to fall. 	<ul style="list-style-type: none"> Place one washer on the float pin, then insert partially into the hole on one connecting arm. Being very careful that parts are in the proper order and holes are aligned, reassemble all parts, including the float.

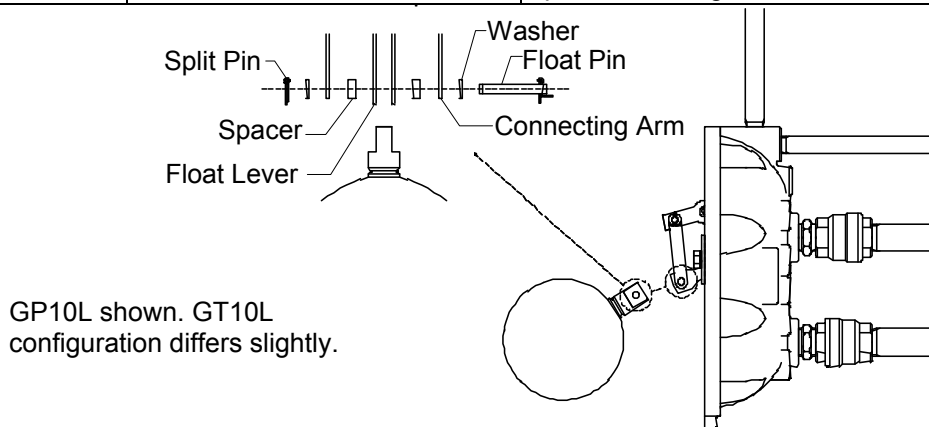

3. Separating/Rejoining the Trap Rod and Trap Unit (GT10L/GT10M/GT14M only)

Part	Disassembly	Reassembly
Split Pins/ Washers/ Connecting Pin	<ul style="list-style-type: none"> Pull the end of the lever arm up until the snap-action units snaps over, making the connecting pin accessible. Using needle-nose pliers, open one split pin and remove it and its washer from the connecting pin. Remove the connecting pin, being careful to keep it and the washers in a safe place for reassembly. 	<ul style="list-style-type: none"> Make certain that the lever arm has been raised. Align the trap rod to the trap connector, and then align the pin holes. Place one washer on the connecting pin, and reinsert into the pin holes. Place the second washer on the opposite end of the connecting pin, and insert a new stainless steel split pin. Bend the ends of the split pin with needle-nose pliers to secure in place.

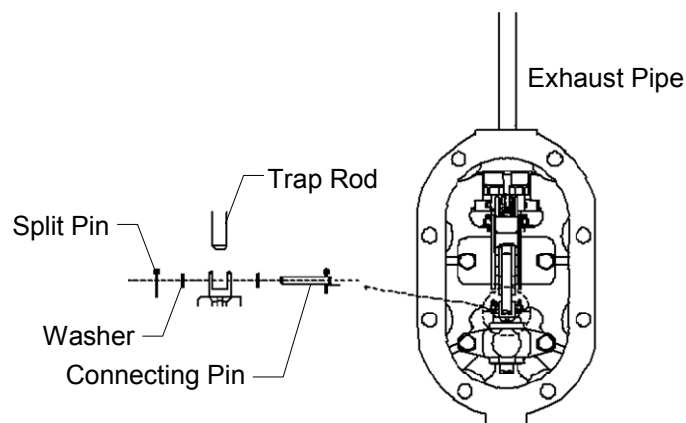

4. Removing/Reattaching the Trap Unit (GT10L/GT10M/GT14M only)

It is not necessary to remove the trap unit when only the intake (motive medium) and exhaust valves or the snap-action unit is to be serviced or replaced. It is possible to remove the snap-action unit without removing the trap unit (see step 5). Remove the connecting pin (step 3) before proceeding.

Part	Disassembly	Reassembly
Bolts/ Spring Washers	<ul style="list-style-type: none"> Using a 19 mm ($\frac{3}{4}$ in) socket wrench with an extension bar, loosen the bolts holding the trap unit to the cover. 	<ul style="list-style-type: none"> Coat the bolt threads (trap unit bolts are longer than snap-action unit bolts) with anti-seize. Insert bolts and washers, then finger tighten. Tighten to a torque of 60 N·m (44 lbf·ft)
Trap Unit	<ul style="list-style-type: none"> Finish removing the bolts by hand, then remove the trap unit being careful not to let the trap valve drop out. 	<ul style="list-style-type: none"> Align the boss inside the discharge port in the cover, as shown below. Be sure to reinsert the spring washers.
Gasket	<ul style="list-style-type: none"> The gasket should remain on the trap unit. If the gasket adheres to the cover, gently remove it. 	<ul style="list-style-type: none"> If the gasket remained on the trap unit, check for damage and reuse if no damage is found; if it adhered to the cover (came out of its groove), replace with a new gasket.

(1 N·m \approx 10 kg·cm)

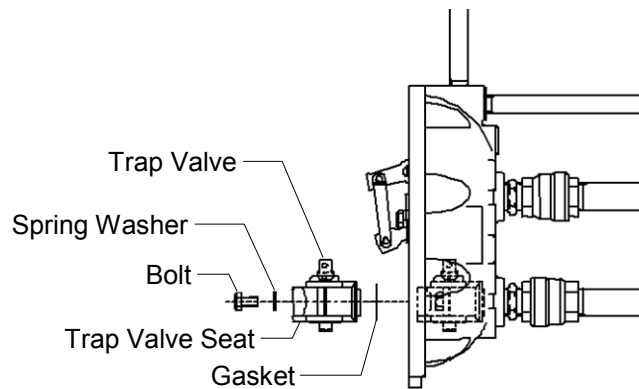

5. Removing/Reattaching the Snap-action Unit

It is not necessary to remove the float before removing the snap-action unit.

Part	Disassembly	Reassembly
Lever Arm	<ul style="list-style-type: none"> Pull the end of the lever arm down until the snap-action unit snaps over and the float end of the lever arm is at its lowest position. 	<ul style="list-style-type: none"> See disassembly.
Bolts	<ul style="list-style-type: none"> Using a 19 mm ($\frac{3}{4}$ in) socket wrench, loosen the four bolts that hold the snap-action and lever units to the cover. 	<ul style="list-style-type: none"> Coat bolt threads with anti-seize. Be sure to reinsert spring washers. Assemble the bolts and spring washers, then finger-tighten. Tighten to a torque of 60 N·m (44 lbf·ft)
Snap-Action Unit	<ul style="list-style-type: none"> Support the snap-action and lever units with one hand while removing the loosened bolts from the cover with the other. Be careful not to let any parts fall, including washers and baffle plate. Do not tip the snap-action unit, as intake (motive medium) and exhaust valves may fall off. When working with the snap-action unit, take care not to pinch fingers, etc. 	<ul style="list-style-type: none"> Reinsert the snap-action unit very carefully, inserting tips of intake and exhaust valves into the bottom of their respective valve seats, then continuing to insert all the way up into the valve seats as you reattach the snap-action unit. Align the snap-action unit bolt holes to the bolt holes in the cover.

(1 N·m \approx 10 kg·cm)

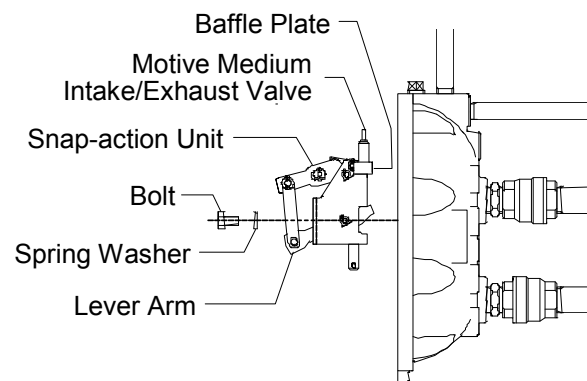

6. Removing/Reinstalling the Motive Medium Intake and Exhaust Valves

Part/Step	Disassembly	Reassembly
Motive Medium Intake Valve/Exhaust Valve	<ul style="list-style-type: none"> Remove each valve by sliding it sideways away from the center until it comes free of its pin. 	<ul style="list-style-type: none"> Align each valve with its pin, and slide it to the center. Make sure that the pointed intake (motive medium) valve is on the left side, and the rounded exhaust valve is on the right.

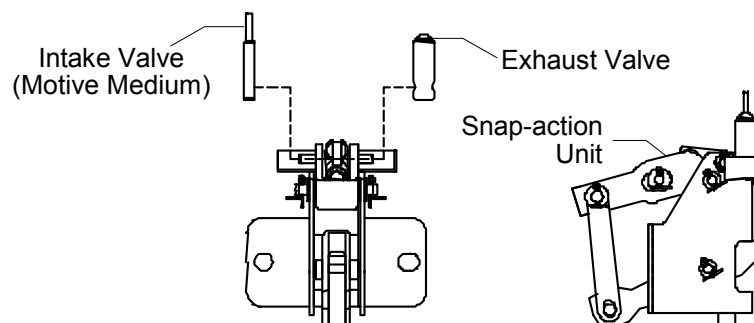

7. Removing/Reinstalling the Motive Medium Intake and Exhaust Valve Seats

Part/Step	Disassembly	Reassembly
Motive Medium Intake: Valve Seat/ Steel Ball/ Screen/ Gasket	<ul style="list-style-type: none"> Remove with a 22 mm (⁷/₈ in) socket wrench and extension bar, being very careful not to drop the steel ball and screen resting on top of the valve seat. Be careful not to lose the gasket. 	<ul style="list-style-type: none"> Make sure you are reinserting the intake (motive medium) valve seat, which has no holes. (The seat with the holes is the exhaust valve seat.) Make very sure you are reinserting the intake valve seat into the left hole in the top of the cover. (It is the hole with the plug in the top.) Insert the valve seat, with its gasket, from the bottom of the hole, then hand tighten. Remove the plug from the top with a 300 mm (12 in) adjustable wrench. Drop the screen straight into the hole, and then drop in the ball. Wrap plug threads with 3 – 3.5 turns of sealing tape or apply sealing compound. Check that the screen is seated straight, then reinsert the plug. Tighten the plug to a torque of 30 N·m (22 lbf·ft). Tighten the valve seat to a torque of 80 N·m (59 lbf·ft).
Exhaust: Valve Seat/ Gasket	<ul style="list-style-type: none"> Remove with a 22 mm (⁷/₈ in) socket wrench and extension bar. Be careful not to lose the gasket 	<ul style="list-style-type: none"> Make sure you are reinserting the exhaust valve seat, which has holes. (The seat with no holes is the intake valve seat.) Make very sure you are reinserting the exhaust valve seat into the right hole in the top of the body. (It is the hole with no plug in the top.) Insert the valve seat, with its gasket, from the bottom of the hole, hand tighten, then tighten to a torque of 80 N·m (59 lbf·ft).

(1 N·m ≈ 10 kg·cm)

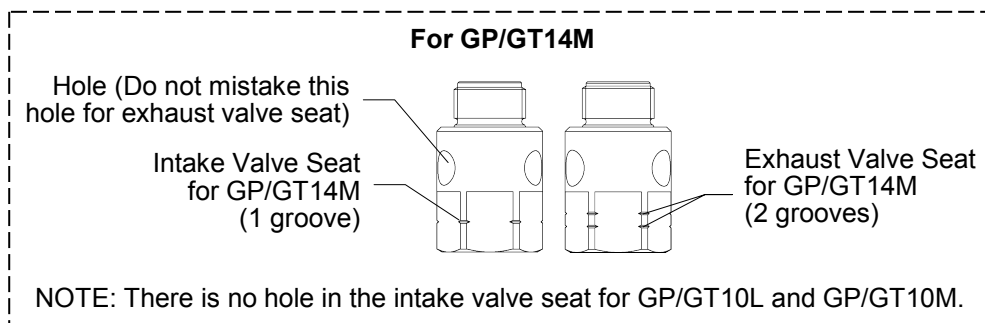
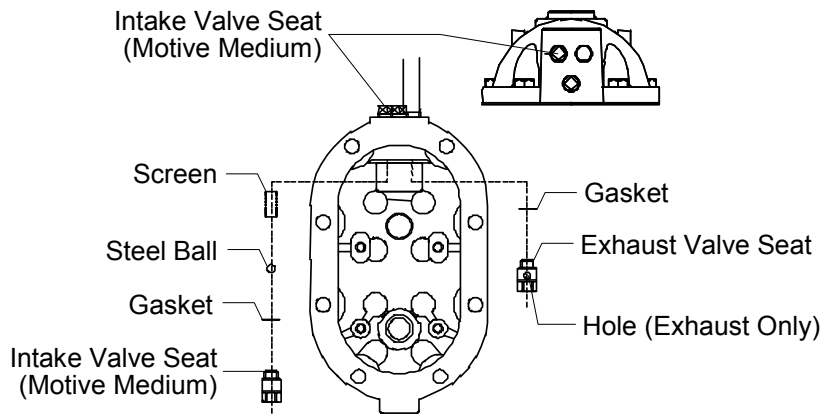

Troubleshooting



WARNING

NEVER apply direct heat to the float. The float may explode due to increased internal pressure, causing accidents leading to serious injury or damage to property and equipment.



CAUTION

DO NOT OPERATE the PowerTrap with piping disconnected. When it is absolutely necessary to operate with a portion of the outlet piping removed in order to examine an operational failure, open the motive medium and condensate inlet valves slowly, standing a safe distance from the open pipe section until the safety of this action is confirmed.



CAUTION

When disassembling or removing the product, wait until the internal pressure equals atmospheric pressure and the surface of the product has cooled to room temperature. Disassembling or removing the product when it is hot or under pressure may lead to discharge of fluids, causing burns, other injuries or damage.



CAUTION

Installation, inspection, maintenance, repairs, disassembly, adjustment and valve opening/closing should be carried out only by trained maintenance personnel.

When the desired performance is not attained with the system, in many cases it is due to the following:

- 1) Loose chips from pipe cutting and tapping, welding scraps or sealant, which catch in the intake valve (motive medium) or check valve and prevent them from closing/operating properly.
- 2) Changes in the amount of condensate inflow, motive pressure or back pressure that are in excess of the original design.

Since successful operation of the **PowerTrap** system depends on proper design and installation of the system, investigate the entire system to locate the source of problems when they occur. When no source can be identified, inspect the **PowerTrap** and take whatever action is necessary.

Determining the Problem from the Symptoms

Use the “Types of Failure and their Causes” table on the following page to determine the cause of the problem from the type of abnormality that has occurred.

Apply the corrective measures listed in the “Causes and Corrective Measures” table on pages 34 – 36.

Types of Failure and their Causes

Detailed explanations of the meanings of the numbers listed in the “Types of Failure” column are found in the “Causes and Corrective Measures” table on pages 34 – 36.

	Has the PowerTrap operated at least once?	Has pumped medium collected in the PowerTrap ?	Is there a continuous flowing sound from the motive medium supply pipe?	Is there a continuous flowing sound from the exhaust pipe?	Types of Failure (Category A – G) and Corrective Measures (Causes 1 – 5)										
					A	B	C	D	E	F	G				
PowerTrap Does Not Operate	NO	NO	NO	NO	1,2,3				1				3		
		YES	YES	YES						1					
	YES	YES	NO	NO	NO	1,4		1,2			5				
			YES	YES	YES								1		
			YES	YES	YES						2		1		
	YES	NO	NO	NO	NO		2			1					
			YES	YES	NO							3			
			YES	YES	YES								1		
			NO	NO	NO		1			1		3,4,5			
			YES	YES	NO									1	
PowerTrap Operates	Has pumped medium accumulated in the receiver/reservoir and backed up in the equipment?	YES	YES	YES									2	1	
	Is there any abnormal noise from the check valves?														
	Is there any abnormal noise from the pumped medium outlet pipe?						4								
	Is steam escaping from the exhaust pipe or reservoir/receiver?													1	

Causes and Corrective Measures

Category	Cause	Procedure
A. A valve on the pipeline is closed	<ol style="list-style-type: none"> 1. The valve on the motive medium supply pipe is closed 2. The valve on the exhaust pipe is closed 3. The valve on the condensate inlet pipe is closed 4. The valve on the condensate outlet pipe is closed 	<ul style="list-style-type: none"> • Slowly open the valve, using the proper procedure
B. The strainer is clogged	<ol style="list-style-type: none"> 1. The strainer on the motive medium supply pipe is clogged 2. The strainer on the condensate inlet pipe is clogged 	<ul style="list-style-type: none"> • Clean the strainer
C. Faulty motive, back or pumped medium inlet pressure	1. The motive medium supply pressure is less than the back pressure	<ul style="list-style-type: none"> • When the motive medium pressure is decreasing, adjust the pressure reducing valve on the supply pipe or connect to a separate high-pressure line • If the back pressure has increased, check to see if a steam trap connected to the pumped medium recovery line [Sr] is blowing (see drawings on pages 9 and 10) and check for any valves that have been left closed on the pumped medium recovery line • The motive medium pressure must be about 0.1 MPa (15 psi, 1 bar) higher than the back pressure (see page 11)
	2. Insufficient motive medium	<ul style="list-style-type: none"> • If the motive medium supply pipe is too small, change to a larger size pipe; the pipe should be at least 15 mm ($\frac{1}{2}$ in)
	3. When using the GP10L/GP10M/GP14M, the condensate inlet pressure exceeds the back pressure (see G.1. on page 36)	<ul style="list-style-type: none"> • When the pumped medium inlet pressure exceeds the back pressure, “blowthrough” occurs, i.e., steam flows into the pumped medium outlet pipe; in some cases, chattering on the outlet check valve or water hammer may also occur • The same thing will occur when the back pressure has decreased in a closed system • Check the reason that the pumped medium inlet pressure has increased and the back pressure has decreased and make any necessary repairs
	4. When using the GP10L/GP10M/GP14M, motive medium supply pressure is too high	<ul style="list-style-type: none"> • If the motive medium supply pressure is twice the back pressure or greater, “blowby” occurs, i.e., residual pressure at the end of the GP10L/GP10M motive medium supply process flows into the outlet pipe; when the temperature of the pumped medium in the recovery pipe is low, water hammer may also occur • The motive medium supply pressure should be reduced to a range within which the discharge flow does not drop below the required level

Category	Cause	Procedure
D. Faulty piping	1. The exhaust is abnormal	<ul style="list-style-type: none"> • Air-locking or vapor-locking has occurred; in the case of a closed system, the exhaust pipe is connected to the reservoir, but the pumped medium may not be exchanged for the medium inside the PowerTrap for the following reasons: <ol style="list-style-type: none"> (1) There is a U-shaped pipe between the exhaust port and the reservoir (2) The exhaust pipe has a diameter of less than 15 mm (1/2 in) (3) There is no air vent for steam on top of the reservoir or the steam equipment If (1), (2), or (3): Change the pipe or install an air vent • The distance from the ground to the highest point on the exhaust pipe is too great (over approx. 3 m (10 ft)) <p>For the GP10L/GP10M/GP14M: Add a steam trap to the exhaust pipe at a point just above where the exhaust pipe exits the body of the unit</p> <p>For the GT10L/GT10M/GT14M: Add piping connecting the exhaust pipe to the pumped medium inlet pipe between the reservoir and the strainer, being sure to install a check valve on the piping to prevent backflow of pumped medium from the pumped medium inlet pipe to the exhaust pipe</p>
	2. The filling head is insufficient 3. The pumped medium inlet pipe is too small 4. Not enough pumped medium is flowing through the pumped medium inlet valve	<ul style="list-style-type: none"> • Normal pumped medium flow will not be obtained if the filling head is smaller than that in the original design; the recommended filling head is 630 mm (25 in) • Normal pumped medium flow may not be obtained if the pumped medium inlet pipe is too small or the valve on the pumped medium inlet pipe is a needle valve or one with a small Cv value • The pipe and stop valve size must be increased to the design pipe size, and a full bore ball valve or gate valve must be used
E. Faulty PowerTrap	1. Dirt or scale is caught in the motive medium intake valve or the valve is worn 2. Dirt or scale is caught in the exhaust valve or the valve is worn 3. The snap-action unit is obstructed by dirt or scale or its operation is otherwise faulty 4. The float is broken 5. Dirt or scale is caught in the GT10L/GT10M/GT14M main valve (steam trap) unit, resulting in faulty valve opening/closing	<ul style="list-style-type: none"> • The PowerTrap does not operate for long periods of time, in spite of the fact that pumped medium has collected in the receiver/reservoir; if there is no sound at all of the operating medium flowing in the motive medium intake valve and the exhaust valve, it is possible that the PowerTrap is faulty <p>Note, however, that this phenomenon will also occur when the motive medium pressure is less than the back pressure</p> • If the PowerTrap does not operate for long periods of time and the sound of the operating medium can be heard continuously in the motive medium supply pipe, the PowerTrap is faulty <p>Disassemble the PowerTrap, and inspect the following items:</p> <ol style="list-style-type: none"> (1) Raise and lower the float and check to make sure the snap-action unit operates properly (2) Check the motive medium intake and exhaust valves to make sure there is no dirt or scale caught or any other abnormality (3) Check other possible factors that might hinder operation <p>After performing the above inspection, repair any defects discovered or replace the PowerTrap</p>

Category	Cause	Corrective Measure
F. Faulty check valve	1. Dirt or scale is caught in the pumped medium inlet check valve or the valve is worn or getting hung up	<ul style="list-style-type: none"> • The operating medium that has been supplied is leaking from the inlet check valve, preventing the pressure inside the trap from increasing; as a result, the pumped medium is not discharged Disassembly and inspection is required
	2. Dirt or scale is caught in the pumped medium outlet check valve or the valve is worn or getting hung up	<ul style="list-style-type: none"> • The discharged pumped medium has flowed back into the PowerTrap, causing the interval at which the unit operates to grow shorter and reducing its discharge capacity Disassembly and inspection is required
	3. The pumped medium inlet or outlet check valves have been installed in the wrong direction	<ul style="list-style-type: none"> • Correct the installation so that the check valve is facing the right way to allow the desired flow of pumped medium
	4. The pumped medium inlet or outlet check valves are too small	<ul style="list-style-type: none"> • The pumped medium flow capacity is insufficient Use a larger size
G. There is a problem with other equipment	1. A large quantity of steam is flowing into the receiver/reservoir	<ul style="list-style-type: none"> • When a large quantity of steam is discharged from the exhaust pipe or vent pipe, it may be because steam from a blowing steam trap or an open valve has flowed into the pumped medium inflow pipe system of the receiver/reservoir; check these traps and the valves on the pumped medium inflow pipe system

Product Warranty

1. Warranty Period
One year following product delivery.
2. Warranty Coverage
TLV CO., LTD. warrants this product to the original purchaser to be free from defective materials and workmanship. Under this warranty, the product will be repaired or replaced at our option, without charge for parts or labor.
3. This product warranty will not apply to cosmetic defects, nor to any product whose exterior has been damaged or defaced; nor does it apply in the following cases:
 - 1) Malfunctions due to improper installation, use, handling, etc., by other than TLV CO., LTD. authorized service representatives.
 - 2) Malfunctions due to dirt, scale, rust, etc.
 - 3) Malfunctions due to improper disassembly and reassembly, or inadequate inspection and maintenance by other than TLV CO., LTD. authorized service representatives.
 - 4) Malfunctions due to disasters or forces of nature.
 - 5) Accidents or malfunctions due to any other cause (such as water hammer) beyond the control of TLV CO., LTD.
4. Under no circumstances will TLV CO., LTD. be liable for consequential economic loss damage or consequential damage to property.

Service

For Service or Technical Assistance:
Contact your **TLV** representative or your **TLV** office.

In Europe:

TLV EURO ENGINEERING GmbH

Daimler-Benz-Straße 16-18, 74915 Waibstadt, **Germany**
Tel: [49]-(0)7263-9150-0 Fax: [49]-(0)7263-9150-50

TLV EURO ENGINEERING UK LTD.

Star Lodge, Montpellier Drive, Cheltenham, Gloucestershire, GL50 1TY, **U.K.**
Tel: [44]-(0)1242-227223 Fax: [44]-(0)1242-223077

TLV EURO ENGINEERING FRANCE SARL

Parc d'Ariane 2, bât. C, 290 rue Ferdinand Perrier, 69800 Saint Priest, **France**
Tel: [33]-(0)4-72482222 Fax: [33]-(0)4-72482220

In North America:

TLV CORPORATION

13901 South Lakes Drive, Charlotte, NC 28273-6790, **U.S.A.**
Tel: [1]-704-597-9070 Fax: [1]-704-583-1610

In Mexico:

TLV ENGINEERING S. A. DE C.V.

San Andrés Atoto No. 12, Col. San Andrés Atoto 53500,
Naucalpan, Edo. de México, **Mexico**
Tel: [52]-55-5359-7949 Fax: [52]-55-5359-7585

In Argentina:

TLV ENGINEERING S. A.

Av. Mitre 775, B1603CQH Villa Martelli, Pcia. Buenos Aires, **Argentina**
Tel: [54]-(0)11-4760-8401 Fax: [54]-(0)11-4761-6793

In Oceania:

TLV PTY LIMITED

Unit 22, 137-145 Rooks Road, Nunawading, Victoria 3131, **Australia**
Tel: [61]-(0)3-9873 5610 Fax: [61]-(0) 3-9873 5010

In East Asia:

TLV PTE LTD

66 Tannery Lane, #03-10B Sindo Building, **Singapore** 347805
Tel: [65]-6747 4600 Fax: [65]-6742 0345

TLV SHANGHAI CO., LTD.

Room 1306, No. 103 Cao Bao Road, Shanghai, **China** 200233
Tel: [86]-21-5102-1669 Fax: [86]-21-6482-8623

TLV ENGINEERING SDN. BHD.

8 & 8A, Jalan BP 6/6, Bandar Bukit Puchong,
47120 Puchong, Selangor, **Malaysia**
Tel: [60]-3-8065-2928 Fax: [60]-3-8065-2923

TLV INC.

#302-1 Bundang Technopark B
Yatap, Bundang, Seongnam, Gyeonggi, 463-760 **Korea**
Tel: [82]-(0)31-726-2105 Fax: [82]-(0)31-726-2195

Or:

TLV INTERNATIONAL, INC.

881 Nagasuna, Noguchi, Kakogawa, Hyogo 675-8511, **Japan**
Tel: [81]-(0)79-427-1818 Fax: [81]-(0)79-425-1167

Manufacturer:

TLV CO., LTD.

881 Nagasuna, Noguchi, Kakogawa, Hyogo 675-8511, **Japan**
Tel: [81]-(0)79-422-1122 Fax: [81]-(0)79-422-0112