



Instruction Manual

Free Float Steam Trap with X-element
J3X• JF3X/J5X• JF5X/J7X
J7.2X/J7.5X/J8X

Contents

Introduction	1
Safety Considerations	2
Checking the Piping	4
Operation	5
Specifications	6
Configuration	7
Installation	9
Maintenance.....	10
Operating the Optional Lock Release Valve	11
Disassembly/Reassembly	13
Troubleshooting	19
TLV EXPRESS LIMITED WARRANTY	20
Service	22
Option: Pressure-balancing Line Connection (no X-element)	23

Introduction

Thank you for purchasing the TLV free float steam trap.

This product has been thoroughly inspected before being shipped from the factory. When the product is delivered, before doing anything else, check the specifications and external appearance to make sure nothing is out of the ordinary. Also be sure to read this manual carefully before use and follow the instructions to be sure of using the product properly.

This free float steam trap is of a revolutionary design that employs a high-performance X-element in its air vent. It is best suited for steam equipment use.

The X-element is very sensitive to changes in temperature, and responds with great accuracy, allowing for the quick discharge of large quantities of initial air and cold condensate immediately after operation start-up. It also reacts with great sensitivity to the inflow of large quantities of condensate and hot air during operation, preventing air binding.

This steam trap, which combines the superior features of the X-element with the proven performance record of the free float, increases heating efficiency and reduces manpower requirements for maintenance and bypass blowdown.







If detailed instructions for special order specifications or options not contained in this manual are required, please contact TLV for full details.

This instruction manual is intended for use with the model(s) listed on the front cover. It is necessary not only for installation, but for subsequent maintenance, disassembly/reassembly and troubleshooting. Please keep it in a safe place for future reference.

Safety Considerations

- Read this section carefully before use and be sure to follow the instructions.
- Installation, inspection, maintenance, repairs, disassembly, adjustment and valve opening/closing should be carried out only by trained maintenance personnel.
- The precautions listed in this manual are designed to ensure safety and prevent equipment damage and personal injury. For situations that may occur as a result of erroneous handling, three different types of cautionary items are used to indicate the degree of urgency and the scale of potential damage and danger: DANGER, WARNING and CAUTION.
- The three types of cautionary items above are very important for safety: be sure to observe all of them as they relate to installation, use, maintenance and repair. Furthermore, TLV accepts no responsibility for any accidents or damage occurring as a result of failure to observe these precautions.

Symbols

	Indicates a DANGER, WARNING or CAUTION item.
 DANGER	Indicates an urgent situation which poses a threat of death or serious injury
 WARNING	Indicates that there is a potential threat of death or serious injury
 CAUTION	Indicates that there is a possibility of injury or equipment/product damage
 WARNING	NEVER apply direct heat to the float. The float may explode due to increased internal pressure, causing accidents leading to serious injury or damage to property and equipment.
 CAUTION	Install properly and DO NOT use this product outside the recommended operating pressure, temperature and other specification ranges. Improper use may result in such hazards as damage to the product or malfunctions that may lead to serious accidents. Local regulations may restrict the use of this product to below the conditions quoted.
	DO NOT use this product in excess of the maximum operating pressure differential. Such use could make discharge impossible (blocked).
	Use hoisting equipment for heavy objects (weighing approximately 20 kg (44 lb) or more). Failure to do so may result in back strain or other injury if the object should fall.
	Take measures to prevent people from coming into direct contact with product outlets. Failure to do so may result in burns or other injury from the discharge of fluids.

Continued on the next page

 CAUTION	<p>Use gloves when operating the lock release valve and keep all body parts well clear of the product. Failure to do so could result in burns, other injury or damage from the blowing of small amounts of steam and condensate.</p>
	<p>When disassembling or removing the product, wait until the internal pressure equals atmospheric pressure and the surface of the product has cooled to room temperature. Disassembling or removing the product when it is hot or under pressure may lead to discharge of fluids, causing burns, other injuries or damage.</p>
	<p>Be sure to use only the recommended components when repairing the product, and NEVER attempt to modify the product in any way. Failure to observe these precautions may result in damage to the product and burns or other injury due to malfunction or the discharge of fluids.</p>
	<p>Do not use excessive force when connecting threaded pipes to the product. Over-tightening may cause breakage leading to fluid discharge, which may cause burns or other injury.</p>
	<p>Use only under conditions in which no freeze-up will occur. Freezing may damage the product, leading to fluid discharge, which may cause burns or other injury.</p>
	<p>Use only under conditions in which no water hammer will occur. The impact of water hammer may damage the product, leading to fluid discharge, which may cause burns or other injury.</p>

Checking the Piping



Use only under conditions in which no water hammer will occur.

The impact of water hammer may damage the product, leading to fluid discharge, which may cause burns or other injury.

Check to make sure that the pipes to be connected to the trap have been installed properly.

1. Is the pipe diameter suitable?
2. Is the piping where the product is to be installed horizontal?
3. Has sufficient space been secured for maintenance?
4. Have isolation valves been installed at the inlet and outlet? If the outlet is subject to back pressure, has a check valve (TLV-CK) been installed?
5. Is the inlet pipe as short as possible, with as few bends as possible, and installed so the liquid will flow naturally down into the trap?
6. Has the piping work been done correctly, as shown in the figures below?

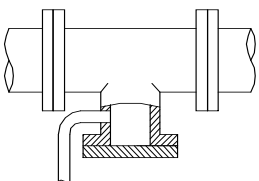
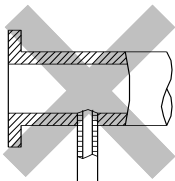
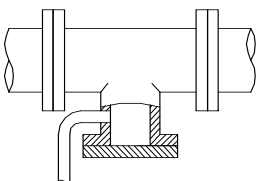
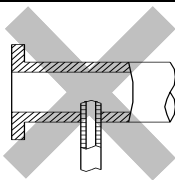
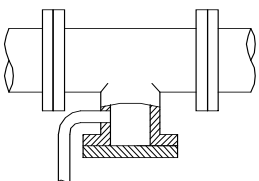
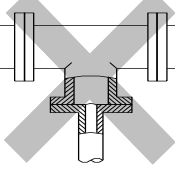
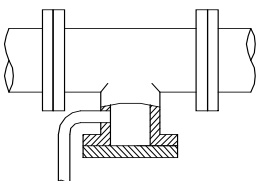
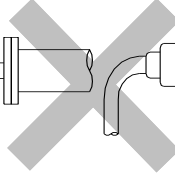
Requirement	Correct	Incorrect
Install catchpot with the proper diameter.		 Diameter is too small.
Make sure the flow of condensate is not obstructed.		 Diameter is too small and inlet protrudes into pipe interior.
To prevent rust and scale from flowing into the trap, the inlet pipe should be connected 25 to 50 mm (1 to 2 in) above the base of the T-pipe.		 Rust and scale flow into the trap with the condensate.
When installing on the blind end, make sure the flow of condensate is not obstructed.		 Condensate collects in the pipe.

Operation

Principles of air and condensate discharge:

1. Initial Air and Cold Condensate Discharge

At startup, before steam is supplied, the trap is cold so the X-element is contracted and the air vent valve seat (A) is open. This allows for the rapid discharge of air through the air vent valve (A) and cold condensate through the orifice (B), when steam is first supplied to the system.

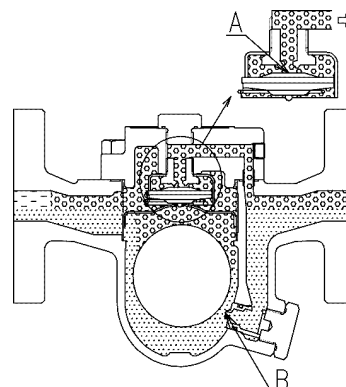

2. Condensate Discharge

After the discharge of initial air and cold condensate, the heat of the inflowing steam and condensate causes the X-element to expand, closing the air vent valve (A). The rising condensate level causes the float to rise due to buoyancy, opening the orifice (B) and allowing condensate to be discharged.

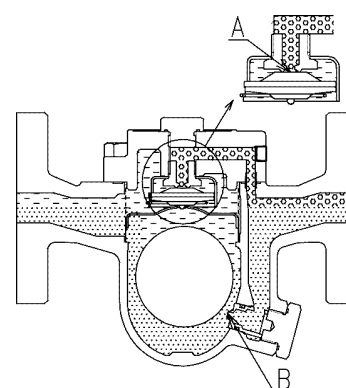

3. Hot Air Discharge

Should hot air flow into the trap with the steam during normal operation, the temperature of the X-element drops, causing it to momentarily contract and open the air vent valve (A), which allows for the rapid discharge of the air. After the air is discharged and steam contacts the X-element, the temperature will increase causing the air vent valve (A) to close.

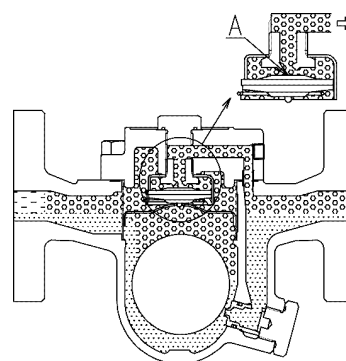

4. Closed Position

When the condensate flow rate decreases, the float falls as condensate is discharged, closing off the orifice (B). A water seal is maintained at all times over the orifice (B) to prevent steam loss. Note: the high steam temperature causes the X-element to expand, keeping the air vent closed.

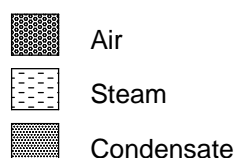
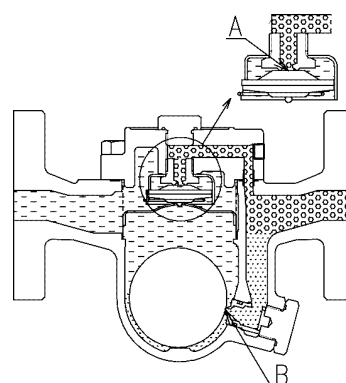

Specifications

 CAUTION	Install properly and DO NOT use this product outside the recommended operating pressure, temperature and other specification ranges. Improper use may result in such hazards as damage to the product or malfunctions that may lead to serious accidents. Local regulations may restrict the use of this product to below the conditions quoted.
	DO NOT use this product in excess of the maximum operating pressure differential. Such use could make discharge impossible (blocked).
	Use only under conditions in which no freeze-up will occur. Freezing may damage the product, leading to fluid discharge, which may cause burns or other injury.

Refer to the product nameplate for detailed specifications.

J3X/JF3X

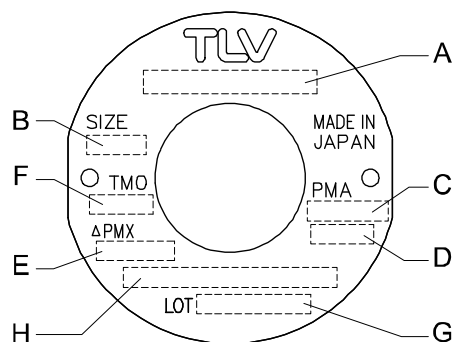

J5X/JF5X/J7X/J7.2X/J7.5X/J8X

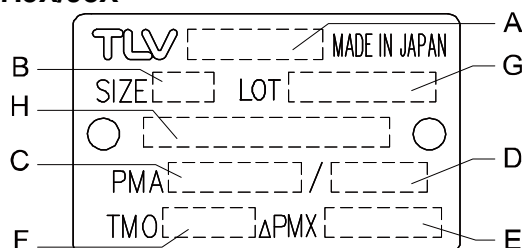

A	Model
B	Nominal Diameter
C	Maximum Allowable Pressure (PMA)*
D	Maximum Allowable Temperature (TMA)*
E	Maximum Differential Pressure (PMX)
F	Maximum Operating Temperature (TMO)
G	Production Lot No.
H	Valve No.**

* Maximum allowable pressure (PMA) and maximum allowable temperature (TMA) are PRESSURE SHELL DESIGN CONDITIONS, **NOT** OPERATING CONDITIONS.

** Valve No. is displayed for products with options. This item is omitted from the nameplate when there are no options.

Configuration

J3X/JF3X/J5X/JF5X

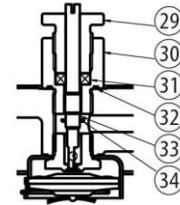
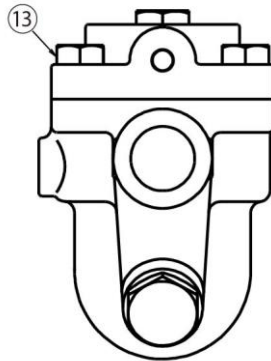
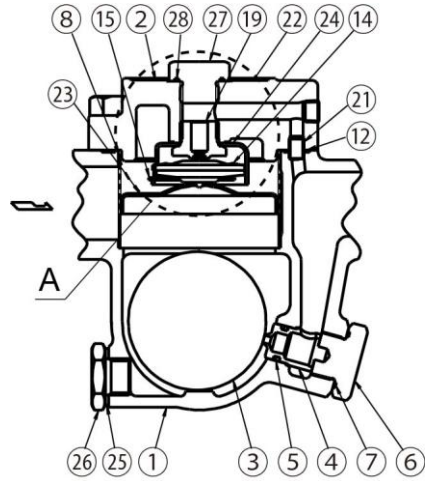

A

J7X/J7.5X/J8X

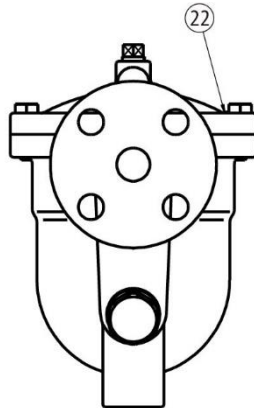
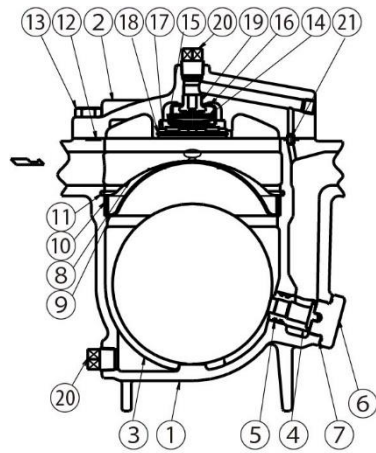

J7.2X

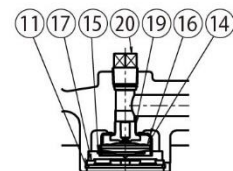
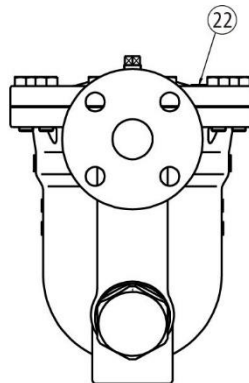
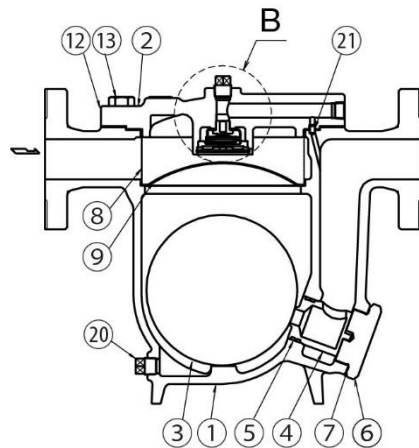

B

No.	Part Name	Maintenance Kit	Repair Kit	Float
1	Body			
2	Cover			
3	Float			✓
4	Orifice		✓	
5	Orifice O-ring	✓	✓	
6	Orifice Holder Plug			
7	Orifice Plug Gasket	✓	✓	
8	Screen		✓	
9	Screen Holder			
10	Screen Holder Retainer			
11	Snap Ring			
12	Cover Gasket	✓	✓	
13	Cover Bolt			
14	X-element		✓	
15	Spring Clip		✓	
16	X-element Guide		✓	
17	X-element Cover		✓ ³⁾	
18	Snap Ring		✓ ³⁾	
19	Air Vent Valve Seat		✓	
20	Plug/Drain Plug			
21	Connector			
22	Nameplate			
23	Float Cover		✓ ⁴⁾	
24	X-element Guide			
25	Drain Plug Gasket ¹⁾	✓ ⁴⁾	✓ ⁴⁾	
26	Drain Plug ¹⁾			
27	Plug			
28	Plug Gasket	✓ ⁴⁾	✓ ⁴⁾	
29	Gland Retainer Nut			
30	Gland Case			
31	Gland Packing			
32	Gasket			
33	Element Retainer			
34	Spring Pin			
A	Lock Release Valve ²⁾			

¹⁾ Option for J3X and J5X

²⁾ Option: LR3 for J3X and JF3X, LR5 for J4X and JF5X

³⁾ For J7X, J7.2X, J7.5X, and J8X

⁴⁾ For J3X, JF3X, J5X, and JF5X

Installation

 CAUTION	Install properly and DO NOT use this product outside the recommended operating pressure, temperature and other specification ranges. Improper use may result in such hazards as damage to the product or malfunctions that may lead to serious accidents. Local regulations may restrict the use of this product to below the conditions quoted.
	Use hoisting equipment for heavy objects (weighing approximately 20 kg or more). Failure to do so may result in back strain or other injury if the object should fall.
	Take measures to prevent people from coming into direct contact with product outlets. Failure to do so may result in burns or other injury from the discharge of fluids.
	Do not use excessive force when connecting threaded pipes to the product. Over-tightening may cause breakage leading to fluid discharge, which may cause burns or other injury.

Installation, inspection, maintenance, repairs, disassembly, adjustment and valve opening/closing should be carried out only by trained maintenance personnel.

1. Before installation, be sure to remove all protective seals.
2. Before installing the product, blow out the inlet piping to remove any piping scraps, dirt and oil. Close the inlet valve after blowdown.
3. Install the product so that the arrow on the body is pointing in the direction of flow.
4. The product should be inclined no more than 5° horizontally and front-to-back.
5. Install a condensate outlet valve and outlet piping.
6. Open the inlet and outlet valves and ensure that the product functions properly.

If there is a problem, determine the cause using the “Troubleshooting” section in this manual.

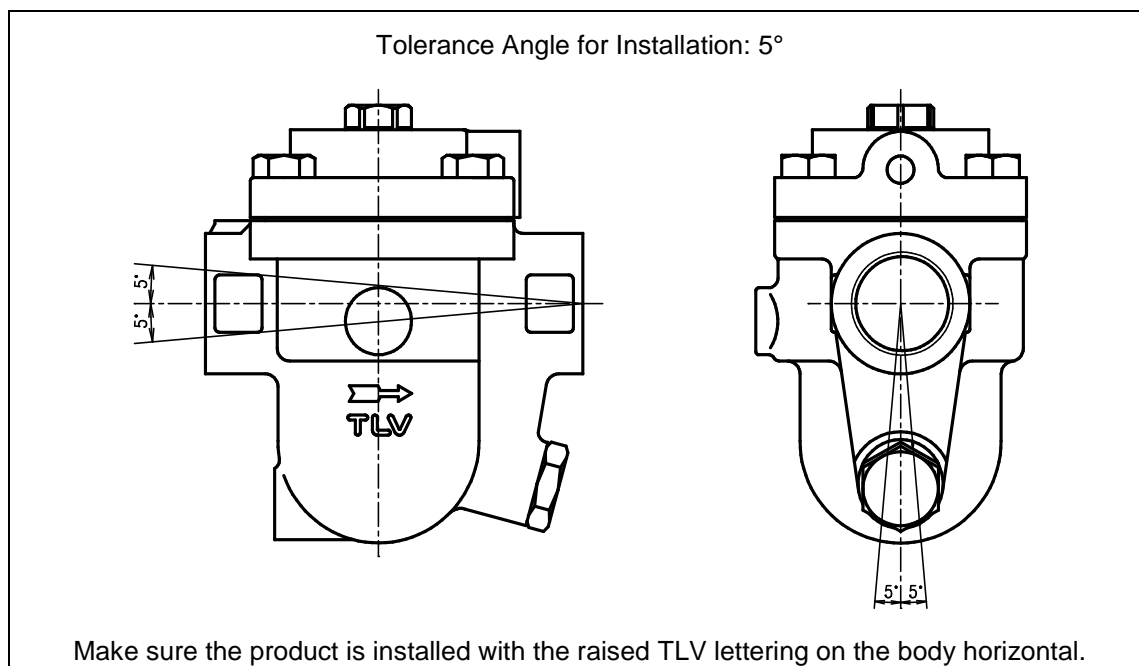

Maintenance

 CAUTION	Take measures to prevent people from coming into direct contact with product outlets. Failure to do so may result in burns or other injury from the discharge of fluids.
	Be sure to use only the recommended components when repairing the product, and NEVER attempt to modify the product in any way. Failure to observe these precautions may result in damage to the product and burns or other injury due to malfunction or the discharge of fluids.

Operational Check

A visual inspection of the following items should be done on a daily basis to determine whether the product is operating properly or has failed. Periodically (at least biannually) the operation should also be checked by using diagnostic equipment such as a stethoscope, thermometer, TLV Pocket TrapMan or TLV TrapMan.

If the product should fail, it may cause damage to piping and equipment, resulting in faulty or low quality products or losses due to steam leakage.

- Normal : Condensate is discharged continuously, together with flash steam, and the sound of flow can be heard. If there is very little condensate, there is almost no sound of flow.
- Blocked (Discharge Impossible) : No condensate is discharged. The product is quiet and makes no noise, and the surface temperature of the product is low.
- Blowing : Live steam continually flows from the outlet and there is a continuous metallic sound.
- Steam Leakage : Live steam is discharged through the product outlet together with condensate, accompanied by a high-pitched sound.

(When conducting a visual inspection, flash steam is sometimes mistaken for steam leakage. For this reason, the use of a steam trap diagnostic instrument such as TLV TrapMan in conjunction with the visual inspection is highly recommended.)

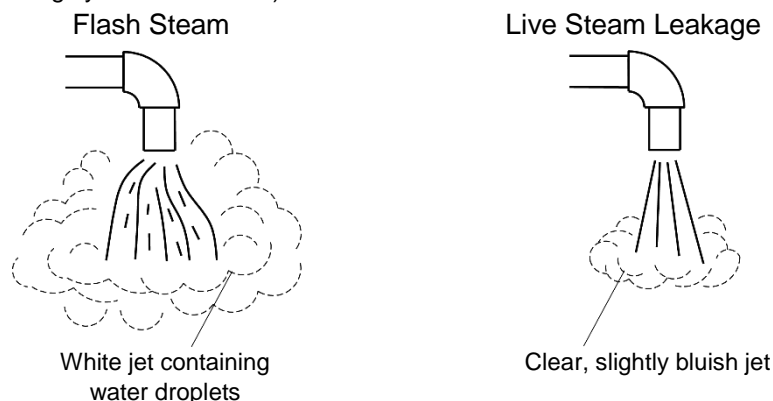

Parts Inspection

When parts have been removed, or during periodic inspections, use the following table to inspect the parts and replace any that are found to be defective.

Procedure	
Gasket:	Check for warping or damage
Screen:	Check for clogging or corrosion
X-element, Air Vent Valve Seat:	Check for damage
Float:	Check for scratches or dents
After cleaning the inside of the body,	
Orifice O-ring:	Check for warping or damage
Orifice Opening:	Check dirt, oil film, wear and damage

Operating the Optional Lock Release Valve



Use only under conditions in which no water hammer will occur.

The impact of water hammer may damage the product, leading to fluid discharge, which may cause burns or other injury.

Use on equipment where steam-locking/air binding, which slows the discharge of condensate and reduces equipment efficiency, tends to occur (cylindrical dryers, air fin heater, etc.).

- When the product is shipped from the factory, the element retainer is raised in the maximum, valve-closed position.
- Before operating the lock release valve, examine the trap outlet and confirm that the trap is functioning properly.
- Operate the lock release valve as follows:
Tools required: flat-head screwdriver
 - Open Valve
 - Insert the screwdriver into the slot on the top of the element retainer and slowly turn clockwise.
(Do not continue turning the element retainer past the point at which it stops.)
 - See charts below for steam discharge/air discharge. (Maximums are shown.)
 - Close Valve
 - Insert the screwdriver into the slot on the top of the element retainer and close by turning counterclockwise.
 - Raise the element retainer until the snap ring contacts the bottom of the gland case.
(Do not continue turning the element retainer past the point at which it stops.)
- If steam should leak from the gland retainer nut or gland case, it can be stopped by further tightening the gland retainer nut.
(Do not over tighten, otherwise element retainer may seize and become unworkable.)

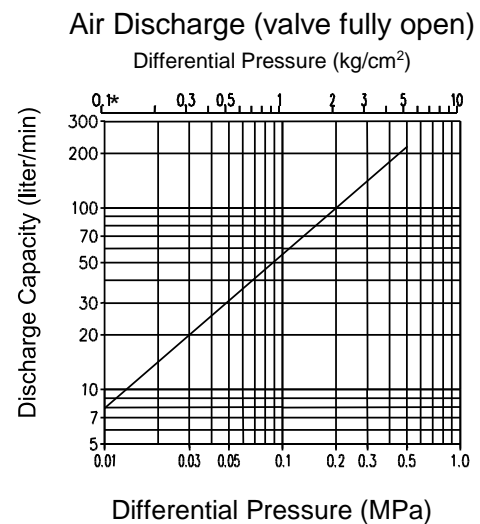
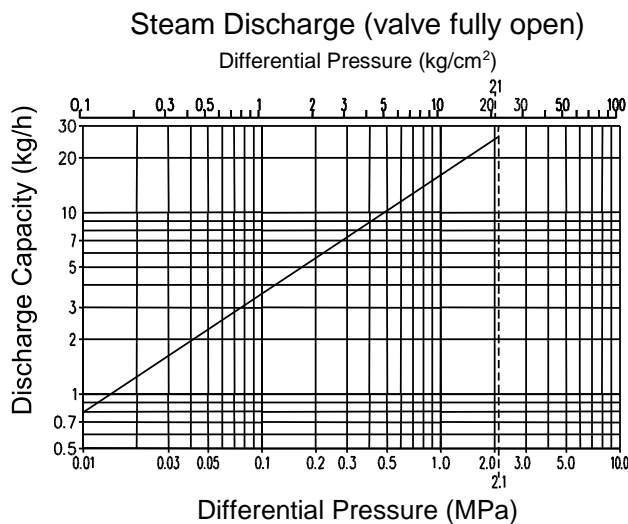

* Capacities are equivalent capacities of standard air (air at 20 °C and atmospheric pressure.)

Steam Discharge (valve fully open)

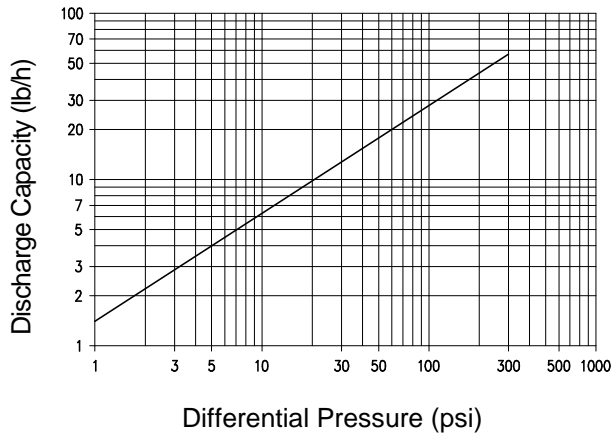

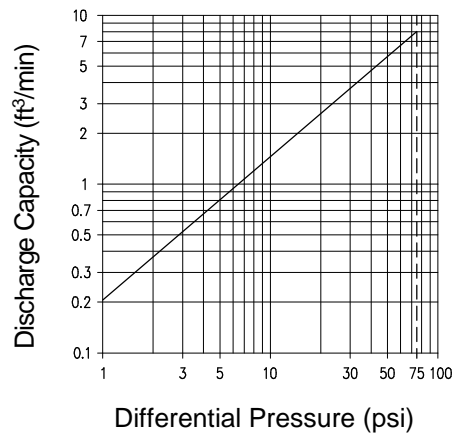

Air Discharge (valve fully open)



* Capacities are equivalent capacities of standard air (air at 68°F and atmospheric pressure)

Disassembly/Reassembly

 WARNING	NEVER apply direct heat to the float. The float may explode due to increased internal pressure, causing accidents leading to serious injury or damage to property and equipment.
 CAUTION	Use hoisting equipment for heavy objects (weighing approximately 20 kg (44 lb) or more). Failure to do so may result in back strain or other injury if the object should fall. When disassembling or removing the product, wait until the internal pressure equals atmospheric pressure and the surface of the product has cooled to room temperature. Disassembling or removing the product when it is hot or under pressure may lead to discharge of fluids, causing burns, other injuries or damage.

Use the following procedures to remove components. Use the same procedures in reverse to reassemble. (Installation, inspection, maintenance, repairs, disassembly, adjustment and valve opening/closing should be carried out only by trained maintenance personnel.)

Disassembling/Reassembling Optional* Lock Release Valve

Part	J(F)3X J(F)5X	J7.2X	J7X J7.5X J8X	During Disassembly	During Reassembly
Gland Case 30	✓	–	–	Remove with a socket wrench	Consult the table of tightening torques and tighten to the proper torque
Gasket 32	✓	–	–	Remove the gasket and clean sealing surfaces	Replace with a new gasket if warped or damaged
Gland Retainer Nut 29 *	✓	–	–	Remove with a socket wrench	Consult the table of tightening torques and tighten to the proper torque
Gland Packing 31	✓	–	–	Remove, being careful not to scratch the inside of the gland case	Replace with a new gland packing
Spring Pin 34	✓	–	–	Squeeze and remove	Insert until equal lengths of the pin are visible on both sides of the element retainer
Element Retainer 33	✓	–	–	Remove while turning	—

* Stamped 3 or 5: 3 for J3X and JF3X, 5 for J5X and JF5X

Figure A

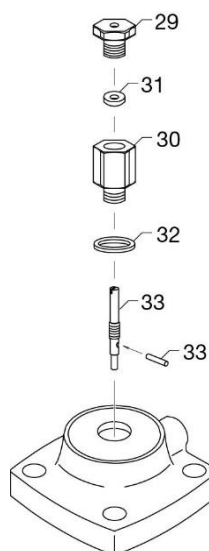

Removing/Reattaching Drain Plug

Part	J(F)3X J(F)5X	J7.2X	J7X J7.5X J8X	During Disassembly	During Reassembly
Drain Plug 19	✓*	–	–	Remove with a socket wrench	Coat threads with anti-seize; consult the table of tightening torques and tighten to the proper torque
Drain Plug Gasket 20	✓*	–	–	Remove the gasket and clean sealing surfaces	Replace with a new gasket
Drain Plug 19	–	✓	✓	Remove with a socket wrench	Wrap threads with sealing tape, consult the table of tightening torques and tighten to the proper torque

* Option

Removing/Reattaching Cover

Part	J(F)3X J(F)5X	J7.2X	J7X J7.5X J8X	During Disassembly	During Reassembly
Plug 24	✓	–	–	Remove with a socket wrench	Coat threads with anti-seize; consult the table of tightening torques and tighten to the proper torque
Plug Gasket 25	✓	–	–	Remove the gasket and clean sealing surfaces	Replace with a new gasket if warped or damaged; coat surfaces with anti-seize
Plug 24	–	✓	✓	Remove with a socket wrench	Wrap threads with sealing tape, consult the table of tightening torques and tighten to the proper torque
Cover Bolt 23	✓	✓	✓	Remove with a socket wrench	Coat threads with anti-seize; consult the table of tightening torques and tighten to the proper torque
Cover 2	✓	✓	✓	Lift the cover up and off	Make sure there are no pieces of the old gasket left on the sealing surfaces of the body and cover; align the cover with the connector and reattach
Connector 22	✓	✓	✓	Remove the connector	Place in its hole in the body
Cover Gasket 3	✓	✓	✓	Remove the gasket and clean sealing surfaces	J(F)3X/J(F)5X/J(S)7X/J7LX: Replace with a new gasket if damaged J7.2X/J7.5X/J8X: Replace with a new gasket

Figure B

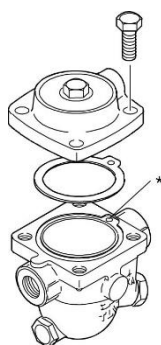

*Hole for connector

Removing/Reassembling Components Inside the Cover

Part	J(F)3X J(F)5X	J7.2X	J7X J7.5X J8X	During Disassembly	During Reassembly
Snap Ring 18 (X-element Cover 17)	–	✓	✓	Pinch the insides together and remove	Insert securely into the snap ring groove in the cover
X-element Cover 17	–	✓	✓	—	Make sure the mesh side is facing the float
Spring Clip 16 (X-element 14)	✓	✓	✓	Pinch the insides together and remove from the X-element guide	Insert securely into the slot in the X-element guide
X-element 14	✓	✓	✓	Remove from the X-element guide	Make sure the correct side of the X-element is facing up
Air Vent Valve Seat 21	✓	✓	✓	Remove with a socket wrench	Coat threads with anti-seize; consult the table of tightening torques and tighten to the proper torque
X-element Guide 15	✓	✓	✓	Remove without bending	Fix with the Air Vent Valve and make sure the X-element can be inserted smoothly

Figure C

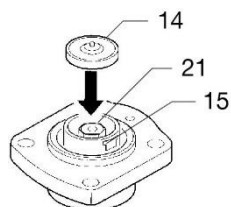

Removing/Reassembling Components Inside the Body

Configuration of screen components differs according to the model.

Part	J(F)3X J(F)5X	J7.2X	J7X J7.5X J8X	During Disassembly	During Reassembly
Snap Ring 18 (Screen 9)	–	–	✓	Pinch the insides together and remove	Insert securely into the snap ring groove
Screen 9 (Float Cover 12)	✓	–	–	Remove by lifting straight up and out while turning	Align the arrow on the screen (float cover) with the arrow on the body and insert, fitting the tab on the bottom of the screen (float cover) into the guide in the body and making sure the top of the screen (float cover) does not stick up out of the body (Figure D)
Screen 9	–	✓	–	Lift straight up and out	Place on the screen holder, making sure that the top of the screen does not stick up out of the body
	–	–	✓	Lift straight up and out	Place on the screen holder retainer, making sure the rounded side is on top

Continued on the next page

Part	J(F)3X J(F)5X	J7.2X	J7X J7.5X J8X	During Disassembly	During Reassembly
Screen Holder Retainer 11	-	-	✓	Lift straight up and out	Insert into the body straight
Screen Holder 10	-	✓	✓	Lift straight up and out	Insert into body, making sure the rounded side is on top
Float 4	✓	✓	✓	Remove, being careful not to scratch the polished surface	Insert, being careful not to scratch or misshape
Orifice Holder Plug 7	✓	✓	✓	Remove with a socket wrench	Coat threads with anti-seize; consult the table of tightening torques and tighten to the proper torque
Orifice Holder Gasket 8	✓	✓	✓	Remove the gasket and clean sealing surfaces	Replace with a new gasket if damaged
Orifice 5	✓	✓	✓	Push out from inside the body toward the orifice plug holder	Insert with the proper orientation (figure E): insert from the outside of the body, pushing in until it contacts the stopper inside; if the condensate discharge hole is pointing sideways, extended use may result in a hole in the body
Orifice O-Ring 6	✓	✓	✓	Remove, being careful not to damage the rubber orifice O-ring	Coat with heat-resistant grease; use a new orifice O-ring whenever replacing the orifice

Figure D

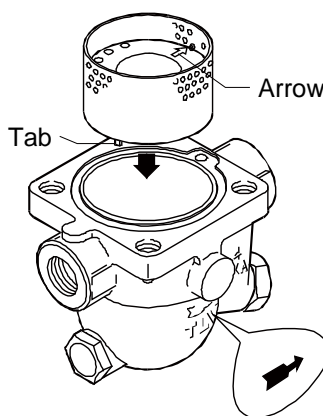

Figure E

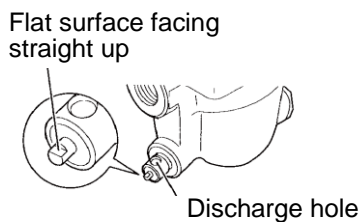

Table of Tightening Torques

Parts	Model	J3X/JF3X	J5X/JF5X	J7X	J7.2X	J7.5X	J8X	
Cover Bolt 23	Torque	N·m (lbf·ft)	50 (37)	80 (59)	70 (51)	110 (81)	160 (115)	250 (185)
	Distance Across Flats	mm (in)	17 ($2\frac{1}{32}$)	22 ($\frac{7}{8}$)	17 ($2\frac{1}{32}$)	22 ($\frac{7}{8}$)	24 ($\frac{15}{16}$)	32 ($1\frac{1}{4}$)
Air Vent Valve Seat 21	Torque	N·m (lbf·ft)	35 (26)	35 (26)	35 (26)	35 (26)	35 (26)	35 (26)
	Distance Across Flats	mm (in)	19 ($\frac{3}{4}$)	19 ($\frac{3}{4}$)	19 ($\frac{3}{4}$)	19 ($\frac{3}{4}$)	19 ($\frac{3}{4}$)	19 ($\frac{3}{4}$)
Plug 24	Torque	N·m (lbf·ft)	30 (22)	30 (22)	30** (22)**	30** (22)**	30** (22)**	30** (22)**
	Distance Across Flats	mm (in)	19 ($\frac{3}{4}$)	19 ($\frac{3}{4}$)	12 ($\frac{15}{32}$)	12 ($\frac{15}{32}$)	12 ($\frac{15}{32}$)	12 ($\frac{15}{32}$)
Orifice Holder Plug 7	Torque	N·m (lbf·ft)	50 (37)	80 (59)	120 (88)	400 (290)	600 (440)	800 (590)
	Distance Across Flats	mm (in)	24 ($\frac{15}{16}$)	32 ($1\frac{1}{4}$)	36 ($1\frac{13}{32}$)	70 ($2\frac{3}{4}$)	85 ($3\frac{11}{32}$)	105 ($4\frac{1}{8}$)
Drain Plug 19	Torque	N·m (lbf·ft)	35* (26)*	35* (26)*	30** (22)**	30** (22)**	40** (29)**	40** (29)**
	Distance Across Flats	mm (in)	21 ($\frac{13}{16}$)	21 ($\frac{13}{16}$)	12 ($\frac{15}{32}$)	12 ($\frac{15}{32}$)	14 ($\frac{9}{16}$)	14 ($\frac{9}{16}$)
Gland Retainer Nut 29 *** (Optional)	Torque	N·m (lbf·ft)	15 (11)	15 (11)	— —	— —	— —	— —
	Distance Across Flats	mm (in)	22 ($\frac{7}{8}$)	22 ($\frac{7}{8}$)	— —	— —	— —	— —
Gland Case 30*** (Optional)	Torque	N·m (lbf·ft)	30 (22)	30 (22)	— —	— —	— —	— —
	Distance Across Flats	mm (in)	19 ($\frac{3}{4}$)	19 ($\frac{3}{4}$)	— —	— —	— —	— —

* Option

(1 N·m \approx 10 kg·cm)

** These values represent tightening torques for threads that are wrapped with 3 to 3.5 turns of sealing tape.

*** Gland retainer nut and gland case are lock release valve (LR3, LR5) parts. Do not use sealing tape or anti-seize.

NOTE: - Coat all threaded portions with anti-seize.

- If drawings or other special documentation were supplied for the product, any torque given there takes precedence over values shown here.

Exploded View

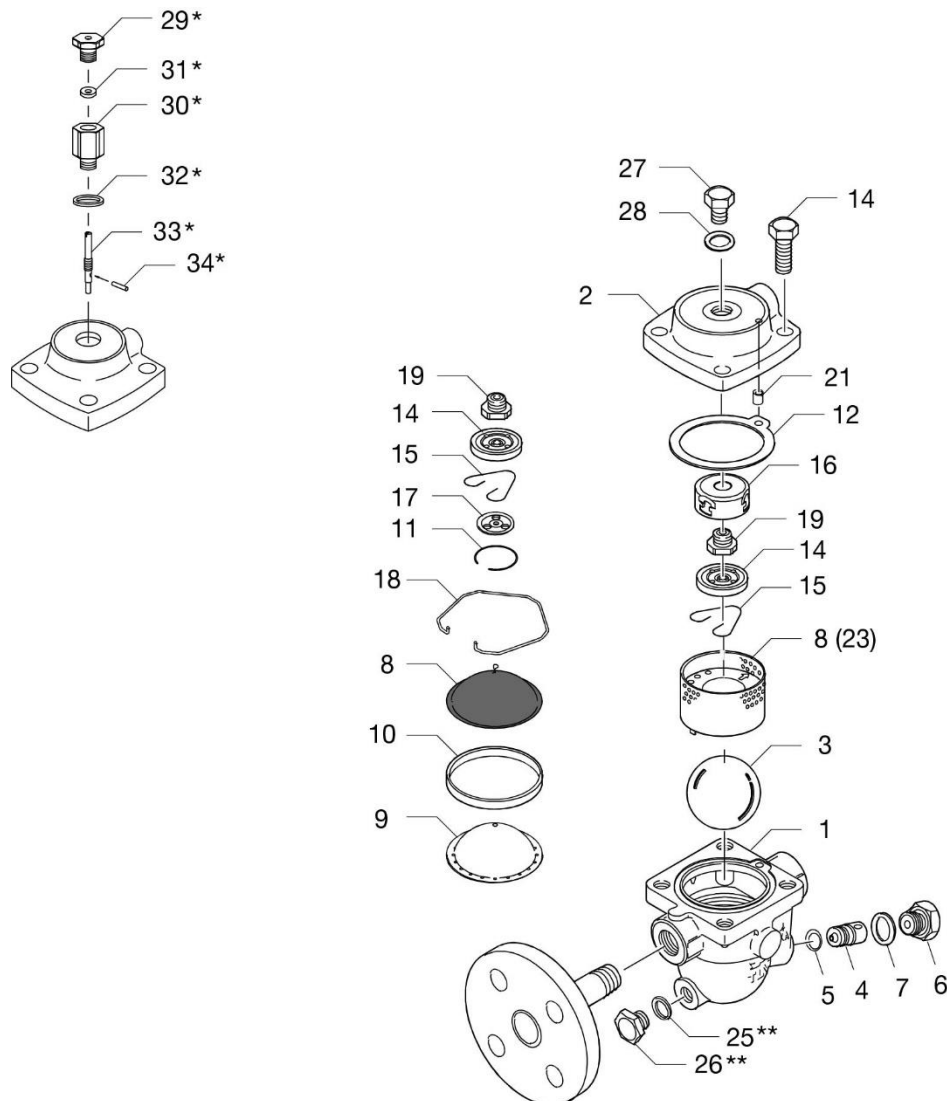



* Optional parts only available for J3X, JF3X, J5X and JF5X

** Optional for J3X, JF3X, J5X and JF5X

No.	Part Name	No.	Part Name
1	Body	18	Snap Ring
2	Cover	19	Air Vent Valve Seat
3	Float	20	Plug/Drain Plug
4	Orifice	21	Connector
5	Orifice O-ring	22	Nameplate
6	Orifice Holder Plug	23	Float Cover
7	Orifice Plug Gasket	24	X-element Guide
8	Screen	25	Drain Plug Gasket
9	Screen Holder	26	Drain Plug
10	Screen Holder Retainer	27	Plug
11	Snap Ring	28	Plug Gasket
12	Cover Gasket	29	Gland Retainer Nut
13	Cover Bolt	30	Gland Case
14	X-element	31	Gland Packing
15	Spring Clip	32	Gasket
16	X-element Guide	33	Element Retainer
17	X-element Cover	34	Spring Pin

Troubleshooting

 WARNING	NEVER apply direct heat to the float. The float may explode due to increased internal pressure, causing accidents leading to serious injury or damage to property and equipment.
 CAUTION	When disassembling or removing the product, wait until the internal pressure equals atmospheric pressure and the surface of the product has cooled to room temperature. Disassembling or removing the product when it is hot or under pressure may lead to discharge of fluids, causing burns, other injuries or damage.

If the product fails to operate properly, use the following table to locate the cause and remedy.

Problem	Cause	Remedy
No condensate is discharged (blocked) or discharge is poor	The float is damaged or filled with condensate	Replace with a new float
	The orifice opening, screen or piping are clogged with rust and scale	Clean parts
	The X-element is scratched or damaged	Replace with a new X-element
	The product operating pressure exceeds the maximum specified pressure or there is insufficient pressure differential between the product inlet and outlet	Compare specifications and actual operating conditions
	Steam locking has occurred	Perform a bypass blowdown or close the trap inlet valve and allow the trap to cool
Steam is discharged or leaks from the outlet (blowing) (steam leakage)	Build-up on the seating surface of the orifice or rust and scale build-up beneath the float	Clean parts
	Damage to the orifice	Replace with a new orifice
	The float is misshapen or has surface build-up	Clean or replace with a new float
	Improper installation orientation	Correct the installation
	Trap vibration	Lengthen the inlet piping and fasten it securely
	The air vent valve seating area of the X-element and/or air vent valve seat have surface build-up or are damaged	Clean the air vent valve seating area of the X-element and/or air vent valve seat or replace with new X-element and/or air vent valve seat
	The element retainer on the optional lock release valve is in the lowered position (the lock release valve is open)	Raise the element retainer (close the lock release valve)
Steam is leaking from a place other than the outlet	Gasket deterioration or damage	Replace with new gasket(s)
	Improper tightening torques were used	Tighten to the proper torque
	Erosion of the body or the cover	Replace with a new product
Float frequently becomes damaged	Water hammer has occurred	Study and correct the piping

NOTE: When replacing parts with new, use the parts list for reference and replace with parts from the Maintenance Kit, Repair Kit, etc. (Please note that replacement parts are only available in pre-packaged kits.)

TLV EXPRESS LIMITED WARRANTY

Subject to the limitations set forth below, TLV CO., LTD., a Japanese corporation (“**TLV**”), warrants that products which are sold by it, TLV International Inc. (“**TII**”) or one of its group companies excluding TLV Corporation (a corporation of the United States of America), (hereinafter the “**Products**”) are designed and manufactured by TLV, conform to the specifications published by TLV for the corresponding part numbers (the “**Specifications**”) and are free from defective workmanship and materials. The party from whom the Products were purchased shall be known hereinafter as the “**Seller**”. With regard to products or components manufactured by unrelated third parties (the “**Components**”), TLV provides no warranty other than the warranty from the third party manufacturer(s), if any.

Exceptions to Warranty

This warranty does not cover defects or failures caused by:

1. improper shipping, installation, use, handling, etc., by persons other than TLV, TII or TLV group company personnel, or service representatives authorized by TLV; or
2. dirt, scale or rust, etc.; or
3. improper disassembly and reassembly, or inadequate inspection and maintenance by persons other than TLV or TLV group company personnel, or service representatives authorized by TLV; or
4. disasters or forces of nature or Acts of God; or
5. abuse, abnormal use, accidents or any other cause beyond the control of TLV, TII or TLV group companies; or
6. improper storage, maintenance or repair; or
7. operation of the Products not in accordance with instructions issued with the Products or with accepted industry practices; or
8. use for a purpose or in a manner for which the Products were not intended; or
9. use of the Products in a manner inconsistent with the Specifications; or
10. use of the Products with Hazardous Fluids (fluids other than steam, air, water, nitrogen, carbon dioxide and inert gases (helium, neon, argon, krypton, xenon and radon)); or
11. failure to follow the instructions contained in the TLV Instruction Manual for the Product.

Duration of Warranty

This warranty is effective for a period of one (1) year after delivery of Products to the first end user. Notwithstanding the foregoing, asserting a claim under this warranty must be brought within three (3) years after the date of delivery to the initial buyer if not sold initially to the first end user.

ANY IMPLIED WARRANTIES NOT NEGATED HEREBY WHICH MAY ARISE BY OPERATION OF LAW, INCLUDING THE IMPLIED WARRANTIES OF MERCHANTABILITY AND FITNESS FOR A PARTICULAR PURPOSE AND ANY EXPRESS WARRANTIES NOT NEGATED HEREBY, ARE GIVEN SOLELY TO THE INITIAL BUYER AND ARE LIMITED IN DURATION TO ONE (1) YEAR FROM THE DATE OF SHIPMENT BY THE SELLER.

Exclusive Remedy

THE EXCLUSIVE REMEDY UNDER THIS WARRANTY, UNDER ANY EXPRESS WARRANTY OR UNDER ANY IMPLIED WARRANTIES NOT NEGATED HEREBY (INCLUDING THE IMPLIED WARRANTIES OF MERCHANTABILITY AND FITNESS FOR A PARTICULAR PURPOSE), IS **REPLACEMENT**; PROVIDED: (a) THE CLAIMED DEFECT IS REPORTED TO THE SELLER IN

WRITING WITHIN THE WARRANTY PERIOD, INCLUDING A DETAILED WRITTEN DESCRIPTION OF THE CLAIMED DEFECT AND HOW AND WHEN THE CLAIMED DEFECTIVE PRODUCT WAS USED; AND (b) THE CLAIMED DEFECTIVE PRODUCT AND A COPY OF THE PURCHASE INVOICE IS RETURNED TO THE SELLER, FREIGHT AND TRANSPORTATION COSTS PREPAID, UNDER A RETURN MATERIAL AUTHORIZATION AND TRACKING NUMBER ISSUED BY THE SELLER. ALL LABOR COSTS, SHIPPING COSTS, AND TRANSPORTATION COSTS ASSOCIATED WITH THE RETURN OR REPLACEMENT OF THE CLAIMED DEFECTIVE PRODUCT ARE SOLELY THE RESPONSIBILITY OF BUYER OR THE FIRST END USER. THE SELLER RESERVES THE RIGHT TO INSPECT ON THE FIRST END USER'S SITE ANY PRODUCTS CLAIMED TO BE DEFECTIVE BEFORE ISSUING A RETURN MATERIAL AUTHORIZATION. SHOULD SUCH INSPECTION REVEAL, IN THE SELLER'S REASONABLE DISCRETION, THAT THE CLAIMED DEFECT IS NOT COVERED BY THIS WARRANTY, THE PARTY ASSERTING THIS WARRANTY SHALL PAY THE SELLER FOR THE TIME AND EXPENSES RELATED TO SUCH ON-SITE INSPECTION.

Exclusion of Consequential and Incidental Damages

IT IS SPECIFICALLY ACKNOWLEDGED THAT THIS WARRANTY, ANY OTHER EXPRESS WARRANTY NOT NEGATED HEREBY, AND ANY IMPLIED WARRANTY NOT NEGATED HEREBY, INCLUDING THE IMPLIED WARRANTIES OF MERCHANTABILITY AND FITNESS FOR A PARTICULAR PURPOSE, DO NOT COVER, AND NEITHER TLV, TII NOR ITS TLV GROUP COMPANIES WILL IN ANY EVENT BE LIABLE FOR, INCIDENTAL OR CONSEQUENTIAL DAMAGES, INCLUDING, BUT NOT LIMITED TO LOST PROFITS, THE COST OF DISASSEMBLY AND SHIPMENT OF THE DEFECTIVE PRODUCT, INJURY TO OTHER PROPERTY, DAMAGE TO BUYER'S OR THE FIRST END USER'S PRODUCT, DAMAGE TO BUYER'S OR THE FIRST END USER'S PROCESSES, LOSS OF USE, OR OTHER COMMERCIAL LOSSES. WHERE, DUE TO OPERATION OF LAW, CONSEQUENTIAL AND INCIDENTAL DAMAGES UNDER THIS WARRANTY, UNDER ANY OTHER EXPRESS WARRANTY NOT NEGATED HEREBY OR UNDER ANY IMPLIED WARRANTY NOT NEGATED HEREBY (INCLUDING THE IMPLIED WARRANTIES OF MERCHANTABILITY AND FITNESS FOR A PARTICULAR PURPOSE) CANNOT BE EXCLUDED, SUCH DAMAGES ARE EXPRESSLY LIMITED IN AMOUNT TO THE PURCHASE PRICE OF THE DEFECTIVE PRODUCT. THIS EXCLUSION OF CONSEQUENTIAL AND INCIDENTAL DAMAGES, AND THE PROVISION OF THIS WARRANTY LIMITING REMEDIES HEREUNDER TO REPLACEMENT, ARE INDEPENDENT PROVISIONS, AND ANY DETERMINATION THAT THE LIMITATION OF REMEDIES FAILS OF ITS ESSENTIAL PURPOSE OR ANY OTHER DETERMINATION THAT EITHER OF THE ABOVE REMEDIES IS UNENFORCEABLE, SHALL NOT BE CONSTRUED TO MAKE THE OTHER PROVISIONS UNENFORCEABLE.

Exclusion of Other Warranties

THIS WARRANTY IS IN LIEU OF ALL OTHER WARRANTIES, EXPRESS OR IMPLIED, AND ALL OTHER WARRANTIES, INCLUDING BUT NOT LIMITED TO THE IMPLIED WARRANTIES OF MERCHANTABILITY AND FITNESS FOR A PARTICULAR PURPOSE, ARE EXPRESSLY DISCLAIMED.

Severability

Any provision of this warranty which is invalid, prohibited or unenforceable in any jurisdiction shall, as to such jurisdiction, be ineffective to the extent of such invalidity, prohibition or unenforceability without invalidating the remaining provisions hereof, and any such invalidity, prohibition or unenforceability in any such jurisdiction shall not invalidate or render unenforceable such provision in any other jurisdiction.

Service

For Service or Technical Assistance: Contact your TLV representative or your regional TLV office.

In Europe:

TLV EURO ENGINEERING GmbH

Daimler-Benz-Straße 16-18, 74915 Waibstadt, **Germany**

Tel: [49]-(0)7263-9150-0
Fax: [49]-(0)7263-9150-50

TLV EURO ENGINEERING UK LTD.

Units 7 & 8, Furlong Business Park, Bishops Cleeve, Gloucestershire GL52 8TW, **U.K.**

Tel: [44]-(0)1242-227223
Fax: [44]-(0)1242-223077

TLV EURO ENGINEERING FRANCE SARL

Parc d'Ariane 2, bât. C, 290 rue Ferdinand Perrier, 69800 Saint Priest, **France**

Tel: [33]-(0)4-72482222
Fax: [33]-(0)4-72482220

In North America:

TLV CORPORATION

13901 South Lakes Drive, Charlotte, NC 28273-6790, **U.S.A.**

Tel: [1]-704-597-9070
Fax: [1]-704-583-1610

In Mexico and Latin America:

TLV ENGINEERING S. A. DE C. V.

Av. Jesús del Monte 39-B-1001, Col. Hda. de las Palmas, Huixquilucan, Edo. de México, 52763, **Mexico**

Tel: [52]-55-5359-7949
Fax: [52]-55-5359-7585

In Oceania:

TLV PTY LIMITED

Unit 8, 137-145 Rooks Road, Nunawading, Victoria 3131, **Australia**

Tel: [61]-(0)3-9873 5610
Fax: [61]-(0)3-9873 5010

In East Asia:

TLV PTE LTD

36 Kaki Bukit Place, #02-01/02, **Singapore** 416214

Tel: [65]-6747 4600
Fax: [65]-6742 0345

TLV SHANGHAI CO., LTD.

5/F, Building 7, No.103 Caobao Road, Xuhui District, Shanghai, **China** 200233

Tel: [86]-(0)21-6482-8622
Fax: [86]-(0)21-6482-8623

TLV ENGINEERING SDN. BHD.

No.16, Jalan MJ14, Taman Industri Meranti Jaya, 47120 Puchong, Selangor, **Malaysia**

Tel: [60]-3-8052-2928
Fax: [60]-3-8065-2923

TLV PRIVATE LIMITED

252/94 (K-L) 17th Floor, Muang Thai-Phatra Complex Tower B, Rachadaphisek Road, Huaykwang, Bangkok 10310, **Thailand**

Tel: [66]-2-693-3799
Fax: [66]-2-693-3979

TLV INC.

#302-1 Bundang Technopark B, 723 Pangyo-ro, Bundang, Seongnam, Gyeonggi, 13511, **Korea**

Tel: [82]-(0)31-726-2105
Fax: [82]-(0)31-726-2195

In the Middle East:

TLV ENGINEERING FZCO

Building 2W, No. M002, PO Box 371684, Dubai Airport Free Zone, Dubai, **UAE**

Email: sales-me@tlv.co.jp

In Other Countries:

TLV INTERNATIONAL, INC.

881 Nagasuna, Noguchi, Kakogawa, Hyogo 675-8511, **Japan**

Tel: [81]-(0)79-427-1818
Fax: [81]-(0)79-425-1167

Manufacturer:

TLV CO., LTD.

881 Nagasuna, Noguchi, Kakogawa, Hyogo 675-8511, **Japan**

Tel: [81]-(0)79-422-1122
Fax: [81]-(0)79-422-0112

Option: Pressure-balancing Line Connection (no X-element)

Configuration

NOTE: The X-element has been removed from the cover of the standard product and a pressure-balancing line port has been prepared on the top.

Screwed Type Pressure-balancing Line (with plug)

J3X·JF3X/J5X·JF5X

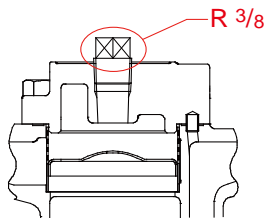

J7X/J7.5X/J8X

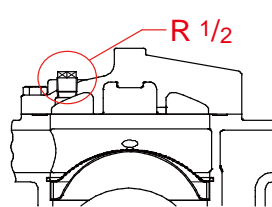

J7.2X

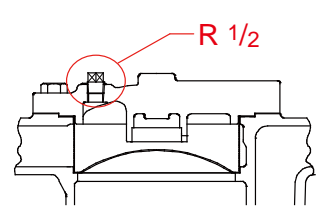

Piping Example: Flange Type Pressure-balancing Line

A screwed type flange may be installed on all models, as shown below.

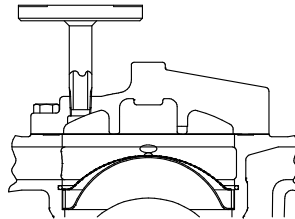

- The product is designed to continually and automatically discharge inflowing condensate. However, if condensate completely fills the trap inlet piping, displacement of steam and condensate becomes impossible. As a result, steam in the trap body will not be able to escape thus preventing condensate from entering the trap. This phenomenon is called steam locking. With a large difference between the steam and the ambient temperatures, the steam flowing into the trap will eventually condense and the steam locking phenomenon will be eliminated naturally.
- When the steam trap inlet pressure is slight or negative, the difference between the steam temperature and the ambient temperature is small. This increases the time required to condense steam, making it difficult to resolve the steam locking. To prevent steam locking, ensure steam escapes upstream so condensate can flow into the steam trap.

Install the pressure-balancing line in the following manner:

Example: Heat Exchanger

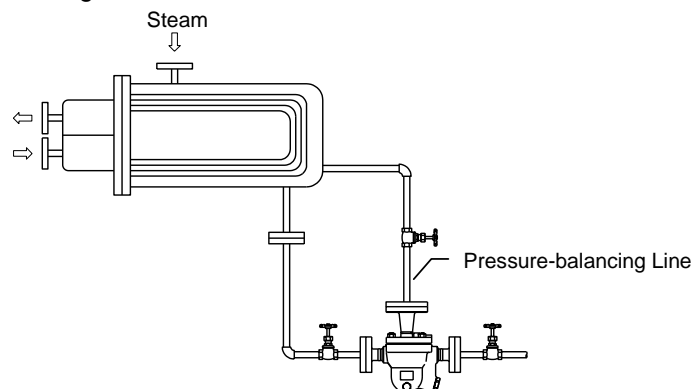

Install the pressure-balancing line to a location where steam is present in both the trap and the equipment or trap inlet piping.