



Instruction Manual

Temperature Regulating Valve TC8

Contents

Introduction	1
Safety Considerations	2
Checking the Piping	3
Specifications	4
Installation Measurements	4
Configuration	5
Installation	6
Maintenance.....	9
Disassembly/Reassembly	10
Troubleshooting	11
TLV EXPRESS LIMITED WARRANTY.....	12
Service	14

Introduction

Thank you for purchasing the TLV TC8 temperature regulating valve.

This product has been thoroughly inspected before being shipped from the factory. When the product is delivered, before doing anything else, check the specifications and external appearance to make sure nothing is out of the ordinary. Also be sure to read this manual carefully before use and follow the instructions to be sure of using the product properly.

The TC8 is a self-adjusting, temperature regulating valve with a pressure balancing mechanism. It has a wide temperature regulation range, and because it has a simple twist-action temperature adjustment ring, the TC8 is also easy to use.





For products with special order specifications or options, if detailed instructions for the special order specifications or options are not contained in this manual, please contact TLV for full details.

This instruction manual is intended for use with the model(s) listed on the front cover. It is necessary not only for installation but for subsequent maintenance, disassembly/reassembly and troubleshooting. Please keep it in a safe place for future reference.

Safety Considerations

- Read this section carefully before use and be sure to follow the instructions.
- Installation, inspection, maintenance, repairs, disassembly, adjustment and valve opening/closing should be carried out only by trained maintenance personnel.
- The precautions listed in this manual are designed to ensure safety and prevent equipment damage and personal injury. For situations that may occur as a result of erroneous handling, three different types of cautionary items are used to indicate the degree of urgency and the scale of potential damage and danger: DANGER, WARNING and CAUTION.
- The three types of cautionary items above are very important for safety: be sure to observe all of them as they relate to installation, use, maintenance, and repair. Furthermore, TLV accepts no responsibility for any accidents or damage occurring as a result of failure to observe these precautions.

Symbols

	Indicates a DANGER, WARNING or CAUTION item.
	Indicates an urgent situation which poses a threat of death or serious injury
	Indicates that there is a potential threat of death or serious injury
	Indicates that there is a possibility of injury or equipment/product damage
	<p>Install properly and DO NOT use this product outside the recommended operating pressure, temperature and other specification ranges. Improper use may result in such hazards as damage to the product or malfunctions that may lead to serious accidents. Local regulations may restrict the use of this product to below the conditions quoted.</p> <p>Take measures to prevent people from coming into direct contact with product outlets. Failure to do so may result in burns or other injury from the discharge of fluids.</p> <p>When disassembling or removing the product, wait until the internal pressure equals atmospheric pressure and the surface of the product has cooled to room temperature. Disassembling or removing the product when it is hot or under pressure may lead to discharge of fluids, causing burns, other injuries or damage.</p>

Continued on the next page

 CAUTION	Be sure to use only the recommended components when repairing the product, and NEVER attempt to modify the product in any way. Failure to observe these precautions may result in damage to the product and burns or other injury due to malfunction or the discharge of fluids.
	Do not use excessive force when connecting threaded pipes to the product. Over-tightening may cause breakage leading to fluid discharge, which may cause burns or other injury.
	Use only under conditions in which no freeze-up will occur. Freezing may damage the product, leading to fluid discharge, which may cause burns or other injury.
	Use only under conditions in which no water hammer will occur. The impact of water hammer may damage the product, leading to fluid discharge, which may cause burns or other injury.

Checking the Piping



Use only under conditions in which no water hammer will occur. The impact of water hammer may damage the product, leading to fluid discharge, which may cause burns or other injury.

Check to make sure that the pipes to be connected to the product have been installed properly.

1. Is the pipe diameter suitable?
2. Has the piping been blown out and any scale or dirt been removed prior to installation?
3. Has sufficient space been secured for maintenance work to be carried out?
4. Have maintenance valves been installed at the inlet and outlet?
5. Has a strainer been installed at the inlet?
6. Has a bypass valve been installed?

Specifications



Install properly and **DO NOT** use this product outside the recommended operating pressure, temperature and other specification ranges. Improper use may result in such hazards as damage to the product or malfunctions which may lead to serious accidents. Local regulations may restrict the use of this product to below the conditions quoted.



Use only under conditions in which no freeze-up will occur. Freezing may damage the product, leading to fluid discharge, which may cause burns or other injury.

Refer to the product nameplate for detailed specifications.

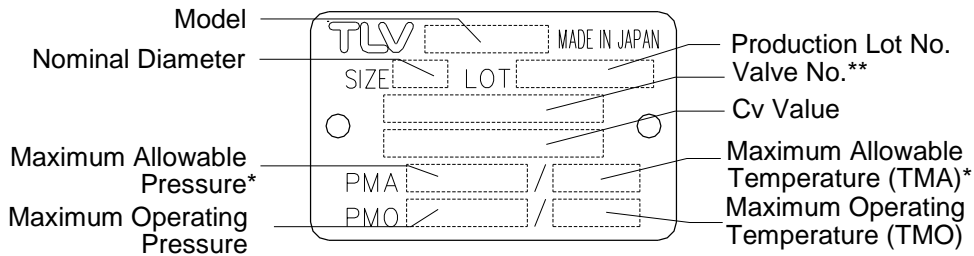

* Maximum allowable pressure (PMA) and maximum allowable temperature (TMA) are **PRESSURE SHELL DESIGN CONDITIONS, NOT OPERATING CONDITIONS.**

** Valve No. is displayed for products with options. This item is omitted from the nameplate when there are no options.

Installation Measurements

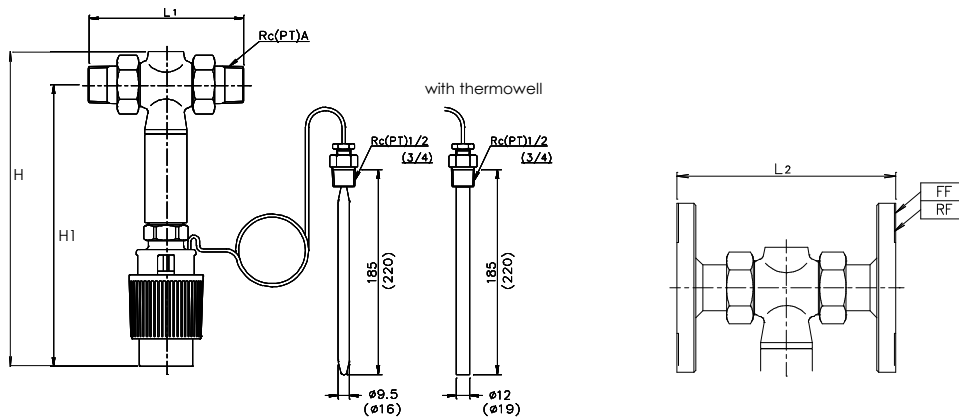

Nominal Diameter	15 mm	20 mm	25 mm	32 mm	40 mm	50 mm
A	1/2"	3/4"	1"	1 1/4"	1 1/2"	2"
L ₁	129 mm	144 mm	159 mm	180 mm	196 mm	228 mm
L ₂	150 mm	170 mm	180 mm	200 mm	220 mm	250 mm
H	287 mm			355 mm		
H ₁	257 mm			300 mm		

Configuration

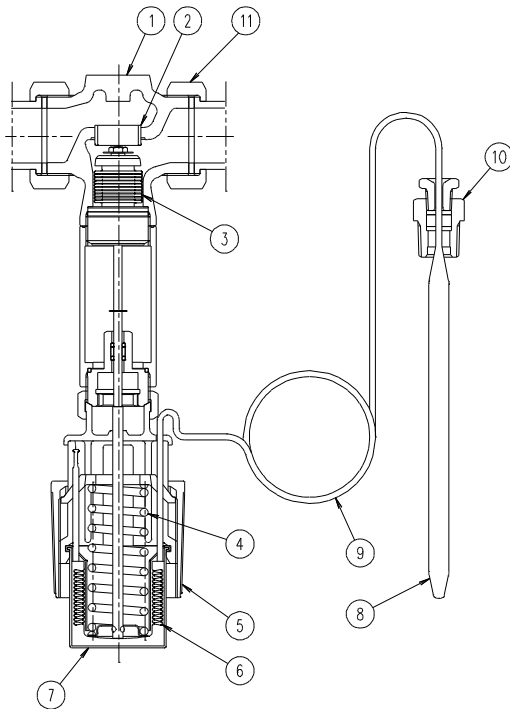

No.	Name
1	Valve body
2	Valve seat
3	Main valve unit
4	Spring
5	Set point adjustment ring
6	Positioning bellows
7	Temperature regulator
8	Temperature sensor
9	Capillary tube
10	Sensor connecting nut
11	Union nut

The temperature regulating valve is made up of two main parts, the body of the valve and the temperature regulating thermostat, which are connected by a union nut.

Operating Principles

The temperature of the medium produces a pressure in the sensor (8) which is proportional to the actual temperature measured. This pressure is transmitted through the capillary tube (9) to the operating element in the temperature regulator where it is converted into a positioning force. This force acts on the positioning bellows (6) and the pin of the operating element, which in turn moves the main valve plug stem (not labelled in this diagram). Therefore, as the temperature rises, the valve begins to close, and conversely, as the temperature falls the valve opens.

By turning the set point adjustment ring (5) the point of response of the regulator is changed by the spring (4). Consequently the valve plug moves through its full travel range within a higher or lower temperature range measured by the sensor.

Installation



Install properly and **DO NOT** use this product outside the recommended operating pressure, temperature and other specification ranges. Improper use may result in such hazards as damage to the product or malfunctions which may lead to serious accidents. Local regulations may restrict the use of this product to below the conditions quoted.



Take measures to prevent people from coming into direct contact with product outlets. Failure to do so may result in burns or other injury from the discharge of fluids.

Installation, inspection, maintenance, repairs, disassembly, adjustment and valve opening/closing should be carried out only by trained maintenance personnel.

The following is an outline of the basic installation procedure.

1. Assemble the valve body and regulating thermostat
2. Install the product on the piping
3. Install the temperature sensor

These steps are covered in more detail below:

(1) ASSEMBLING THE VALVE BODY AND THE REGULATING THERMOSTAT

- a) First take the valve body and the regulating thermostat.
- b) The valve and the regulating thermostat should be installed so that:
 - (1) the arrow on the valve body points in the direction of flow of the medium, and
 - (2) the capillary tube travels in the direction of the control thermostat.
- c) Use a 36 mm open-ended torque wrench to tighten the union nut to roughly 40 N·m torque (400 kg·cm), so that the valve and the thermostat no longer move. If the union is not sufficiently tight, the product may not function properly.

(2) PIPING

- a) This product must be installed only on horizontal pipes
- b) Before installing the product on the piping, be sure to blow out the pipes first to get rid of any dirt or scraps inside. This is even more important when installing the product on new pipes or on pipes which have not been used for some time.
- c) Install a strainer on the pipe before the product inlet. This is to prevent things like dirt or welding scraps getting into the product and causing damage to parts of the valve such as the valve seat. The strainer should be fitted so that the screen is horizontal, following both the direction of flow of the medium and the arrow on the valve body, and with enough space for the screen to be removed when necessary.
- d) Stop valves should be installed at the product inlet and outlet to allow the flow of the medium to be stopped when necessary and to allow maintenance checks to be carried out.
- e) Remove the union nuts from the product and connect them to the pipe (for flange valves, flanges must be welded to the pipe).
- f) The medium must flow through the valve in the direction indicated by the arrow on the valve body. The control thermostat must hang down vertically from the valve body.

- g) Insert the union nut gaskets, attach the product to the pipe and tighten the union nuts. Care should be taken not to exert pressure on the pipe after connecting the product, as this may cause leakages from the union nuts.

(3) INSTALL TEMPERATURE SENSOR

- a) The temperature control sensor can be installed practically anywhere. However, care should be taken to choose a place in which the sensor will be fully immersed in the medium. The sensor will not perform properly if it is installed in a place where it is likely to overheat (i.e., near a heat source), or where it will be idle for considerable periods due to the lack of flow of the medium.
- b) A 15 mm female threaded socket (for nominal diameters 15 to 25 mm) or a 20 mm female threaded socket (for nominal diameters 32 to 50 mm) should be welded to the pipe wherever the sensor is to be installed.
The screw thread of the sensor connecting nut should be wound with sealing tape and attached before inserting the sensor into the socket. Finally, the sensor should then be secured with the clamping screw.

CAUTION

- DO NOT try to detach the temperature sensor from the temperature regulator.
- Capillary tubes should be positioned where they will not get damaged easily and where the ambient temperature is even. Capillary tube should NOT be allowed to come into contact with things such as steam pipes or any other hot surfaces.
- Capillary tubes should never be cut, and should always be handled carefully. Any excess tubing should be coiled up. In cases where capillary tubes need to be bent or coiled, the smallest permissible bending radius is 50 mm.
- Care should be taken when installing the temperature sensor, as only similar types of materials can be combined. For example, if a non-ferrous temperature sensor is installed in a stainless steel tank, electrolytic corrosion is likely to occur, so it will be necessary to use a stainless steel thermowell to protect it.
- A thermometer should be fitted close to the temperature sensor to ensure that the temperature settings are correct and that the product is functioning properly.
- The temperature around the product should never be allowed to exceed 80 °C.

TEMPERATURE REGULATION

Turn the adjustment ring and use the scale markings to adjust the temperature. There are *plus* (+) and *minus* (-) symbols printed on the cover to indicate how to lower and raise the temperature: turning the adjustment ring towards the *plus* symbol will raise the temperature, whilst turning the ring towards the *minus* symbol will lower the temperature.

A thermometer should be fixed near to the temperature sensor in order to fine-tune the set point temperature.

Correlation between scale markings and set temperature

Set Point Range (°C)	Set Point Change Per Revolution	Sensor Diameter (mm)
0 to 35	2.5	9.5
	2	16
25 to 70	3	9.5
	2	16
40 to 100	4	9.5
	3	16
50 to 120	4	9.5
	4.5	16
70 to 150	4.5	9.5
	5	16

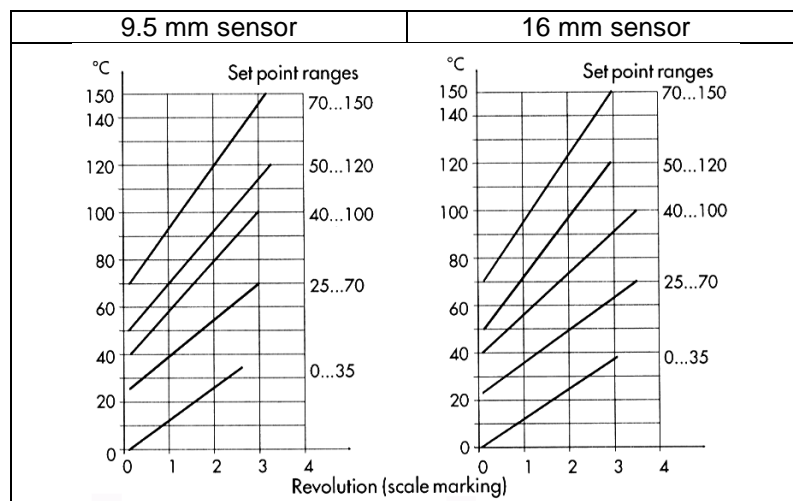

Maintenance



Take measures to prevent people from coming into direct contact with product outlets. Failure to do so may result in burns or other injury from the discharge of fluids.



Be sure to use only the recommended components when repairing the product, and NEVER attempt to modify the product in any way. Failure to observe these precautions may result in damage to the product or burns or other injury due to malfunction or the discharge of fluids.

Operation check

If this product gets damaged in any way, it may be less efficient, and as a result there may be a reduction in product quality and in productivity.

Periodically (at least biannually) the operation should also be checked by using diagnostic equipment such as a stethoscope or thermometer.

Normal	<p>OPEN VALVE: when the temperature falls below the set point, steam flows</p> <p>CLOSED VALVE: when the temperature reaches the set point, the steam supply stops</p>
Blocked (Discharge Impossible)	Although the set point temperature has been reached, the valve does not close completely, and steam leaks from the valve seat. Depending on the degree of leakage, there may be a slight, but continuous flow noise. (The temperature gradually rises above the set point temperature).
Blowing	Although the set point temperature has been reached, the valve does not close, and steam continues to flow. A loud, continuous flow noise can be heard. (Temperature considerably in excess of the set point temperature.)

Disassembly/Reassembly

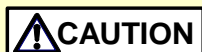

When disassembling or removing the product, wait until the internal pressure equals atmospheric pressure and the surface of the product has cooled to room temperature. Disassembling or removing the product when it is hot or under pressure may lead to discharge of fluids, causing burns, other injuries or damage.

Use the following procedures to remove components. Use the same procedures in reverse to reassemble.

(Installation, inspection, maintenance, repairs, disassembly, adjustment and valve opening/closing should be carried out only by trained maintenance personnel.)

Disassembly and Reassembly of Components

Part	Disassembly	Reassembly
Regulating thermostat	A spanner should be used to loosen the union nut attached to the regulating thermostat and remove it from the valve body.	The nut should be screwed on by hand and tightened with a spanner. (Tightening torque: 30 N·m)
Insulation pipe	Use a pipe wrench to remove the insulation pipe from the valve body. The wrench should only be necessary to loosen the pipe, after which it should be possible to unscrew it by hand.	A fluorine resin gasket should be inserted into the groove around the end of the insulation pipe to stop leakage. The pipe should then be screwed on by hand and tightened with a pipe wrench.
Main valve unit	A 19 mm hexagonal jig* should be used to unscrew the main valve unit. The valve and the screw-fitting can then be removed together as a single unit.	The valve unit should be screwed on by hand and tightened using a 19 mm hexagonal jig*.

* can be ordered separately from TLV

Exploded View

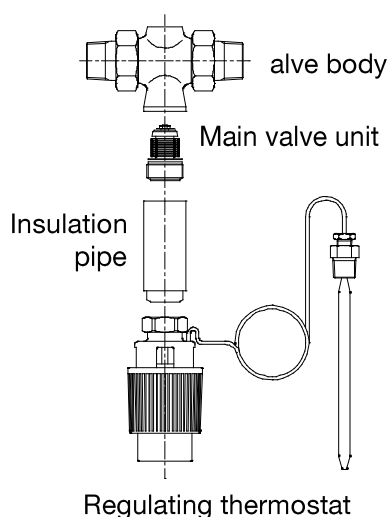

Troubleshooting



When disassembling or removing the product, wait until the internal pressure equals atmospheric pressure and the surface of the product has cooled to room temperature. Disassembling or removing the product when it is hot or under pressure may lead to discharge of fluids, causing burns, other injuries or damage.

This product is shipped after stringent checks and inspection, and should perform its intended function for a long period of time without failure. However, should there be any problems encountered in the operation of the product, consult the troubleshooting guide below.

Problem	Cause	Inspection area	Remedy
The temperature rises above the set point	the seal is clogged with dirt/scale	valve, valve seat	clean the valve or the valve seat
	the seal is worn	valve, valve seat	replace the valve body or the main valve unit
	the thermostat is damaged	temperature sensor, capillary tube, temperature adjustment ring	replace the temperature regulation thermostat
The temperature does not reach the set point	the inlet valve is closed	inlet valve	open the inlet valve
	the strainer is clogged with dirt	strainer screen	clean the screen

TLV EXPRESS LIMITED WARRANTY

Subject to the limitations set forth below, TLV CO., LTD., a Japanese corporation (“**TLV**”), warrants that products which are sold by it, TLV International Inc. (“**TII**”) or one of its group companies excluding TLV Corporation (a corporation of the United States of America), (hereinafter the “**Products**”) are designed and manufactured by TLV, conform to the specifications published by TLV for the corresponding part numbers (the “**Specifications**”) and are free from defective workmanship and materials. The party from whom the Products were purchased shall be known hereinafter as the “**Seller**”. With regard to products or components manufactured by unrelated third parties (the “**Components**”), TLV provides no warranty other than the warranty from the third party manufacturer(s), if any.

Exceptions to Warranty

This warranty does not cover defects or failures caused by:

1. improper shipping, installation, use, handling, etc., by persons other than TLV, TII or TLV group company personnel, or service representatives authorized by TLV; or
2. dirt, scale or rust, etc.; or
3. improper disassembly and reassembly, or inadequate inspection and maintenance by persons other than TLV or TLV group company personnel, or service representatives authorized by TLV; or
4. disasters or forces of nature or Acts of God; or
5. abuse, abnormal use, accidents or any other cause beyond the control of TLV, TII or TLV group companies; or
6. improper storage, maintenance or repair; or
7. operation of the Products not in accordance with instructions issued with the Products or with accepted industry practices; or
8. use for a purpose or in a manner for which the Products were not intended; or
9. use of the Products in a manner inconsistent with the Specifications; or
10. use of the Products with Hazardous Fluids (fluids other than steam, air, water, nitrogen, carbon dioxide and inert gases (helium, neon, argon, krypton, xenon and radon)); or
11. failure to follow the instructions contained in the TLV Instruction Manual for the Product.

Duration of Warranty

This warranty is effective for a period of one (1) year after delivery of Products to the first end user. Notwithstanding the foregoing, asserting a claim under this warranty must be brought within three (3) years after the date of delivery to the initial buyer if not sold initially to the first end user.

ANY IMPLIED WARRANTIES NOT NEGATED HEREBY WHICH MAY ARISE BY OPERATION OF LAW, INCLUDING THE IMPLIED WARRANTIES OF MERCHANTABILITY AND FITNESS FOR A PARTICULAR PURPOSE AND ANY EXPRESS WARRANTIES NOT NEGATED HEREBY, ARE GIVEN SOLELY TO THE INITIAL BUYER AND ARE LIMITED IN DURATION TO ONE (1) YEAR FROM THE DATE OF SHIPMENT BY THE SELLER.

Exclusive Remedy

THE EXCLUSIVE REMEDY UNDER THIS WARRANTY, UNDER ANY EXPRESS WARRANTY OR UNDER ANY IMPLIED WARRANTIES NOT NEGATED HEREBY (INCLUDING THE IMPLIED WARRANTIES OF MERCHANTABILITY AND FITNESS FOR A PARTICULAR PURPOSE), IS **REPLACEMENT**; PROVIDED: (a) THE CLAIMED DEFECT IS REPORTED TO THE SELLER IN WRITING WITHIN THE WARRANTY PERIOD, INCLUDING A DETAILED WRITTEN DESCRIPTION OF THE CLAIMED

DEFECT AND HOW AND WHEN THE CLAIMED DEFECTIVE PRODUCT WAS USED; AND (b) THE CLAIMED DEFECTIVE PRODUCT AND A COPY OF THE PURCHASE INVOICE IS RETURNED TO THE SELLER, FREIGHT AND TRANSPORTATION COSTS PREPAID, UNDER A RETURN MATERIAL AUTHORIZATION AND TRACKING NUMBER ISSUED BY THE SELLER. ALL LABOR COSTS, SHIPPING COSTS, AND TRANSPORTATION COSTS ASSOCIATED WITH THE RETURN OR REPLACEMENT OF THE CLAIMED DEFECTIVE PRODUCT ARE SOLELY THE RESPONSIBILITY OF BUYER OR THE FIRST END USER. THE SELLER RESERVES THE RIGHT TO INSPECT ON THE FIRST END USER'S SITE ANY PRODUCTS CLAIMED TO BE DEFECTIVE BEFORE ISSUING A RETURN MATERIAL AUTHORIZATION. SHOULD SUCH INSPECTION REVEAL, IN THE SELLER'S REASONABLE DISCRETION, THAT THE CLAIMED DEFECT IS NOT COVERED BY THIS WARRANTY, THE PARTY ASSERTING THIS WARRANTY SHALL PAY THE SELLER FOR THE TIME AND EXPENSES RELATED TO SUCH ON-SITE INSPECTION.

Exclusion of Consequential and Incidental Damages

IT IS SPECIFICALLY ACKNOWLEDGED THAT THIS WARRANTY, ANY OTHER EXPRESS WARRANTY NOT NEGATED HEREBY, AND ANY IMPLIED WARRANTY NOT NEGATED HEREBY, INCLUDING THE IMPLIED WARRANTIES OF MERCHANTABILITY AND FITNESS FOR A PARTICULAR PURPOSE, DO NOT COVER, AND NEITHER TLV, TII NOR ITS TLV GROUP COMPANIES WILL IN ANY EVENT BE LIABLE FOR, INCIDENTAL OR CONSEQUENTIAL DAMAGES, INCLUDING, BUT NOT LIMITED TO LOST PROFITS, THE COST OF DISASSEMBLY AND SHIPMENT OF THE DEFECTIVE PRODUCT, INJURY TO OTHER PROPERTY, DAMAGE TO BUYER'S OR THE FIRST END USER'S PRODUCT, DAMAGE TO BUYER'S OR THE FIRST END USER'S PROCESSES, LOSS OF USE, OR OTHER COMMERCIAL LOSSES. WHERE, DUE TO OPERATION OF LAW, CONSEQUENTIAL AND INCIDENTAL DAMAGES UNDER THIS WARRANTY, UNDER ANY OTHER EXPRESS WARRANTY NOT NEGATED HEREBY OR UNDER ANY IMPLIED WARRANTY NOT NEGATED HEREBY (INCLUDING THE IMPLIED WARRANTIES OF MERCHANTABILITY AND FITNESS FOR A PARTICULAR PURPOSE) CANNOT BE EXCLUDED, SUCH DAMAGES ARE EXPRESSLY LIMITED IN AMOUNT TO THE PURCHASE PRICE OF THE DEFECTIVE PRODUCT. THIS EXCLUSION OF CONSEQUENTIAL AND INCIDENTAL DAMAGES, AND THE PROVISION OF THIS WARRANTY LIMITING REMEDIES HEREUNDER TO REPLACEMENT, ARE INDEPENDENT PROVISIONS, AND ANY DETERMINATION THAT THE LIMITATION OF REMEDIES FAILS OF ITS ESSENTIAL PURPOSE OR ANY OTHER DETERMINATION THAT EITHER OF THE ABOVE REMEDIES IS UNENFORCEABLE, SHALL NOT BE CONSTRUED TO MAKE THE OTHER PROVISIONS UNENFORCEABLE.

Exclusion of Other Warranties

THIS WARRANTY IS IN LIEU OF ALL OTHER WARRANTIES, EXPRESS OR IMPLIED, AND ALL OTHER WARRANTIES, INCLUDING BUT NOT LIMITED TO THE IMPLIED WARRANTIES OF MERCHANTABILITY AND FITNESS FOR A PARTICULAR PURPOSE, ARE EXPRESSLY DISCLAIMED.

Severability

Any provision of this warranty which is invalid, prohibited or unenforceable in any jurisdiction shall, as to such jurisdiction, be ineffective to the extent of such invalidity, prohibition or unenforceability without invalidating the remaining provisions hereof, and any such invalidity, prohibition or unenforceability in any such jurisdiction shall not invalidate or render unenforceable such provision in any other jurisdiction.

Service

For Service or Technical Assistance: Contact your TLV representative or your regional TLV office.

In Europe:

TLV EURO ENGINEERING GmbH

Daimler-Benz-Straße 16-18, 74915 Waibstadt, **Germany**

Tel: [49]-(0)7263-9150-0
Fax: [49]-(0)7263-9150-50

TLV EURO ENGINEERING UK LTD.

Units 7 & 8, Furlong Business Park, Bishops Cleeve, Gloucestershire GL52 8TW, **U.K.**

Tel: [44]-(0)1242-227223
Fax: [44]-(0)1242-223077

TLV EURO ENGINEERING FRANCE SARL

Parc d'Ariane 2, bât. C, 290 rue Ferdinand Perrier, 69800 Saint Priest, **France**

Tel: [33]-(0)4-72482222
Fax: [33]-(0)4-72482220

In North America:

TLV CORPORATION

13901 South Lakes Drive, Charlotte, NC 28273-6790, **U.S.A.**

Tel: [1]-704-597-9070
Fax: [1]-704-583-1610

In Mexico and Latin America:

TLV ENGINEERING S. A. DE C.V.

Av. Jesús del Monte 39-B-1001, Col. Hda. de las Palmas, Huixquilucan, Edo. de México, 52763, **Mexico**

Tel: [52]-55-5359-7949
Fax: [52]-55-5359-7585

In Oceania:

TLV PTY LIMITED

Unit 8, 137-145 Rooks Road, Nunawading, Victoria 3131, **Australia**

Tel: [61]-(0)3-9873 5610
Fax: [61]-(0)3-9873 5010

In East Asia:

TLV PTE LTD

36 Kaki Bukit Place, #02-01/02, **Singapore** 416214

Tel: [65]-6747 4600
Fax: [65]-6742 0345

TLV SHANGHAI CO., LTD.

Room 5406, No. 103 Cao Bao Road, Shanghai, **China** 200233

Tel: [86]-(0)21-6482-8622
Fax: [86]-(0)21-6482-8623

TLV ENGINEERING SDN. BHD.

No.16, Jalan MJ14, Taman Industri Meranti Jaya, 47120 Puchong, Selangor, **Malaysia**

Tel: [60]-3-8065-2928
Fax: [60]-3-8065-2923

TLV PRIVATE LIMITED

252/94 (K-L) 17th Floor, Muang Thai-Phatra Complex Tower B, Rachadaphisek Road, Huaykwang, Bangkok 10310, **Thailand**

Tel: [66]-2-693-3799
Fax: [66]-2-693-3979

TLV INC.

#302-1 Bundang Technopark B, 723 Pangyo-ro, Bundang, Seongnam, Gyeonggi, 13511, **Korea**

Tel: [82]-(0)31-726-2105
Fax: [82]-(0)31-726-2195

In the Middle East:

TLV ENGINEERING FZCO

Building 2W, No. M002, PO Box 371684, Dubai Airport Free Zone, Dubai, **UAE**

Email: sales-me@tlv.co.jp

In Other Countries:

TLV INTERNATIONAL, INC.

881 Nagasuna, Noguchi, Kakogawa, Hyogo 675-8511, **Japan**

Tel: [81]-(0)79-427-1818
Fax: [81]-(0)79-425-1167

Manufacturer:

TLV CO., LTD.

881 Nagasuna, Noguchi, Kakogawa, Hyogo 675-8511, **Japan**

Tel: [81]-(0)79-422-1122
Fax: [81]-(0)79-422-0112