



Instruction Manual

High-precision Multi-control Valve for Steam

COSPECT

MC-COS-3/MC-COS-16

Actuator: MC-GA2

Contents

Introduction	1
Safety Considerations	2
Specifications	4
Correct Usage of the MC-COS Multi-control Valve	6
Configuration	8
Installation	10
Wiring	15
Setting the Valve Coefficient	17
Operation	18
In the Event of a Power Outage/Restoration.....	19
Inspection and Maintenance	20
Disassembly	21
Reassembly	26
Troubleshooting	27
TLV EXPRESS LIMITED WARRANTY.....	33
Service	35

Introduction

Thank you for purchasing the TLV MC-COS high-precision multi-control valve for steam.

This product has been thoroughly inspected before being shipped from the factory. When the product is delivered, before doing anything else, check the specifications and external appearance to make sure nothing is out of the ordinary. Also be sure to read this manual carefully before use and follow the instructions to be sure of using the product properly.

The TLV high-precision multi-control valve, model MC-COS, provides accurate pressure control (MC-COS-3, MC-COS-16) and temperature control (MC-COS-16) when combined with the TLV SC-F70 digital indicator controller or the SP-F70 programmable indicator controller.





If detailed instructions for special order specifications or options not contained in this manual are required, please contact TLV for full details.



This instruction manual is intended for use with the model(s) listed on the front cover. It is needed not only for installation, but also for subsequent maintenance, disassembly/reassembly and troubleshooting. Please keep it in a safe place for future reference.

Safety Considerations

- Read this section carefully before use and be sure to follow the instructions.
- Installation, inspection, maintenance, repairs, disassembly, adjustment and valve opening/closing should be carried out only by trained maintenance personnel.
- The precautions listed in this manual are designed to ensure safety and prevent equipment damage and personal injury. For situations that may occur as a result of erroneous handling, three different types of cautionary items are used to indicate the degree of urgency and the scale of potential damage and danger: DANGER, WARNING and CAUTION.
- The three types of cautionary items above are very important for safety: be sure to observe all of them as they relate to installation, use, maintenance and repair. Furthermore, TLV accepts no responsibility for any accidents or damage occurring as a result of failure to observe these precautions.

Symbols

	Indicates a DANGER, WARNING or CAUTION item.
	Indicates an urgent situation which poses a threat of death or serious injury
	Indicates that there is a potential threat of death or serious injury
	Indicates that there is a possibility of injury or equipment / product damage

	NEVER apply direct heat to the float. The float may explode due to increased internal pressure, causing accidents leading to serious injury or damage to property and equipment.
	Install properly and DO NOT use this product outside the recommended operating pressure, temperature and other specification ranges. Improper use may result in such hazards as damage to the product or malfunctions that may lead to serious accidents. Local regulations may restrict the use of this product to below the conditions quoted.
	DO NOT use the product in excess of the maximum operating pressure differential. Such use could make discharge through the steam trap impossible (blocked).
	Use hoisting equipment for heavy objects (weighing approximately 20 kg (44 lb) or more). Failure to do so may result in back strain or other injury if the object should fall.
	Take measures to prevent people from coming into direct contact with product outlets. Failure to do so may result in burns or other injury from the discharge of fluids.

Continued on the next page

 CAUTION	<p>When disassembling or removing the product, wait until the internal pressure equals atmospheric pressure and the surface of the product has cooled to room temperature. Disassembling or removing the product when it is hot or under pressure may lead to discharge of fluids, causing burns, other injuries or damage.</p>
	<p>Be sure to use only the recommended components when repairing the product, and NEVER attempt to modify the product in any way. Failure to observe these precautions may result in damage to the product and burns or other injury due to malfunction or the discharge of fluids.</p>
	<p>Do not use excessive force when connecting threaded pipes to the product. Over-tightening may cause breakage leading to fluid discharge, which may cause burns or other injury.</p>
	<p>Use only under conditions in which no freeze-up will occur. Freezing may damage the product, leading to fluid discharge, which may cause burns or other injury.</p>
	<p>Use only under conditions in which no water hammer will occur. The impact of water hammer may damage the product, leading to fluid discharge, which may cause burns or other injury.</p>
	<p>Make sure the power supply is OFF before carrying out work on the wiring or inspections involving disassembly. If such work is carried out with the power on, there is a danger that equipment may malfunction or electric shock may occur, leading to injury or other accidents.</p>
	<p>Make sure that wiring work requiring a special license is carried out by qualified personnel. If carried out by unqualified personnel, overheating or short circuits leading to injury, fires, damage or other accidents may occur.</p>
	<p>When using this product, NEVER stand close to, or leave tools anywhere near moving parts, such as the shaft. Contact with moving parts or objects becoming caught in moving parts could lead to injury or damage or other accidents.</p>

Specifications



Install properly and **DO NOT** use this product outside the recommended operating pressure, temperature and other specification ranges. Improper use may result in such hazards as damage to the product or malfunctions which may lead to serious accidents. Local regulations may restrict the use of this product to below the conditions quoted.



DO NOT use the product in excess of the maximum operating pressure differential; such use could make discharge impossible (blocked).



Use only under conditions in which no freeze-up will occur. Freezing may damage the product, leading to fluid discharge, which may cause burns or other injury.

Refer to the product nameplate for detailed specifications.

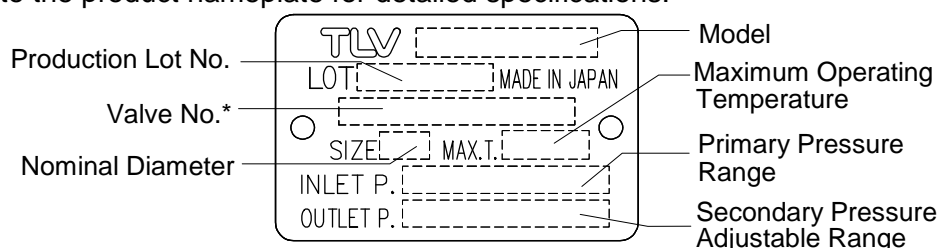

* Valve No. is displayed for products with options. This item is omitted from the nameplate when there are no options.

Actuator Specifications

	Actuator Model	MC-GA2
Power Source	Power Source Voltage	Free between 100 and 240 V AC (50/60 Hz)
	Power Consumption	With motor running: 75 VA max.
	Insulation Resistance	500 V DC, 100 M Ω min. between the power source terminal and ground terminal
	Withstand Voltage	Between the power source terminal and ground terminal: 1800 V AC, 1 second
Operation	Drive System	Positional control by DC brushless motor
	Operation Input (Valve Opening)	4 – 20 mA DC (input impedance: approx. 250 Ω)
	Emergency Action	Valve fully closed by an operation signal interruption. When input power is cut off: held at position just before power was cut off
	Time Rating	Continuous
	Thermal Protection	Built-in overcurrent protection circuit
	Time Required to Fully Open/Close	Fully closed \leftrightarrow fully open: Approx. 15 seconds
	Manual Operation	Possible with the power OFF
Environment	Allowable Ambient Temperature Range	0 to 50 $^{\circ}$ C (32 to 122 $^{\circ}$ F)
	Allowable Ambient Humidity	10% to 90% RH (without dew)
	Allowable altitude	2000 m (6600 ft) max.
	Vibration Resistance	0.5 G max.
	Water Resistance	Rain resistant (equivalent to IP54)
	Material	Motor cover: Aluminum casting Main mounting plate: cast iron

CV Value

Size	(mm)	15	20	25	32	40	50	65	80	100
	(in)	(1/2)	(3/4)	(1)	(1 1/4)	(1 1/2)	(2)	(2 1/2)	(3)	(4)
Cv	(US)	3.8	6.9	11.1	15.5	24.0	37.2	59.3	85.0	128
Cv	(UK)	3.2	5.7	9.2	12.9	20.0	31.0	49.4	70.8	107
Kvs	(DIN)	3.3	5.9	9.5	13.3	20.6	31.9	50.8	72.9	110

Acceptable Operating Range

Model	MC-COS-3	MC-COS-16
Primary Pressure Range	0.1 – 0.3 MPaG (15 – 45 psig)	0.2 – 1.6 MPaG (30 – 250 psig)
Secondary Pressure Adjustable Range (All conditions must be met)	0.01 – 0.05 MPaG (1.5 – 7 psig)	Within 10 – 84% of the primary pressure (Minimum adjustable pressure of 0.03 MPaG (5 psig)) Allowable pressure differential between 0.07 – 0.85 MPa (10 – 120 psi)
Maximum Operating Temperature	220 °C (428 °F)	
Minimum Adjustable Flow Rate	5% or greater of rated flow rate	5% or greater of rated flow rate NOTE: 10% or greater of rated flow rate for sizes 65 – 100 mm (2 1/2 – 4 in)

(1 MPa = 10.197 kg/cm²)

Correct Usage of the MC-COS Multi-control Valve



Install properly and **DO NOT** use this product outside the recommended operating pressure, temperature and other specification ranges. Improper use may result in such hazards as damage to the product or malfunctions which may lead to serious accidents. Local regulations may restrict the use of this product to below the conditions quoted.

1. The MC-COS should be operated only within its specifications.
2. Installing an ON/OFF Valve (Solenoid Valve or Motorized Valve)

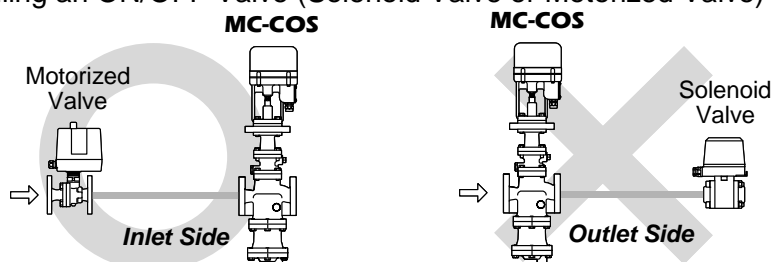

If an on-off valve, such as a motorized valve, is required to stop supply of steam to the steam-using equipment, install it at the inlet side of the MC-COS. If a solenoid valve is installed at the outlet of the MC-COS, its opening and closing will cause heavy chattering and may lead to damage of the piston and main valve. (When the on-off valve opens, the secondary pressure of the MC-COS changes from zero to the set pressure, passing through an area of the reducing ratio of less than 10:1, where adjustment is impossible, chattering occurs momentarily.)

To save energy, it is recommended to install the on-off valve as near to the boiler as possible.

NOTE: To prevent water hammer, it is recommended that a slow-acting motorized on-off valve be used. In particular, if a fast-acting on-off solenoid valve is used for frequent temperature control, the potential water hammer effect can damage the steam-using equipment and the MC-COS.

3. Installing a Control Valve

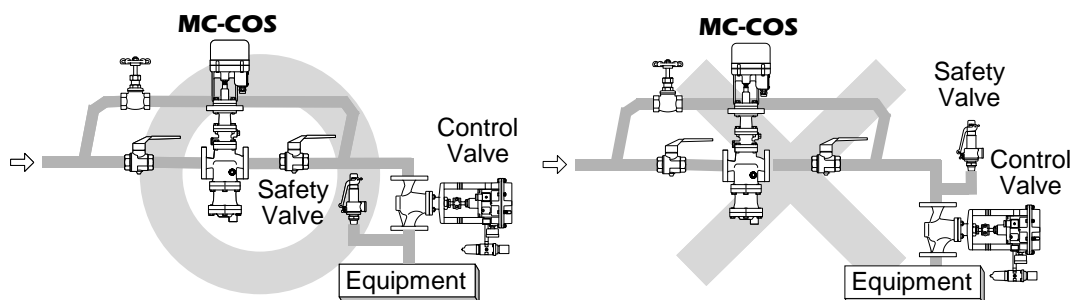

A control valve (i.e. for temperature control) installed between the MC-COS and the steam-using equipment (downstream of the MC-COS) may raise the pressure between the MC-COS and the control valve when the control valve is closed, depending on their spatial relationship. Therefore, the control valve should be installed close to the steam-using equipment. Also, a safety valve should be installed downstream of the control valve.

NOTE: When installing a safety valve to protect the steam-using equipment, be sure to install it on the steam-using equipment or directly before the inlet of the steam-using equipment. If the safety valve is installed between the MC-COS and a control valve, an eventual pressure rise could activate the safety valve.

4. Recommended Straight Pipe Runs

In order to ensure stable steam flow, the piping upstream and downstream of the MC-COS must be straight runs. If a MC-COS is installed either directly before or after an elbow or control valve, unevenness in steam flow may result in chattering and unstable pressure.

To ensure stable steam flow, it is recommended that the MC-COS be installed on straight runs of piping, as illustrated below.

1) Inlet (primary side) of the MC-COS

(d = pipe diameter)

Maintain a straight piping run of **10 d or more** when a manual valve, a strainer or an elbow, etc. is installed.

(Example: if nominal size is 25 mm (1 in), have 250 mm (10 in) or more)

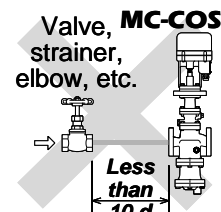
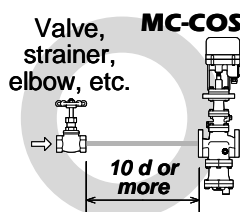

Maintain a straight piping run of **30 d or more** when an automatic valve (on-off valve) is installed.

(Example: if nominal size is 25 mm (1 in), have 750 mm (30 in) or more)

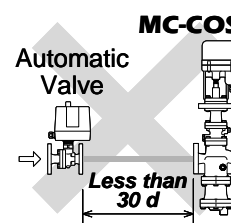
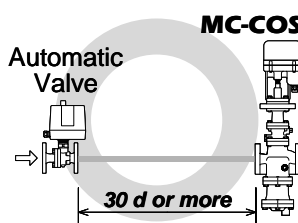

Maintain a straight piping run of **30 d or more** when another pressure reducing valve is installed. (Two-stage pressure reduction)

(Example: if nominal size is 25 mm (1 in), have 750 mm (30 in) or more)

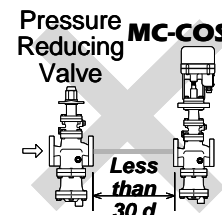
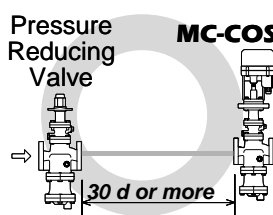

2) Outlet (secondary side) of the MC-COS

Maintain a straight piping run of **15 d or more** when a manual valve, a strainer or an elbow, etc. is installed.

(Example: if nominal size is 25 mm (1 in), have 375 mm (15 in) or more)

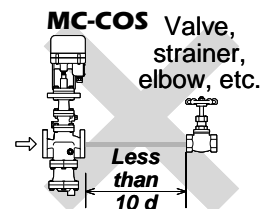
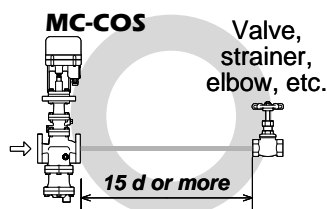

Maintain a straight piping run of **30 d or more** when a safety valve is installed.

(Example: if nominal size is 25 mm (1 in), have 750 mm (30 in) or more)

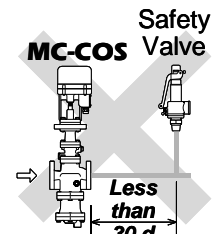
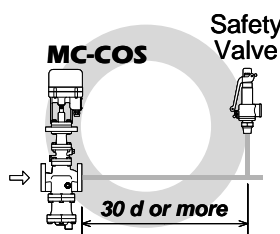

Maintain a straight piping run of **30 d or more** when a control valve or an automatic valve (on-off valve) is installed.

(Example: if nominal size is 25 mm (1 in), have 750 mm (30 in) or more)

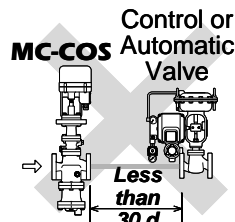
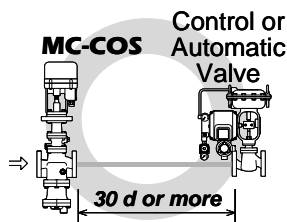

Configuration

15 – 50 mm (1/2 – 2 in)

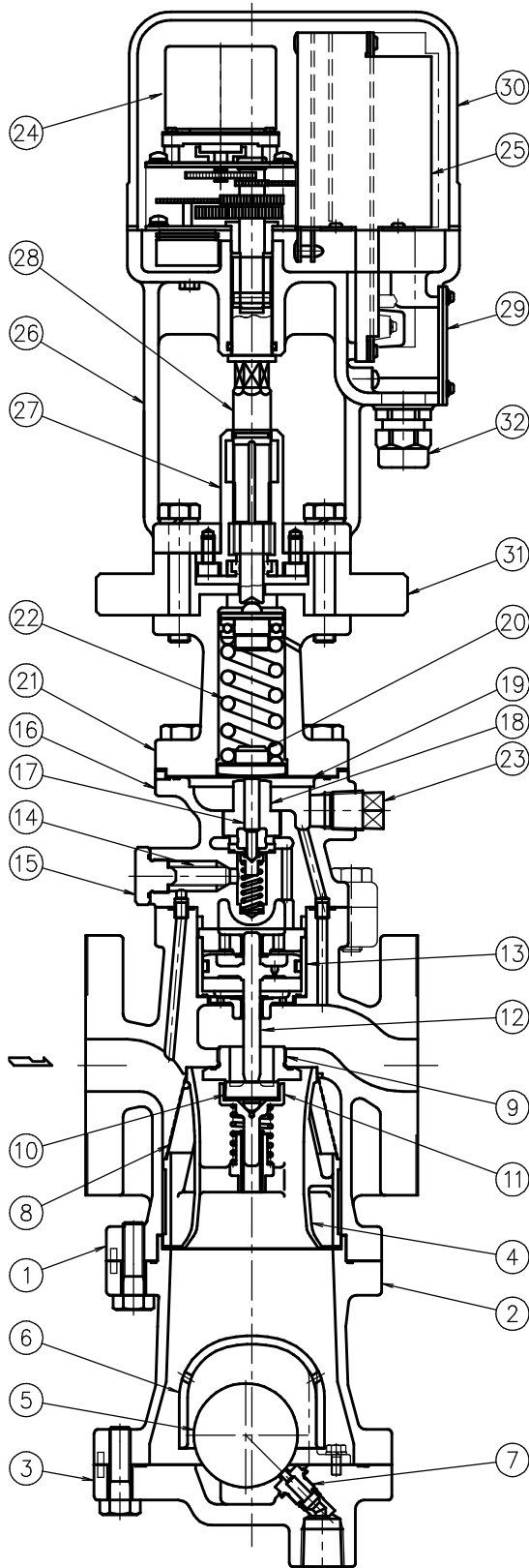

No.	Name
1	Main Body
2	Trap Body
3	Trap Cover
4	Separator
5	Float
6	Float Cover
7	Trap Valve Seat
8	Separator Screen
9	Main Valve Seat
10	Main Valve
11	Main Valve Holder
12	Piston
13	Cylinder
14	Pilot Screen
15	Pilot Screen Holder
16	Pilot Body
17	Pilot Valve Stem
18	Pilot Valve Seat
19	Diaphragm
20	Diaphragm Support
21	Spring Housing
22	Coil Spring
23	Plug – Sensing Line Port
24	Motor Unit
25	Drive Unit
26	Mounting Plate
27	Adjustment Screw Guide
28	Adjustment Screw
29	Terminal Block Cover
30	Motor Cover
31	Insulation Plate
32	Cable Lock

65 – 100 mm (2½ – 4 in)

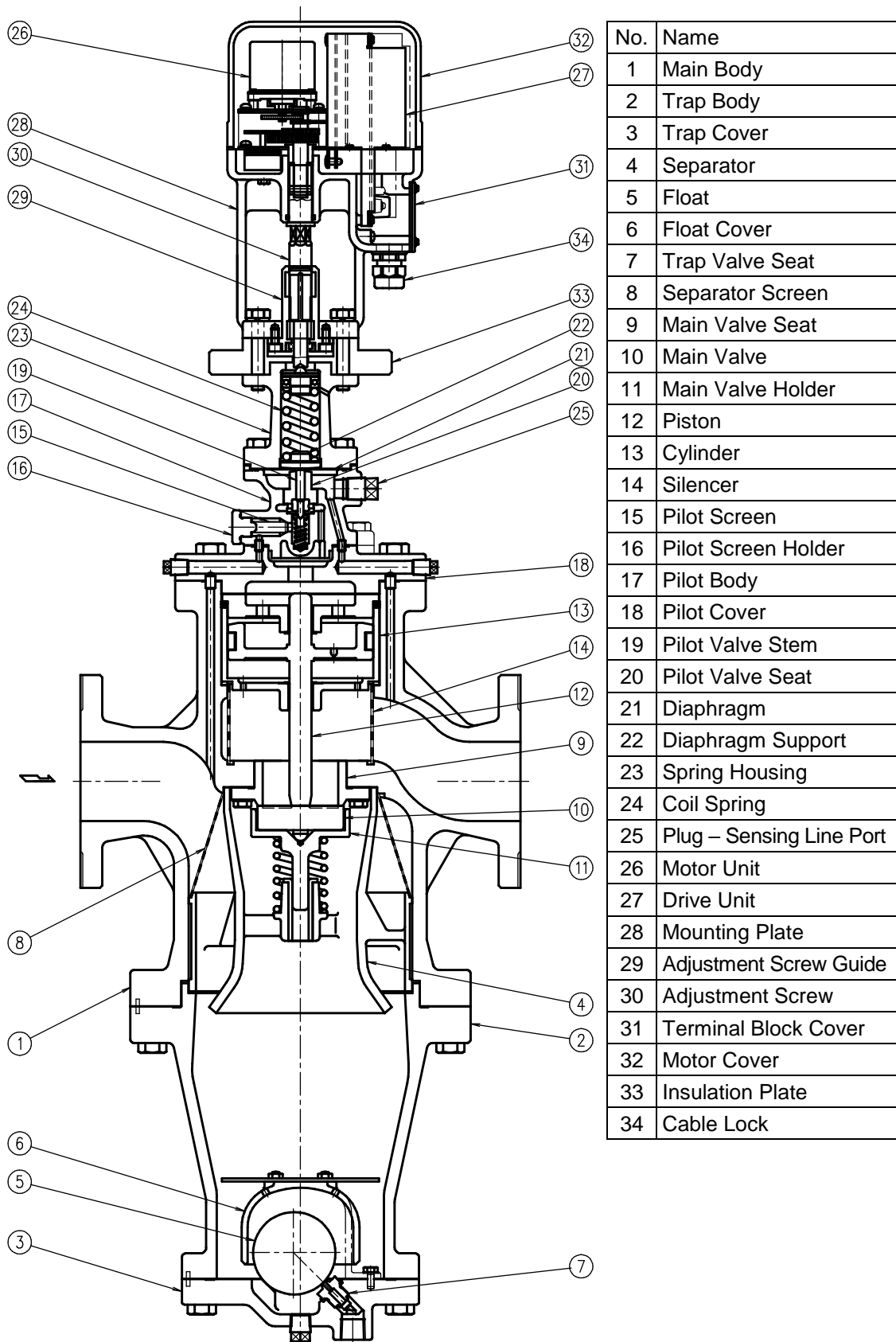

No.	Name
1	Main Body
2	Trap Body
3	Trap Cover
4	Separator
5	Float
6	Float Cover
7	Trap Valve Seat
8	Separator Screen
9	Main Valve Seat
10	Main Valve
11	Main Valve Holder
12	Piston
13	Cylinder
14	Silencer
15	Pilot Screen
16	Pilot Screen Holder
17	Pilot Body
18	Pilot Cover
19	Pilot Valve Stem
20	Pilot Valve Seat
21	Diaphragm
22	Diaphragm Support
23	Spring Housing
24	Coil Spring
25	Plug – Sensing Line Port
26	Motor Unit
27	Drive Unit
28	Mounting Plate
29	Adjustment Screw Guide
30	Adjustment Screw
31	Terminal Block Cover
32	Motor Cover
33	Insulation Plate
34	Cable Lock

Installation



Install properly and **DO NOT** use this product outside the recommended operating pressure, temperature and other specification ranges. Improper use may result in such hazards as damage to the product or malfunctions which may lead to serious accidents. Local regulations may restrict the use of this product to below the conditions quoted.



Use hoisting equipment for heavy objects (weighing approximately 20 kg (44 lb) or more). Failure to do so may result in back strain or other injury if the object should fall.



Take measures to prevent people from coming into direct contact with product outlets. Failure to do so may result in burns or other injury from the discharge of fluids.

Installation, inspection, maintenance, repairs, disassembly, adjustment and valve opening/closing should be carried out only by trained maintenance personnel.

Installation Environment

Avoid installation in the following types of environments:

- Locations with ambient temperatures above 50 °C (122 °F) or below 0 °C (32 °F)
- Locations with ambient humidity above 90% RH and below 10% RH
- Locations where corrosive gas is generated
- Locations with heavy vibration or shock
- Locations with high inductive interference or other factors that would have a harmful effect on electrical circuitry

1. Blowdown

Before installing the MC-COS, be sure to blow down all piping thoroughly. If this is not possible, perform a blowdown using the bypass valve. Blowdown is especially important for newly installed piping or after the system has been shut down for a long period of time.

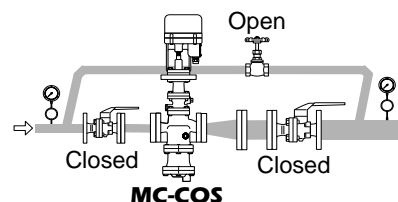

MC-COS
Blowdown with the Bypass Valve

2. Removing Seal and Cap

Before installation, be sure to remove all protective seals and caps covering the product inlet and outlets. (Found in 3 locations.)

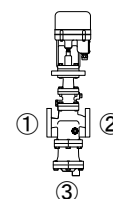

3. Installation Angle

Install the MC-COS vertically, so that the arrow mark on the body points horizontally in the direction of steam flow. Allowable inclination is 10 degrees in the fore-aft direction and 15 degrees side to side in the plane perpendicular to the steam flow line.

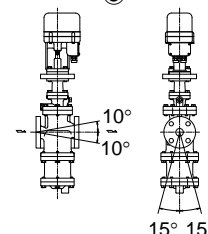

4. Spacer Installation

If spacing adjustment is necessary to accommodate installation, install a spacer on the outlet flange. The spacer should consist of a spacer, gaskets, bolts and nuts. Fit gaskets to both sides of the spacer between the MC-COS outlet and the pipe flange. Fasten with bolts and nuts.

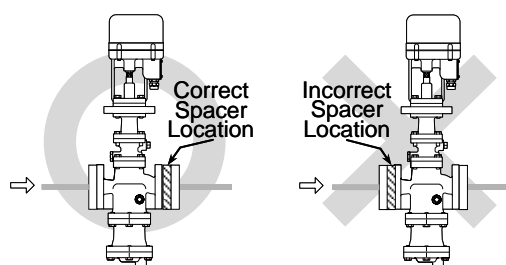

5. Piping Support

Install the MC-COS, paying attention to avoid excessive load, bending and vibration.

Support the inlet and outlet pipes securely.

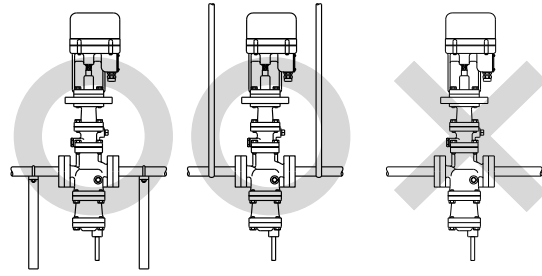

6. Maintenance Space

Leave sufficient space for maintenance, inspection and repair. (Unit: mm (in))

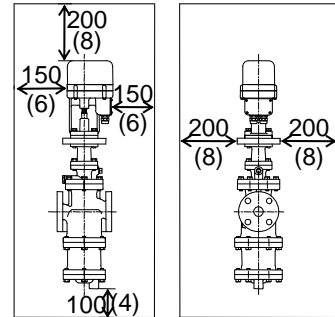

7. Trap Outlet Piping

For ease of maintenance, installation of a union connection is recommended for the trap outlet pipe. Connect the outlet pipe to a condensate return line, or extend it to a trench. In the case of the latter, make sure the end of the pipe is above the waterline. (Dirt and water may otherwise be sucked up by the vacuum formed during trap closure and system shutdown.)

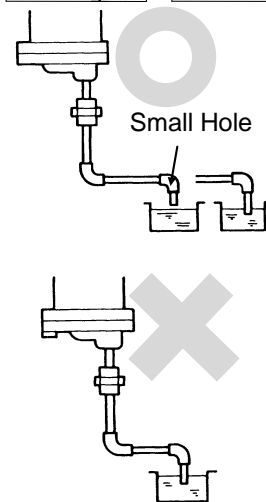

8. Pressure Sensor Installation (for pressure control)

The length of piping between the MC-COS and pressure sensor should be no more than 5 m (17 ft). If the piping distance is too great, pressure loss and delay of pressure change along this distance will increase, resulting in steam flowrate fluctuations. Steam fluctuations at the pressure sensor may impair the stability of the pressure control. Ensure a straight piping run of at least 15 d upstream and 5 d downstream from the pressure sensor.

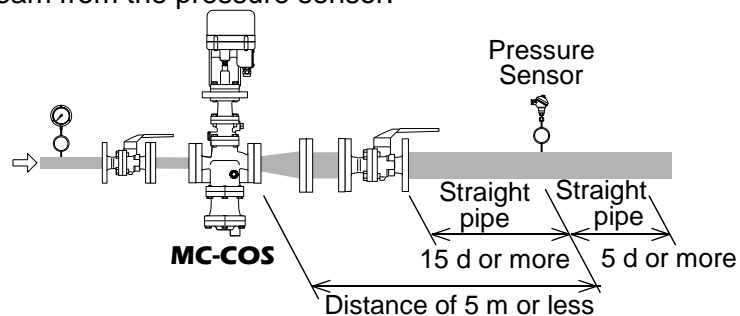

9. Blowdown Valve (requires optional plug)

In an environment of heavy dirt or scale, or when the steam-using equipment is used only periodically, such as for room heating equipment, be sure to use a blowdown valve.

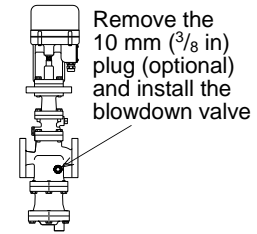

1. Remove the plug from the (pressureless) main body.
2. Install the blowdown valve.
3. Open the blowdown valve (while MC-COS is pressurized) and blow any residual dirt and scale off the separator screen.
4. Periodically activate the blowdown valve to keep the system free of dirt and scale.

10. Piping Size/Diffuser

If the secondary steam flow velocity is expected to be more than 30 m/s (100 ft/s), install a diffuser in order to keep the flow velocity below 30 m/s (100 ft/s).

If the distance between the MC-COS and the steam-using equipment is great, a possible drop in pressure should be taken into consideration when selecting the piping size. (d = pipe diameter)

In addition, when installing the strainer, the strainer screen should be either at the 3 o'clock or 9 o'clock position to prevent condensate accumulation.

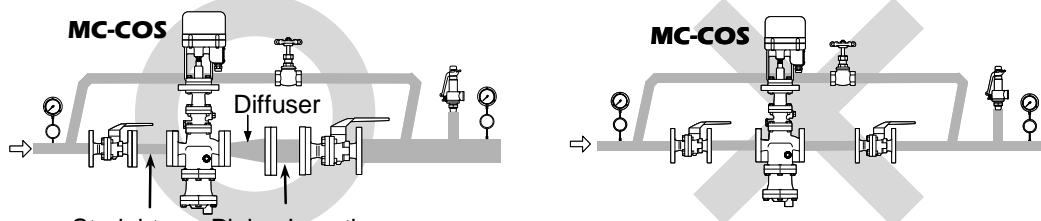

Straight-run Piping Lengths:
Upstream = 10 d or more / Downstream = 15 d or more

11. Two-stage Pressure Reduction

Install a pressure reducing valve at the inlet side of MC-COS whenever the pressure cannot be reduced to the desired level with a single MC-COS due to operating range limitations, such as when the reduction ratio is greater than 10:1.

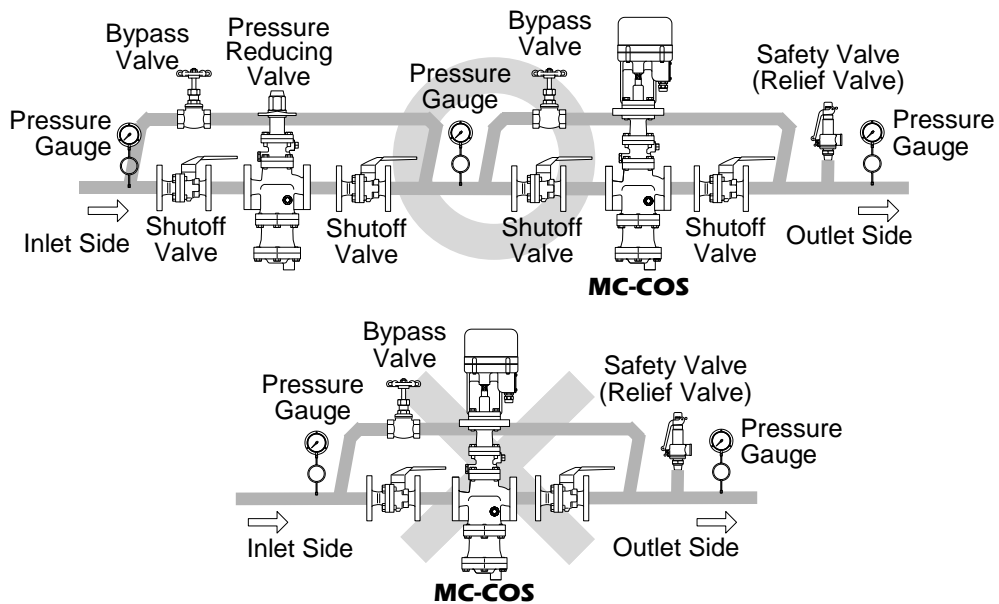

12. Accessories

Always install a shut-off valve, pressure gauge and bypass lines at both inlet and outlet. Ball valves, which will not retain condensate, are recommended for inlet and outlet shut-off valves. The bypass pipe should be at least $\frac{1}{2}$ of the size of the inlet (primary side) pipe. If installing a strainer before the MC-COS, horizontal installation with the basket in the same horizontal plane to the piping is recommended in order to prevent condensate pooling.

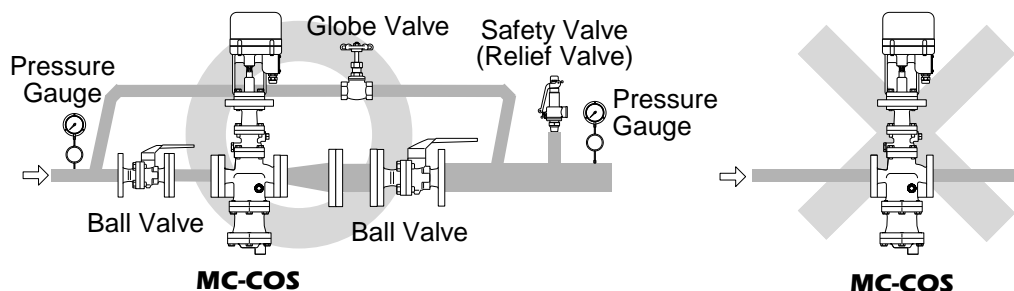

13. External secondary pressure-sensing line (when required)

North American Models are factory prepared for external sensing.

An external sensing line **MUST** be installed.

DO NOT SUPPLY STEAM until all piping and a 10 mm ($\frac{3}{8}$ in) secondary pressure sensing line with a slightly falling pitch have been properly installed. Install a shutoff valve in the pressure sensing line for maintenance purposes.



Keep the shutoff valve open at all times during operation. If the shutoff valve is closed, MC-COS will fully open and **PRIMARY PRESSURE WILL BE SUPPLIED TO THE EQUIPMENT** (see "Piping Example" on next page).

Non-North American Models:

Factory-standard MC-COS employs an internal secondary pressure-sensing channel built into the body, saving the need to install an external pressure-sensing line to detect the secondary pressure.

Installation of an external secondary pressure-sensing line involves closing the internal pressure-sensing channel and installing a line from the sensing line port to the point where pressure should be controlled. This can increase stability of pressure control where steam loss in secondary piping and flowrate fluctuation is high. In addition, the rated flowrate will be greater than an internal pressure-sensing channel under the operational pressure reduction ratio of 2:1 or more.

Installation procedure

- 1) Loosen and remove the bolts that attach the pilot body to the main body (15 – 50 mm ($\frac{1}{2}$ – 2 in)) or the pilot cover (65 – 100 mm ($2\frac{1}{2}$ – 4 in)) and remove the pilot body.
- 2) Install the blind pin (optional) by first removing the connecting tube from the main body or pilot cover and then substituting the blind pin.
- 3) Re-install the pilot body and fasten the bolts evenly to the proper torque.
- 4) Remove the plug Rc(PT) $\frac{3}{8}$ or NPT $\frac{3}{8}$ and connect the secondary pressure sensing line.
- 5) Install the secondary pressure sensing line with a slightly falling pitch. The end of the secondary pressure sensing line should be connected to the place on the main piping where the pressure is to be sensed (see the piping example on next page). A shut-off valve and union should be installed in the secondary pressure sensing line.

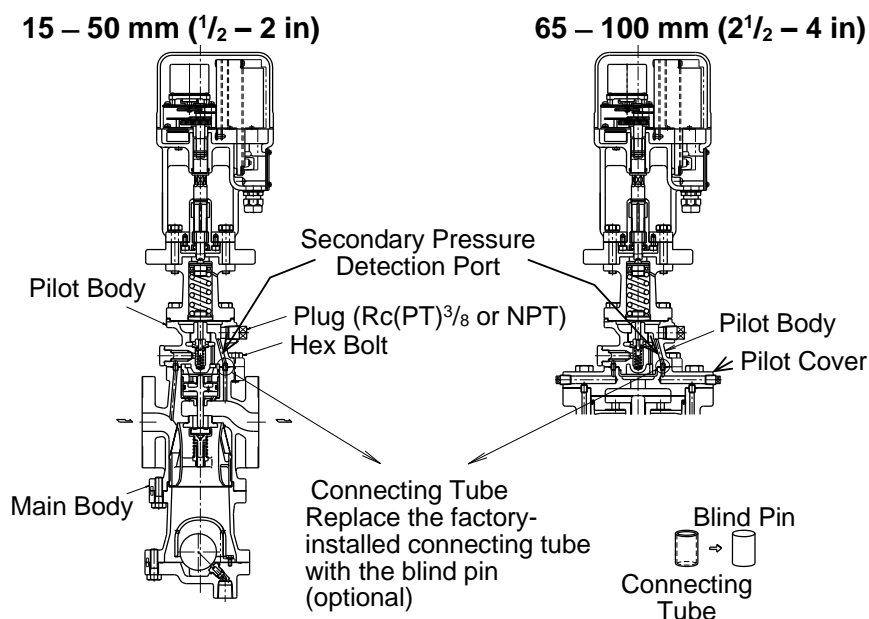

Piping Example:

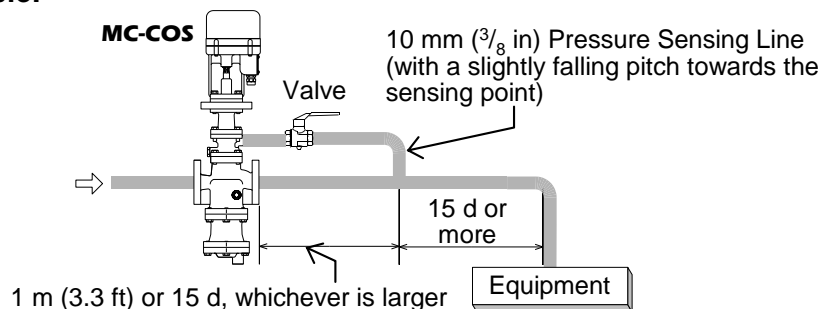

14. Internal sensing for North American models

All models except North American models are factory prepared for internal sensing. When internal pressure sensing is required for North American models, please contact the nearest TLV representative to request both a connecting tube, which must be installed in place of the blind pin, and a threaded secondary pressure sensing plug.* Follow the connecting tube installation procedure shown below:

- 1) Loosen and remove the four (4) bolts that attach the pilot body to the main body (15 – 50 mm, $1/2$ – 2 in) or the pilot cover (65 – 100 mm, $2\frac{1}{2}$ – 4 in), and remove the pilot body.
- 2) Install the connecting tube by first removing the blind pin from the secondary side of the main body or pilot cover and then substituting the connecting tube.
- 3) Re-install the pilot body and fasten the four (4) bolts evenly.
Consult page 26 in this manual for torque requirements of these bolts.
- 4) If a secondary pressure sensing pipe has previously been installed, remove it and be certain to install the threaded secondary pressure sensing line plug in its place.

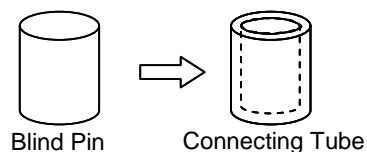

*Internal sensing should not be used when 15 mm ($1/2$ in) and 20 mm ($3/4$ in) MC-COS-16 will be used below 0.3 MPaG (45 psig) and 0.1 MPaG (15 psig) respectively, and below 50% of primary pressure.

Wiring

Wiring Notes

Background electromagnetic noise that has no effect on analog equipment may cause digital equipment to malfunction or fail. To prevent adverse effects from electromagnetic (EM) interference, carefully follow the wiring instructions below:

1. Power Source

- 1) If there is EM noise from the power source, a filter should be used. To prevent interference, do not bundle the EM filter's power source input and output lines together.
- 2) Although there is a built-in fuse in the controller, there is no power switch. It is required that a power switch be installed on an external circuit near the main unit. Do not install a power switch between the EM filter and the valve, as this will reduce the effectiveness of the filter.

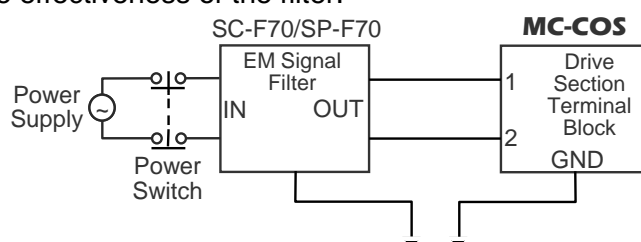

- 3) A power cable is not included with the unit. See "Wiring Instructions".
- 4) Install an overcurrent protection device on the power supply lines (both poles) to prevent overcurrent.
Recommended rating of the device: 250V/2A, delay type

2. Input/Output Signal Lines for Valve Operation

- 1) Use shielded cables for the I/O signal lines.
Connect the shielded cables to the receiver's shield terminal.
- 2) Separate the I/O signal cables from power cables, drive cables, and EM noise-generating equipment. Do not insert I/O signal cables in common piping or ducts with aforementioned cables.

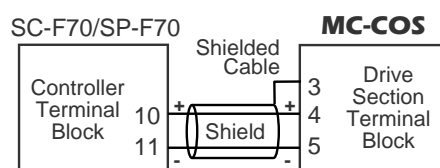

3. Ground

- 1) Be sure to ground the MC-COS and the controller.
- 2) Use a one-point ground at the same point as the ground for the controller to be used with the valve. Do not use extension wiring. Failure to ground the valve as specified may cause it to malfunction.
- 3) For the ground terminal, use a flexible copper wire, at least 2 mm² (0.003 in²).
Ground with a ground resistance of 100 Ω or less (Class 3 ground).

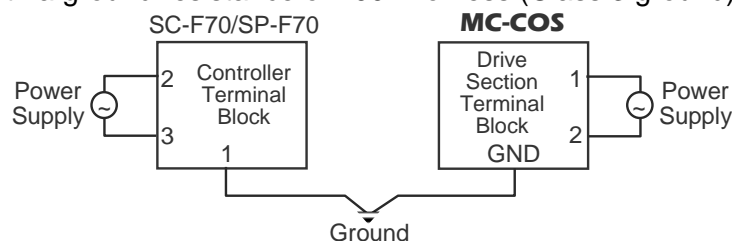

Wiring Instructions



CAUTION Make sure the power supply is OFF before carrying out work on the wiring or inspections involving disassembly. If such work is carried out with the power on, there is a danger that equipment may malfunction or electric shock may occur, leading to injury or other accidents.



CAUTION Make sure that wiring work requiring a special license is carried out by qualified personnel. If carried out by unqualified personnel, overheating or short circuits leading to injury, fires, damage or other accidents may occur.

Drive Section Terminal Box

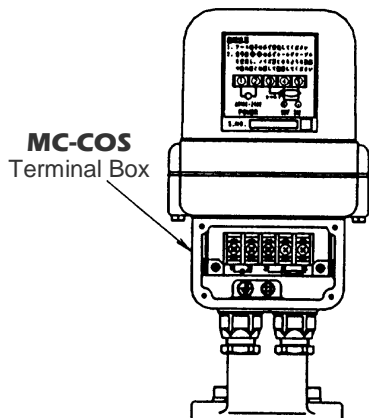

Drive Section Terminal Block

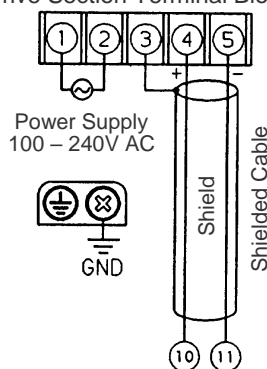

SC-F70/SP-F70 Controller Terminal Block

When making a connection to the terminal block, use crimp-style jacks (for M4) with insulation sleeves.

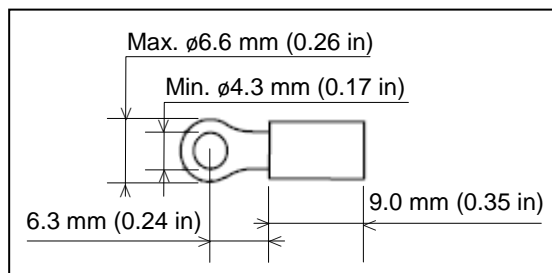

Recommended Cable Specifications

	Actuator Terminal No.	Cable Specifications		
		Minimum Cross Section mm ² (in ²)	Maximum Wire Gauge No. (AWG)*	Cable Type
Power Source	1, 2	1.25 (0.002 in ²)	16	Cabtyre Cable
GND	\oplus	2.00 (0.003 in ²)	14	
Valve Operation Signals	3 (shield), 4 (+), 5 (-)	0.75 (0.001 in ²)	18	2 conductor shielded cable

* (American Wire Gauge)

Setting the Valve Coefficient

About the Valve Coefficient

1. Features of the MC-COS

The MC-COS valve has a pressure self-adjustment function with the following features:

- 1) Maintains the secondary steam pressure at a stable level even when the primary steam pressure and secondary steam flow fluctuate.
- 2) Maintains the interrelationship between the secondary steam pressure and the stroke position of the pressure adjustment screw determined by the drive section.

2. What is the valve coefficient?

The valve coefficient expresses the relationship between the secondary steam pressure and the stroke position of the pressure adjustment screw on the MC-COS. There are five different valve coefficients; labeled A through E. Valve coefficients are derived by TLV for each valve through tests before shipment from the factory. They are stamped on the valve coefficient nameplate label attached to the valve and a removable label to be utilized for putting the valve coefficients into the controller.

Combining the MC-COS and the TLV SC-F70 or SP-F70 Controller

The SC-F70 digital indicator controller and SP-F70 programmable indicator controller made by TLV use proprietary control algorithms designed to take full advantage of MC-COS's potential. Examples include MC-COS's high stability, resistance to external disturbances and its precise response to setting changes. Combining the MC-COS with these controllers provides a level of control not possible with other conventional control valves and PID controllers.

Setting the Valve Coefficient

In order to fully utilize the MC-COS, be sure to provide the SC-F70 or SP-F70 controller with the MC-COS valve coefficient.

Failure to do so will make AUTO mode operation impossible and an error message will be displayed on the controller.

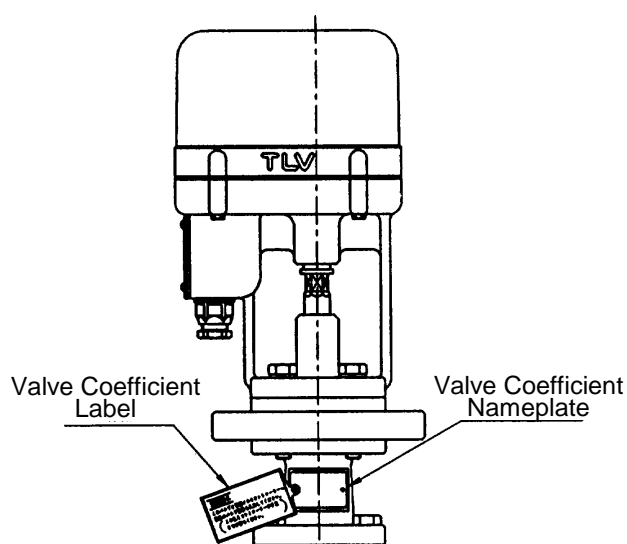

Operation



When using this product, NEVER stand close to, or leave tools anywhere near moving parts, such as the adjustment screw. Contact with moving parts or objects becoming caught in moving parts could lead to injury or damage or other accidents.

Procedure

1. Operational check

- 1) Before turning ON the power, check to make sure all cable connections are correct.
- 2) To close the valve, send an operation signal value of 0% (4 mA) or less from the controller to MC-COS and maintain that value.

- 3) Turn ON the power to the actuator.

- 4) The MC-COS valve should be closed.

- Check to make sure no steam is flowing to the secondary side.
- Check to see whether there is a slight back and forth motion of the pressure adjustment screw. If there is, this may be due to EM interference.

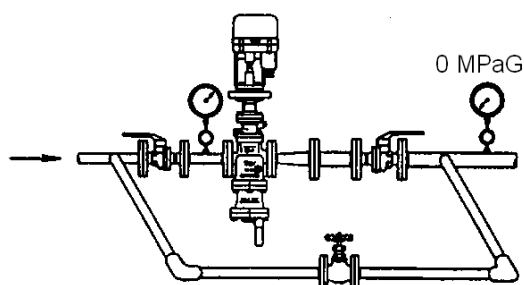

- 5) On the controller, increase the value of the operation signal to the MC-COS.

- Check to make sure that, when viewed from above, the adjustment screw in the drive section is rotating clockwise while moving downward.
- Check to make sure that steam begins to flow to the secondary side of the MC-COS and the secondary steam pressure rises.

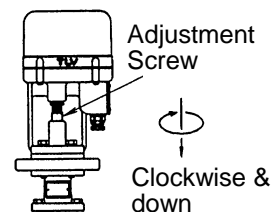

- 6) At the same time, begin reducing the value of the operation signal to the MC-COS on the controller.

- Check to make sure that, when viewed from above, the adjustment screw in the drive section is rotating counter-clockwise while moving upward.
- Check to make sure that the steam pressure on the MC-COS secondary side decreases.

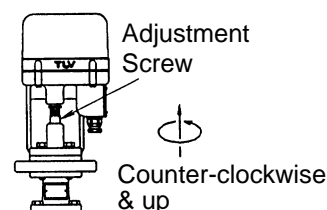

- 7) In the event that an abnormality is detected in operation when checking with the above procedure, consult the Troubleshooting chapter in this manual and take the appropriate remedial steps.

2. AUTO operation

Enter target settings and other necessary parameters into the controller and start AUTO operation. The drive section of the MC-COS will begin operating automatically in response to the operation signals from the controller.

In the Event of a Power Outage/Restoration



CAUTION Make sure the power supply switch is OFF before carrying out work on the wiring or inspections involving disassembly.

If such work is carried out with the power on, there is a danger that equipment may malfunction or electric shock may occur, leading to injury or other accidents.

1. When the power to the drive section has been cut off:

The drive section will stop at the position it was at just before the power was cut off. As a result, the pressure of the steam supplied to the equipment will be maintained at the pressure just before the power went off.

If the supply of steam needs to be stopped while the power is cut off, install an additional ON-OFF valve, which closes when the power is cut off, on the primary side of the MC-COS.

2. When only the operation signal to the actuator has been cut off:

The actuator will rotate counter-clockwise to raise the adjustment screw to the 0% or lower position. As a result, the MC-COS will close, cutting off the supply of steam to the secondary side.

3. When power is restored:

If the power comes back on after 5 or more seconds have passed, the adjustment screw (actuator) will return to the position specified by the operation signals from the controller.

For circuit safety, if power has been recovered in less than 5 seconds after it was cut off, the adjustment screw (actuator) will not return to the position specified by the operation signals from the controller.

To restore normal operation, the power should be turned ON after 5 or more seconds have passed from when it was cut off. If normal operation cannot be confirmed, turn the power OFF, and then back ON after 5 or more seconds have passed.

Manual Operation

1. Before beginning manual operation, turn OFF the power to the drive section.

2. Using a wrench as shown in the figure below, slowly turn the adjustment screw. Be careful not to apply too much force. (A torque of about 7 N·m (5 lbf·ft) will be required to turn the adjustment screw with the wrench.)

3. Turning the adjustment screw clockwise when viewed from above will INCREASE the secondary steam pressure.

4. Turning the pressure adjustment screw counter-clockwise when viewed from above will DECREASE the secondary steam pressure.

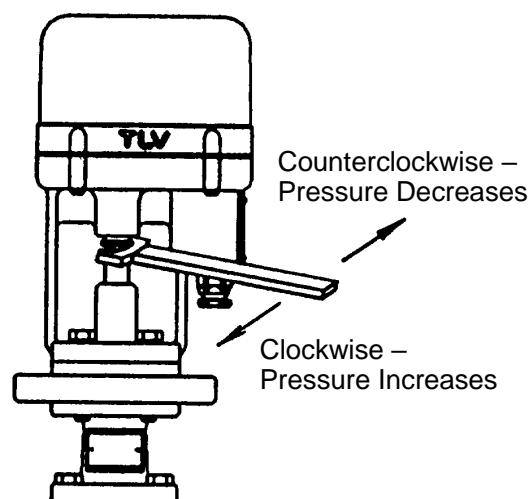

Inspection and Maintenance



Take measures to prevent people from coming into direct contact with product outlets. Failure to do so may result in burns or other injury from the discharge of fluids.



Be sure to use only the recommended components when repairing the product, and NEVER attempt to modify the product in any way. Failure to observe these precautions may result in damage to the product or burns or other injury due to malfunction or the discharge of fluids.

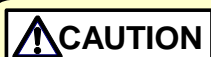

Make sure the external power supply switch is OFF before carrying out work on the wiring or inspections involving disassembly. If such work is carried out with the power on, there is a danger that equipment may malfunction or electric shock may occur, leading to injury or other accidents.

Operational Check

To ensure long service life of the MC-COS, the following inspection and maintenance should be performed regularly.

Part	Inspection and Maintenance Frequency
Screens (Separator and Pilot)	Disassemble and clean annually. If there is substantial blockage, install a strainer (approximately 60 mesh) ahead of the MC-COS.
Main Valve, Main Valve Seat, Pilot Valve and Pilot Valve Seat	Replace after approximately 15,000 hours. If there is chattering or dirt, premature wear may result.
Piston Ring	Replace after approximately 8,000 hours. If there is chattering or if scale build-up is severe, premature wear may result.
Piston	Replace after approximately 30,000 hours. If hunting or chattering takes place, premature wear may result.
Trap Valve Seat	Replace after approximately 40,000 hours. If scale build-up is severe, blockage may occur in a short period of time.
Diaphragm	Replace after approximately 30,000 hours. If hunting or chattering takes place, cracks or fatigue may develop in a short period of time.
Bearing (in spring housing)	Replace after approximately 8,000 hours. If the ambient temperature is high, premature wear may result.

Disassembly



WARNING

NEVER apply direct heat to the float. The float may explode due to increased internal pressure, causing accidents leading to serious injury or damage to property and equipment.



CAUTION

Use hoisting equipment for heavy objects (weighing approximately 20 kg (44 lb) or more). Failure to do so may result in back strain or other injury if the object should fall.



CAUTION

When disassembling or removing the product, wait until the internal pressure equals atmospheric pressure and the surface of the product has cooled to room temperature. Disassembling or removing the product when it is hot or under pressure may lead to discharge of fluids, causing burns, other injuries or damage.

It is a recommended practice to dismantle and inspect the MC-COS once a year for preventive maintenance purposes. It is especially important to do so immediately after the initial run of a new line or before or after equipment such as a heater is out of service for a long period of time.

(Installation, inspection, maintenance, repairs, dismantling, adjustment and valve opening/closing should be carried out only by trained maintenance personnel.)

Before Disassembly

Remove all steam from the piping (both upstream and downstream). Set the value of the valve operation signal from the controller to the MC-COS to 0% (4 mA) or less. The drive section will operate in response to the valve operation signal, with the adjustment screw moving counterclockwise and up to close the valve. Wait for the body to cool before attempting to remove the MC-COS from the line. Turn OFF the power to both the drive section and the valve operation signal (controller) and disconnect the cables. Then remove inlet and outlet flange retaining bolts and nuts to permit removal of the MC-COS. Secure the MC-COS in a vise to perform the inspection.

Disassembling the Adjustment Section

Loosen the adjustment screw completely and remove the bolts from the spring housing. Grasp the mounting plate and lift the spring housing straight up and off. Having removed the spring housing, you will see the diaphragm support, coil spring, bearing and spring retainer.

⇒ Check to make sure there is no dirt, etc. inside the spring housing, and check for seizure or any damaged screw threads. Then, using a wrench, turn the adjustment screw back and forth. Check to make sure that it turns smoothly. A slight torque is necessary since the motor has a rotational load.

If the adjustment screw does not rotate smoothly, contact TLV immediately.

NOTE: Do not remove the drive section cover. The drive section, which contains precision electronic components, is maintenance-free.

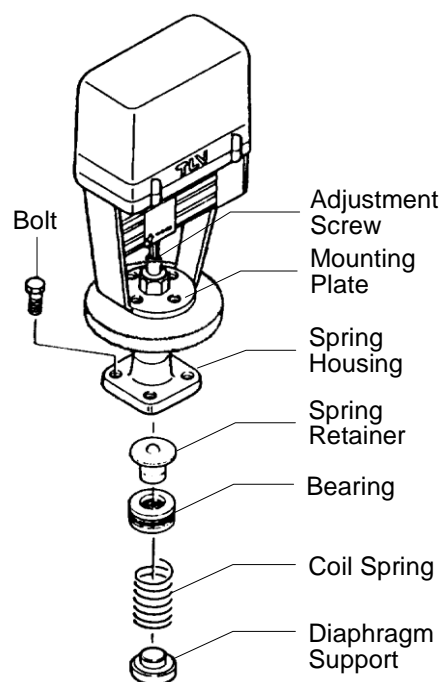

Disassembling the Pilot Section

The diaphragm is removed by utilizing the notch in the pilot body. Loosen and remove the pilot valve seat with a box wrench. Pick up the pilot valve and the pilot spring with a pair of tweezers. Loosen and remove the pilot screen holder to remove the pilot screen.

⇒ Check for any fault on the seat of the pilot valve and the pilot valve seat, flaws on the gaskets, and clogging of the pilot screen. Check for deformation, corrosion or faults on the diaphragm. The diaphragm should be convex (open downward), with the printed UP mark on the top.

15 – 50 mm (1/2 – 2 in)

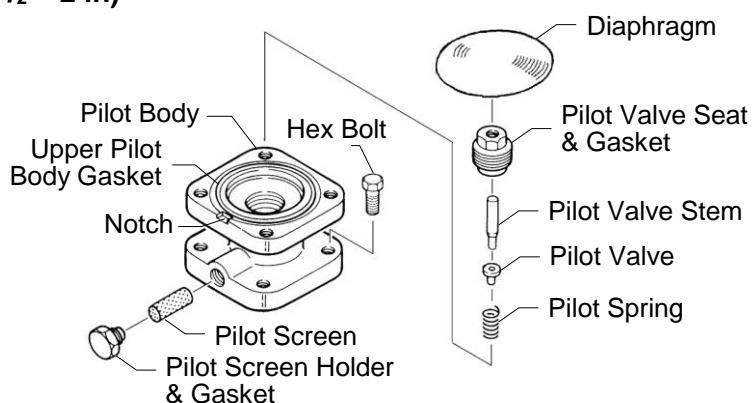

65 – 100 mm (2 1/2 – 4 in)

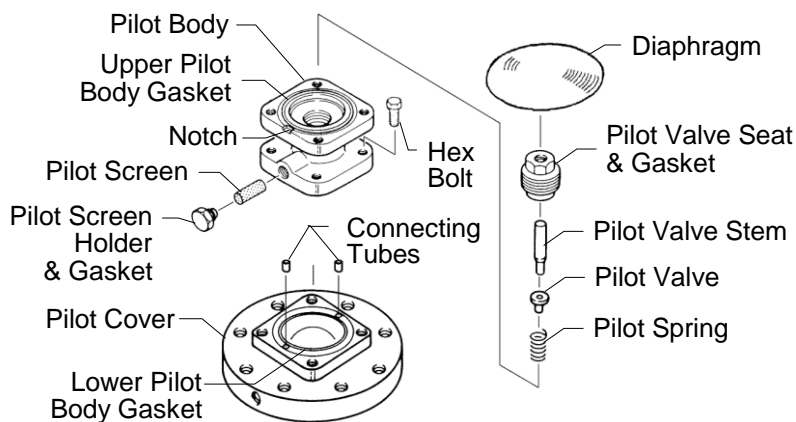

Disassembling the Piston Section

Remove the pilot body after loosening and removing the bolts. During this process, pay attention not to lose the two connecting tubes. Remove the piston, cylinder, and the silencer (for 65 – 100 mm (2½ – 4 in) only) from the main body. Then remove the piston ring and the tension ring from the piston.

NOTE: Do not apply too much force when removing the piston ring and tension ring.

⇒ Check for the interior of the cylinder, the exterior of the piston rings, the small hole on the piston and the cylinder gaskets for any fault or abnormality.

15 – 50 mm (½ – 2 in)

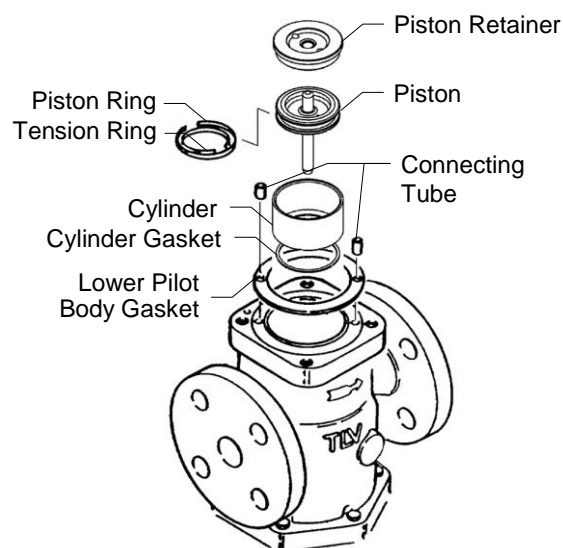

65 – 100 mm (2½ – 4 in)

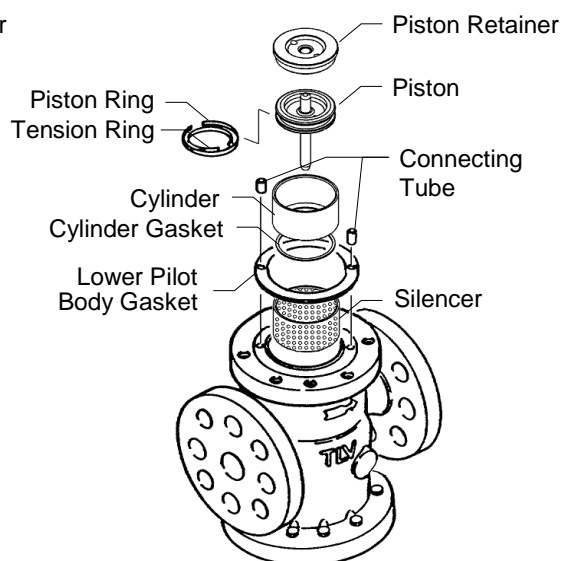

Disassembling the Separator and Main Valve Sections

Turn the MC-COS upside down for easy dismantling of the separator and main valve. Loosen the bolts and remove the trap body. Be careful, as the separator may drop off when the MC-COS is returned to the normal attitude.

Removal of the separator and pressed-in sleeve permits removal of the main valve spring, the main valve, the main valve holder and the separator screen. Remove the main valve seat from the main body with a box wrench.

⇒ Check for damage on the seating and sliding surfaces of the main valve and main valve holder, the seating surface of the main valve seat and the gaskets, and for clogging of the separator screen.

[At startup following shutdown for a long period, always blow down the piston section of the main body through the plug (if optional plug is supplied).]

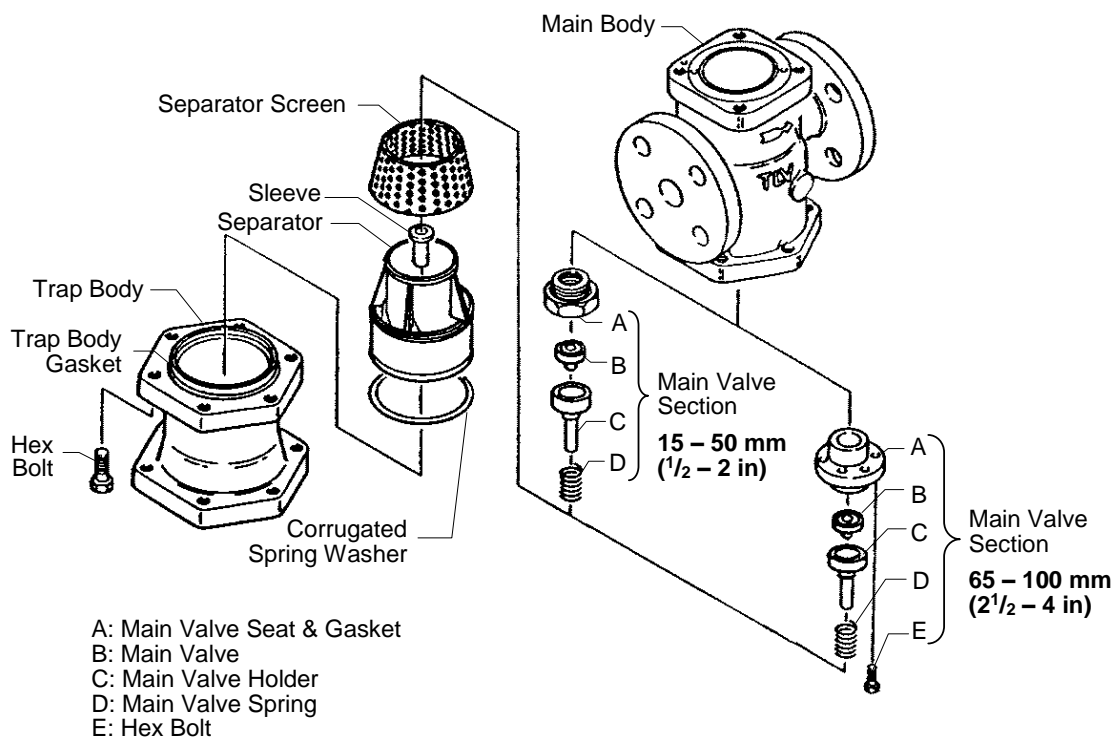

Disassembling the Steam Trap Section

Loosen the bolts and remove the trap cover. Be careful, as hot condensate may splash out.

Remove the bolts from the trap cover and the float cover to reveal the float. Remove the float, then loosen the trap valve seat with a box wrench and remove it.

⇒ Check to verify that there is no deformation of the float, abnormality in the trap valve seat or dirt accumulation in the trap cover.

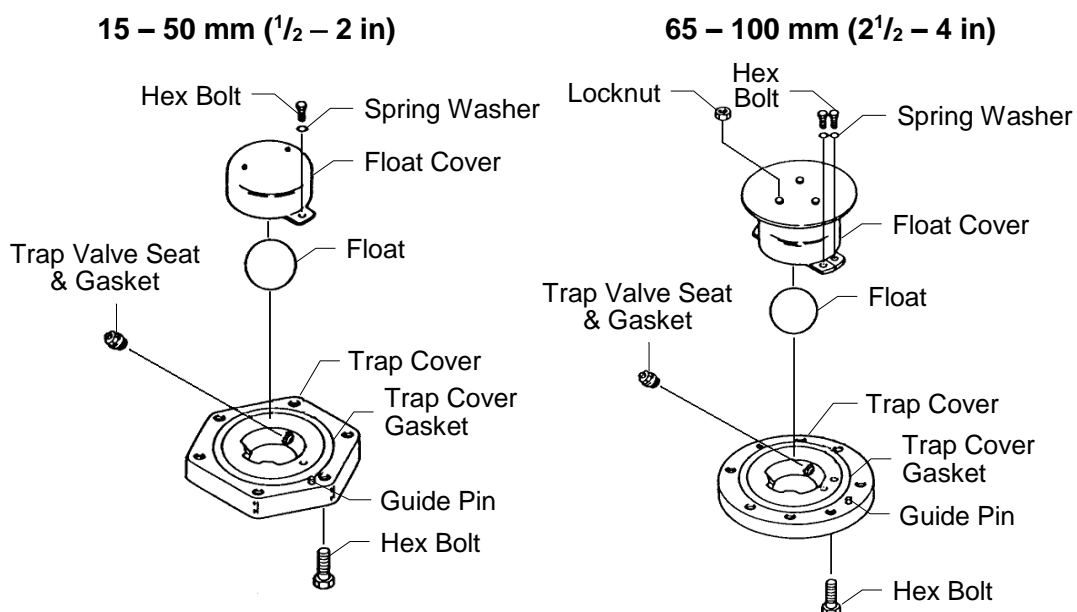

Cleaning

After inspection and removal of any abnormality, clean and reassemble the parts. The following parts will require cleaning before reassembly:

Trap Cover	Main Valve	Pilot Screen
Float	Main Valve Holder	Pilot Valve
Trap Valve Seat	Piston	Pilot Valve Seat
Separator Screen	Piston Ring	
Main Valve Seat	Cylinder	

It is permissible to clean using water, however cleaning with a mild detergent is recommended for more effective cleaning.

Exploded View

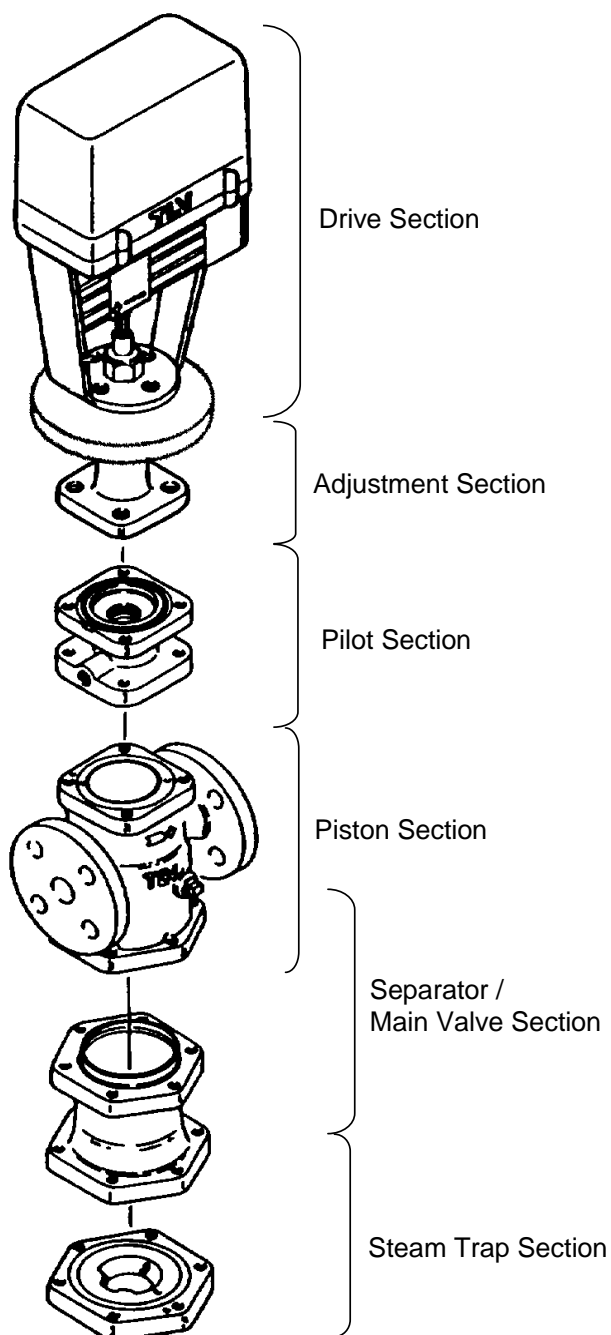

NOTE: The shape of individual parts may vary depending on the model size.

Reassembly

Assemble the unit using the same procedure as used for disassembling it; but in reverse order. Observe the following precautions:

1. The PTFE gaskets may be re-used if free from fault, crushing or deformation.
2. Apply anti-seize to the threaded portion of screws and bolts and adjustment screw. Apply a small amount of anti-seize to the threads of the main valve seat, pilot valve seat and pilot screen holder. Apply anti-seize carefully to ensure it does not come into contact with other parts.
3. Fasten the bolts one at a time in an alternating diagonal pattern to provide uniform seating.
4. After assembly, make sure that the piston and the pilot valve operate smoothly without binding.
 - 1) Fit the piston ring to the outside of the tension ring
 - 2) The ring gaps should be opposite each other.
5. Standard fastening torque and the distance across flats to be used are as follows:

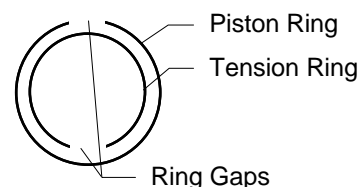

Assembling the Piston Ring

Part	Size		Distance Across Flats		Tightening Torque	
	mm	(in)	mm	(in)	N·m	(lbf·ft)
Bolt for Mounting Plate/Spring Housing	All		17	(²¹ / ₃₂)	30	(22)
Bolt for Spring Housing/Pilot Body	All		17	(²¹ / ₃₂)	40	(29)
Pilot Valve Seat	All		19	(³ / ₄)	70	(51)
Pilot Screen Holder	All		24	(¹⁵ / ₁₆)	40	(29)
Bolt for Pilot Body/Main Body	15 – 40	(¹ / ₂ – 1 ¹ / ₂)	17	(²¹ / ₃₂)	60	(44)
	50	(2)	19	(³ / ₄)	70	(51)
Bolt for Pilot Body/Pilot Cover	65 – 100	(2 ¹ / ₂ – 4)	17	(²¹ / ₃₂)	60	(44)
Bolt for Pilot Cover/Main Body	65, 80	(2 ¹ / ₂ , 3)	19	(³ / ₄)	70	(51)
	100	(4)	24	(¹⁵ / ₁₆)	150	(110)
Bolt for Main Body/Trap Body, Trap Body/Trap Cover	15 – 40	(¹ / ₂ – 1 ¹ / ₂)	17	(²¹ / ₃₂)	60	(44)
	50 – 80	(2 - 3)	19	(³ / ₄)	70	(51)
	100	(4)	24	(¹⁵ / ₁₆)	150	(110)
Main Valve Seat	15, 20	(¹ / ₂ , ³ / ₄)	36	(¹⁷ / ₁₆)	100	(73)
	25	(1)	41	(¹⁵ / ₈)	125	(92)
	32, 40	(¹ / ₄ , 1 ¹ / ₂)	60	(2 ³ / ₈)	250	(185)
	50	(2)	70	(2 ³ / ₄)	300	(220)
Bolt for Main Valve Seat	65, 80	(2 ¹ / ₂ , 3)	13	(¹ / ₂)	30	(22)
	100	(4)	17	(²¹ / ₃₂)	40	(29)
Bolt for Float Cover	15, 20	(¹ / ₂ , ³ / ₄)	8	(⁵ / ₁₆)	7	(5)
	25 – 40	(1 – 1 ¹ / ₂)	10	(³ / ₈)	10	(7)
	50 – 100	(2 – 4)	13	(¹ / ₂)	20	(15)
Trap Valve Seat	15, 20	(¹ / ₂ , ³ / ₄)	11	(⁷ / ₁₆)	10	(7)
	25 – 40	(1 – 1 ¹ / ₂)	13	(¹ / ₂)	15	(11)
	50 – 80	(2 - 3)	17	(²¹ / ₃₂)	40	(29)
	100	(4)	19	(³ / ₄)	55	(40)

(1 N·m ≈ 10 kg·cm)

- NOTE: - If a torque greater than that recommended is applied, the body or components may be damaged.
- Coat all threaded portions with anti-seize.
 - If drawings or other special documentation were supplied for the product, any torque given there takes precedence over values shown here.

Troubleshooting



WARNING NEVER apply direct heat to the float. The float may explode due to increased internal pressure, causing accidents leading to serious injury or damage to property and equipment.



CAUTION When disassembling or removing the product, wait until the internal pressure equals atmospheric pressure and the surface of the product has cooled to room temperature. Disassembling or removing the product when it is hot or under pressure may lead to discharge of fluids, causing burns, other injuries or damage.



CAUTION When using this product, NEVER stand close to, or leave tools anywhere near moving parts, such as the adjustment screw. Contact with moving parts or objects becoming caught in moving parts could lead to injury or damage or other accidents.

This product is shipped after stringent checks and inspection and should perform its intended function for a long period of time without failure. However, should there be any problem encountered in the operation of the MC-COS, identify where the trouble occurs and consult the troubleshooting guide below. When a problem arises, the trouble may lie in the MC-COS drive section, pressure reducing valve (including separator/trap) or the controller.

Identifying Problem Areas

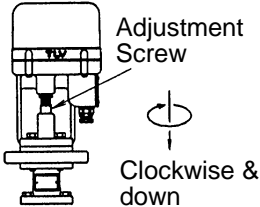
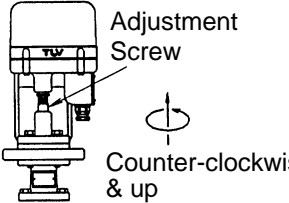
1. Set the operation mode to MANUAL (MAN) on the controller connected to the MC-COS. This is to enable the operation signal to the drive section to be changed to any value.
2. Set the control output on the controller to any value. Check to make sure that the pressure adjustment screw in the drive section is stopped completely and is not hunting (the secondary steam pressure is stabilized).
3. Increase the control output on the controller. Check to make sure that, as viewed from above, the pressure adjustment screw rotates clockwise while moving downward, and that the secondary steam pressure increases.
 
4. In the same manner, decrease the control output on the controller. Check to make sure that, as viewed from above, the pressure adjustment screw rotates counterclockwise while moving upward, and that the secondary steam pressure decreases.
 
5. If the process in steps 2. – 4. above reveals that:
 - The pressure adjustment screw is operating normally but the secondary steam pressure does not change, then see the “Pressure Reducing Valve Troubleshooting” section.
 - The pressure adjustment screw does not rotate, then go on to the next step.

6. Check to see whether the proper line voltage and control signals are being input to the terminals in the drive section terminal box. With the proper wiring, the values should be within the following ranges:

- Line voltage (between terminals 1 and 2): If the value is outside the range of 90 - 264 V AC, enter the proper line voltage.
- Control signal (between terminals 4 and 5): 0.8 – 5.2 V DC.

NOTE: When the control signal from the controller is:

0% – the value should be approx. 1 V DC

50% – the value should be approx. 3 V DC

100% – the value should be approx. 5 V DC

Points in between those above will vary proportionally.

If the value is outside this range, check for disconnected wiring or controller malfunction. If the voltage is correct but the drive section does still not rotate, there may be a malfunction in the drive unit. Refer to “Drive Section Troubleshooting” and take appropriate measures.

7. Turn OFF the power to the drive section.

8. Using a wrench, turn the adjustment screw slowly. Be careful not to apply excessive force.
9. If the adjustment screw cannot be turned by hand or if it requires more than 10 N·m (7 lbf·ft) torque to do so, contact a TLV serviceworker.

10. Check to make sure that the secondary steam pressure increases when, as seen from above, the adjustment screw has been turned clockwise.

11. Check to make sure that the secondary steam pressure decreases when, as seen from above, the adjustment screw has been turned counterclockwise.

12. If the secondary steam pressure does not change in steps 10. and 11. above, see the “Pressure Reducing Valve Troubleshooting” section.

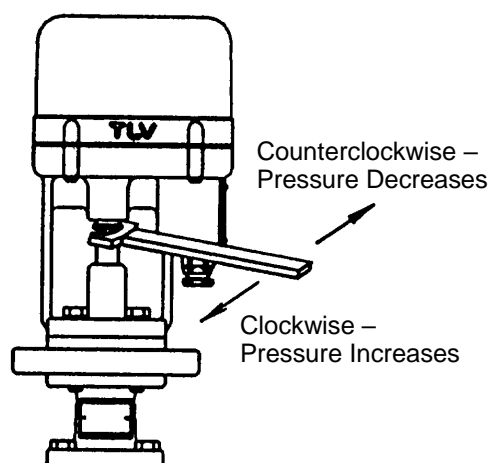
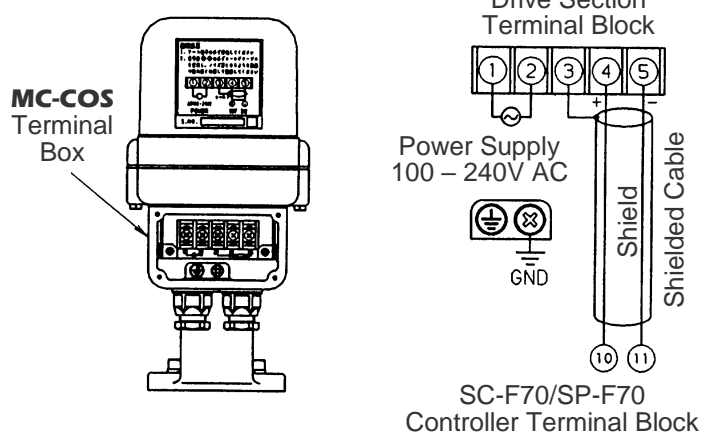

Pressure Reducing Valve Troubleshooting

Problems are classified as follows:

1. The secondary pressure does not increase.
2. The secondary pressure cannot be adjusted or increases abnormally.
3. Hunting occurs (fluctuation of the secondary pressure).
4. Chattering occurs (a heavy mechanical noise).
5. Steam leaks from the steam trap or condensate is not discharged.
6. Abnormal noises.

Major causes for the above problems are usage under non-specified conditions (out of specification), insufficient pressure or flow rate, and clogs by dirt and scale. Be sure to check for these causes.

To ensure performance for a long period of time, it is recommended that the Safety Considerations and Adjustment sections be reviewed.

Problem	Symptom	Cause	Remedy
Secondary pressure does not rise	The body is not warm	No steam is being supplied or the inlet valve is closed	Check upstream steam pipeline
	The body is warm, but the pressure does not increase	The screens or strainer are clogged	Clean or blow down
Secondary pressure cannot be adjusted or increases abnormally	The motor is not turning over	The controller is malfunctioning	Check, repair
	Adjustment is difficult, and set pressure varies	The pilot screen is clogged	Clean
		There is insufficient steam flow	Check the flow; replace the MC-COS if necessary
		The piston is clogged with dirt	Clean; check the piston ring
		The piston ring is worn	Replace with a new piston ring
		The small hole on the piston is clogged	Clean
		There is a dirt build-up on the sliding surfaces of the pilot valve, piston or main valve	Clean
		Flow rate exceeds rated flow rate	Check the flow rate; replace with a larger size
		The adjustment screw has seized	Replace with a new adjustment screw
		The diaphragm is distorted or damaged	Replace with a new diaphragm
		There is fluctuation in steam consumption	Check flow rate; replace the MC-COS if necessary
The selected model is inappropriate for the service conditions (specifications)	Check the model selection; replace the MC-COS if necessary		

Continued on the next page

Problem	Symptom	Cause	Remedy
Secondary pressure cannot be adjusted or increases abnormally (continued)	Upon closing secondary side valves, secondary pressure abruptly rises as high as primary pressure	The bypass valve is leaking	Check; clean; replace with a new valve if necessary
		The pilot valve seat or main valve seat is damaged	Replace damaged parts with new
		There is a build-up of dirt on the pilot valve seat or main valve seat	Clean; align; replace if necessary
Hunting or chattering occurs	Occurs at low steam demand	It is being operated below the lower flow rate limit	Check the volume of steam supply, replace with a smaller diameter valve
	Hunting never stops	There is too high a reduction ratio (operated at below 10% of the primary pressure)	Use a two-stage reduction arrangement
		The selected model is inappropriate for the service conditions (specifications)	Check the model selection, replace the MC-COS if necessary
	Chattering never stops	Condensate is contained, or the trap is blocked	Check the trap; check the piping
The selected model is inappropriate for the service conditions (specifications)		Check the model selection, replace the MC-COS if necessary	
Abnormal noises	Makes a high-pitched noise	There is too high a reduction ratio, the flow is too great, or there is a high-speed open / close valve nearby	Use two-stage reduction Check the flow rate, use a larger size valve Install the valve as far away as possible
Faulty steam trap	Steam is blowing	There is a build-up of dirt on the trap valve seat or at the float base	Clean
		The body is installed tilted	Check the piping
		The float is deformed	Check for water hammer; replace with a new float
		There is vibration in the piping	Secure the piping
	No condensate is discharged	The primary pressure exceeds the trap valve seat maximum working pressure (exceeds operating pressure range of MC-COS)	Ensure MC-COS is used within the recommended pressure range
		Water is inside the float	Replace with a new float
		The outlet piping is clogged	Check the piping; clean
	The trap valve seat is clogged	Clean or replace with a new trap valve seat	

Drive Section Troubleshooting

The drive section has a built-in microcomputer with a self-diagnosis function for malfunctions of the drive section. Identify the cause of the trouble with the following procedures.

1. Turn OFF the power supply to the drive section.
2. Remove the motor cover (blue housing) of the drive section.
3. Confirm the position of the 4 LEDs (LE1 – 4) and the switch (PS1) mounted on the board from the terminal block side.
4. Turn ON the power supply to the drive section, being careful not to be electrocuted or cause a short out since the electrical circuit is exposed.
5. Press the PS1 switch. Confirm the lighting status of the 4 LEDs. Different LEDs light up depending on the malfunction. Refer to the table on the next page and take proper measures.

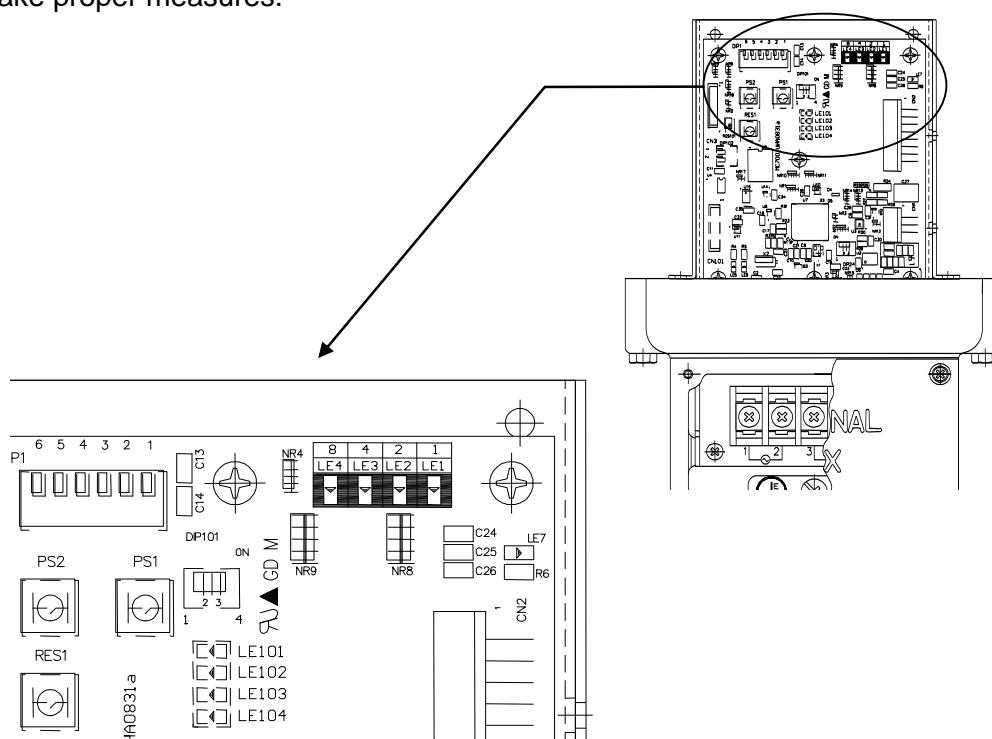

Malfunctions and Countermeasures			
○:OFF ●:ON			
LE 4, 3, 2, 1	Malfunction Details	Performance of the actuator when abnormality occurs	Remedy
○○○○	No malfunction is detected (All LEDs are normally OFF)	Continuous operation	
○○○●	Operation signal input error	Continuous operation	Operation input signal is abnormal. Make sure that there is no abnormality with the controller and the cable for the operation input signal.
●○○○	Temperature in the actuator is abnormal	Continuous operation	Make sure that the temperature around the drive section is within the specification range (0 to 50 °C (32 – 122 F°).
○○●●	Motor is overloaded	Motor shuts down, then keeps rebooting after a few seconds.	Motor is abnormally overloaded. Contact TLV.
○●○●	Low motor load (reducer gear wear, motor slippage)	Continuous operation	Possibility of abnormal wear of the gear in the reducer. Contact TLV.
●○○●	Potentiometer signal error	Stops when malfunction occurs	Potentiometer is abnormal. Contact TLV.
●○●○	Initialization error	Stops when malfunction occurs	If the same phenomenon occurs after switching the power OFF and ON, contact TLV.
●●○○	E ² PROM Store Error	Stops when malfunction occurs	
○●●●	Motor drive power voltage is abnormal	Continuous operation	Possible abnormality of the power supply circuit. Contact TLV.
●○●●	CPU Error	Stops when malfunction occurs	If the same phenomenon occurs after switching the power OFF and ON, contact TLV.
●●●○	External clock stops	Continuous operation using internal clock	Possible abnormality of the internal circuit.
●●●●	Mode Setting Error	Stops	Contact TLV.
○○●○	(spare)	Continuous operation	
○●○○	(spare)	Continuous operation	
○●●○	(spare)	Continuous operation	
●●○●	(spare)	Continuous operation	

TLV EXPRESS LIMITED WARRANTY

Subject to the limitations set forth below, TLV CO., LTD., a Japanese corporation (“**TLV**”), warrants that products which are sold by it, TLV International Inc. (“**TII**”) or one of its group companies excluding TLV Corporation (a corporation of the United States of America), (hereinafter the “**Products**”) are designed and manufactured by TLV, conform to the specifications published by TLV for the corresponding part numbers (the “**Specifications**”) and are free from defective workmanship and materials. The party from whom the Products were purchased shall be known hereinafter as the “**Seller**”. With regard to products or components manufactured by unrelated third parties (the “**Components**”), TLV provides no warranty other than the warranty from the third party manufacturer(s), if any.

Exceptions to Warranty

This warranty does not cover defects or failures caused by:

1. improper shipping, installation, use, handling, etc., by persons other than TLV, TII or TLV group company personnel, or service representatives authorized by TLV; or
2. dirt, scale or rust, etc.; or
3. improper disassembly and reassembly, or inadequate inspection and maintenance by persons other than TLV or TLV group company personnel, or service representatives authorized by TLV; or
4. disasters or forces of nature or Acts of God; or
5. abuse, abnormal use, accidents or any other cause beyond the control of TLV, TII or TLV group companies; or
6. improper storage, maintenance or repair; or
7. operation of the Products not in accordance with instructions issued with the Products or with accepted industry practices; or
8. use for a purpose or in a manner for which the Products were not intended; or
9. use of the Products in a manner inconsistent with the Specifications; or
10. use of the Products with Hazardous Fluids (fluids other than steam, air, water, nitrogen, carbon dioxide and inert gases (helium, neon, argon, krypton, xenon and radon)); or
11. failure to follow the instructions contained in the TLV Instruction Manual for the Product.

Duration of Warranty

This warranty is effective for a period of one (1) year after delivery of Products to the first end user. Notwithstanding the foregoing, asserting a claim under this warranty must be brought within three (3) years after the date of delivery to the initial buyer if not sold initially to the first end user.

ANY IMPLIED WARRANTIES NOT NEGATED HEREBY WHICH MAY ARISE BY OPERATION OF LAW, INCLUDING THE IMPLIED WARRANTIES OF MERCHANTABILITY AND FITNESS FOR A PARTICULAR PURPOSE AND ANY EXPRESS WARRANTIES NOT NEGATED HEREBY, ARE GIVEN SOLELY TO THE INITIAL BUYER AND ARE LIMITED IN DURATION TO ONE (1) YEAR FROM THE DATE OF SHIPMENT BY THE SELLER.

Exclusive Remedy

THE EXCLUSIVE REMEDY UNDER THIS WARRANTY, UNDER ANY EXPRESS WARRANTY OR UNDER ANY IMPLIED WARRANTIES NOT NEGATED HEREBY (INCLUDING THE IMPLIED WARRANTIES OF MERCHANTABILITY AND FITNESS FOR A PARTICULAR PURPOSE), IS **REPLACEMENT**; PROVIDED: (a) THE CLAIMED DEFECT IS REPORTED TO

THE SELLER IN WRITING WITHIN THE WARRANTY PERIOD, INCLUDING A DETAILED WRITTEN DESCRIPTION OF THE CLAIMED DEFECT AND HOW AND WHEN THE CLAIMED DEFECTIVE PRODUCT WAS USED; AND (b) THE CLAIMED DEFECTIVE PRODUCT AND A COPY OF THE PURCHASE INVOICE IS RETURNED TO THE SELLER, FREIGHT AND TRANSPORTATION COSTS PREPAID, UNDER A RETURN MATERIAL AUTHORIZATION AND TRACKING NUMBER ISSUED BY THE SELLER. ALL LABOR COSTS, SHIPPING COSTS, AND TRANSPORTATION COSTS ASSOCIATED WITH THE RETURN OR REPLACEMENT OF THE CLAIMED DEFECTIVE PRODUCT ARE SOLELY THE RESPONSIBILITY OF BUYER OR THE FIRST END USER. THE SELLER RESERVES THE RIGHT TO INSPECT ON THE FIRST END USER'S SITE ANY PRODUCTS CLAIMED TO BE DEFECTIVE BEFORE ISSUING A RETURN MATERIAL AUTHORIZATION. SHOULD SUCH INSPECTION REVEAL, IN THE SELLER'S REASONABLE DISCRETION, THAT THE CLAIMED DEFECT IS NOT COVERED BY THIS WARRANTY, THE PARTY ASSERTING THIS WARRANTY SHALL PAY THE SELLER FOR THE TIME AND EXPENSES RELATED TO SUCH ON-SITE INSPECTION.

Exclusion of Consequential and Incidental Damages

IT IS SPECIFICALLY ACKNOWLEDGED THAT THIS WARRANTY, ANY OTHER EXPRESS WARRANTY NOT NEGATED HEREBY, AND ANY IMPLIED WARRANTY NOT NEGATED HEREBY, INCLUDING THE IMPLIED WARRANTIES OF MERCHANTABILITY AND FITNESS FOR A PARTICULAR PURPOSE, DO NOT COVER, AND NEITHER TLV, TII NOR ITS TLV GROUP COMPANIES WILL IN ANY EVENT BE LIABLE FOR, INCIDENTAL OR CONSEQUENTIAL DAMAGES, INCLUDING, BUT NOT LIMITED TO LOST PROFITS, THE COST OF DISASSEMBLY AND SHIPMENT OF THE DEFECTIVE PRODUCT, INJURY TO OTHER PROPERTY, DAMAGE TO BUYER'S OR THE FIRST END USER'S PRODUCT, DAMAGE TO BUYER'S OR THE FIRST END USER'S PROCESSES, LOSS OF USE, OR OTHER COMMERCIAL LOSSES. WHERE, DUE TO OPERATION OF LAW, CONSEQUENTIAL AND INCIDENTAL DAMAGES UNDER THIS WARRANTY, UNDER ANY OTHER EXPRESS WARRANTY NOT NEGATED HEREBY OR UNDER ANY IMPLIED WARRANTY NOT NEGATED HEREBY (INCLUDING THE IMPLIED WARRANTIES OF MERCHANTABILITY AND FITNESS FOR A PARTICULAR PURPOSE) CANNOT BE EXCLUDED, SUCH DAMAGES ARE EXPRESSLY LIMITED IN AMOUNT TO THE PURCHASE PRICE OF THE DEFECTIVE PRODUCT. THIS EXCLUSION OF CONSEQUENTIAL AND INCIDENTAL DAMAGES, AND THE PROVISION OF THIS WARRANTY LIMITING REMEDIES HEREUNDER TO REPLACEMENT, ARE INDEPENDENT PROVISIONS, AND ANY DETERMINATION THAT THE LIMITATION OF REMEDIES FAILS OF ITS ESSENTIAL PURPOSE OR ANY OTHER DETERMINATION THAT EITHER OF THE ABOVE REMEDIES IS UNENFORCEABLE, SHALL NOT BE CONSTRUED TO MAKE THE OTHER PROVISIONS UNENFORCEABLE.

Exclusion of Other Warranties

THIS WARRANTY IS IN LIEU OF ALL OTHER WARRANTIES, EXPRESS OR IMPLIED, AND ALL OTHER WARRANTIES, INCLUDING BUT NOT LIMITED TO THE IMPLIED WARRANTIES OF MERCHANTABILITY AND FITNESS FOR A PARTICULAR PURPOSE, ARE EXPRESSLY DISCLAIMED.

Severability

Any provision of this warranty which is invalid, prohibited or unenforceable in any jurisdiction shall, as to such jurisdiction, be ineffective to the extent of such invalidity, prohibition or unenforceability without invalidating the remaining provisions hereof, and any such invalidity, prohibition or unenforceability in any such jurisdiction shall not invalidate or render unenforceable such provision in any other jurisdiction.

Service

For Service or Technical Assistance: Contact your TLV representative or your regional TLV office.

In Europe:

TLV EURO ENGINEERING GmbH

Daimler-Benz-Straße 16-18, 74915 Waibstadt, **Germany**

Tel: [49]-(0)7263-9150-0
Fax: [49]-(0)7263-9150-50

TLV EURO ENGINEERING UK LTD.

Units 7 & 8, Furlong Business Park, Bishops Cleeve, Gloucestershire GL52 8TW, **U.K.**

Tel: [44]-(0)1242-227223
Fax: [44]-(0)1242-223077

TLV EURO ENGINEERING FRANCE SARL

Parc d'Ariane 2, bât. C, 290 rue Ferdinand Perrier, 69800 Saint Priest, **France**

Tel: [33]-(0)4-72482222
Fax: [33]-(0)4-72482220

In North America:

TLV CORPORATION

13901 South Lakes Drive, Charlotte, NC 28273-6790, **U.S.A.**

Tel: [1]-704-597-9070
Fax: [1]-704-583-1610

In Mexico and Latin America:

TLV ENGINEERING S. A. DE C.V.

Av. Jesús del Monte 39-B-1001, Col. Hda. de las Palmas, Huixquilucan, Edo. de México, 52763, **Mexico**

Tel: [52]-55-5359-7949
Fax: [52]-55-5359-7585

In Oceania:

TLV PTY LIMITED

Unit 8, 137-145 Rooks Road, Nunawading, Victoria 3131, **Australia**

Tel: [61]-(0)3-9873 5610
Fax: [61]-(0)3-9873 5010

In East Asia:

TLV PTE LTD

36 Kaki Bukit Place, #02-01/02, **Singapore** 416214

Tel: [65]-6747 4600
Fax: [65]-6742 0345

TLV SHANGHAI CO., LTD.

Room 5406, No. 103 Cao Bao Road, Shanghai, **China** 200233

Tel: [86]-(0)21-6482-8622
Fax: [86]-(0)21-6482-8623

TLV ENGINEERING SDN. BHD.

No.16, Jalan MJ14, Taman Industri Meranti Jaya, 47120 Puchong, Selangor, **Malaysia**

Tel: [60]-3-8065-2928
Fax: [60]-3-8065-2923

TLV PRIVATE LIMITED

252/94 (K-L) 17th Floor, Muang Thai-Phatra Complex Tower B, Rachadaphisek Road, Huaykwang, Bangkok 10310, **Thailand**

Tel: [66]-2-693-3799
Fax: [66]-2-693-3979

TLV INC.

#302-1 Bundang Technopark B, 723 Pangyo-ro, Bundang, Seongnam, Gyeonggi, 13511, **Korea**

Tel: [82]-(0)31-726-2105
Fax: [82]-(0)31-726-2195

In the Middle East:

TLV ENGINEERING FZCO

Building 2W, No. M002, PO Box 371684, Dubai Airport Free Zone, Dubai, **UAE**

Email: sales-me@tlv.co.jp

In Other Countries:

TLV INTERNATIONAL, INC.

881 Nagasuna, Noguchi, Kakogawa, Hyogo 675-8511, **Japan**

Tel: [81]-(0)79-427-1818
Fax: [81]-(0)79-425-1167

Manufacturer:

TLV CO., LTD.

881 Nagasuna, Noguchi, Kakogawa, Hyogo 675-8511, **Japan**

Tel: [81]-(0)79-422-1122
Fax: [81]-(0)79-422-0112