



Manufacturer

TLV CO., LTD.

Kakogawa, Japan

is approved by EBCA Ltd. to ISO 9001/14001



Instruction Manual

Cyclone Separator Trap (for Air) **DC3A-H**

Copyright © 2021 by TLV CO., LTD.

All rights reserved

Contents

Introduction	1
Safety Considerations	2
Specifications	4
Configuration	5
Installation	6
Maintenance	7
Disassembly/Reassembly	8
Troubleshooting	11
TLV EXPRESS LIMITED WARRANTY	12
Service	14

Introduction

Thank you for purchasing the TLV cyclone separator trap for air.

This product has been thoroughly inspected before being shipped from the factory. When the product is delivered, before doing anything else, check the specifications and external appearance to make sure nothing is out of the ordinary. Also be sure to read this manual carefully before use and follow the instructions to be sure of using the product properly.

This cyclone separator trap features a built-in free float air trap and uses centrifugal force to separate condensate from air. The combination of separator and built-in trap makes this product suitable for use in locations where a separator would be installed together with a trap.

If detailed instructions for the special order specifications or options are not contained in this manual, please contact TLV for full details.

This instruction manual is intended for use with the model(s) listed on the front cover. It is necessary not only for installation but for subsequent maintenance, disassembly/reassembly and troubleshooting. Please keep it in a safe place for future reference.

Safety Considerations

- Read this section carefully before use and be sure to follow the instructions.
- Installation, inspection, maintenance, repairs, disassembly, adjustment and valve opening/closing should be carried out only by trained maintenance personnel.
- The precautions listed in this manual are designed to ensure safety and prevent equipment damage and personal injury. For situations that may occur as a result of erroneous handling, three different types of cautionary items are used to indicate the degree of urgency and the scale of potential damage and danger: DANGER, WARNING and CAUTION.
- The three types of cautionary items above are very important for safety: be sure to observe all of them as they relate to installation, use, maintenance, and repair. Furthermore, TLV accepts no responsibility for any accidents or damage occurring as a result of failure to observe these precautions.



Symbols

	Indicates a DANGER, WARNING or CAUTION item.
	Indicates an urgent situation which poses a threat of death or serious injury
	Indicates that there is a potential threat of death or serious injury
	Indicates that there is a possibility of injury or equipment/product damage
	<p>DO NOT use for toxic, flammable or otherwise hazardous fluids.</p> <p>This product is a separator trap for air that separates and discharges condensate from air piping systems. Use only for air and/or air condensate. This product is for intended use only. Improper use may result in such hazards as damage to the product or malfunctions that may lead to serious accidents.</p>
	<p>NEVER apply direct heat to the float.</p> <p>The float may explode due to increased internal pressure, causing accidents leading to serious injury or damage to property and equipment.</p>
	<p>Install properly and DO NOT use this product outside the recommended operating pressure, temperature and other specification ranges.</p> <p>Improper use may result in such hazards as damage to the product or malfunctions that may lead to serious accidents. Local regulations may restrict the use of this product to below the conditions quoted.</p>
	<p>DO NOT use the product in excess of the maximum operating pressure differential.</p> <p>Such use could make discharge impossible (blocked).</p>

Continued on the next page

 CAUTION	<p>Use hoisting equipment for heavy objects (weighing approximately 20 kg (44 lb) or more). Failure to do so may result in back strain or other injury if the object should fall.</p>
	<p>Take measures to prevent people from coming into direct contact with product outlets. Failure to do so may result in burns or other injury from the discharge of fluids.</p>
	<p>When disassembling or removing the product, wait until the internal pressure equals atmospheric pressure and the surface of the product has cooled to room temperature. Disassembling or removing the product when it is hot or under pressure may lead to discharge of fluids, causing burns, other injuries or damage.</p>
	<p>Be sure to use only the recommended components when repairing the product, and NEVER attempt to modify the product in any way. Failure to observe these precautions may result in damage to the product and burns or other injury due to malfunction or the discharge of fluids.</p>
	<p>Do not use excessive force when connecting threaded pipes to the product. Over-tightening may cause breakage leading to fluid discharge, which may cause burns or other injury.</p>
	<p>Use only under conditions in which no freeze-up will occur. Freezing may damage the product, leading to fluid discharge, which may cause burns or other injury.</p>

Specifications

 WARNING	DO NOT use for toxic, flammable or otherwise hazardous fluids. This product is a separator trap for air that separates and discharges condensate from air piping systems. Use only for air and/or air condensate. This product is for intended use only. Improper use may result in such hazards as damage to the product or malfunctions that may lead to serious accidents.
 CAUTION	Install properly and DO NOT use this product outside the recommended operating pressure, temperature and other specification ranges. Improper use may result in such hazards as damage to the product or malfunctions that may lead to serious accidents. Local regulations may restrict the use of this product to below the conditions quoted. DO NOT use the product in excess of the maximum operating pressure differential: such use could make discharge impossible (blocked). Use only under conditions in which no freeze-up will occur. Freezing may damage the product, leading to fluid discharge, which may cause burns or other injury.

Refer to the product nameplate for detailed specifications.

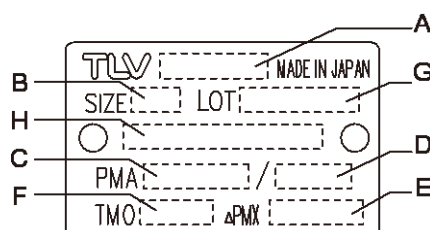

A	Model
B	Nominal Diameter
C	Maximum Allowable Pressure (PMA)
D	Maximum Allowable Temperature (TMA)*
E	Maximum Differential Pressure
F	Maximum Operating Temperature (TMO)
G	Production Lot No.
H	Valve No.**

* Maximum allowable pressure (PMA) and maximum allowable temperature (TMA) are PRESSURE SHELL DESIGN CONDITIONS, **NOT** OPERATING CONDITIONS.

** Valve No. is displayed for products with options. This item is omitted from the nameplate when there are no options.

Configuration

15 – 50 mm (1/2 – 2 in)

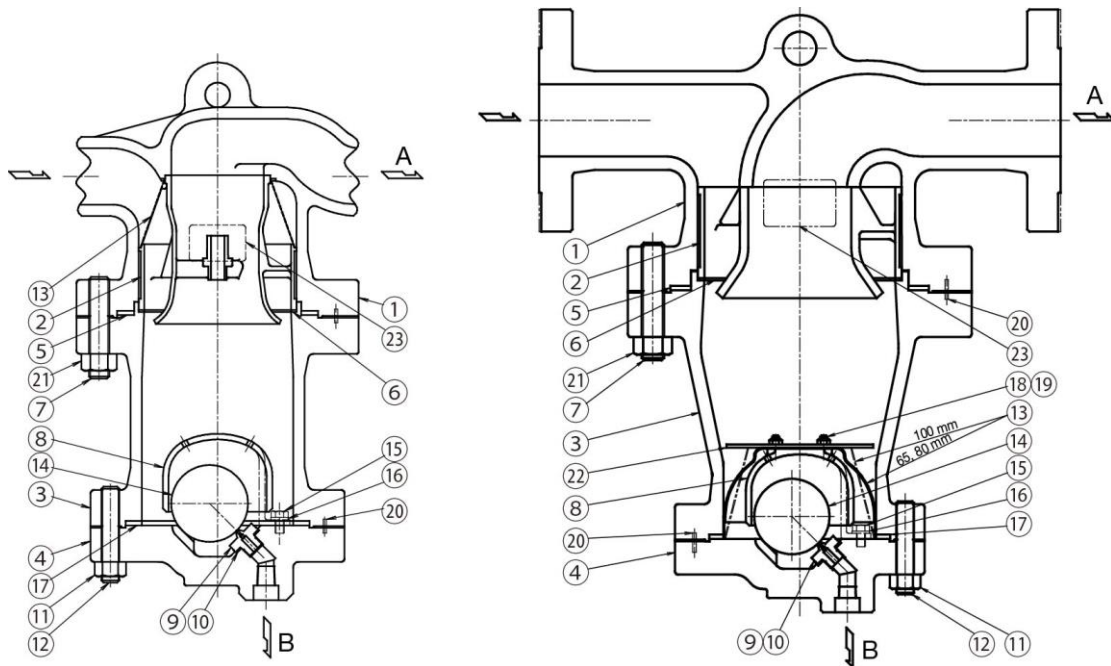

65 – 100 mm (2 1/2 – 4 in)



No.	Name
1	Body
2	Separator
3	Separator Body
4	Trap Cover
5	Body Gasket
6	Wave Spring
7	Body Bolt
8	Float Cover
9	Trap Valve Seat
10	Valve Seat Gasket
11	Trap Cover Nut
12	Trap Cover Bolt
13	Screen
14	Float
15	Float Cover Bolt
16	Spring Washer
17	Trap Cover Gasket
18	Baffle Bolt
19	Baffle Nut
20	Guide Pin
21	Body Nut
22	Baffle
23	Nameplate

A: Separator Outlet
B: Air Trap Outlet

Installation

 WARNING	<p>DO NOT use for toxic, flammable or otherwise hazardous fluids. This product is a separator trap for air that separates and discharges condensate from air piping systems. Use only for air and/or air condensate. This product is for intended use only. Improper use may result in such hazards as damage to the product or malfunctions that may lead to serious accidents.</p>
 CAUTION	<p>Install properly and DO NOT use this product outside the recommended operating pressure, temperature and other specification ranges. Improper use may result in such hazards as damage to the product or malfunctions that may lead to serious accidents. Local regulations may restrict the use of this product to below the conditions quoted.</p>
	<p>Use hoisting equipment for heavy objects (weighing approximately 20 kg (44 lb) or more). Failure to do so may result in back strain or other injury if the object should fall.</p>
	<p>Take measures to prevent people from coming into direct contact with product outlets. Failure to do so may result in burns or other injury from the discharge of fluids.</p>
	<p>Do not use excessive force when connecting threaded pipes to the product. Over-tightening may cause breakage leading to fluid discharge, which may cause burns or other injury.</p>

Installation, inspection, maintenance, repairs, disassembly, adjustment and valve opening/closing should be carried out only by trained maintenance personnel.

1. Before installation, be sure to remove all protective seals.
2. Before installing the product, blow out the inlet piping to remove any piping scraps, dirt and oil. Close the inlet valve after blowdown.
3. Install the product at the point on the piping where the separation of condensate will have the greatest effect on efficiency. For example, on an air main or branch at the inlet of equipment requiring high-quality dry air.
4. Install the product so the arrow on the product is pointing in the direction of flow.
5. The product should be inclined no more than 10° horizontally and front-to-back.
6. Install a separator outlet valve and separator outlet piping, and air trap outlet fittings and air trap outlet piping.
7. To facilitate inspection and maintenance, install a union at the air trap outlet and ensure that there is sufficient space for maintenance.
8. Open the inlet valve and outlet valves and check to make sure that the product functions properly.

If there is a problem, determine the cause using the “Troubleshooting” section in this manual.

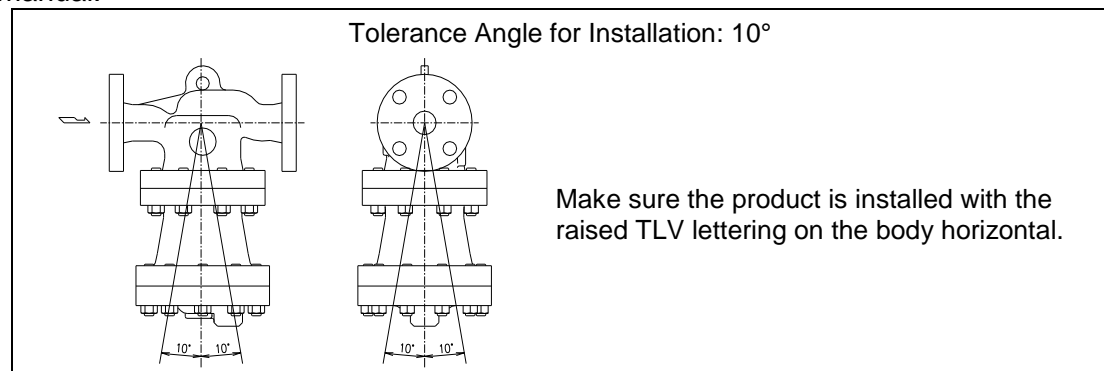

Maintenance

 CAUTION	Take measures to prevent people from coming into direct contact with product outlets. Failure to do so may result in burns or other injury from the discharge of fluids.
	Be sure to use only the recommended components when repairing the product, and NEVER attempt to modify the product in any way. Failure to observe these precautions may result in damage to the product and burns or other injury due to malfunction or the discharge of fluids.

Operational Check

A visual inspection of the following items should be done on a daily basis to determine whether the product is operating properly or has failed. Periodically (at least biannually) the operation should also be checked by using diagnostic equipment, such as a stethoscope or thermometer. (Installation, inspection, maintenance, repairs, disassembly, adjustment and valve opening/closing should be carried out only by trained maintenance personnel.)

Check to see if air is flowing from the separator outlet. Check all flow meters and check the differential pressure.

If there is insufficient flow or differential pressure is too large, disassemble and check for clogging of the screen.

If the product should fail, it may cause damage to piping and equipment, resulting in faulty or low quality products or losses due to air leakage.

Trap Operational Check



Normal	:	Condensate is discharged continuously from the trap, and nothing but condensate is discharged.
Blocked (Discharge Impossible)	:	No condensate is discharged from the trap outlet.
Blowing	:	Air continuously flows from the trap outlet.
Leakage	:	Air is discharged through the trap outlet together with the condensate.

Parts Inspection

When parts have been removed, or during periodic inspections, use the following table to inspect the parts and replace any that are found to be defective.

Procedure	
Screen:	Check for clogging or corrosion
Gaskets:	Check for warping or damage
Float:	Check for scratches or dents
Trap Valve Seat:	Check for wear or scratches
Body Interior:	Check for build-up

Disassembly/Reassembly

 WARNING	NEVER apply direct heat to the float. The float may explode due to increased internal pressure, causing accidents leading to serious injury or damage to property and equipment.
 CAUTION	Use hoisting equipment for heavy objects (weighing approximately 20 kg (44 lb) or more). Failure to do so may result in back strain or other injury if the object should fall. When disassembling or removing the product, wait until the internal pressure equals atmospheric pressure and the surface of the product has cooled to room temperature. Disassembling or removing the product when it is hot or under pressure may lead to discharge of fluids, causing burns, other injuries or damage.

Use the following procedures to remove components. Use the same procedures in reverse to reassemble. (Installation, inspection, maintenance, repairs, disassembly, adjustment and valve opening/closing should be carried out only by trained maintenance personnel.)

Removing/Reattaching the Trap Cover

Part	During Disassembly	During Reassembly
Trap Cover Nut 11	Remove with a socket wrench	Consult the table of tightening torques and tighten to the proper torque
Trap Cover 4	Remove the trap cover by pulling it down, being careful not to scratch the seating surface	Make sure there are no pieces of the old gasket left on the sealing surfaces of the separator body and trap cover, align the guide pin on the separator body with the guide pin hole on the trap cover and reattach
Trap Cover Gasket 17	Remove the gasket and clean sealing surfaces	Replace with a new gasket

Removing/Reinserting Parts inside the Trap Cover

Part	During Disassembly	During Reassembly
Baffle Nut 19 65 – 100 mm (2½ – 4 in)	Remove with a socket wrench	Consult the table of tightening torques and tighten to the proper torque
Baffle 22 65 – 100 mm (2½ – 4 in)	Lift off of bolts	Align with bolts and set on float cover
Screen 13 65 – 100 mm (2½ – 4 in)	Remove, being careful not to bend	Place on top of the separator, being careful not to bend
Float Cover Bolt 15, Spring Washer 16	Remove with a socket wrench	Consult the table of tightening torques and tighten to the proper torque
Float Cover 8	Remove by lifting up and off	Place it into position
Float 14	Remove, being careful not to scratch the polished surface	Insert, being careful not to scratch the polished surface
Trap Valve Seat 9	Remove with a socket wrench	Consult the table of tightening torques and tighten to the proper torque
Valve Seat Gasket 10	Remove, being careful not to scratch the surfaces	Replace with a new gasket

Separating/Reattaching Body and Separator Body

Part	During Disassembly	During Reassembly
Body Nut 21	Remove with a wrench	Consult the table of tightening torques and tighten to the proper torque
Separator Body 3	Pull down and out from the body, being careful not to let the separator and wave spring fall as they come out with the separator body	Make sure there are no pieces of the old gasket left on the sealing surfaces of the separator body and body, align the guide pin on the separator body with the guide pin hole on the body and reattach
Separator 2	Remove when detaching the separator body	Insert into the groove in the separator body
Wave Spring 6	Remove from its groove	Insert into the groove
Screen 13 15 – 50 mm ($\frac{1}{2}$ – 2 in)	Remove, being careful not to bend	Place on top of the separator, being careful not to bend
Body Gasket 5	Remove, being careful not to scratch the sealing surfaces	Replace with a new gasket

Table of Tightening Torques

Part	Size		Torque		Distance Across Flats	
	mm	(in)	N·m	(lb·ft)	mm	(in)
Body Nut 21	15 - 40	($1\frac{1}{2}$ – $1\frac{1}{2}$)	160	(115)	24	($\frac{15}{16}$)
	50	(2)	180	(130)	27	($1\frac{1}{16}$)
	65, 80	($2\frac{1}{2}$, 3)	200	(150)	30	($1\frac{3}{16}$)
	100	(4)	270	(199)	32	($1\frac{1}{4}$)
Trap Cover Nut 11	15 - 80	($\frac{1}{2}$ – 3)	160	(115)	24	($\frac{15}{16}$)
	100	(4)	200	(150)	30	($1\frac{3}{16}$)
Trap Valve Seat 9	15 - 80	($\frac{1}{2}$ – 3)	80	(59)	24	($\frac{15}{16}$)
	100	(4)	100	(73)	24	($\frac{15}{16}$)
Float Cover Bolt 15	15 - 100	($\frac{1}{2}$ – 4)	20	(15)	13	($\frac{1}{2}$)
Baffle Nut 19	65, 80	($2\frac{1}{2}$, 3)	10	(7)	10	($\frac{3}{8}$)
	100	(4)	20	(15)	13	($\frac{1}{2}$)

NOTE: -Coat all threaded portions with anti-seize. (1 N·m \approx 10 kg·cm)
 -If drawings or other special documentation were supplied for the product, any torque given there takes precedence over values shown here.

Exploded View

15 – 50 mm (1/2 – 2 in)

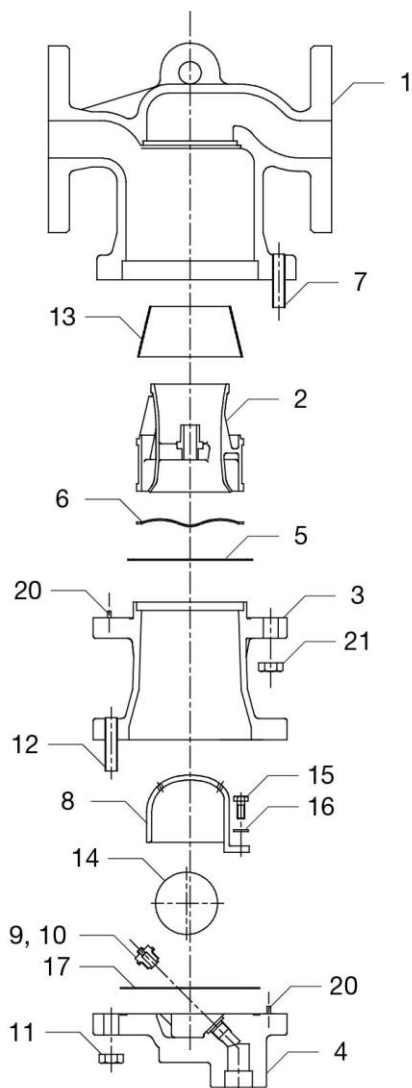

65 – 100 mm (2 1/2 – 4 in)

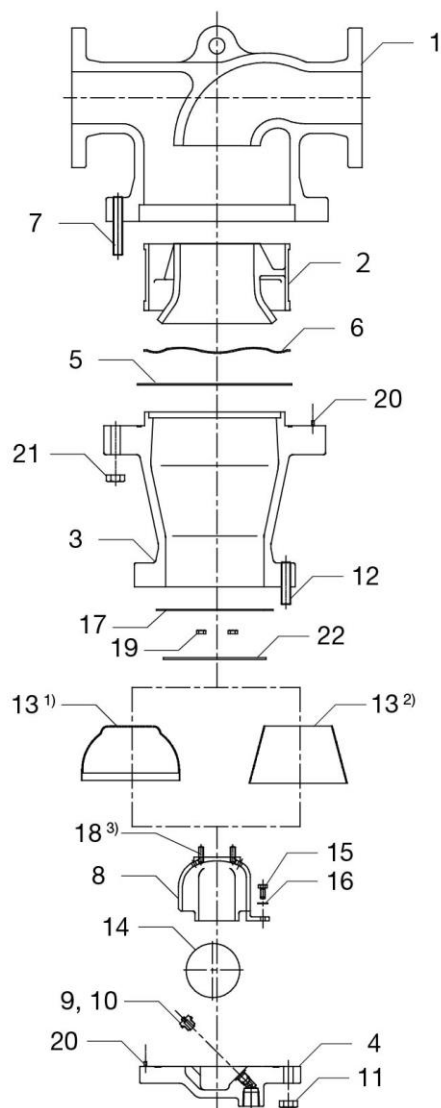



No.	Part Name	No.	Part Name
1	Body	12	Trap Cover Bolt
2	Separator	13	Screen
3	Separator Body	14	Float
4	Trap Cover	15	Float Cover Bolt
5	Body Gasket	16	Spring Washer
6	Wave Spring	17	Trap Cover Gasket
7	Body Bolt	18	Baffle Bolt
8	Float Cover	19	Baffle Nut
9	Trap Valve Seat	20	Guide Pin
10	Valve Seat Gasket	21	Body Nut
11	Trap Cover Nut	22	Baffle

¹⁾ 65, 80 mm (2 1/2, 3 in)

²⁾ 100 mm (4 in)

³⁾ Cannot be removed.

Troubleshooting

 WARNING	NEVER apply direct heat to the float. The float may explode due to increased internal pressure, causing accidents leading to serious injury or damage to property and equipment.
 CAUTION	When disassembling or removing the product, wait until the internal pressure equals atmospheric pressure and the surface of the product has cooled to room temperature. Disassembling or removing the product when it is hot or under pressure may lead to discharge of fluids, causing burns, other injuries or damage.

When the product fails to operate properly, use the following table to locate the cause and remedy.

Problem	Cause	Remedy
No condensate is discharged (blocked) or discharge is poor	The float is damaged or filled with condensate	Replace with a new float
	Trap valve seat port, screen or piping are clogged with rust or scale	Clean parts
	The product operating pressure exceeds the maximum specified pressure, or there is insufficient pressure differential between the trap inlet and outlet	Compare specifications and actual operating conditions
Air is discharged or leaks from the trap outlet (blowing) (air leakage)	Rust and scale have accumulated around the trap valve seat or beneath the float	Clean parts
	The trap valve seat is damaged	Replace with a new trap valve seat
	The float is deformed or coated with scale	Clean or replace with a new float
	The separator is installed above the maximum allowable inclination	Correct the installation
Air is leaking from sealing surfaces	Gasket deterioration or damage	Replace with a new gasket
	Improper tightening torques were used	Tighten to the proper torque
Water is mixed in with the air from the separator outlet	Air flow velocity is too high	Take steps necessary to lower the air flow velocity
	Review causes listed above in "No condensate is discharged..." section and follow the appropriate remedy	
Separator outlet pressure drops or desired flow rate is unachievable	The screen for 15 – 50 mm (1/2 – 2 in) is clogged with rust and scale	Clean or replace with a new screen

TLV EXPRESS LIMITED WARRANTY

Subject to the limitations set forth below, TLV CO., LTD., a Japanese corporation (“**TLV**”), warrants that products which are sold by it, TLV International Inc. (“**TII**”) or one of its group companies excluding TLV Corporation (a corporation of the United States of America), (hereinafter the “**Products**”) are designed and manufactured by TLV, conform to the specifications published by TLV for the corresponding part numbers (the “**Specifications**”) and are free from defective workmanship and materials. The party from whom the Products were purchased shall be known hereinafter as the “**Seller**”. With regard to products or components manufactured by unrelated third parties (the “**Components**”), TLV provides no warranty other than the warranty from the third party manufacturer(s), if any.

Exceptions to Warranty

This warranty does not cover defects or failures caused by:

1. improper shipping, installation, use, handling, etc., by persons other than TLV, TII or TLV group company personnel, or service representatives authorized by TLV; or
2. dirt, scale or rust, etc.; or
3. improper disassembly and reassembly, or inadequate inspection and maintenance by persons other than TLV or TLV group company personnel, or service representatives authorized by TLV; or
4. disasters or forces of nature or Acts of God; or
5. abuse, abnormal use, accidents or any other cause beyond the control of TLV, TII or TLV group companies; or
6. improper storage, maintenance or repair; or
7. operation of the Products not in accordance with instructions issued with the Products or with accepted industry practices; or
8. use for a purpose or in a manner for which the Products were not intended; or
9. use of the Products in a manner inconsistent with the Specifications; or
10. use of the Products with Hazardous Fluids (fluids other than steam, air, water, nitrogen, carbon dioxide and inert gases (helium, neon, argon, krypton, xenon and radon)); or
11. failure to follow the instructions contained in the TLV Instruction Manual for the Product.

Duration of Warranty

This warranty is effective for a period of one (1) year after delivery of Products to the first end user. Notwithstanding the foregoing, asserting a claim under this warranty must be brought within three (3) years after the date of delivery to the initial buyer if not sold initially to the first end user.

ANY IMPLIED WARRANTIES NOT NEGATED HEREBY WHICH MAY ARISE BY OPERATION OF LAW, INCLUDING THE IMPLIED WARRANTIES OF MERCHANTABILITY AND FITNESS FOR A PARTICULAR PURPOSE AND ANY EXPRESS WARRANTIES NOT NEGATED HEREBY, ARE GIVEN SOLELY TO THE INITIAL BUYER AND ARE LIMITED IN DURATION TO ONE (1) YEAR FROM THE DATE OF SHIPMENT BY THE SELLER.

Exclusive Remedy

THE EXCLUSIVE REMEDY UNDER THIS WARRANTY, UNDER ANY EXPRESS WARRANTY OR UNDER ANY IMPLIED WARRANTIES NOT NEGATED HEREBY (INCLUDING THE IMPLIED WARRANTIES OF MERCHANTABILITY AND FITNESS FOR A PARTICULAR PURPOSE), IS **REPLACEMENT**; PROVIDED: (a) THE CLAIMED DEFECT IS REPORTED TO THE SELLER IN WRITING WITHIN THE WARRANTY PERIOD, INCLUDING

A DETAILED WRITTEN DESCRIPTION OF THE CLAIMED DEFECT AND HOW AND WHEN THE CLAIMED DEFECTIVE PRODUCT WAS USED; AND (b) THE CLAIMED DEFECTIVE PRODUCT AND A COPY OF THE PURCHASE INVOICE IS RETURNED TO THE SELLER, FREIGHT AND TRANSPORTATION COSTS PREPAID, UNDER A RETURN MATERIAL AUTHORIZATION AND TRACKING NUMBER ISSUED BY THE SELLER. ALL LABOR COSTS, SHIPPING COSTS, AND TRANSPORTATION COSTS ASSOCIATED WITH THE RETURN OR REPLACEMENT OF THE CLAIMED DEFECTIVE PRODUCT ARE SOLELY THE RESPONSIBILITY OF BUYER OR THE FIRST END USER. THE SELLER RESERVES THE RIGHT TO INSPECT ON THE FIRST END USER'S SITE ANY PRODUCTS CLAIMED TO BE DEFECTIVE BEFORE ISSUING A RETURN MATERIAL AUTHORIZATION. SHOULD SUCH INSPECTION REVEAL, IN THE SELLER'S REASONABLE DISCRETION, THAT THE CLAIMED DEFECT IS NOT COVERED BY THIS WARRANTY, THE PARTY ASSERTING THIS WARRANTY SHALL PAY THE SELLER FOR THE TIME AND EXPENSES RELATED TO SUCH ON-SITE INSPECTION.

Exclusion of Consequential and Incidental Damages

IT IS SPECIFICALLY ACKNOWLEDGED THAT THIS WARRANTY, ANY OTHER EXPRESS WARRANTY NOT NEGATED HEREBY, AND ANY IMPLIED WARRANTY NOT NEGATED HEREBY, INCLUDING THE IMPLIED WARRANTIES OF MERCHANTABILITY AND FITNESS FOR A PARTICULAR PURPOSE, DO NOT COVER, AND NEITHER TLV, TII NOR ITS TLV GROUP COMPANIES WILL IN ANY EVENT BE LIABLE FOR, INCIDENTAL OR CONSEQUENTIAL DAMAGES, INCLUDING, BUT NOT LIMITED TO LOST PROFITS, THE COST OF DISASSEMBLY AND SHIPMENT OF THE DEFECTIVE PRODUCT, INJURY TO OTHER PROPERTY, DAMAGE TO BUYER'S OR THE FIRST END USER'S PRODUCT, DAMAGE TO BUYER'S OR THE FIRST END USER'S PROCESSES, LOSS OF USE, OR OTHER COMMERCIAL LOSSES. WHERE, DUE TO OPERATION OF LAW, CONSEQUENTIAL AND INCIDENTAL DAMAGES UNDER THIS WARRANTY, UNDER ANY OTHER EXPRESS WARRANTY NOT NEGATED HEREBY OR UNDER ANY IMPLIED WARRANTY NOT NEGATED HEREBY (INCLUDING THE IMPLIED WARRANTIES OF MERCHANTABILITY AND FITNESS FOR A PARTICULAR PURPOSE) CANNOT BE EXCLUDED, SUCH DAMAGES ARE EXPRESSLY LIMITED IN AMOUNT TO THE PURCHASE PRICE OF THE DEFECTIVE PRODUCT. THIS EXCLUSION OF CONSEQUENTIAL AND INCIDENTAL DAMAGES, AND THE PROVISION OF THIS WARRANTY LIMITING REMEDIES HEREUNDER TO REPLACEMENT, ARE INDEPENDENT PROVISIONS, AND ANY DETERMINATION THAT THE LIMITATION OF REMEDIES FAILS OF ITS ESSENTIAL PURPOSE OR ANY OTHER DETERMINATION THAT EITHER OF THE ABOVE REMEDIES IS UNENFORCEABLE, SHALL NOT BE CONSTRUED TO MAKE THE OTHER PROVISIONS UNENFORCEABLE.

Exclusion of Other Warranties

THIS WARRANTY IS IN LIEU OF ALL OTHER WARRANTIES, EXPRESS OR IMPLIED, AND ALL OTHER WARRANTIES, INCLUDING BUT NOT LIMITED TO THE IMPLIED WARRANTIES OF MERCHANTABILITY AND FITNESS FOR A PARTICULAR PURPOSE, ARE EXPRESSLY DISCLAIMED.

Severability

Any provision of this warranty which is invalid, prohibited or unenforceable in any jurisdiction shall, as to such jurisdiction, be ineffective to the extent of such invalidity, prohibition or unenforceability without invalidating the remaining provisions hereof, and any such invalidity, prohibition or unenforceability in any such jurisdiction shall not invalidate or render unenforceable such provision in any other jurisdiction.

Service

For Service or Technical Assistance: Contact your TLV representative or your regional TLV office.

In Europe:

TLV EURO ENGINEERING GmbH

Daimler-Benz-Straße 16-18, 74915 Waibstadt, **Germany**

Tel: [49]-(0)7263-9150-0
Fax: [49]-(0)7263-9150-50

TLV EURO ENGINEERING UK LTD.

Units 7 & 8, Furlong Business Park, Bishops Cleeve, Gloucestershire GL52 8TW, **U.K.**

Tel: [44]-(0)1242-227223
Fax: [44]-(0)1242-223077

TLV EURO ENGINEERING FRANCE SARL

Parc d'Ariane 2, bât. C, 290 rue Ferdinand Perrier, 69800 Saint Priest, **France**

Tel: 33-(0)4-72482222
Fax: [33]-(0)4-72482220

In North America:

TLV CORPORATION

13901 South Lakes Drive, Charlotte, NC 28273-6790, **U.S.A.**

Tel: [1]-704-597-9070
Fax: [1]-704-583-1610

In Mexico and Latin America:

TLV ENGINEERING S. A. DE C. V.

Av. Jesús del Monte 39-B-1001, Col. Hda. de las Palmas, Huixquilucan, Edo. de México, 52763, **Mexico**

Tel: [52]-55-5359-7949
Fax: [52]-55-5359-7585

In Oceania:

TLV PTY LIMITED

Unit 8, 137-145 Rooks Road, Nunawading, Victoria 3131, **Australia**

Tel: [61]-(0)3-9873 5610
Fax: [61]-(0)3-9873 5010

In East Asia:

TLV PTE LTD

36 Kaki Bukit Place, #02-01/02, **Singapore** 416214

Tel: [65]-6747 4600
Fax: [65]-6742 0345

TLV SHANGHAI CO., LTD.

Room 5406, No. 103 Cao Bao Road, Shanghai, **China** 200233

Tel: [86]-(0)21-6482-8622
Fax: [86]-(0)21-6482-8623

TLV ENGINEERING SDN. BHD.

No.16, Jalan MJ14, Taman Industri Meranti Jaya, 47120 Puchong, Selangor, **Malaysia**

Tel: [60]-3-8065-2928
Fax: [60]-3-8065-2923

TLV PRIVATE LIMITED

252/94 (K-L) 17th Floor, Muang Thai-Phatra Complex Tower B, Rachadaphisek Road, Huaykwang, Bangkok 10310, **Thailand**

Tel: [66]-2-693-3799
Fax: [66]-2-693-3979

TLV INC.

#302-1 Bundang Technopark B, 723 Pangyo-ro, Bundang, Seongnam, Gyeonggi, 13511, **Korea**

Tel: [82]-(0)31-726-2105
Fax: [82]-(0)31-726-2195

In the Middle East:

TLV ENGINEERING FZCO

Building 2W, No. M002, PO Box 371684, Dubai Airport Free Zone, Dubai, **UAE**

Email: sales-me@tlv.co.jp

In Other Countries:

TLV INTERNATIONAL, INC.

881 Nagasuna, Noguchi, Kakogawa, Hyogo 675-8511, **Japan**

Tel: [81]-(0)79-427-1818
Fax: [81]-(0)79-425-1167

Manufacturer:

TLV CO., LTD.

881 Nagasuna, Noguchi, Kakogawa, Hyogo 675-8511, **Japan**

Tel: [81]-(0)79-422-1122
Fax: [81]-(0)79-422-0112