



# Instruction Manual

## Automatic Air Vent **VS1C**

## Contents

Introduction .....	1
Safety Considerations .....	2
Features .....	4
Operation .....	4
Specifications .....	5
Configuration .....	6
Installation .....	7
Maintenance.....	8
Disassembly/Reassembly .....	9
Troubleshooting .....	11
TLV EXPRESS LIMITED WARRANTY .....	12
Service .....	14

## Introduction

Thank you for purchasing the TLV automatic air vent.

This product has been thoroughly inspected before being shipped from the factory. When the product is delivered, before doing anything else, check the specifications and external appearance to make sure nothing is out of the ordinary. Also be sure to read this manual carefully before use and follow the instructions to be sure of using the product properly.

The VS1C automatic air vent is designed to automatically discharge/release air trapped in water-carrying pipes during water transport. It also automatically discharges the air that was entrained in the water during operation and has subsequently been separated and collected in specific locations in the piping.









If detailed instructions for special order specifications or options not contained in this manual are required, please contact TLV for full details.

This instruction manual is intended for use with the model(s) listed on the front cover. It is necessary not only for installation but for subsequent maintenance, disassembly/reassembly and troubleshooting. Please keep it in a safe place for future reference.

## Safety Considerations

- Read this section carefully before use and be sure to follow the instructions.
- Installation, inspection, maintenance, repairs, disassembly, adjustment and valve opening/closing should be carried out only by trained maintenance personnel.
- The precautions listed in this manual are designed to ensure safety and prevent equipment damage and personal injury. For situations that may occur as a result of erroneous handling, three different types of cautionary items are used to indicate the degree of urgency and the scale of potential damage and danger: DANGER, WARNING and CAUTION.
- The three types of cautionary items above are very important for safety: be sure to observe all of them as they relate to installation, use, maintenance, and repair. Furthermore, TLV accepts no responsibility for any accidents or damage occurring as a result of failure to observe these precautions.

### Symbols

	<b>Indicates a DANGER, WARNING or CAUTION item.</b>
	Indicates an urgent situation which poses a threat of death or serious injury
	Indicates that there is a potential threat of death or serious injury
	Indicates that there is a possibility of injury or equipment/product damage
	<p><b>DO NOT use for toxic, flammable or otherwise hazardous fluids.</b></p> <p>This product is an air vent that discharges air from water piping system. Use only for water and/or air. This product is for intended use only. Improper use may result in such hazards as damage to the product or malfunctions that may lead to serious accidents.</p>
	<p><b>NEVER apply direct heat to the float.</b></p> <p>The float may explode due to increased internal pressure, causing accidents leading to serious injury or damage to property and equipment.</p>
	<p><b>Install properly and DO NOT use this product outside the recommended operating pressure, temperature and other specification ranges.</b></p> <p>Improper use may result in such hazards as damage to the product or malfunctions that may lead to serious accidents. Local regulations may restrict the use of this product to below the conditions quoted.</p>
	<p><b>DO NOT use this product in excess of the maximum operating pressure differential.</b></p> <p>Such use could make discharge impossible (blocked).</p>

Continued on the next page

	<p><b>Take measures to prevent people from coming into direct contact with product outlets.</b> Failure to do so may result in burns or other injury from the discharge of fluids.</p>
	<p><b>When disassembling or removing the product, wait until the internal pressure equals atmospheric pressure and the surface of the product has cooled to room temperature.</b> Disassembling or removing the product when it is hot or under pressure may lead to discharge of fluids, causing burns, other injuries or damage.</p>
	<p><b>Be sure to use only the recommended components when repairing the product, and NEVER attempt to modify the product in any way.</b> Failure to observe these precautions may result in damage to the product and burns or other injury due to malfunction or the discharge of fluids.</p>
	<p><b>Use only under conditions in which no freeze-up will occur.</b> Freezing may damage the product, leading to fluid discharge, which may cause burns or other injury.</p>
	<p><b>Use only under conditions in which no water hammer will occur.</b> The impact of water hammer may damage the product, leading to fluid discharge, which may cause burns or other injury.</p>

## Features

1. Precision-ground float and 3-point seating provide the tightest seal.
2. All stainless steel construction provides outstanding corrosion resistance.
3. The air vent has no hinges or levers: the only moving part is the precision-ground float, which eliminates concentrated wear and provides long service life.
4. Simple construction with few parts allows for easy maintenance.
5. The air vent is small and light.

## Operation



Take measures to prevent people from coming into direct contact with product outlets.

Failure to do so may result in burns or other injury from the discharge of fluids.

1. When water is transported, air inside the piping is forced into the air vent by the pressure of the flow. The float inside the air vent is in the lower position, thus the valve is fully open and allows the air that enters the air vent and fills the area around the float to then be discharged.

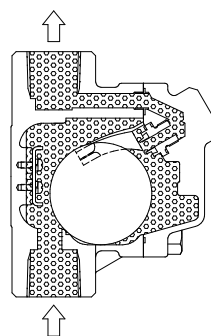

2. When discharge is completed, as water flows into the air vent, the rising water level causes the float to rise and to close the valve. If there is a rapid rise in water level (caused by rapidly opening a shut-off valve, etc.), a small amount of water may leak with discharged air immediately before the air vent closes.

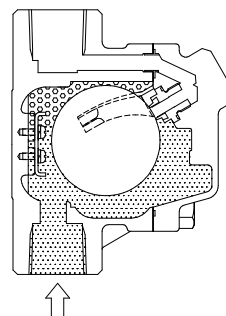

3. If air enters the air vent while the water is causing the valve to be closed, the air causes the water level to drop, thus the float loses buoyancy and the valve opens. After the air is discharged, the water level once again rises and the valve again becomes closed. In this manner, the air vent constantly responds to the amount of water flow by automatically adjusting discharge.

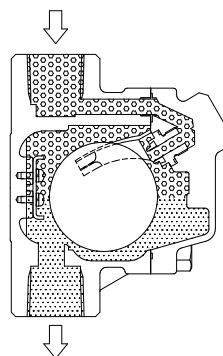

Air



Water

4. When draining the piping, the air vent automatically opens to introduce air and remove water more easily (preventing a vacuum from forming in the piping).

## Specifications

<b>⚠ WARNING</b>	<p><b>DO NOT use for toxic, flammable or otherwise hazardous fluids.</b></p> <p>This product is an air vent that discharges air from water piping system. Use only for water and/or air. This product is for intended use only. Improper use may result in such hazards as damage to the product or malfunctions that may lead to serious accidents.</p>
<b>⚠ CAUTION</b>	<p><b>Install properly and DO NOT use this product outside the recommended operating pressure, temperature and other specification ranges.</b></p> <p>Improper use may result in such hazards as damage to the product or malfunctions which may lead to serious accidents. Local regulations may restrict the use of this product to below the conditions quoted.</p> <p><b>DO NOT use this product in excess of the maximum operating pressure differential.</b></p> <p>Such use could make discharge impossible (blocked).</p> <p><b>Use only under conditions in which no freeze-up will occur.</b></p> <p>Freezing may damage the product, leading to fluid discharge, which may cause burns or other injury.</p>

Refer to the product nameplate for detailed specifications.

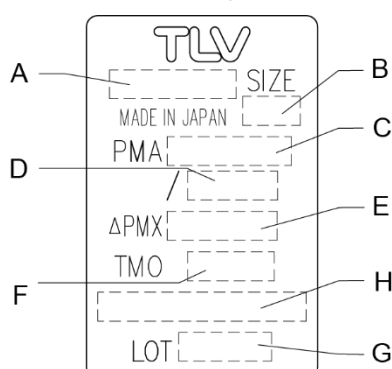

A	Model
B	Nominal Diameter
C	Maximum Allowable Pressure (PMA)
D	Maximum Allowable Temperature (TMA)
E	Maximum Differential Pressure (PMX)
F	Maximum Operating Temperature (TMO)
G	Production Lot No.
H	Valve No.**

\* Maximum allowable pressure (PMA) and maximum allowable temperature (TMA) are PRESSURE SHELL DESIGN CONDITIONS, **NOT** OPERATING CONDITIONS.

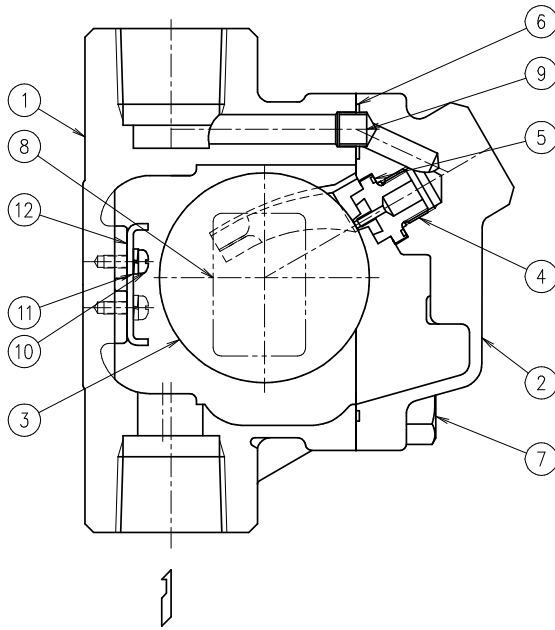

\*\* Valve No. is displayed for products with options. This item is omitted from the nameplate when there are no options.

## Configuration



No.	Name
1	Body
2	Cover
3	Float
4	Valve Seat
5	Valve Seat Gasket
6	Cover Gasket
7	Cover Bolt
8	Nameplate
9	Connector
10	Screw
11	Spring Washer
12	Guide Plate

## Installation

 <b>WARNING</b>	<p><b>DO NOT use for toxic, flammable or otherwise hazardous fluids.</b></p> <p>This product is an air vent that discharges air from water piping system. Use only for water and/or air. This product is for intended use only. Improper use may result in such hazards as damage to the product or malfunctions that may lead to serious accidents.</p>
 <b>CAUTION</b>	<p><b>Install properly and DO NOT use this product outside the recommended operating pressure, temperature and other specification ranges.</b></p> <p>Improper use may result in such hazards as damage to the product or malfunctions which may lead to serious accidents. Local regulations may restrict the use of this product to below the conditions quoted.</p> <p><b>Take measures to prevent people from coming into direct contact with product outlets.</b></p> <p>Failure to do so may result in burns or other injury from the discharge of fluids.</p>

Installation, inspection, maintenance, repairs, disassembly, adjustment and valve opening/closing should be carried out only by trained maintenance personnel.

1. Before installation, be sure to remove all protective seals.
2. Before installing the product, open the inlet valve and blow out the piping to remove any piping scraps, dirt and oil. Close the inlet valve after blowdown.
3. This product must be installed vertically, with the inlet at the bottom and the outlet at the top, and should be inclined no more than 5° horizontally and front-to-back (Figure 2).
4. Install the product in a location where air is likely to collect, such as a bend in the piping.
5. Install outlet piping leading to a drainage vessel or ditch. Make sure the end of the pipe is above the waterline, so that dirt and water can not be sucked up by vacuum when the system shuts down (Figure 1).
6. Inlet piping with no horizontal portion is recommended for water/air displacement. If there is a horizontal portion, make the pipe diameter of the horizontal portion larger than the vertical portion or make the horizontal portion as short as possible.
7. Make sure the inlet piping diameter is at least as large as the product's inlet diameter. For the inlet connection especially for the products with a nominal diameter of 15 mm ( $\frac{1}{2}$  in), use a pipe/fitting, etc. with an inner diameter of at least 16 mm ( $\frac{5}{8}$  in), such as a schedule 40 pipe nipple with a nominal diameter of 15 mm ( $\frac{1}{2}$  in). A smaller pipe may prevent water/air displacement.
8. Installation of an isolation valve just before the product's main connection is recommended as it enables maintenance during operation. A full-bore ball valve is recommended.
9. Make sure to take measures to prevent foreign matter from flowing into the product.

If there is a problem, determine the cause using the "Troubleshooting" section in this manual.

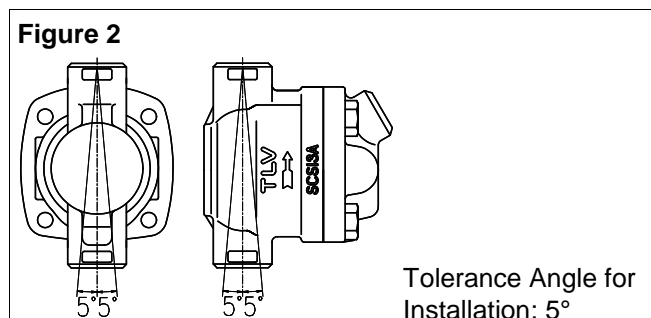
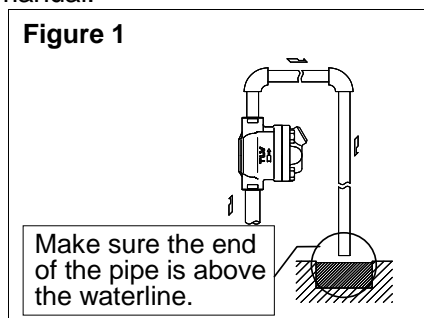



## Maintenance

	<p>Take measures to prevent people from coming into direct contact with product outlets. Failure to do so may result in burns or other injury from the discharge of fluids.</p>
	<p><b>Be sure to use only the recommended components when repairing the product, and NEVER attempt to modify the product in any way.</b> Failure to observe these precautions may result in damage to the product or burns or other injury due to malfunction or the discharge of fluids.</p>

### Operational Check

A visual inspection of the following items should be done on a daily basis to determine whether the product is operating properly or has failed.

If the product should fail, it may cause water leakage or hindrance to water flow.



Normal:	Air is discharged as it accumulates, with the air vent closing (with no leakage) when no air is present in the piping.
Blocked: (Discharge Impossible)	No air is discharged though air accumulates in the product.
Leakage:	Water from the piping is discharged or leaks through the product.

### Parts Inspection

When parts have been removed, or during periodic inspections, use the following table to inspect the parts and replace any that are found to be defective.

Procedure
Gaskets: Check for warping or scratches
Valve Seat Surface: Check for scratches or wear
Float: Check for scratches or dents, or water inside
Guide Plate: Check for damage

## Disassembly/Reassembly

 <b>WARNING</b>	<b>NEVER apply direct heat to the float.</b> The float may explode due to increased internal pressure, causing accidents leading to serious injury or damage to property and equipment.
 <b>CAUTION</b>	<b>When disassembling or removing the product, wait until the internal pressure equals atmospheric pressure and the surface of the product has cooled to room temperature.</b> Disassembling or removing the product when it is hot or under pressure may lead to discharge of fluids, causing burns, other injuries or damage. <b>Be sure to use only the recommended components when repairing the product, and NEVER attempt to modify the product in any way.</b> Failure to observe these precautions may result in damage to the product or burns or other injury due to malfunction or the discharge of fluids.

Use the following procedures to remove components. Use the same procedures in reverse to reassemble.

(Installation, inspection, maintenance, repairs, disassembly, adjustment and valve opening/closing should be carried out only by trained maintenance personnel.)

### Detaching/Reattaching the Cover and its Components

Part	During Disassembly	During Reassembly
Cover Bolt 7	Remove with a socket wrench	Consult the table of tightening torques and tighten to the proper torque
Cover 2	Remove carefully; take care to prevent any damage to the float, which may fall out when the cover is removed	Make sure the sealing surfaces are clean, then reattach; be careful not to bend the float guides
Float 3	Remove, being careful not to scratch the polished surface	Insert, being careful not to scratch the polished surface
Connector 9	Remove the connector	Reinsert into the hole in the cover
Cover Gasket 6	Remove if damaged	Replace with a new gasket if warped or damaged
Valve Seat 4	Remove with a socket wrench	Replace with a new valve seat if misshapen or damaged Consult the table of tightening torques and tighten to the proper torque
Valve Seat Gasket 5	Remove the gasket and clean sealing surfaces	Replace with a new gasket if warped or damaged

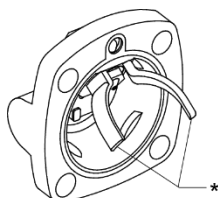

\* Float Guides

**NOTE:** The float guides are correctly positioned when shipped from the factory, so be careful when handling them. Tight sealing cannot be guaranteed if the float guides have been moved out of position.

### Body Interior Plate (part No. 12)

The guide plate built into the body with screws (and spring washer) does not require removal during normal product disassembly. The plate should only be replaced when it has become deformed or damaged. Upon reassembly, tighten to the proper torque.

### Table of Tightening Torques

Part Name	Torque		Distance Across Flats	
	N·m	(lbf·ft)	mm	(in)
Cover Bolt 7	45	(33)	17	( <sup>21</sup> / <sub>32</sub> )
Valve Seat 4	15	(11)	13	( <sup>1</sup> / <sub>2</sub> )
Screw (for Guide Plate 12)	0.3	(0.22)	+	

NOTE: - Coat all threaded portions with anti-seize. (1 N·m  $\approx$  10 kg·cm)

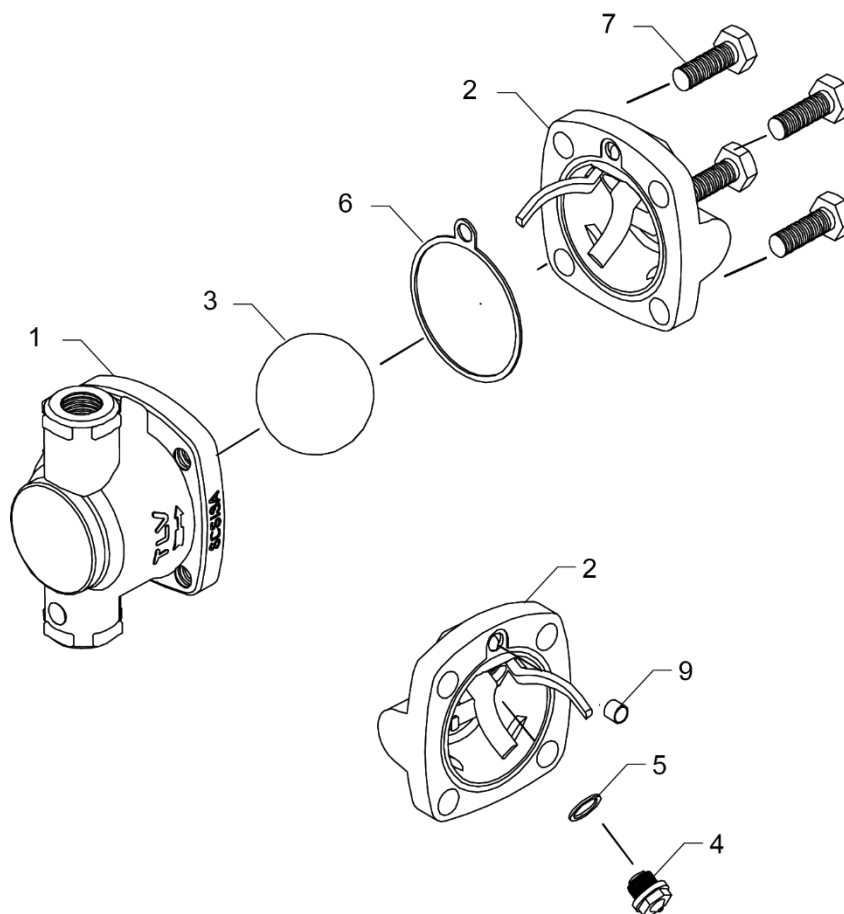

- If drawings or other special documentation were supplied for the product, any torque given there takes precedence over values shown here.

### Exploded View



No.	Name
1	Body
2	Cover
3	Float
4	Valve Seat
5	Valve Seat Gasket
6	Cover Gasket
7	Cover Bolt
8	Nameplate (not shown)
9	Connector

## Troubleshooting

 <b>WARNING</b>	<b>NEVER apply direct heat to the float.</b> The float may explode due to increased internal pressure, causing accidents leading to serious injury or damage to property and equipment.
 <b>CAUTION</b>	<b>When disassembling or removing the product, wait until the internal pressure equals atmospheric pressure and the surface of the product has cooled to room temperature.</b> Disassembling or removing the product when it is hot or under pressure may lead to discharge of fluids, causing burns, other injuries or damage.

When the product fails to operate properly, use the following table to locate the cause and remedy.

<b>Problem</b>	<b>Cause</b>	<b>Remedy</b>
No air discharged (blocked) or discharge is poor	Air is not reaching the vent because the water in the piping is not being displaced by air	Correct the inlet piping (Inner diameter should be at least 16mm ( <sup>5</sup> / <sub>8</sub> in))
	The valve seat is clogged	Clean the valve seat
	The inlet or outlet piping is clogged	Clean the piping and any upstream strainer
	Operating pressure exceeds the rated maximum operating pressure	Replace with a product of suitable operating pressure
Water leaks when valve is closed	The valve seat is clogged with dirt or scale or is damaged	Clean or replace with a new valve seat
	The float is dirty or coated with a film, or is deformed	Clean or replace with a new float
	Improper installation orientation	Correct the installation
Valve does not close, and water spurts out	Water is inside the float	Replace with a new float
	The guide plate is damaged	Replace with a new plate
	Specific gravity of the liquid is not suitable for this product	Select a product with suitable specifications for the operating conditions

## TLV EXPRESS LIMITED WARRANTY

Subject to the limitations set forth below, TLV CO., LTD., a Japanese corporation (“**TLV**”), warrants that products which are sold by it, TLV International Inc. (“**TII**”) or one of its group companies excluding TLV Corporation (a corporation of the United States of America), (hereinafter the “**Products**”) are designed and manufactured by TLV, conform to the specifications published by TLV for the corresponding part numbers (the “**Specifications**”) and are free from defective workmanship and materials. The party from whom the Products were purchased shall be known hereinafter as the “**Seller**”. With regard to products or components manufactured by unrelated third parties (the “**Components**”), TLV provides no warranty other than the warranty from the third party manufacturer(s), if any.

### Exceptions to Warranty

This warranty does not cover defects or failures caused by:

1. improper shipping, installation, use, handling, etc., by persons other than TLV, TII or TLV group company personnel, or service representatives authorized by TLV; or
2. dirt, scale or rust, etc.; or
3. improper disassembly and reassembly, or inadequate inspection and maintenance by persons other than TLV or TLV group company personnel, or service representatives authorized by TLV; or
4. disasters or forces of nature or Acts of God; or
5. abuse, abnormal use, accidents or any other cause beyond the control of TLV, TII or TLV group companies; or
6. improper storage, maintenance or repair; or
7. operation of the Products not in accordance with instructions issued with the Products or with accepted industry practices; or
8. use for a purpose or in a manner for which the Products were not intended; or
9. use of the Products in a manner inconsistent with the Specifications; or
10. use of the Products with Hazardous Fluids (fluids other than steam, air, water, nitrogen, carbon dioxide and inert gases (helium, neon, argon, krypton, xenon and radon)); or
11. failure to follow the instructions contained in the TLV Instruction Manual for the Product.

### Duration of Warranty

This warranty is effective for a period of one (1) year after delivery of Products to the first end user. Notwithstanding the foregoing, asserting a claim under this warranty must be brought within three (3) years after the date of delivery to the initial buyer if not sold initially to the first end user.

ANY IMPLIED WARRANTIES NOT NEGATED HEREBY WHICH MAY ARISE BY OPERATION OF LAW, INCLUDING THE IMPLIED WARRANTIES OF MERCHANTABILITY AND FITNESS FOR A PARTICULAR PURPOSE AND ANY EXPRESS WARRANTIES NOT NEGATED HEREBY, ARE GIVEN SOLELY TO THE INITIAL BUYER AND ARE LIMITED IN DURATION TO ONE (1) YEAR FROM THE DATE OF SHIPMENT BY THE SELLER.

### Exclusive Remedy

THE EXCLUSIVE REMEDY UNDER THIS WARRANTY, UNDER ANY EXPRESS WARRANTY OR UNDER ANY IMPLIED WARRANTIES NOT NEGATED HEREBY (INCLUDING THE IMPLIED WARRANTIES OF MERCHANTABILITY AND FITNESS FOR A PARTICULAR PURPOSE), IS **REPLACEMENT**; PROVIDED: (a) THE CLAIMED DEFECT IS

REPORTED TO THE SELLER IN WRITING WITHIN THE WARRANTY PERIOD, INCLUDING A DETAILED WRITTEN DESCRIPTION OF THE CLAIMED DEFECT AND HOW AND WHEN THE CLAIMED DEFECTIVE PRODUCT WAS USED; AND (b) THE CLAIMED DEFECTIVE PRODUCT AND A COPY OF THE PURCHASE INVOICE IS RETURNED TO THE SELLER, FREIGHT AND TRANSPORTATION COSTS PREPAID, UNDER A RETURN MATERIAL AUTHORIZATION AND TRACKING NUMBER ISSUED BY THE SELLER. ALL LABOR COSTS, SHIPPING COSTS, AND TRANSPORTATION COSTS ASSOCIATED WITH THE RETURN OR REPLACEMENT OF THE CLAIMED DEFECTIVE PRODUCT ARE SOLELY THE RESPONSIBILITY OF BUYER OR THE FIRST END USER. THE SELLER RESERVES THE RIGHT TO INSPECT ON THE FIRST END USER'S SITE ANY PRODUCTS CLAIMED TO BE DEFECTIVE BEFORE ISSUING A RETURN MATERIAL AUTHORIZATION. SHOULD SUCH INSPECTION REVEAL, IN THE SELLER'S REASONABLE DISCRETION, THAT THE CLAIMED DEFECT IS NOT COVERED BY THIS WARRANTY, THE PARTY ASSERTING THIS WARRANTY SHALL PAY THE SELLER FOR THE TIME AND EXPENSES RELATED TO SUCH ON-SITE INSPECTION.

#### **Exclusion of Consequential and Incidental Damages**

IT IS SPECIFICALLY ACKNOWLEDGED THAT THIS WARRANTY, ANY OTHER EXPRESS WARRANTY NOT NEGATED HEREBY, AND ANY IMPLIED WARRANTY NOT NEGATED HEREBY, INCLUDING THE IMPLIED WARRANTIES OF MERCHANTABILITY AND FITNESS FOR A PARTICULAR PURPOSE, DO NOT COVER, AND NEITHER TLV, TII NOR ITS TLV GROUP COMPANIES WILL IN ANY EVENT BE LIABLE FOR, INCIDENTAL OR CONSEQUENTIAL DAMAGES, INCLUDING, BUT NOT LIMITED TO LOST PROFITS, THE COST OF DISASSEMBLY AND SHIPMENT OF THE DEFECTIVE PRODUCT, INJURY TO OTHER PROPERTY, DAMAGE TO BUYER'S OR THE FIRST END USER'S PRODUCT, DAMAGE TO BUYER'S OR THE FIRST END USER'S PROCESSES, LOSS OF USE, OR OTHER COMMERCIAL LOSSES. WHERE, DUE TO OPERATION OF LAW, CONSEQUENTIAL AND INCIDENTAL DAMAGES UNDER THIS WARRANTY, UNDER ANY OTHER EXPRESS WARRANTY NOT NEGATED HEREBY OR UNDER ANY IMPLIED WARRANTY NOT NEGATED HEREBY (INCLUDING THE IMPLIED WARRANTIES OF MERCHANTABILITY AND FITNESS FOR A PARTICULAR PURPOSE) CANNOT BE EXCLUDED, SUCH DAMAGES ARE EXPRESSLY LIMITED IN AMOUNT TO THE PURCHASE PRICE OF THE DEFECTIVE PRODUCT. THIS EXCLUSION OF CONSEQUENTIAL AND INCIDENTAL DAMAGES, AND THE PROVISION OF THIS WARRANTY LIMITING REMEDIES HEREUNDER TO REPLACEMENT, ARE INDEPENDENT PROVISIONS, AND ANY DETERMINATION THAT THE LIMITATION OF REMEDIES FAILS OF ITS ESSENTIAL PURPOSE OR ANY OTHER DETERMINATION THAT EITHER OF THE ABOVE REMEDIES IS UNENFORCEABLE, SHALL NOT BE CONSTRUED TO MAKE THE OTHER PROVISIONS UNENFORCEABLE.

#### **Exclusion of Other Warranties**

THIS WARRANTY IS IN LIEU OF ALL OTHER WARRANTIES, EXPRESS OR IMPLIED, AND ALL OTHER WARRANTIES, INCLUDING BUT NOT LIMITED TO THE IMPLIED WARRANTIES OF MERCHANTABILITY AND FITNESS FOR A PARTICULAR PURPOSE, ARE EXPRESSLY DISCLAIMED.

#### **Severability**

Any provision of this warranty which is invalid, prohibited or unenforceable in any jurisdiction shall, as to such jurisdiction, be ineffective to the extent of such invalidity, prohibition or unenforceability without invalidating the remaining provisions hereof, and any such invalidity, prohibition or unenforceability in any such jurisdiction shall not invalidate or render unenforceable such provision in any other jurisdiction.

## Service

For Service or Technical Assistance: Contact your TLV representative or your regional TLV office.

### In Europe:

#### **TLV EURO ENGINEERING GmbH**

Daimler-Benz-Straße 16-18, 74915 Waibstadt, **Germany**

Tel: [49]-(0)7263-9150-0  
Fax: [49]-(0)7263-9150-50

#### **TLV EURO ENGINEERING UK LTD.**

Units 7 & 8, Furlong Business Park, Bishops Cleeve, Gloucestershire GL52 8TW, **U.K.**

Tel: [44]-(0)1242-227223  
Fax: [44]-(0)1242-223077

#### **TLV EURO ENGINEERING FRANCE SARL**

Parc d'Ariane 2, bât. C, 290 rue Ferdinand Perrier, 69800 Saint Priest, **France**

Tel: 33-(0)4-72482222  
Fax: [33]-(0)4-72482220

### In North America:

#### **TLV CORPORATION**

13901 South Lakes Drive, Charlotte, NC 28273-6790, **U.S.A.**

Tel: [1]-704-597-9070  
Fax: [1]-704-583-1610

### In Mexico and Latin America:

#### **TLV ENGINEERING S. A. DE C. V.**

Av. Jesús del Monte 39-B-1001, Col. Hda. de las Palmas, Huixquilucan, Edo. de México, 52763, **Mexico**

Tel: [52]-55-5359-7949  
Fax: [52]-55-5359-7585

### In Oceania:

#### **TLV PTY LIMITED**

Unit 8, 137-145 Rooks Road, Nunawading, Victoria 3131, **Australia**

Tel: [61]-(0)3-9873 5610  
Fax: [61]-(0)3-9873 5010

### In East Asia:

#### **TLV PTE LTD**

36 Kaki Bukit Place, #02-01/02, **Singapore** 416214

Tel: [65]-6747 4600  
Fax: [65]-6742 0345

#### **TLV SHANGHAI CO., LTD.**

Room 5406, No. 103 Cao Bao Road, Shanghai, **China** 200233

Tel: [86]-(0)21-6482-8622  
Fax: [86]-(0)21-6482-8623

#### **TLV ENGINEERING SDN. BHD.**

No.16, Jalan MJ14, Taman Industri Meranti Jaya, 47120 Puchong, Selangor, **Malaysia**

Tel: [60]-3-8065-2928  
Fax: [60]-3-8065-2923

#### **TLV PRIVATE LIMITED**

252/94 (K-L) 17th Floor, Muang Thai-Phatra Complex Tower B, Rachadaphisek Road, Huaykwang, Bangkok 10310, **Thailand**

Tel: [66]-2-693-3799  
Fax: [66]-2-693-3979

#### **TLV INC.**

#302-1 Bundang Technopark B, 723 Pangyo-ro, Bundang, Seongnam, Gyeonggi, 13511, **Korea**

Tel: [82]-(0)31-726-2105  
Fax: [82]-(0)31-726-2195

### In the Middle East:

#### **TLV ENGINEERING FZCO**

Building 2W, No. M002, PO Box 371684, Dubai Airport Free Zone, Dubai, **UAE**

Email: sales-me@tlv.co.jp

### In Other Countries:

#### **TLV INTERNATIONAL, INC.**

881 Nagasuna, Noguchi, Kakogawa, Hyogo 675-8511, **Japan**

Tel: [81]-(0)79-427-1818  
Fax: [81]-(0)79-425-1167

### Manufacturer:

#### **TLV CO., LTD.**

881 Nagasuna, Noguchi, Kakogawa, Hyogo 675-8511, **Japan**

Tel: [81]-(0)79-422-1122  
Fax: [81]-(0)79-422-0112