



Instruction Manual

Free Float Steam Trap

JH3S-B

JH5SL-B

JH5SH-B

Contents

Introduction	1
Safety Considerations	2
Checking the Piping	4
Operation	5
Specifications	6
Configuration	6
Installation	8
Maintenance	9
Disassembly/Reassembly	10
Instructions for Plug/Holder Disassembly and Reassembly ...	14
Troubleshooting	15
Product Warranty	16
Options	17

Introduction

Thank you for purchasing the TLV free float steam trap.

This product has been thoroughly inspected before being shipped from the factory. When the product is delivered, before doing anything else, check the specifications and external appearance to make sure nothing is out of the ordinary. Also be sure to read this manual carefully before use and follow the instructions to be sure of using the product properly.

This free float steam trap employs a hinge-less and lever-less free float to rapidly, automatically and continuously discharge the inflowing condensate that is continuously generated inside the equipment, thus preventing the accumulation of condensate and thereby improving the heat transfer efficiency of the equipment. In addition, the integral bimetal type automatic air vent allows for the rapid release of start-up air and thereby reduces start-up time.

These features make this free float steam trap suitable for applications requiring condensate discharge from process systems and equipment (steam-using equipment).

This steam trap also employs a precision-ground float and three-point seating that supports the float securely at three points and ensures a high degree of sealing when even only minute quantities of condensate are present. This free float steam trap is also ideal for places at which extremely small amounts of condensate are generated, such as superheated and saturated steam mains and branches, and trace lines.







If detailed instructions for special order specifications or options not contained in this manual are required, please contact TLV for full details.

This instruction manual is intended for use with the model(s) listed on the front cover. It is necessary not only for installation but for subsequent maintenance, disassembly/reassembly and troubleshooting. Please keep it in a safe place for future reference.

Safety Considerations

- Read this section carefully before use and be sure to follow the instructions.
- Installation, inspection, maintenance, repairs, disassembly, adjustment and valve opening/closing should be carried out only by trained maintenance personnel.
- The precautions listed in this manual are designed to ensure safety and prevent equipment damage and personal injury. For situations that may occur as a result of erroneous handling, three different types of cautionary items are used to indicate the degree of urgency and the scale of potential damage and danger: DANGER, WARNING and CAUTION.
- The three types of cautionary items above are very important for safety: be sure to observe all of them as they relate to installation, use, maintenance, and repair. Furthermore, TLV accepts no responsibility for any accidents or damage occurring as a result of failure to observe these precautions.

Symbols

	Indicates a DANGER, WARNING or CAUTION item.
	Indicates an urgent situation which poses a threat of death or serious injury
	Indicates that there is a potential threat of death or serious injury
	Indicates that there is a possibility of injury or equipment/product damage
	<p>NEVER apply direct heat to the float. The float may explode due to increased internal pressure, causing accidents leading to serious injury or damage to property and equipment.</p>
	<p>Install properly and DO NOT use this product outside the recommended operating pressure, temperature and other specification ranges. Improper use may result in such hazards as damage to the product or malfunctions that may lead to serious accidents. Local regulations may restrict the use of this product to below the conditions quoted.</p> <p>DO NOT use this product in excess of the maximum operating pressure differential. Such use could make discharge impossible (blocked).</p> <p>Take measures to prevent people from coming into direct contact with product outlets. Failure to do so may result in burns or other injury from the discharge of fluids.</p> <p>When disassembling or removing the product, wait until the internal pressure equals atmospheric pressure and the surface of the product has cooled to room temperature. Disassembling or removing the product when it is hot or under pressure may lead to discharge of fluids, causing burns, other injuries or damage.</p>

Safety considerations continued on next page.

 CAUTION	<p>Be sure to use only the recommended components when repairing the product, and NEVER attempt to modify the product in any way.</p> <p>Failure to observe these precautions may result in damage to the product and burns or other injury due to malfunction or the discharge of fluids.</p>
	<p>Use only under conditions in which no freeze-up will occur.</p> <p>Freezing may damage the product, leading to fluid discharge, which may cause burns or other injury.</p>
	<p>Use only under conditions in which no water hammer will occur.</p> <p>The impact of water hammer may damage the product, leading to fluid discharge, which may cause burns or other injury.</p>

Checking the Piping



Use only under conditions in which no water hammer will occur. The impact of water hammer may damage the product, leading to fluid discharge, which may cause burns or other injury.

Check to make sure that the pipes to be connected to the trap have been installed properly.

1. Is the pipe diameter suitable?
2. Is the piping where the trap is to be installed horizontal?
3. Has sufficient space been secured for maintenance?
4. Have maintenance valves been installed at the inlet and outlet? If the outlet is subject to back pressure, has a check valve (TLV-CK) been installed?
5. Is the inlet pipe as short as possible, with as few bends as possible, and installed so the liquid will flow naturally down into the trap?
6. Has the piping work been done correctly, as shown in the figures below?

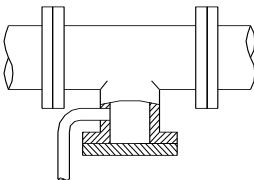
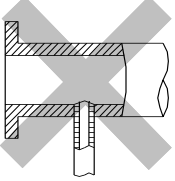
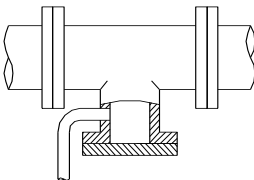
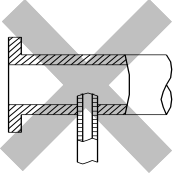
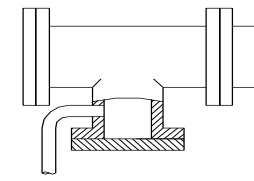
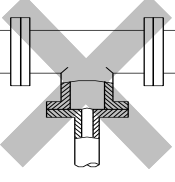
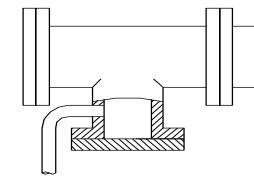
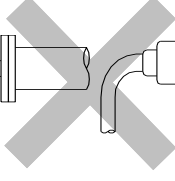
Requirement	Correct	Incorrect
Install catchpot with the proper diameter.		 Diameter is too small.
Make sure the flow of condensate is not obstructed.		 Diameter is too small and inlet protrudes into pipe interior.
To prevent rust and scale from flowing into the trap, the inlet pipe should be connected 25 – 50 mm (1 – 2 in) above the base of the T-pipe.		 Rust and scale flow into the trap with the condensate.
When installing on the blind end, make sure the flow of condensate is not obstructed.		 Condensate collects in the pipe.

Operation

Principles of air and condensate discharge:

1. Initial Air and Cold Condensate Discharge

At startup, before steam is supplied the system is cold and the bimetal plate is flexed downward, keeping the air vent valve (A) open. This allows for the rapid discharge of air and cold condensate through the vent (A) when steam is first supplied to the system.

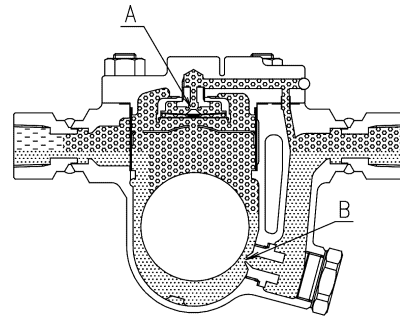

2. Condensate Discharge

After the discharge of initial air and cold condensate, the heat of the inflowing steam and condensate cause the bimetal plate to flex upward, closing the air vent valve (A). The rising condensate level causes the float to rise due to buoyancy, opening the orifice (B) and allowing condensate to be discharged. The flexed bimetal keeps the valve closed while in normal operation.

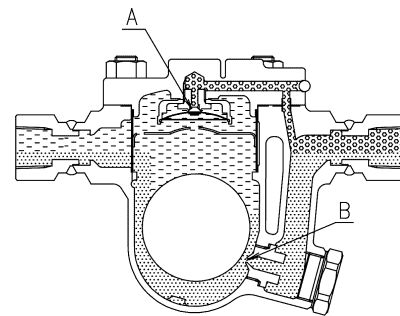

3. Discharge of Large Quantities of Condensate

Increases in the condensate inflow rate cause the condensate level in the trap to rise. The float consequently rises and enlarges the opening of the orifice (B), allowing more condensate to be discharged. In this manner, continuous condensate discharge occurs while the opening size of the orifice varies depending on the condensate flow rate.

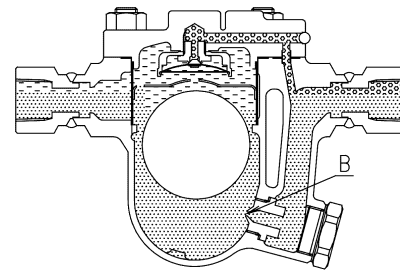

4. Closed Position

When the condensate flow rate decreases, the float falls, closing off the orifice (B) opening. A water seal is maintained at all times over the orifice (B) to prevent steam loss.

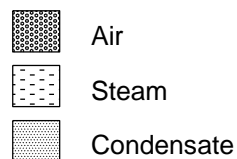
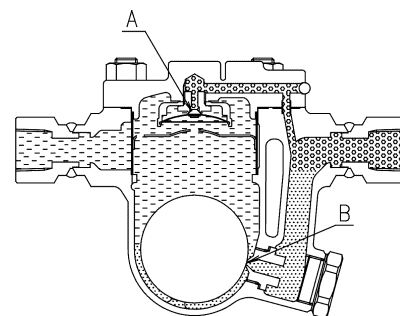

Specifications



Install properly and **DO NOT** use this product outside the recommended operating pressure, temperature and other specification ranges. Improper use may result in such hazards as damage to the product or malfunctions which may lead to serious accidents. Local regulations may restrict the use of this product to below the conditions quoted.

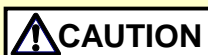

DO NOT use the product in excess of the maximum operating pressure differential; such use could make discharge impossible (blocked).



Use only under conditions in which no freeze-up will occur. Freezing may damage the product, leading to fluid discharge, which may cause burns or other injury.

Refer to the product nameplate for detailed specifications.

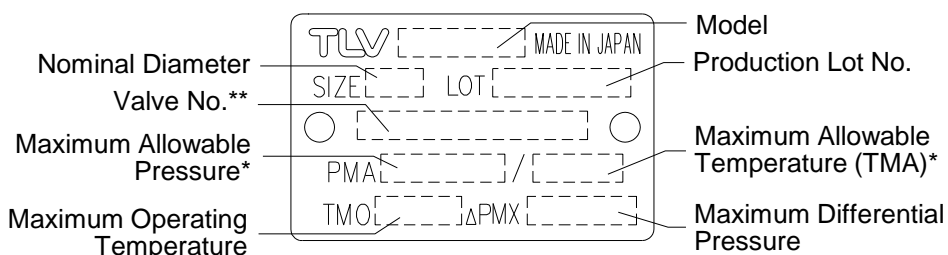

* Maximum allowable pressure (PMA) and maximum allowable temperature (TMA) are PRESSURE SHELL DESIGN CONDITIONS, **NOT** OPERATING CONDITIONS.

** Valve No. is displayed for products with options. This item is omitted from the nameplate when there are no options.

Configuration

JH3S-B

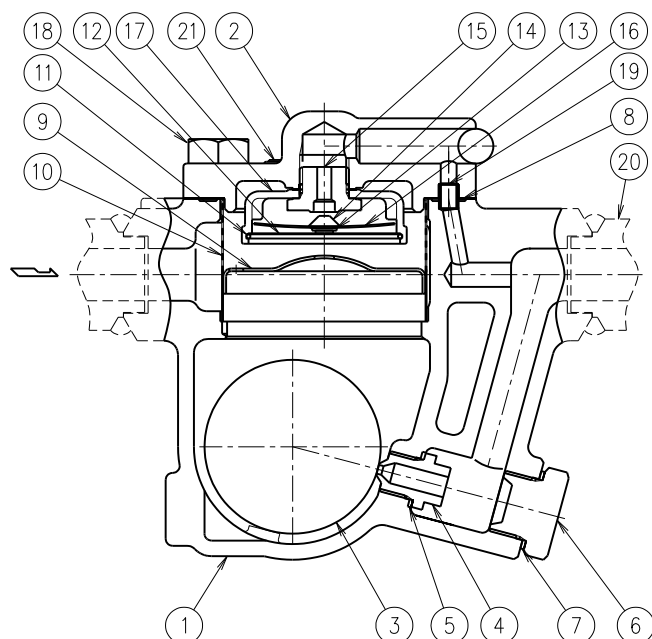

No.	Name	M*	R*	F*
1	Body			
2	Cover			
3	Float			✓
4	Orifice		✓	
5	Orifice Gasket	✓	✓	
6	Orifice Plug			
7	Orifice Plug Gasket	✓	✓	
8	Cover Gasket	✓	✓	
9	Float Cover		✓	
10	Screen		✓	
11	Snap Ring		✓	
12	Air Vent Screen		✓	
13	Snap Ring		✓	
14	Air Vent Valve Plug		✓	
15	Air Vent Valve Seat		✓	
16	Bimetal Plate		✓	
17	Air Vent Case		✓	
18	Cover Bolt			
19	Connector			
20	Flange/Socket			
21	Nameplate			

* Replacement parts are available only in the following kits: M = maintenance kit, R = repair kit, F = float

JH5SL-B/JH5SH-B

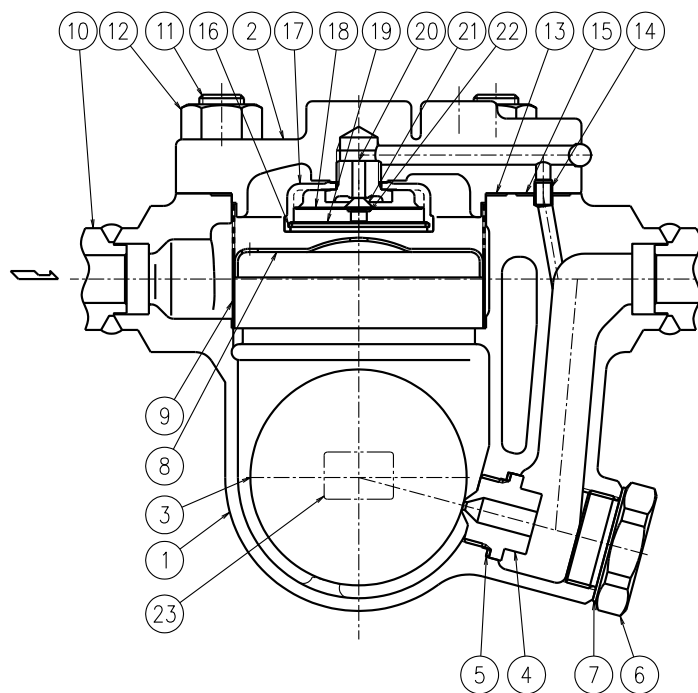

No.	Name	M*	R*	F*
1	Body			
2	Cover			
3	Float			✓
4	Orifice		✓	
5	Orifice Gasket	✓	✓	
6	Orifice Plug			
7	Orifice Plug Gasket	✓	✓	
8	Float Cover		✓	
9	Screen		✓	
10	Flange/Socket			
11	Cover Bolt			
12	Cover Nut			
13	Cover Gasket	✓	✓	
14	Connector			
15	Connector Gasket	✓	✓	
16	Snap Ring		✓	
17	Air Vent Case		✓	
18	Bimetal Plate		✓	
19	Air Vent Screen		✓	
20	Air Vent Valve Seat		✓	
21	Air Vent Valve Plug		✓	
22	Snap Ring		✓	
23	Nameplate			

* Replacement parts are available only in the following kits: M = maintenance kit, R = repair kit, F = float

Installation



Install properly and **DO NOT** use this product outside the recommended operating pressure, temperature and other specification ranges. Improper use may result in such hazards as damage to the product or malfunctions which may lead to serious accidents. Local regulations may restrict the use of this product to below the conditions quoted.



Take measures to prevent people from coming into direct contact with product outlets. Failure to do so may result in burns or other injury from the discharge of fluids.

Installation, inspection, maintenance, repairs, disassembly, adjustment and valve opening/closing should be carried out only by trained maintenance personnel.

1. Before installation, be sure to remove all protective seals.
2. Before installing the product, open the inlet valve and blow out the piping to remove any piping scraps, dirt and oil. Close the inlet valve after blowdown.
3. Install the product so the arrow on the body is pointing in the direction of flow.
4. The product should be inclined no more than 5° horizontally and front-to-back.
5. Install a condensate outlet valve and outlet piping.
6. Open the inlet and outlet valves and ensure that the product functions properly.

If there is a problem, determine the cause using the “Troubleshooting” section in this manual.

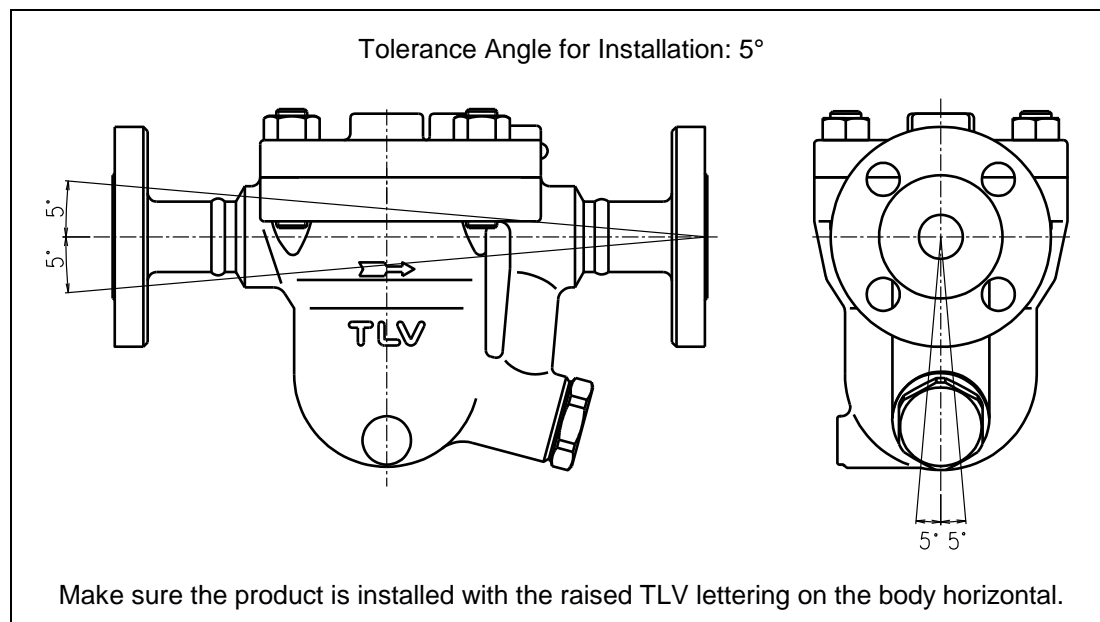

Maintenance



Be sure to use only the recommended components when repairing the product, and NEVER attempt to modify the product in any way. Failure to observe these precautions may result in damage to the product or burns or other injury due to malfunction or the discharge of fluids.



Take measures to prevent people from coming into direct contact with product outlets. Failure to do so may result in burns or other injury from the discharge of fluids.

Operational Check

A visual inspection of the following items should be done on a daily basis to determine whether the product is operating properly or has failed. Periodically (at least biannually) the operation should also be checked by using diagnostic equipment, such as a stethoscope, thermometer, TLV Pocket TrapMan or TrapMan.

If the product should fail, it may cause damage to piping and equipment, resulting in faulty or low-quality products or losses due to steam leakage.

Normal:	Condensate is discharged continuously, together with flash steam, and the sound of flow can be heard. If there is very little condensate, there is almost no sound of flow.
Blocked: (Discharge Impossible)	No condensate is discharged. The trap is quiet and makes no noise, and the surface temperature of the trap is low.
Blowing:	Live steam continually flows from the outlet and there is a continuous metallic sound.
Steam Leakage:	Live steam is discharged through the trap outlet together with condensate, accompanied by a high-pitched sound.

(When conducting a visual inspection, flash steam is sometimes mistaken for steam leakage. For this reason, the use of a steam trap diagnostic instrument – such as TLV TrapMan – in conjunction with the visual inspection is highly recommended.)

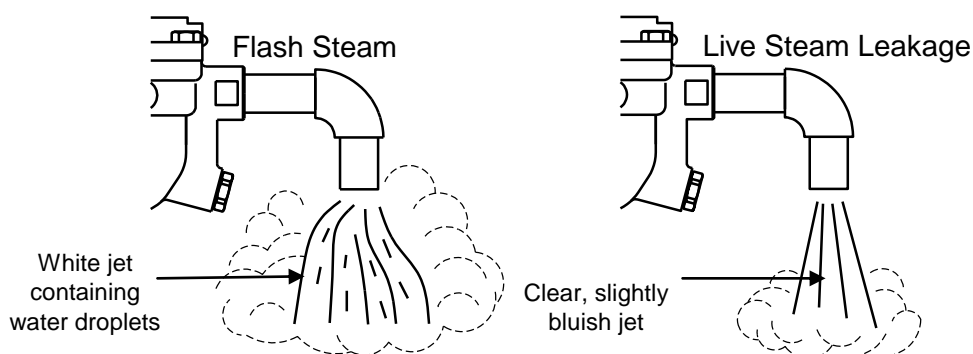

Parts Inspection

When parts have been removed, or during periodic inspections, use the following table to inspect the parts and replace any that are found to be defective.

Procedure	
Gaskets:	Check for warping or scratches
Screens:	Check for clogging or corrosion
Bimetal Plate:	Check for scratches
Air Vent Valve (and Seat):	Check for scratches
Float:	Check for scratches or dents
Body Interior:	Check for build-up
Orifice Opening:	Check for dirt, oil film wear or scratches

Disassembly/Reassembly



NEVER apply direct heat to the float. The float may explode due to increased internal pressure, causing accidents leading to serious injury or damage to property and equipment.

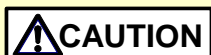

When disassembling or removing the product, wait until the internal pressure equals atmospheric pressure and the surface of the product has cooled to room temperature. Disassembling or removing the product when it is hot or under pressure may lead to discharge of fluids, causing burns, other injuries or damage.

Use the following procedures to remove components. Use the same procedures in reverse to reassemble. (Installation, inspection, maintenance, repairs, disassembly, adjustment and valve opening/closing should be carried out only by trained maintenance personnel.)

Drain Plug (Option)

Part	During Disassembly	During Reassembly
Drain Plug	Remove with a socket wrench	Consult the table of tightening torques and tighten to the proper torque
Drain Plug Gasket	Remove the gasket and clean sealing surfaces	Replace with a new gasket; coat surfaces with anti-seize

Detaching/Reattaching the Cover

Part	During Disassembly	During Reassembly
Cover Nut / Cover Bolt	Remove with a socket wrench	Consult the table of tightening torques and tighten to the proper torque
Cover	Remove by lifting up and off	Make sure there are no pieces of the old gasket left on the sealing surfaces of the body and cover, then reattach, lining up the connector
Cover Gasket	Remove the gasket and clean sealing surfaces	Replace with a new gasket
Connector	Remove the connector	Reinsert into hole in body
Connector Gasket (Only JH5SL-B/ JH5SH-B)	Remove the gasket and clean sealing surfaces	Replace with a new gasket

Disassembly/Reassembly of Components Inside the Cover

Part	During Disassembly	During Reassembly
Snap Ring	Pinch the insides together and remove from the cover	Insert securely into the groove
Screen	Remove, being careful not to misshape	Replace, being careful not to misshape
Bimetal Plate/ Air Vent Valve Plug/ Snap Ring	Remove the air vent parts from cover	Make sure to reinsert in the proper orientation (Fig. A)
Air Vent Valve Seat	Remove with a socket wrench	Consult the table of tightening torques and tighten to the proper torque
Air Vent Case	Remove from the cover	Place in cover

Figure A

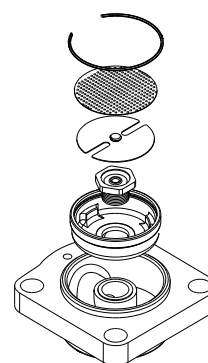

Disassembly / Reassembly of Components Inside the Body

Part	During Disassembly	During Reassembly
Float Cover/ Screen	Lift straight up and out while gently rocking	Align the arrows on the float cover/screen and body and insert the tab on the bottom of the float cover/screen into the slot in the body; make sure the top of the float cover/screen does not stick up out of the body (Fig. B)
Float	Remove, being careful not to scratch the polished surface	Insert, being careful not to scratch the polished surface
Orifice Plug	Remove with a socket wrench	Consult the table of tightening torques and tighten to the proper torque
Orifice Plug Gasket	Remove the gasket and clean sealing surfaces	Replace with a new gasket; coat surfaces with anti-seize
Orifice	Remove with a socket wrench	Consult the table of tightening torques and tighten to the proper torque
Orifice Gasket	Remove the gasket and clean sealing surfaces	Replace with a new gasket; coat surfaces with anti-seize

Figure B

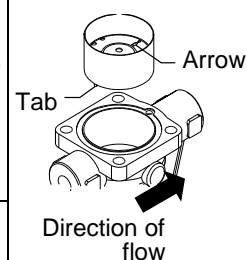

Table of Tightening Torques

Part Name	Torque				Distance Across Flats			
	N·m (lbf·ft)		N·m (lbf·ft)		mm (in)		mm (in)	
Model	JH3S-B		JH5SL-B/ JH5SH-B		JH3S-B		JH5SL-B/ JH5SH-B	
Orifice	30	(22)	140	(100)	10	(³ / ₈)	17	(²¹ / ₃₂)
Orifice Plug	80	(59)	180	(130)	24	(¹⁵ / ₁₆)	38	(1 ¹ / ₂)
Air Vent Valve Seat	30	(22)	30	(22)	17	(²¹ / ₃₂)	19	(³ / ₄)
Cover Bolt (JH5SL-B)	50	(37)	—		17	(²¹ / ₃₂)	—	
Cover Nut (JH5SL-B)	—		110	(81)	—		22	(¹ / ₈)
Cover Nut (JH5SH-B)	—		170	(125)	—		24	(¹⁵ / ₁₆)

NOTE: -Coat all threaded portions with anti-seize.

(1 N·m ≈ 10 kg·cm)

-If drawings or other special documentation were supplied for the product, any torque given there takes precedence over values shown here.

Exploded View

JH3S-B

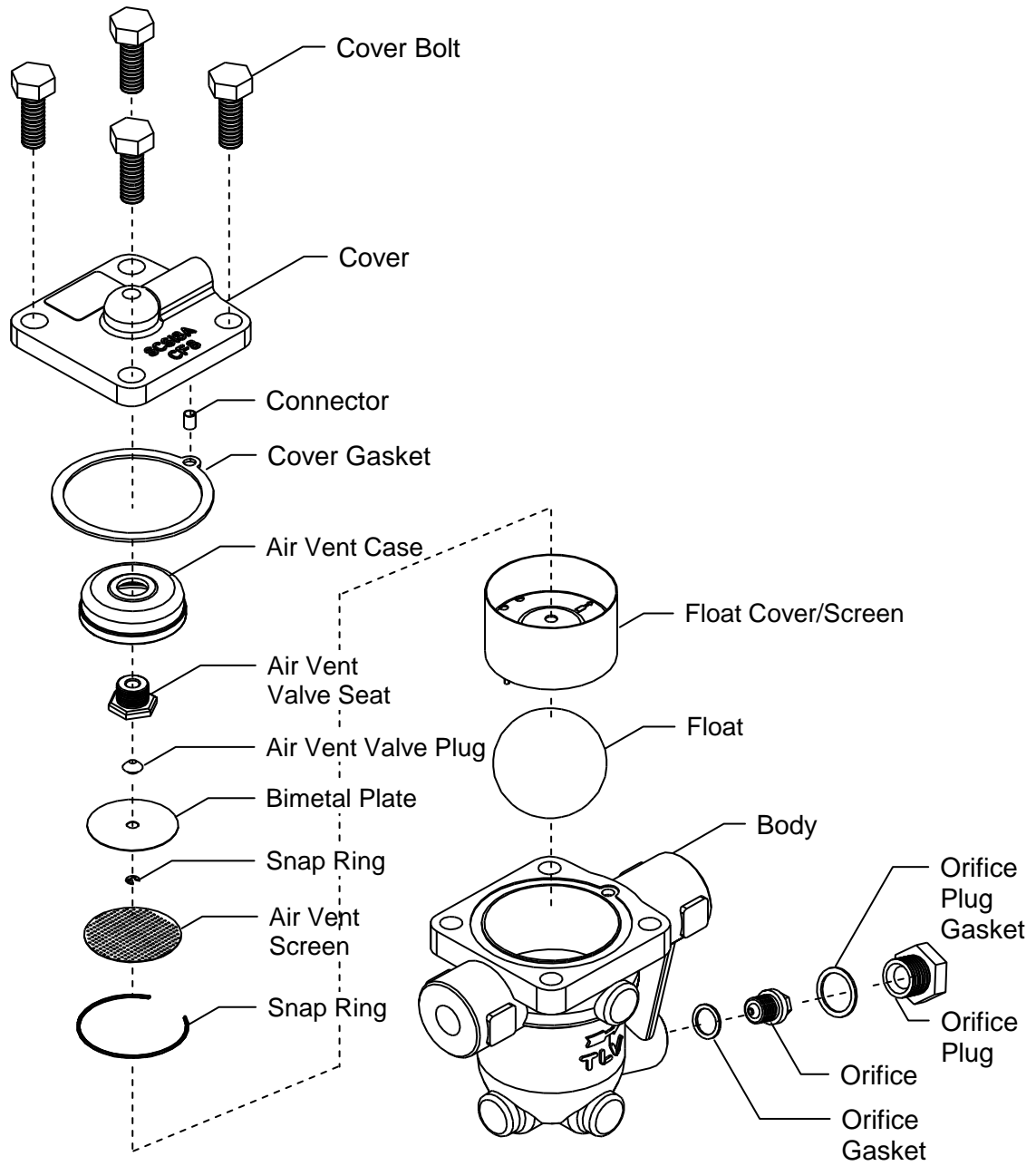

JH5SL-B / JH5SH-B

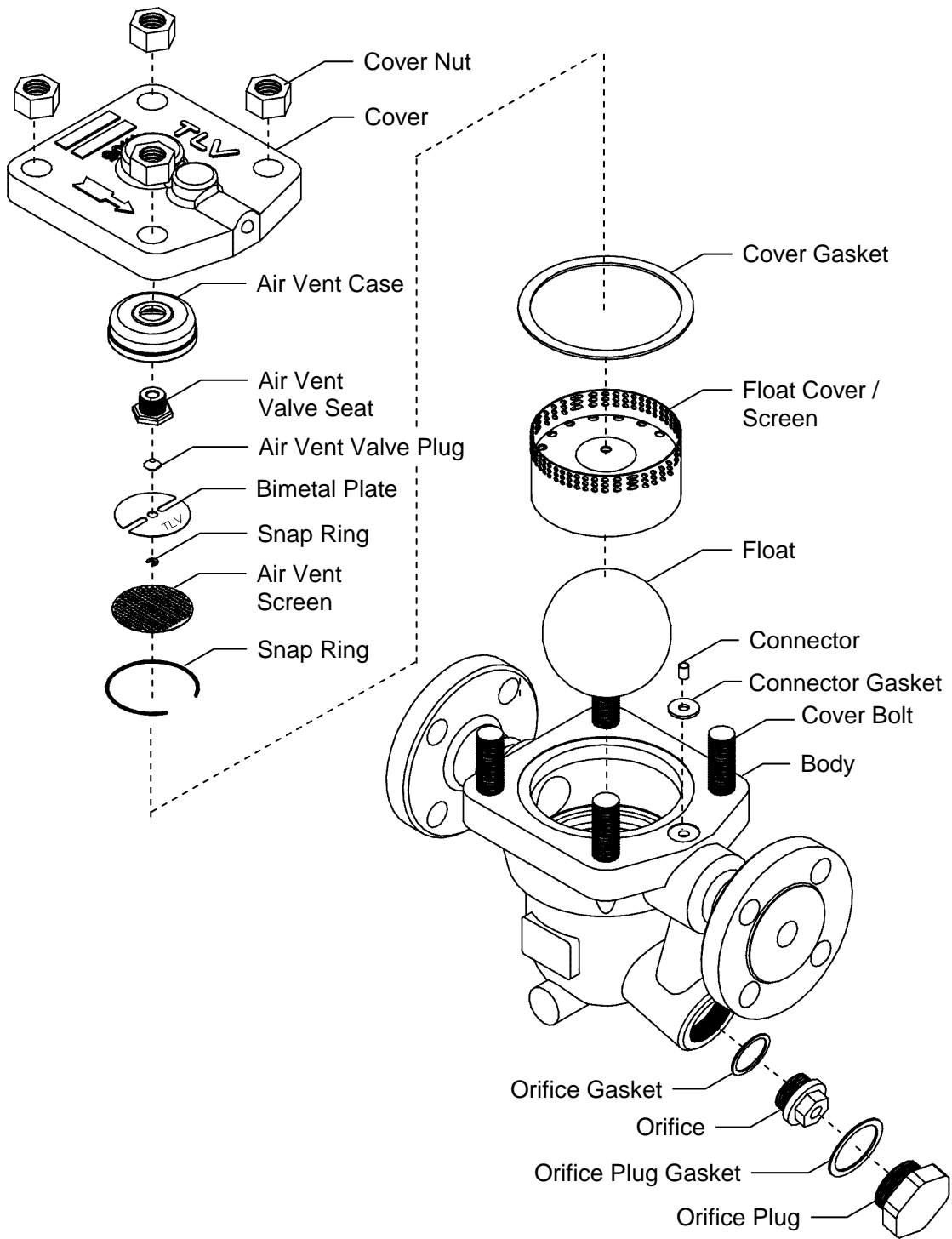

Instructions for Plug/Holder Disassembly and Reassembly

The seal on the threaded plugs/holders found on TLV products is formed by a flat metal gasket. There are various installation orientations for the gaskets, such as horizontal, diagonal and downward, and the gasket may be pinched in the thread recesses during assembly.

Instructions for Disassembly and Reassembly

1. Remove the plug/holder using a tool of the specified size (distance across flats).
2. The gasket should not be reused. Be sure to replace it with a new gasket.
3. Clean the gasket surfaces of the plug/holder and the product body using a rag and/or cleaning agents, then check to make sure the surfaces are not scratched or deformed.
4. Coat both the gasket surface of the plug/holder and the threads of the plug/holder with anti-seize, then press the gasket onto the center of the gasket surface of the plug/holder, making sure the anti-seize affixes the gasket tightly to the plug/holder. Check to make sure the gasket is not caught in the recesses of the threads.
5. Hold the plug/holder upside down to make sure that the anti-seize makes the gasket stick to the plug/holder even when the plug/holder is held upside down.
6. Screw the plug/holder by hand into the product body while making sure that the gasket remains tightly affixed to the center of the gasket surface of the plug/holder. Make sure the entire gasket is making contact with the gasket surface of the product body. It is important at this point to make sure the gasket is not pinched in the thread recesses of the plug/holder.
7. Tighten the plug/holder to the proper torque.
8. Next, begin the supply of steam and check to make sure there is no leakage from the part just tightened. If there is leakage, immediately close the inlet valve and, if there is a bypass valve, take the necessary steps to release any residual pressure. After the surface of the product cools to room temperature, repeat the procedure beginning from step 1.

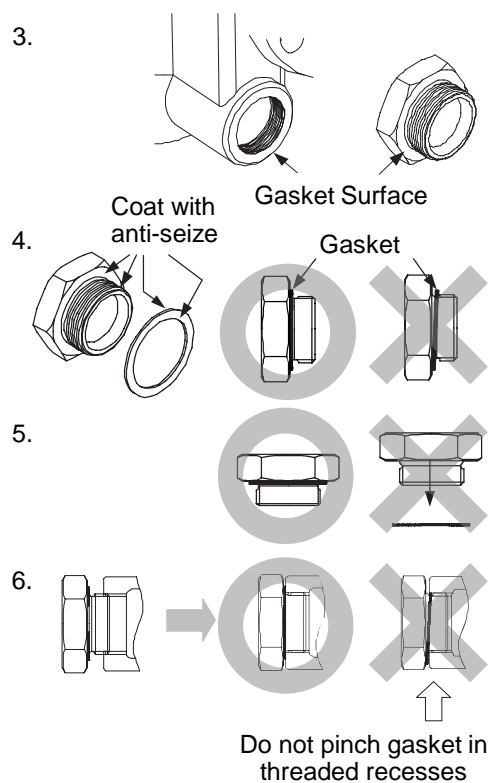

Troubleshooting



WARNING

NEVER apply direct heat to the float. The float may explode due to increased internal pressure, causing accidents leading to serious injury or damage to property and equipment.



CAUTION

When disassembling or removing the product, wait until the internal pressure equals atmospheric pressure and the surface of the product has cooled to room temperature. Disassembling or removing the product when it is hot or under pressure may lead to discharge of fluids, causing burns, other injuries or damage.

If the product fails to operate properly, use the following table to locate the cause and remedy.

Problem	Cause	Remedy
No condensate is discharged (blocked) or discharge is poor	The float is damaged or filled with condensate	Replace with a new float
	The orifice opening, screen or piping are clogged with rust and scale	Clean parts
	The bimetal is damaged	Replace with a new bimetal
	Steam locking has occurred	Perform a bypass blowdown, or close the trap inlet valve and allow the trap to cool
	The trap operating pressure exceeds the maximum specified pressure, or whether there is insufficient pressure differential between the trap inlet and outlet	Compare specifications and actual operating conditions
Steam is discharged or leaks from the outlet (blowing) (steam leakage)	Clogged orifice opening or rust and scale build-up beneath the float	Clean parts
	Scratches on the orifice	Replace with a new orifice
	The float is misshapen or has surface build-up	Clean or replace with a new float
	Improper installation orientation	Correct the installation
	Trap vibration	Lengthen the inlet piping and fasten it securely
	The bimetal air vent valve surface and/or the air vent valve seat has a build-up or is scratched	Clean or replace with a new bimetal and/or air vent valve seat
Steam is leaking from a place other than the outlet	The bimetal is damaged	Replace with a new bimetal
	Gasket deterioration or damage	Replace with new gasket(s)
Float frequently becomes damaged	Improper tightening torques were used	Tighten to the proper torque
	Water hammer has occurred	Study and correct the piping

NOTE: When replacing parts with new, use the parts list for reference, and replace with parts from the Maintenance Kit, Repair Kit, etc. Please note that replacement parts are only available as part of a replacement parts kit.

Product Warranty

1. Warranty Period
One year following product delivery.
2. Warranty Coverage
TLV CO., LTD. warrants this product to the original purchaser to be free from defective materials and workmanship. Under this warranty, the product will be repaired or replaced at our option, without charge for parts or labor.
3. This product warranty will not apply to cosmetic defects, nor to any product whose exterior has been damaged or defaced; nor does it apply in the following cases:
 - 1) Malfunctions due to improper installation, use, handling, etc., by other than TLV CO., LTD. authorized service representatives.
 - 2) Malfunctions due to dirt, scale, rust, etc.
 - 3) Malfunctions due to improper disassembly and reassembly, or inadequate inspection and maintenance by other than TLV CO., LTD. authorized service representatives.
 - 4) Malfunctions due to disasters or forces of nature.
 - 5) Accidents or malfunctions due to any other cause beyond the control of TLV CO., LTD.
4. Under no circumstances will TLV CO., LTD. be liable for consequential economic loss damage or consequential damage to property.

* * * * *

For Service or Technical Assistance:

Contact your TLV representative or your regional TLV office.

Manufacturer

TLV CO., LTD.
881 Nagasuna, Noguchi
Kakogawa, Hyogo 675-8511, JAPAN
Tel: 81-(0)79-427-1800

Options

The options shown below are available for this product on request. Please compare with the product you received.

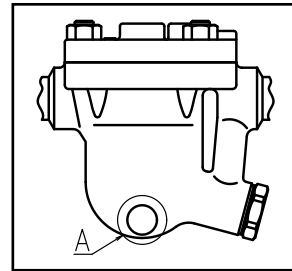

Options for Area A (standard: without drain plug)

With Drain Plug

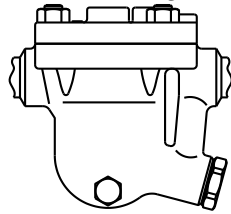

Torque		Distance Across Flats	
N·m	(lbf·ft)	mm	(in)
35	(26)	21	(¹³ / ₁₆)

(1 N·m ≈ 10 kg·cm)