



Instruction Manual

Steam Compressor System

SC1-3/SC2-3/SC7-3
SC1-3-2P/SC2-3-1P

Contents

Introduction	1
Safety Considerations	2
Specifications	4
Acceptable Operating Range	4
Correct Usage of the Steam Compressor System	5
Overview	7
Configuration	8
Installation	9
Operation	10
Maintenance.....	11
TLV EXPRESS LIMITED WARRANTY	12
Service	14

Introduction

Thank you for purchasing the TLV steam compressor system.

This product has been thoroughly inspected before being shipped from the factory. When the product is delivered, before doing anything else, check the specifications and external appearance to make sure nothing is out of the ordinary. Also be sure to read this manual carefully before use and follow the instructions to be sure of using the product properly.

Condensate from steam-using equipment still contains plenty of recoverable energy. In particular, when pressurized condensate is reduced to atmospheric pressure, flash steam is generated. By increasing the flash steam pressure to the steam-using equipment set pressure, flash steam can be utilized as a source of heat energy.

The TLV steam compressor system is a new system that enables the utilization of previously unused energy.





If detailed instructions for special order specifications or options not contained in this manual are required, please contact TLV for full details.

This instruction manual is intended for use with the model(s) listed on the front cover. It is needed not only for installation, but also for subsequent maintenance, disassembly and reassembly. Please keep it in a safe place for future reference.

Safety Considerations

- Read this section carefully before use and be sure to follow the instructions.
- Installation, inspection, maintenance, repairs, disassembly, adjustment and valve opening/closing should be carried out only by trained maintenance personnel.
- The precautions listed in this manual are designed to ensure safety and prevent equipment damage and personal injury. For situations that may occur as a result of erroneous handling, three different types of cautionary items are used to indicate the degree of urgency and the scale of potential damage and danger: DANGER, WARNING and CAUTION.
- The three types of cautionary items above are very important for safety: be sure to observe all of them as they relate to installation, use, maintenance and repair. Furthermore, TLV accepts no responsibility for any accidents or damage occurring as a result of failure to observe these precautions.

Symbols

	Indicates a DANGER, WARNING or CAUTION item.
	Indicates an urgent situation which poses a threat of death or serious injury
	Indicates that there is a potential threat of death or serious injury
	Indicates that there is a possibility of injury or equipment / product damage

	Install properly and DO NOT use this product outside the recommended operating pressure, temperature and other specification ranges. Improper use may result in such hazards as damage to the product or malfunctions that may lead to serious accidents. Local regulations may restrict the use of this product to below the conditions quoted.
	DO NOT use this product in excess of the maximum operating pressure differential. Such use could make discharge through the steam trap impossible (blocked).
	Use hoisting equipment for heavy objects (weighing approximately 20 kg (44 lb) or more). Failure to do so may result in back strain or other injury if the object should fall.
	Take measures to prevent people from coming into direct contact with product outlets. Failure to do so may result in burns or other injury from the discharge of fluids.

Continued on the next page

 CAUTION	<p>When disassembling or removing the product, wait until the internal pressure equals atmospheric pressure and the surface of the product has cooled to room temperature. Disassembling or removing the product when it is hot or under pressure may lead to discharge of fluids, causing burns, other injuries or damage.</p>
	<p>Be sure to use only the recommended components when repairing the product, and NEVER attempt to modify the product in any way. Failure to observe these precautions may result in damage to the product and burns or other injury due to malfunction or the discharge of fluids.</p>
	<p>Do not use excessive force when connecting threaded pipes to the product. Over-tightening may cause breakage leading to fluid discharge, which may cause burns or other injury.</p>
	<p>Use only under conditions in which no freeze-up will occur. Freezing may damage the product, leading to fluid discharge, which may cause burns or other injury.</p>
	<p>Use only under conditions in which no water hammer will occur. The impact of water hammer may damage the product, leading to fluid discharge, which may cause burns or other injury.</p>

Specifications



Install properly and **DO NOT** use this product outside the recommended operating pressure, temperature and other specification ranges. Improper use may result in such hazards as damage to the product or malfunctions which may lead to serious accidents. Local regulations may restrict the use of this product to below the conditions quoted.



DO NOT use this product in excess of the maximum operating pressure differential; such use could make discharge impossible (blocked).



Use only under conditions in which no freeze-up will occur. Freezing may damage the product, leading to fluid discharge, which may cause burns or other injury.

Refer to the product nameplate for detailed specifications.

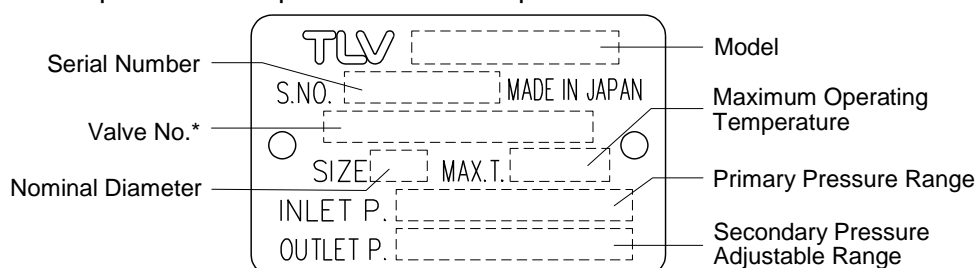

Maximum allowable pressure (PMA) and maximum allowable temperature (TMA) are PRESSURE SHELL DESIGN CONDITIONS, **NOT** OPERATING CONDITIONS.

Acceptable Operating Range

Model	SC1-3/SC1-3-2P	SC2-3/SC2-3-1P	SC7-3
Max. Operating Pressure (PMO)	2.0 MPaG (285 psig)		
Max. Operating Temperature (TMO)	220 °C (428 °F)		
Flow Rate Range	50 to 100% of rated flow rate at the outlet side		
Motive Steam Pressure Range	0.6 to 2.0 MPaG (87 to 285 psig)		
Applicable Fluid	Saturated Steam		
Max. Suction Steam Capacity* ¹	Refer to SC SDS for performance graphs		

*¹ Maximum suction steam capacity varies depending on pressure and temperature conditions, etc. (1 MPa = 10.197 kg/cm²)

For inspection and maintenance of other components or units, refer to individual instruction manuals.

Instruction manuals can be requested from TLV or accessed from the TLV website.

For steam compressor unit and steam compressor condensate recovery package:

- Control valve: CV10
- Check valve for steam compressor suction inlet pipe:
SC1, SC2: CK3MG; SC7: CKF3MG
NOTE: There is no coil spring in the check valve for the steam compressor suction inlet pipe. Except the coil spring, all components are identical to the standard check valve.
- Pressure sensor: MBS33M ¹⁾

For steam compressor condensate recovery package:

- GP system package: GP10-1CJ ^{1), 2)}
- Pressure reducing valve: S-COS-16

¹⁾ Contact TLV for details.

²⁾ Only available in some regions.

Correct Usage of the Steam Compressor System



Install properly and **DO NOT** use this product outside the recommended operating pressure, temperature and other specification ranges. Improper use may result in such hazards as damage to the product or malfunctions which may lead to serious accidents. Local regulations may restrict the use of this product to below the conditions quoted.

1. The steam compressor system should be operated only within its specifications.
2. Installing an automated valve (ON/OFF valve)

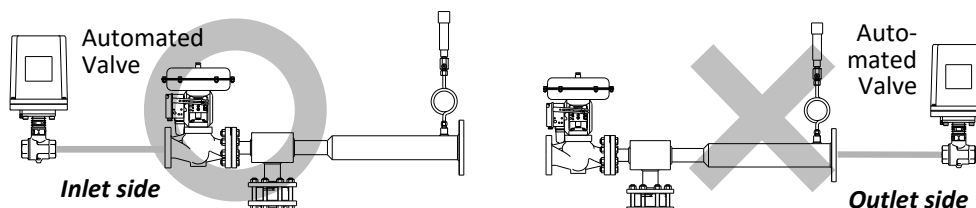

If an automated valve (on-off valve), such as a motorized valve or solenoid valve, is required to stop supply of steam to the steam-using equipment, install it at the motive inlet side of the steam compressor system. If an automated valve is installed at the discharge outlet of the steam compressor system, its opening and closing will cause heavy chattering.

To save energy, install the automated valve as near to the boiler as possible.

NOTE: To prevent water hammer, it is recommended that a slow-acting motorized valve be used. In particular, if a fast-acting solenoid valve is used for frequent temperature control, the potential water hammer effect can damage the steam-using equipment and the steam compressor system.

3. Installing a control valve

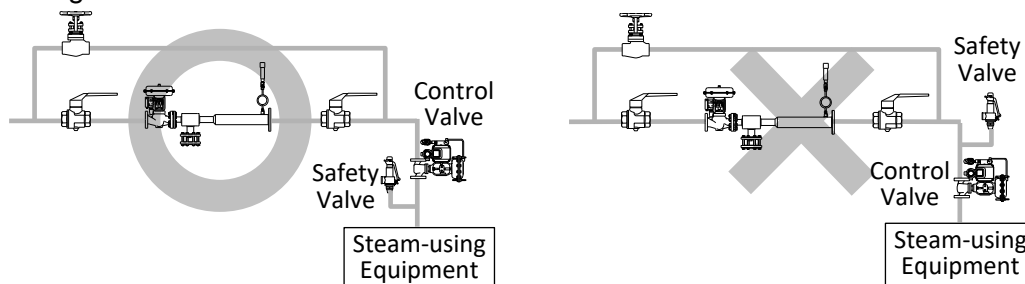

When a control valve installed at the secondary side of the steam compressor to control the temperature of the steam-using equipment, is throttled, the pressure may rise between the control valve and the steam compressor.

When installing a safety valve to protect the steam-using equipment, be sure to install it on the steam-using equipment or directly before the inlet of the steam-using equipment (between the equipment and control valve).

If the safety valve is installed between the control valve and steam compressor, an eventual pressure rise could activate the safety valve.

4. Precautions for the installation of additional fittings before or after the steam compressor system

In order to ensure stable steam flow, the piping upstream and downstream of the steam compressor system must be straight runs. If a steam compressor system is installed either directly before or after an elbow or control valve, unevenness in steam flow may result in chattering and unstable pressure.

To ensure stable steam flow, it is recommended that the steam compressor system be installed on straight runs of piping, as illustrated below.

1) Motive inlet (primary side) of the steam compressor system

NOTE: d = pipe diameter

Maintain a straight piping run of **10 d or more** when a manual valve, a strainer or an elbow, etc. is installed.

(Example: if nominal size is 25 mm (1 in), have 250 mm (10 in) or more)

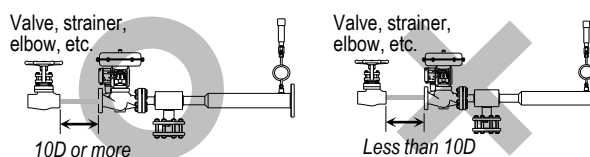

Maintain a straight piping run of **30 d or more** when an automated valve (on-off valve) is installed.

(Example: if nominal size is 25 mm (1 in), have 750 mm (30 in) or more)

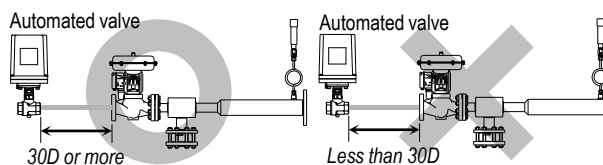

2) Discharge outlet (secondary side) of the steam compressor system

Maintain a straight piping run of **15 d or more** when a manual valve, a strainer or an elbow, etc. is installed.

(Example: if nominal size is 25 mm (1 in), have 375 mm (15 in) or more)

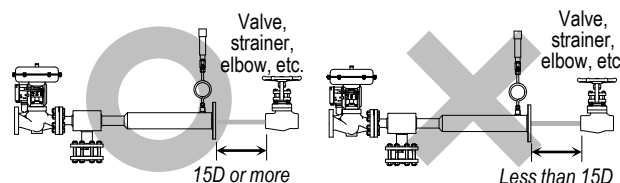

Maintain a straight piping run of **30 d or more** when a safety valve is installed.

(Example: if nominal size is 25 mm, have 750 mm (30 in) or more)

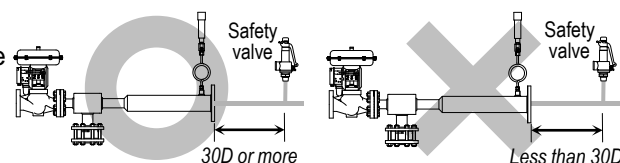

Maintain a straight piping run of **30 d or more** when another pressure reducing valve is installed. (Two-stage pressure reduction)

(Example: if nominal size is 25 mm (1 in), have 750 mm (30 in) or more)

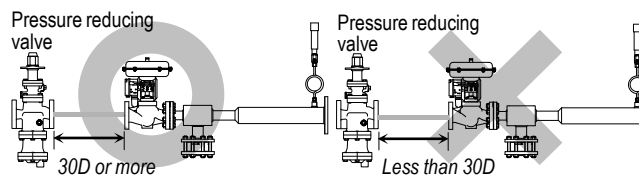

Maintain a straight piping run of **30 d or more** when a control valve or an automated valve (on-off valve) is installed.

(Example: if nominal size is 25 mm (1 in), have 750 mm (30 in) or more)

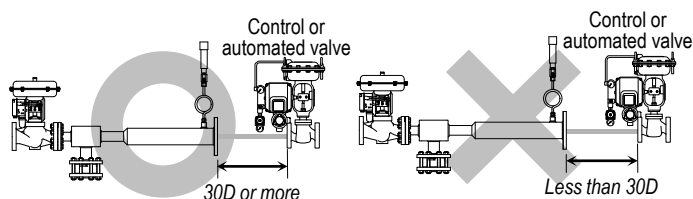

Overview

Steam Compressor Unit (Model: SC1-3/SC2-3)

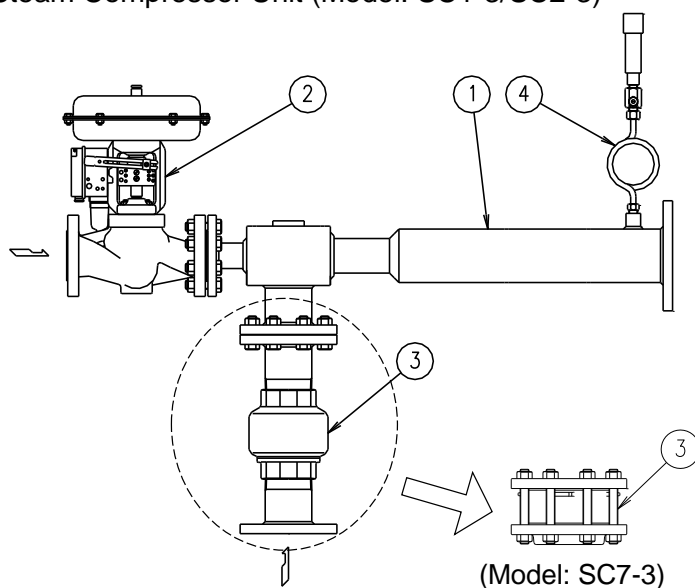

No	Name
1	Ejector
2	Control Valve
3	Check Valve
4	Pressure Transmitter

Steam Compressor Condensate Recovery Package (Model: SC1-3-2P/SC2-3-1P)

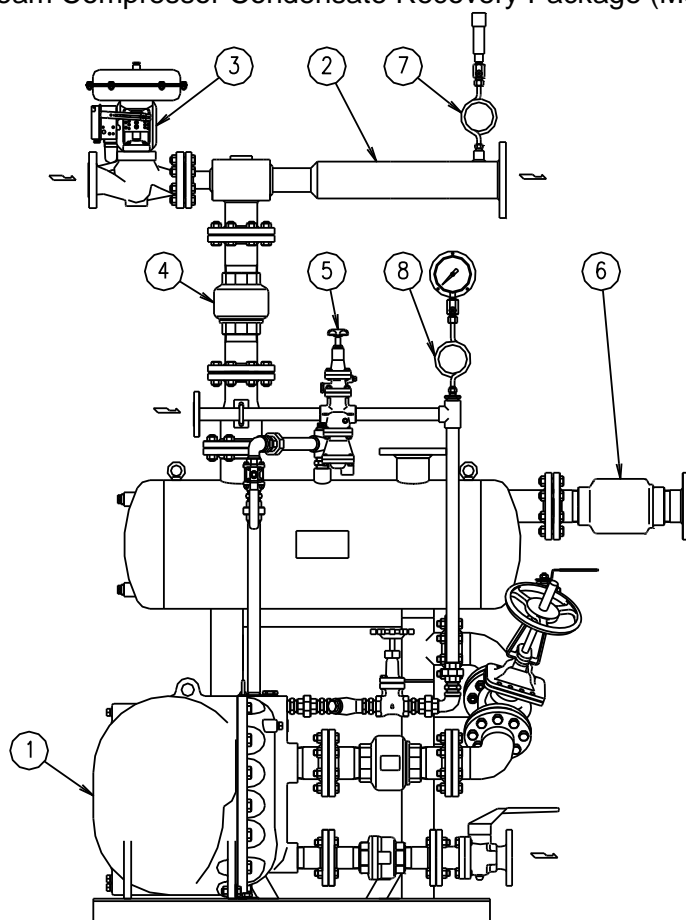

No.	Name
1	GP System Package
2	Ejector
3	Control Valve
4	Check Valve
5	Pressure Reducing Valve
6	Check Valve
7	Pressure Transmitter
8	Pressure Gauge

Configuration

(Model: SC1-3/SC2-3/SC7-3/SC1-3-2P/SC2-3-1P)

CV10 (Control Valve)

Size: SC1-3/SC1-3-2P: 25 mm (1 in); SC2-3/SC2-3-1P: 50 mm (2 in);
SC7-3: 80 mm (3 in)

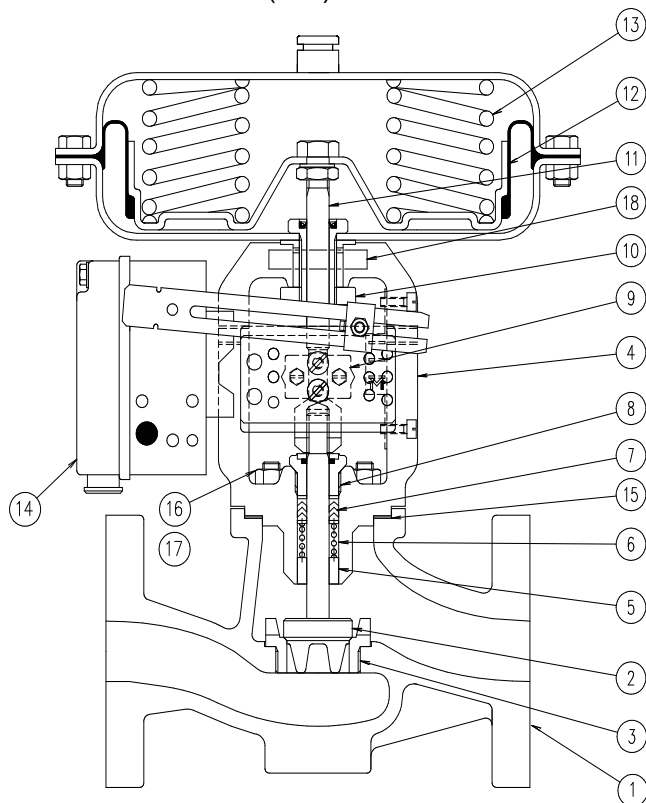

No.	Name
1	Body
2	Valve
3	Valve Seat
4	Bonnet
5	Guide Bushing
6	Coil Springs
7	V-rings
8	Gland Retainer
9	Connecting Support Plate
10	Fixing Nut
11	Actuator Stem
12	Bellowphragm
13	Coil Spring
14	Positioner
15	Bonnet Gasket
16	Stud Bolt
17	Nut
18	Nameplate

CK3MG (Check Valve for Suction Inlet Pipe on Steam Compressor)

Size: 80, 100 mm (3, 4 in)

For SC1/SC2
Size: 80 mm (3 in)

For SC7
Size: 100 mm (4 in)

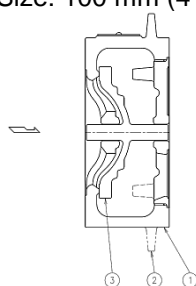
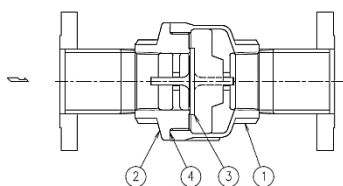

No.	Name
1	Body
2	Inlet Union
3	Valve Disc
4	Union Gasket

CK3MG-SC (Check Valve for Overflow Connection on Steam Compressor
Condensate Recovery Package)

Size: 80 mm (3 in)

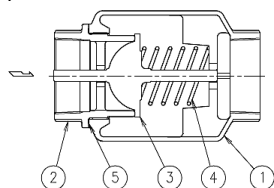

No.	Name
1	Body
2	Inlet Union
3	Valve Disc
4	Coil Spring
5	Union Gasket

Installation



Install properly and **DO NOT** use this product outside the recommended operating pressure, temperature and other specification ranges. Improper use may result in such hazards as damage to the product or malfunctions which may lead to serious accidents. Local regulations may restrict the use of this product to below the conditions quoted.



Use hoisting equipment for heavy objects (weighing approximately 20 kg (44lb) or more). Failure to do so may result in back strain or other injury if the object should fall.



Take measures to prevent people from coming into direct contact with product outlets. Failure to do so may result in burns or other injury from the discharge of fluids.

Installation, inspection, maintenance, repairs, disassembly, adjustment and valve opening/closing should be carried out only by trained maintenance personnel.

1. Blowdown

Before installing the steam compressor system, be sure to blow down all piping thoroughly. If this is not possible, perform a blowdown using the bypass valve. Blowdown is especially important for newly installed piping or after the system has been shut down for a long period of time.

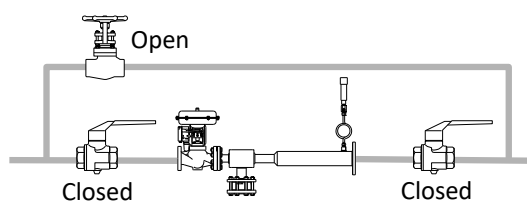

Blowdown using bypass valve

2. Removing seal and cap

Before installation, be sure to remove all protective seals. (Found in 3 locations, on the product inlets and outlet.)

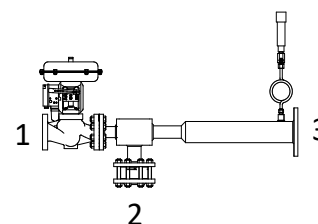

3. Piping support: Steam compressor unit

Install the steam compressor system, paying attention to avoid excessive load, bending and vibration. Support the motive inlet and discharge outlet pipes securely.

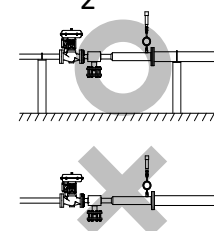

4. Piping support: Condensate Recovery System Package

Fix the base with the anchor bolts included with the package. For details, refer to the attached assembly drawing.

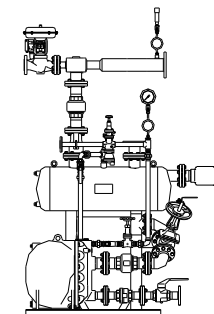

5. Maintenance space

Leave sufficient space for maintenance, inspection and repair. (Unit: mm (in))

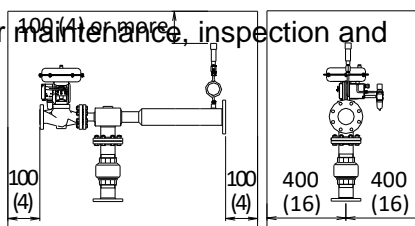

Operation



Install properly and **DO NOT** use this product outside the recommended operating pressure, temperature and other specification ranges. Improper use may result in such hazards as damage to the product or malfunctions which may lead to serious accidents. Local regulations may restrict the use of this product to below the conditions quoted.



Use only under conditions in which no freeze-up will occur. Freezing may damage the product, leading to fluid discharge, which may cause burns or other injury.



Use only under conditions in which no water hammer will occur. The impact of water hammer may damage the product, leading to fluid discharge, which may cause burns or other injury.

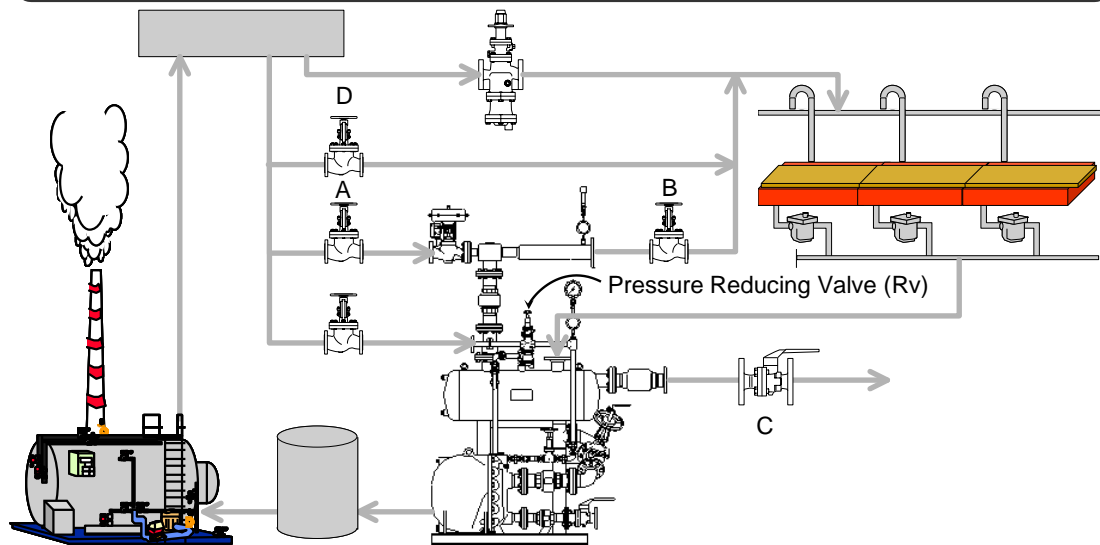

NOTE: This sketch is for explanation purposes only and is not intended as an installation design.

Follow the steps below to operate the steam compressor condensate recovery package.

1. Close valves A and B, and then slightly open valve C. When opening valve C, make sure that no personnel are present at the discharge location.
2. Slowly start steam supply from bypass valve D to discharge initial air from the steam line. Initial air in the piping accumulates in the condensate receiver tank of the system package, and is discharged from valve C.
3. When steam starts to be discharged from valve C, this means initial air is completely discharged.
4. Fully open valve B, and then slowly open valve A.
5. Set the pressure of the control valve on the steam compressor unit according to the controller (not included in the package or the unit).
6. Adjust the pressure reducing valve (Rv) on the system package and set the motive steam pressure for the mechanical pump.

NOTE: For operation of the steam compressor unit (model: SC^{*}-*), perform steps 4 and 5 only.

Maintenance



Take measures to prevent people from coming into direct contact with product outlets. Failure to do so may result in burns or other injury from the discharge of fluids.



Be sure to use only the recommended components when repairing the product, and NEVER attempt to modify the product in any way. Failure to observe these precautions may result in damage to the product or burns or other injury due to malfunction or the discharge of fluids.

Operational Check

To ensure long service life of the steam compressor system, the following inspection and maintenance should be performed regularly.

Ejector

Inspection Item	Inspection Method	Remedy for Failure (Malfunction)
Steam compressor performance	Flow rate confirmation, etc.: Steam compressor performance deteriorates. → Suction steam capacity is reduced, or steam is leaks from the check valve for the overflow connection of the condensate recovery package.	If other components such as the control valve, check valve, condensate recovery package (GP system package), etc. operate normally, remove the steam compressor from the piping to clean the interior. (See NOTE below.) →Narrow areas such as the reducer may be clogged. Clean the area with a long narrow brush, etc.

NOTE: When removing the steam compressor, wait until the internal pressure equals atmospheric pressure and the surface of the product has cooled to room temperature. Removing the product when it is hot or under pressure may cause burns, or other injuries.

When reattaching and retightening the bolts after cleaning, tighten them to the proper torque. Tightening torques differ depending on the gasket type used or the flange size. Make sure to confirm the proper tightening torque when retightening the bolts.

For inspection and maintenance of other components or units, refer to individual instruction manuals.

Instruction manuals can be requested from TLV or accessed from the TLV website.

For steam compressor unit and steam compressor condensate recovery package:

- Control valve: CV10
- Check valve for steam compressor suction inlet pipe:
SC1, SC2: CK3MG; SC7: CKF3MG

NOTE: There is no coil spring in the check valve for the steam compressor suction inlet pipe. Except the coil spring, all components are identical to the standard check valve.

- Pressure sensor: MBS33M ¹⁾

For steam compressor condensate recovery package:

- GP system package: GP10-1CJ ^{1), 2)}
- Pressure reducing valve: S-COS-16

¹⁾ Contact TLV for details.

²⁾ Only available in some regions.

TLV EXPRESS LIMITED WARRANTY

Subject to the limitations set forth below, TLV CO., LTD., a Japanese corporation (“**TLV**”), warrants that products which are sold by it, TLV International Inc. (“**TII**”) or one of its group companies excluding TLV Corporation (a corporation of the United States of America), (hereinafter the “**Products**”) are designed and manufactured by TLV, conform to the specifications published by TLV for the corresponding part numbers (the “**Specifications**”) and are free from defective workmanship and materials. The party from whom the Products were purchased shall be known hereinafter as the “**Seller**”. With regard to products or components manufactured by unrelated third parties (the “**Components**”), TLV provides no warranty other than the warranty from the third party manufacturer(s), if any.

Exceptions to Warranty

This warranty does not cover defects or failures caused by:

1. improper shipping, installation, use, handling, etc., by persons other than TLV, TII or TLV group company personnel, or service representatives authorized by TLV; or
2. dirt, scale or rust, etc.; or
3. improper disassembly and reassembly, or inadequate inspection and maintenance by persons other than TLV or TLV group company personnel, or service representatives authorized by TLV; or
4. disasters or forces of nature or Acts of God; or
5. abuse, abnormal use, accidents or any other cause beyond the control of TLV, TII or TLV group companies; or
6. improper storage, maintenance or repair; or
7. operation of the Products not in accordance with instructions issued with the Products or with accepted industry practices; or
8. use for a purpose or in a manner for which the Products were not intended; or
9. use of the Products in a manner inconsistent with the Specifications; or
10. use of the Products with Hazardous Fluids (fluids other than steam, air, water, nitrogen, carbon dioxide and inert gases (helium, neon, argon, krypton, xenon and radon)); or
11. failure to follow the instructions contained in the TLV Instruction Manual for the Product.

Duration of Warranty

This warranty is effective for a period of one (1) year after delivery of Products to the first end user. Notwithstanding the foregoing, asserting a claim under this warranty must be brought within three (3) years after the date of delivery to the initial buyer if not sold initially to the first end user.

ANY IMPLIED WARRANTIES NOT NEGATED HEREBY WHICH MAY ARISE BY OPERATION OF LAW, INCLUDING THE IMPLIED WARRANTIES OF MERCHANTABILITY AND FITNESS FOR A PARTICULAR PURPOSE AND ANY EXPRESS WARRANTIES NOT NEGATED HEREBY, ARE GIVEN SOLELY TO THE INITIAL BUYER AND ARE LIMITED IN DURATION TO ONE (1) YEAR FROM THE DATE OF SHIPMENT BY THE SELLER.

Exclusive Remedy

THE EXCLUSIVE REMEDY UNDER THIS WARRANTY, UNDER ANY EXPRESS WARRANTY OR UNDER ANY IMPLIED WARRANTIES NOT NEGATED HEREBY (INCLUDING THE IMPLIED WARRANTIES OF MERCHANTABILITY AND FITNESS FOR A PARTICULAR PURPOSE), IS **REPLACEMENT**; PROVIDED: (a) THE CLAIMED DEFECT IS

REPORTED TO THE SELLER IN WRITING WITHIN THE WARRANTY PERIOD, INCLUDING A DETAILED WRITTEN DESCRIPTION OF THE CLAIMED DEFECT AND HOW AND WHEN THE CLAIMED DEFECTIVE PRODUCT WAS USED; AND (b) THE CLAIMED DEFECTIVE PRODUCT AND A COPY OF THE PURCHASE INVOICE IS RETURNED TO THE SELLER, FREIGHT AND TRANSPORTATION COSTS PREPAID, UNDER A RETURN MATERIAL AUTHORIZATION AND TRACKING NUMBER ISSUED BY THE SELLER. ALL LABOR COSTS, SHIPPING COSTS, AND TRANSPORTATION COSTS ASSOCIATED WITH THE RETURN OR REPLACEMENT OF THE CLAIMED DEFECTIVE PRODUCT ARE SOLELY THE RESPONSIBILITY OF BUYER OR THE FIRST END USER. THE SELLER RESERVES THE RIGHT TO INSPECT ON THE FIRST END USER'S SITE ANY PRODUCTS CLAIMED TO BE DEFECTIVE BEFORE ISSUING A RETURN MATERIAL AUTHORIZATION. SHOULD SUCH INSPECTION REVEAL, IN THE SELLER'S REASONABLE DISCRETION, THAT THE CLAIMED DEFECT IS NOT COVERED BY THIS WARRANTY, THE PARTY ASSERTING THIS WARRANTY SHALL PAY THE SELLER FOR THE TIME AND EXPENSES RELATED TO SUCH ON-SITE INSPECTION.

Exclusion of Consequential and Incidental Damages

IT IS SPECIFICALLY ACKNOWLEDGED THAT THIS WARRANTY, ANY OTHER EXPRESS WARRANTY NOT NEGATED HEREBY, AND ANY IMPLIED WARRANTY NOT NEGATED HEREBY, INCLUDING THE IMPLIED WARRANTIES OF MERCHANTABILITY AND FITNESS FOR A PARTICULAR PURPOSE, DO NOT COVER, AND NEITHER TLV, TII NOR ITS TLV GROUP COMPANIES WILL IN ANY EVENT BE LIABLE FOR, INCIDENTAL OR CONSEQUENTIAL DAMAGES, INCLUDING, BUT NOT LIMITED TO LOST PROFITS, THE COST OF DISASSEMBLY AND SHIPMENT OF THE DEFECTIVE PRODUCT, INJURY TO OTHER PROPERTY, DAMAGE TO BUYER'S OR THE FIRST END USER'S PRODUCT, DAMAGE TO BUYER'S OR THE FIRST END USER'S PROCESSES, LOSS OF USE, OR OTHER COMMERCIAL LOSSES. WHERE, DUE TO OPERATION OF LAW, CONSEQUENTIAL AND INCIDENTAL DAMAGES UNDER THIS WARRANTY, UNDER ANY OTHER EXPRESS WARRANTY NOT NEGATED HEREBY OR UNDER ANY IMPLIED WARRANTY NOT NEGATED HEREBY (INCLUDING THE IMPLIED WARRANTIES OF MERCHANTABILITY AND FITNESS FOR A PARTICULAR PURPOSE) CANNOT BE EXCLUDED, SUCH DAMAGES ARE EXPRESSLY LIMITED IN AMOUNT TO THE PURCHASE PRICE OF THE DEFECTIVE PRODUCT. THIS EXCLUSION OF CONSEQUENTIAL AND INCIDENTAL DAMAGES, AND THE PROVISION OF THIS WARRANTY LIMITING REMEDIES HEREUNDER TO REPLACEMENT, ARE INDEPENDENT PROVISIONS, AND ANY DETERMINATION THAT THE LIMITATION OF REMEDIES FAILS OF ITS ESSENTIAL PURPOSE OR ANY OTHER DETERMINATION THAT EITHER OF THE ABOVE REMEDIES IS UNENFORCEABLE, SHALL NOT BE CONSTRUED TO MAKE THE OTHER PROVISIONS UNENFORCEABLE.

Exclusion of Other Warranties

THIS WARRANTY IS IN LIEU OF ALL OTHER WARRANTIES, EXPRESS OR IMPLIED, AND ALL OTHER WARRANTIES, INCLUDING BUT NOT LIMITED TO THE IMPLIED WARRANTIES OF MERCHANTABILITY AND FITNESS FOR A PARTICULAR PURPOSE, ARE EXPRESSLY DISCLAIMED.

Severability

Any provision of this warranty which is invalid, prohibited or unenforceable in any jurisdiction shall, as to such jurisdiction, be ineffective to the extent of such invalidity, prohibition or unenforceability without invalidating the remaining provisions hereof, and any such invalidity, prohibition or unenforceability in any such jurisdiction shall not invalidate or render unenforceable such provision in any other jurisdiction.

Service

For Service or Technical Assistance: Contact your TLV representative or your regional TLV office.

In Europe:

TLV EURO ENGINEERING GmbH

Daimler-Benz-Straße 16-18, 74915 Waibstadt, **Germany**

Tel: [49]-(0)7263-9150-0
Fax: [49]-(0)7263-9150-50

TLV EURO ENGINEERING UK LTD.

Units 7 & 8, Furlong Business Park, Bishops Cleeve, Gloucestershire GL52 8TW, **U.K.**

Tel: [44]-(0)1242-227223
Fax: [44]-(0)1242-223077

TLV EURO ENGINEERING FRANCE SARL

Parc d'Ariane 2, bât. C, 290 rue Ferdinand Perrier, 69800 Saint Priest, **France**

Tel: 33-(0)4-72482222
Fax: [33]-(0)4-72482220

In North America:

TLV CORPORATION

13901 South Lakes Drive, Charlotte, NC 28273-6790, **U.S.A.**

Tel: [1]-704-597-9070
Fax: [1]-704-583-1610

In Mexico and Latin America:

TLV ENGINEERING S. A. DE C. V.

Av. Jesús del Monte 39-B-1001, Col. Hda. de las Palmas, Huixquilucan, Edo. de México, 52763, **Mexico**

Tel: [52]-55-5359-7949
Fax: [52]-55-5359-7585

In Oceania:

TLV PTY LIMITED

Unit 8, 137-145 Rooks Road, Nunawading, Victoria 3131, **Australia**

Tel: [61]-(0)3-9873 5610
Fax: [61]-(0)3-9873 5010

In East Asia:

TLV PTE LTD

36 Kaki Bukit Place, #02-01/02, **Singapore** 416214

Tel: [65]-6747 4600
Fax: [65]-6742 0345

TLV SHANGHAI CO., LTD.

Room 5406, No. 103 Cao Bao Road, Shanghai, **China** 200233

Tel: [86]-(0)21-6482-8622
Fax: [86]-(0)21-6482-8623

TLV ENGINEERING SDN. BHD.

No.16, Jalan MJ14, Taman Industri Meranti Jaya, 47120 Puchong, Selangor, **Malaysia**

Tel: [60]-3-8065-2928
Fax: [60]-3-8065-2923

TLV PRIVATE LIMITED

252/94 (K-L) 17th Floor, Muang Thai-Phatra Complex Tower B, Rachadaphisek Road, Huaykwang, Bangkok 10310, **Thailand**

Tel: [66]-2-693-3799
Fax: [66]-2-693-3979

TLV INC.

#302-1 Bundang Technopark B, 723 Pangyo-ro, Bundang, Seongnam, Gyeonggi, 13511, **Korea**

Tel: [82]-(0)31-726-2105
Fax: [82]-(0)31-726-2195

In the Middle East:

TLV ENGINEERING FZCO

Building 2W, No. M002, PO Box 371684, Dubai Airport Free Zone, Dubai, **UAE**

Email: sales-me@tlv.co.jp

In Other Countries:

TLV INTERNATIONAL, INC.

881 Nagasuna, Noguchi, Kakogawa, Hyogo 675-8511, **Japan**

Tel: [81]-(0)79-427-1818
Fax: [81]-(0)79-425-1167

Manufacturer:

TLV CO., LTD.

881 Nagasuna, Noguchi, Kakogawa, Hyogo 675-8511, **Japan**

Tel: [81]-(0)79-422-1122
Fax: [81]-(0)79-422-0112