



Manufacturer

**TLV** CO., LTD.

Kakogawa, Japan

is approved by LRQA Ltd. to ISO 9001/14001



# Instruction Manual

## Motorized Pressure Reducing Valve for Steam **M-COSR-3/M-COSR-16/M-COSR-21**

Copyright © 2021 by TLV CO., LTD.

All rights reserved

## Contents

Introduction .....	1
Safety Considerations .....	2
Specifications .....	4
Acceptable Operating Range .....	6
Correct Usage of the M-COSR Motorized Pressure Reducing Valve .....	7
Configuration .....	9
Installation .....	11
Controller Operation .....	17
Maintenance .....	20
Disassembly .....	21
Reassembly .....	29
Troubleshooting .....	30
TLV EXPRESS LIMITED WARRANTY .....	33
Service .....	35

## Introduction

Thank you for purchasing the TLV M-COSR motorized pressure reducing valve for steam.

This product has been thoroughly inspected before being shipped from the factory. When the product is delivered, before doing anything else, check the specifications and external appearance to make sure nothing is out of the ordinary. Also be sure to read this manual carefully before use and follow the instructions to be sure of using the product properly.

The TLV M-COSR motorized pressure reducing valve for steam, model M-COSR is a high performance motor actuated remote type pressure reducing valve adding a remote control function to the TLV COSR pressure reducing valve. It can be easily adjusted by remote to supply steam to the process at the set pressure as needed without fluctuation.





If detailed instructions for special order specifications or options not contained in this manual are required, please contact TLV for full details.

This instruction manual is intended for use with the model(s) listed on the front cover. It is needed not only for installation, but also for subsequent maintenance, disassembly/reassembly and troubleshooting. Please keep it in a safe place for future reference.

## Safety Considerations

- Read this section carefully before use and be sure to follow the instructions.
- Installation, inspection, maintenance, repairs, disassembly, adjustment and valve opening/closing should be carried out only by trained maintenance personnel.
- The precautions listed in this manual are designed to ensure safety and prevent equipment damage and personal injury. For situations that may occur as a result of erroneous handling, three different types of cautionary items are used to indicate the degree of urgency and the scale of potential damage and danger: DANGER, WARNING and CAUTION.
- The three types of cautionary items above are very important for safety: be sure to observe all of them as they relate to installation, use, maintenance, and repair. Furthermore, TLV accepts no responsibility for any accidents or damage occurring as a result of failure to observe these precautions.

### Symbols

	<b>Indicates a DANGER, WARNING or CAUTION item.</b>
 <b>DANGER</b>	Indicates an urgent situation which poses a threat of death or serious injury
 <b>WARNING</b>	Indicates that there is a potential threat of death or serious injury
 <b>CAUTION</b>	Indicates that there is a possibility of injury or equipment/product damage
 <b>CAUTION</b>	<p><b>Install properly and DO NOT use this product outside the recommended operating pressure, temperature and other specification ranges.</b> Improper use may result in such hazards as damage to the product or malfunctions that may lead to serious accidents. Local regulations may restrict the use of this product to below the conditions quoted.</p> <p><b>Use hoisting equipment for heavy objects (weighing approximately 20 kg or more).</b> Failure to do so may result in back strain or other injury if the object should fall.</p> <p><b>Take measures to prevent people from coming into direct contact with product outlets.</b> Failure to do so may result in burns or other injury from the discharge of fluids.</p> <p><b>When disassembling or removing the product, wait until the internal pressure equals atmospheric pressure and the surface of the product has cooled to room temperature.</b> Disassembling or removing the product when it is hot or under pressure may lead to discharge of fluids, causing burns, other injuries or damage.</p>

Continued on the next page

 <b>CAUTION</b>	<p><b>Be sure to use only the recommended components when repairing the product, and NEVER attempt to modify the product in any way.</b> Failure to observe these precautions may result in damage to the product and burns or other injury due to malfunction or the discharge of fluids.</p>
	<p><b>Do not use excessive force when connecting threaded pipes to the product.</b> Over-tightening may cause breakage leading to fluid discharge, which may cause burns or other injury.</p>
	<p><b>Use only under conditions in which no freeze-up will occur.</b> Freezing may damage the product, leading to fluid discharge, which may cause burns or other injury.</p>
	<p><b>Use only under conditions in which no water hammer will occur.</b> The impact of water hammer may damage the product, leading to fluid discharge, which may cause burns or other injury.</p>
	<p><b>Make sure the power supply switch is OFF before carrying out work on the wiring or inspections involving disassembly.</b> If such work is carried out with the power on, there is a danger that equipment may malfunction or electric shock may occur, leading to injury or other accidents.</p>
	<p><b>Make sure that wiring work requiring a special license is carried out by qualified personnel.</b> If carried out by unqualified personnel, overheating or short circuits leading to injury, fires, damage or other accidents may occur.</p>
	<p><b>When using this product, NEVER stand close to, or leave tools anywhere near moving parts, such as the shaft.</b> Contact with moving parts or objects becoming caught in moving parts could lead to injury, damage or other accidents.</p>

## Specifications



Install properly and **DO NOT** use this product outside the recommended operating pressure, temperature and other specification ranges. Improper use may result in such hazards as damage to the product or malfunctions which may lead to serious accidents. Local regulations may restrict the use of this product to below the conditions quoted.



Use only under conditions in which no freeze-up will occur. Freezing may damage the product, leading to fluid discharge, which may cause burns or other injury.

### Valve

Refer to the product nameplate for detailed specifications.

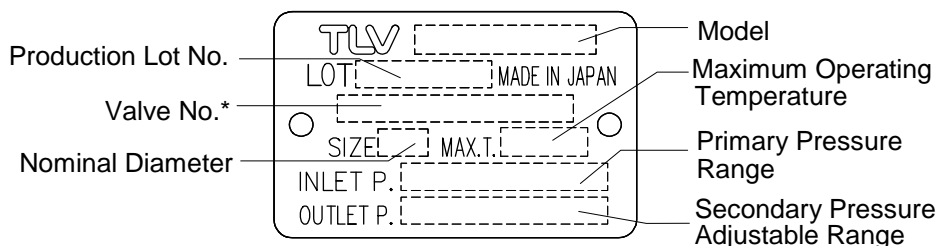

\* Valve No. is displayed for products with options. This item is omitted from the nameplate when there are no options.

### Actuator

<b>Model</b>		M-COSR-3/M-COSR-16/M-COSR-21
<b>Drive System</b>		ON/OFF control of reversible motor
<b>Line Voltage</b>		100/110 VAC $\pm$ 10% or 200/220 VAC $\pm$ 10% (50/60 Hz) (Supplied from controller) (Single phase)
<b>Power Consumption</b>		Included in Controller
<b>Withstand Voltage</b>		Between power terminal and ground terminal: 1800 VAC (60 Hz) for 1 second
<b>Insulation Resistance</b>		Between power terminal and ground terminal: Min. 100 M $\Omega$ (500 VDC)
<b>Operating Conditions</b>	Ambient Temperature	0 to 60 °C
	Water Resistance	JIS Rain-proof type (Motor must not come into contact with dew)
	Vibration Resistance	Max. 0.5 G
<b>Cable Heat Resistance</b>		70 °C (Cable must not come into contact directly with steam piping)
<b>Thermal Protection</b>		Motor with built-in 120 °C thermal protector
<b>Open/Close Time</b>		Approx. 40 seconds
<b>Continual Actuator Operation</b>		Approx. 5 minutes maximum
<b>Manual Operation</b>		Possible

## Controller

<b>Model</b>		MC-2
Pressure Display Function		Yes (select between displays of measured pressure and upper pressure)
Pressure Upper Limit Setting Function		Setting is possible
Power Source Voltage		100/110 VAC±10% or 200/220 VAC±10% (50 Hz/60 Hz)
Power Consumption	While motor is stopped	7 VA
	While motor is in operation	(TYP.) 65 VA (MAX.) 75 VA
Withstand Voltage		Between power terminal and ground terminal: 1800 VAC (60 Hz) for 1 second
Insulation Resistance		Between ground terminal and each terminal: Min. 100 MΩ (500 VDC)
Operating Conditions	Ambient Temperature	0 to 50 °C
	Ambient Humidity	5 – 90% RH (without dew), indoor use
	Vibration Resistance	Max. 0.5 G.
Dimensions (Unit: mm)		93 (W) × 184 (H) × 73 (D)
Weight		1.1 kg
Installation		Wall mounting (M5 screw × 4)
Material/Coating		Steel plate/black melamine
Pressure Indicator	Indication Range	0 – 1999kPaG
	Indication Accuracy	±0.5%F.S.
	Pressure Sensor	Standard type
	Allowable Pressure Setting Range	0 to 1999 kPaG

## Pressure Sensor

### ● Standard type

Model	M-COSR-3	M-COSR-16/M-COSR-21
Pressure Measurement Range	0 to 0.5 MPaG (500 kPaG) type	0 – 2.0 MPaG type 0 – 0.5 MPaG (500 kPaG) type*1
Signal Output	4 to 20 mA DC (load resistance 250 Ω/15 VDC)	
Measurement Accuracy	±0.3%F.S.	
Temperature Drift	±0.02%F.S./°C	
Maximum Allowable Pressure	2 times the maximum value of the measurement range	
Ambient Temperature	–40 to +85 °C (Sensor must not come into contact with dew)	
Water Resistance	JIS Rain-proof type	
Material for Wetted Parts	AISI 316 / DIN W. No. 1.4401	
Connection Thread	G (PF) <sup>3</sup> / <sub>8</sub>	
Weight	Approx. 400 g	
Accessories	Siphon Tube (connector screw for piping installation end: R(PT) <sup>3</sup> / <sub>8</sub> )	

\*1When the secondary pressure is 0.03 MPaG or less, choose a 0 to 0.5 MPaG (500 kPaG) type sensor

## Acceptable Operating Range

Model	M-COSR-3	M-COSR-16	M-COSR-21
Primary Pressure Range	0.1 to 0.3 MPaG	0.2 to 1.6 MPaG	1.35 to 2.1 MPaG
Secondary Pressure Adjustable Pressure Range (All conditions must be met)	0.01 to 0.05 MPaG	Within 10 to 84% of the primary pressure	
		Minimum adjustable pressure of 0.03 MPaG	Minimum adjustable pressure of 0.55 MPaG
		Pressure differential between 0.07 to 0.85 MPa	Maximum pressure differential of 0.85 MPa
Minimum Adjustable Flow Rate	5% of rated flow rate	5% of rated flow rate; 10% of rated flow rate for sizes 65 to 150 mm	5% of rated flow rate; 10% of rated flow rate for sizes 65 to 100 mm

## Correct Usage of the M-COSR Motorized Pressure Reducing Valve



Install properly and **DO NOT** use this product outside the recommended operating pressure, temperature and other specification ranges. Improper use may result in such hazards as damage to the product or malfunctions which may lead to serious accidents. Local regulations may restrict the use of this product to below the conditions quoted.

1. The M-COSR should be operated only within its specifications.
2. Installing an ON/OFF Valve (Solenoid Valve or Motorized Valve)

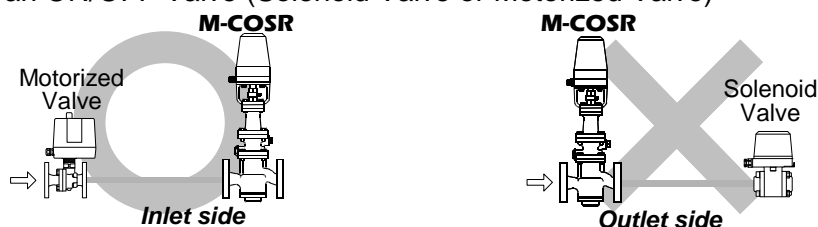

If an on-off valve, such as a motorized valve, is required to stop supply of steam to the steam-using equipment, install it at the inlet side of the M-COSR. If a solenoid valve is installed at the outlet of the M-COSR, its opening and closing will cause heavy chattering and may lead to damage of the piston and main valve. (When the on-off valve opens, the secondary pressure of the M-COSR changes from zero to the set pressure. Passing through an area of the reducing ratio of less than 10:1, where adjustment is impossible, and chattering occurs momentarily. To save energy, install the on-off valve as near to the boiler as possible.)

**NOTE:** To prevent water hammer, it is recommended that a slow-acting motorized on-off valve be used. In particular, if a fast-acting on-off solenoid valve is used for frequent temperature control, the potential water hammer effect can damage the steam-using equipment and the M-COSR.

3. Installing a Control Valve

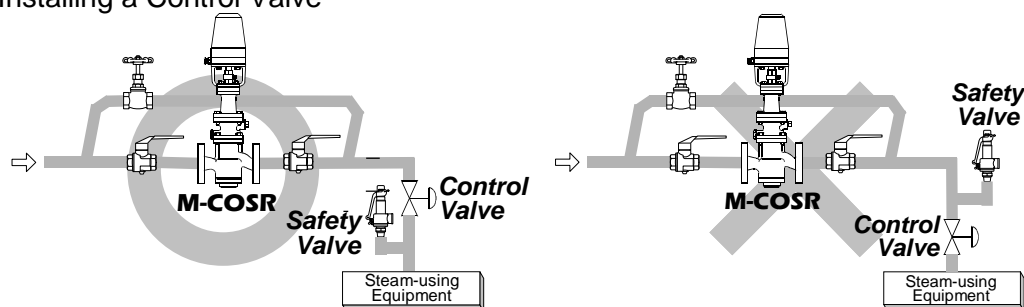

A control valve installed between the M-COSR and the steam-using equipment (downstream of the M-COSR) for controlling equipment temperature may raise the pressure between the M-COSR and the control valve when the control valve is closed, depending on the spatial relationship. A safety valve should be installed downstream of the control valve.

**NOTE:** When installing a safety valve to protect the steam-using equipment, be sure to install it on the steam-using equipment or directly before the inlet of the steam-using equipment. If the safety valve is installed on the outlet side of the M-COSR between the M-COSR and a control valve, an eventual pressure rise could activate the safety valve.



4. Precautions for the Installation of Additional Fittings Before or After the M-COSR  
 In order to ensure stable steam flow, the piping upstream and downstream of the M-COSR must be straight runs. If a M-COSR is installed either directly before or after an elbow or control valve, unevenness in steam flow may result in chattering and unstable pressure.

To ensure stable steam flow, it is recommended that the M-COSR be installed on straight runs of piping, as illustrated below.

(1) Inlet (primary side) of the M-COSR

$d$  = pipe diameter

Maintain a straight piping run of **10 d or more** when a manual valve, a strainer or an elbow, etc. is installed.

(Example: if nominal size is 25 mm, have 250 mm or more)

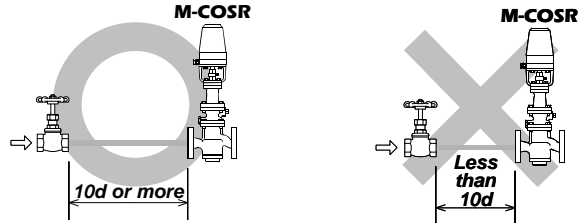

Maintain a straight piping run of **30 d or more** when an automated valve (on-off valve) is installed.

(Example: if nominal size is 25 mm, have 750 mm or more)

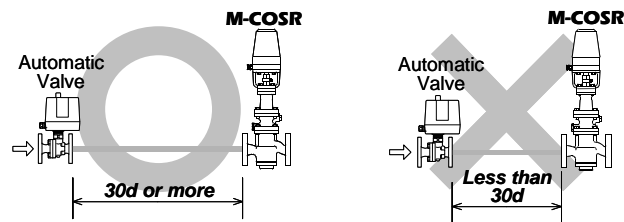

(2) Outlet (secondary side) of the M-COSR

Maintain a straight piping run of **15 d or more** when a manual valve, a strainer or an elbow, etc. is installed.

(Example: if nominal size is 25 mm, have 375 mm or more)

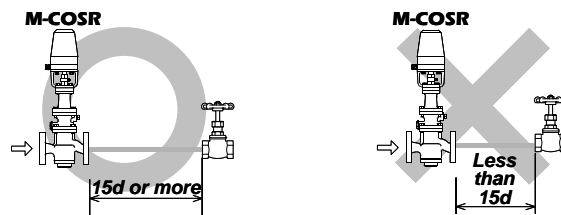

Maintain a straight piping run of **30 d or more** when a safety valve is installed.

(Example: if nominal size is 25 mm, have 750 mm or more)

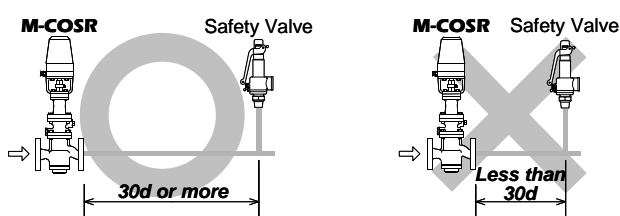

Maintain a straight piping run of **30 d or more** when another pressure reducing valve is installed. (Two-stage pressure reduction)

(Example: if nominal size is 25 mm, have 750 mm or more)

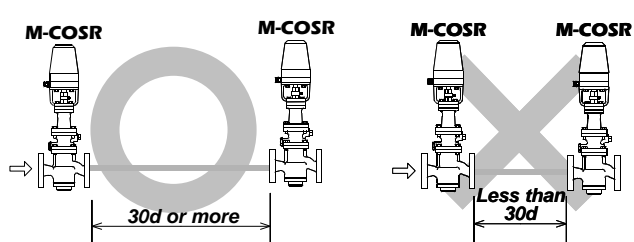

Maintain a straight piping run of **30 d or more** when a control valve or an automated valve (on-off valve) is installed.

(Example: if nominal size is 25 mm, have 750 mm or more)

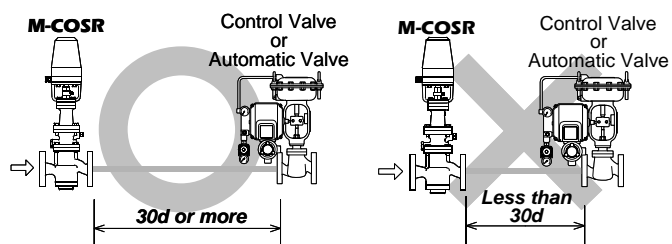

## Configuration

15 – 50 mm

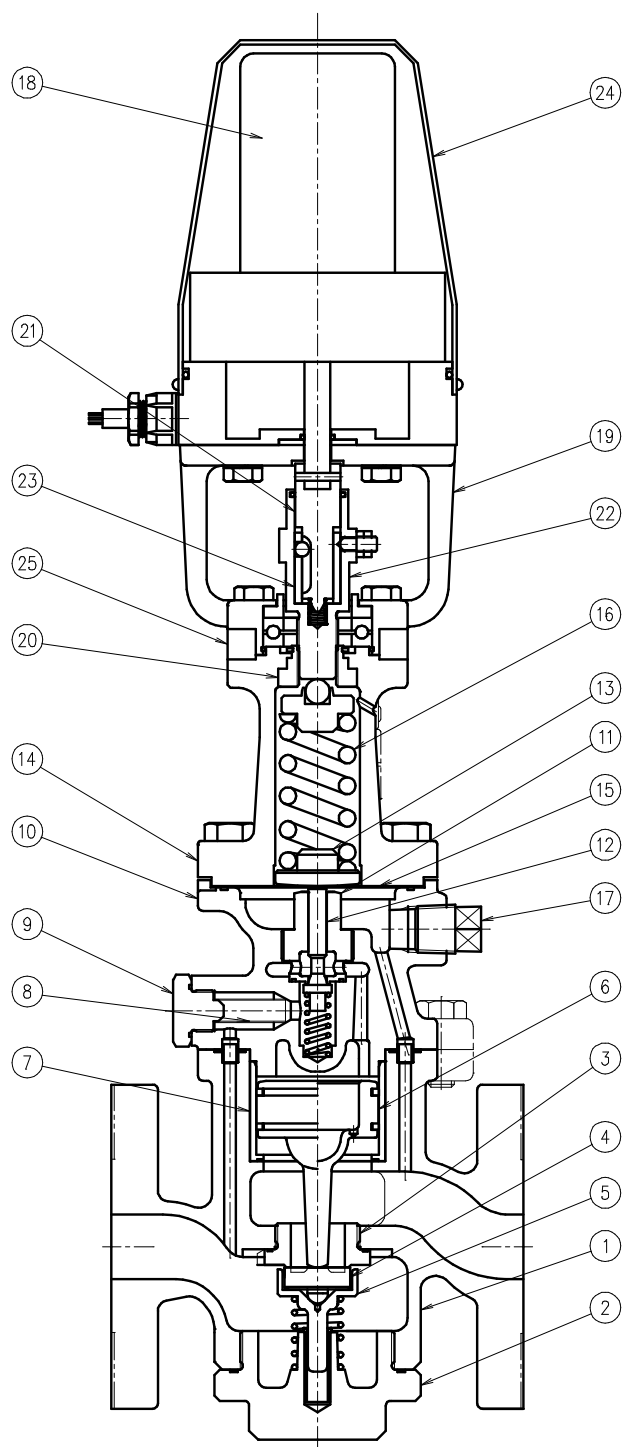

No.	Name
1	Main Body
2	(Main Body) Plug
3	Main Valve Seat
4	Main Valve
5	Main Valve Holder
6	Piston
7	Cylinder
8	Pilot Screen
9	Pilot Screen Holder
10	Pilot Body
11	Pilot Valve Seat
12	Pilot Valve
13	Diaphragm Support
14	Spring Housing
15	Diaphragm
16	Coil Spring
17	Plug – Sensing Line Port
18	Motor Unit (Actuator)
19	Mounting Plate
20	Adjustment Screw Guide
21	Splined Shaft
22	Adjustment Screw
23	Sleeve
24	Motor Cover
25	Insulation Plate

65 – 150 mm

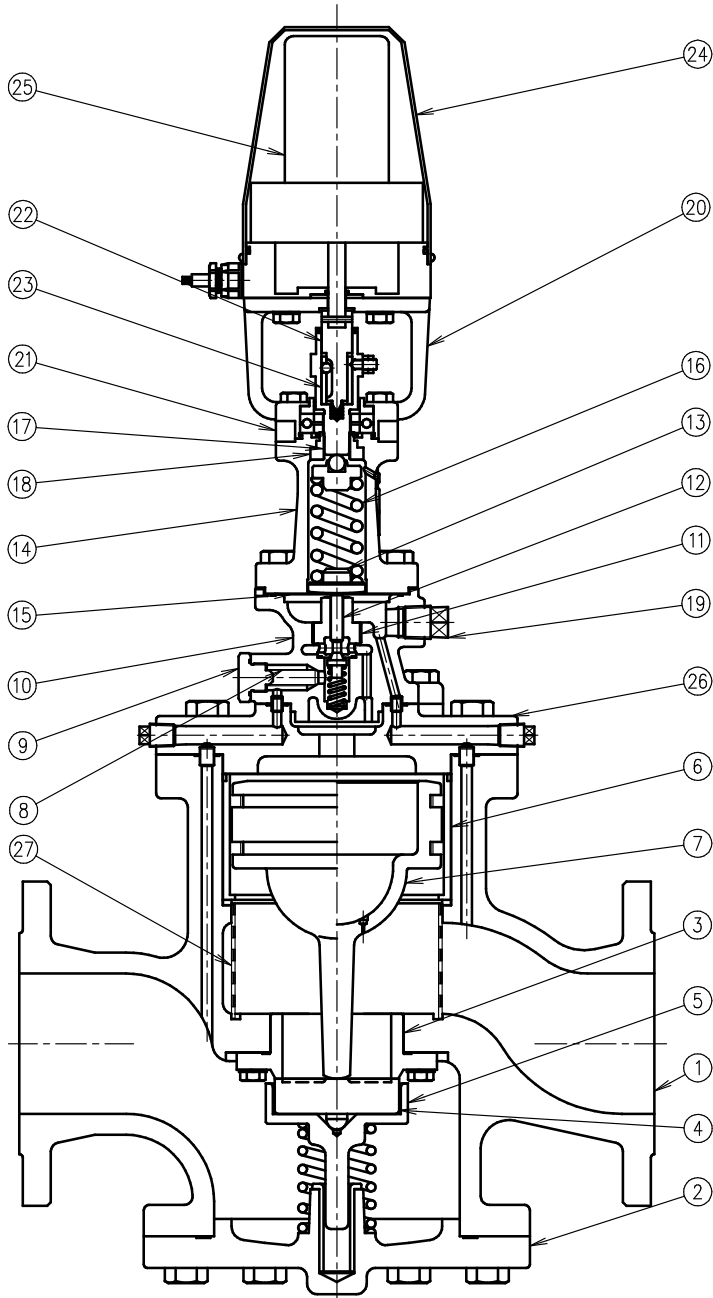

No.	Name
1	Main Body
2	(Main Body) Cover
3	Main Valve Seat
4	Main Valve
5	Main Valve Holder
6	Cylinder
7	Piston
8	Pilot Screen
9	Pilot Screen Holder
10	Pilot Body
11	Pilot Valve Seat
12	Pilot Valve
13	Diaphragm Support
14	Spring Housing
15	Diaphragm
16	Coil Spring
17	Adjustment Screw
18	Adjustment Screw Guide
19	Plug – Sensing Line Port
20	Mounting Plate
21	Insulation Plate
22	Splined Shaft
23	Sleeve
24	Motor Cover
25	Motor Unit (Actuator)
26	Pilot Cover
27	Silencer

## Installation



Install properly and **DO NOT** use this product outside the recommended operating pressure, temperature and other specification ranges. Improper use may result in such hazards as damage to the product or malfunctions which may lead to serious accidents. Local regulations may restrict the use of this product to below the conditions quoted.



Use hoisting equipment for heavy objects (weighing approximately 20 kg or more). Failure to do so may result in back strain or other injury if the object should fall.



Take measures to prevent people from coming into direct contact with product outlets. Failure to do so may result in burns or other injury from the discharge of fluids.



Make sure the power supply switch is **OFF** before carrying out work on the wiring or inspections involving disassembly. If such work is carried out with the power on, there is a danger that equipment may malfunction or electric shock may occur, leading to injury or other accidents.



Make sure that wiring work requiring a special license is carried out by qualified personnel. If carried out by unqualified personnel, overheating or short circuits leading to injury, fires, damage or other accidents may occur.



When using this product, **NEVER** stand close to, or leave tools anywhere near moving parts, such as the shaft. Contact with moving parts or objects becoming caught in moving parts could lead to injury, damage or other accidents.

Installation, inspection, maintenance, repairs, disassembly, adjustment and valve opening/closing should be carried out only by trained maintenance personnel.

### 1. Blowdown

Before installing the M-COSR, be sure to blowdown all piping thoroughly. If this is not possible, perform a blowdown using the bypass valve. Blowdown is especially important for newly installed piping or after the system has been shut down for a long period of time.

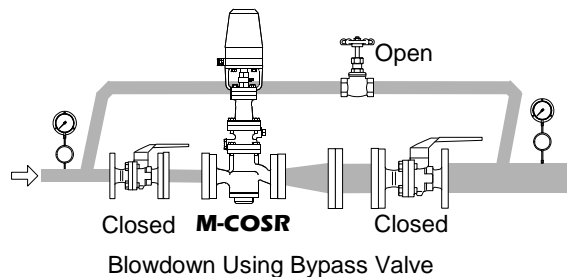

### 2. Removing Seal and Cap

Before installation, be sure to remove all protective seals and caps. (Found in 2 locations, on the product inlet and outlet.)

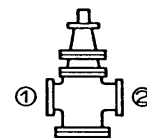

### 3. Installation Angle

Install the M-COSR vertically, so that the arrow mark on the body points horizontally in the direction of steam flow. Allowable inclination is 10 degrees in the fore-aft direction and 15 degrees in the plane perpendicular to the steam flow line.

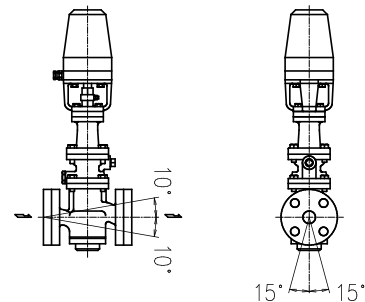

4. Spacer Installation

If spacing adjustment is necessary to accommodate installation, install a spacer on the outlet flange. The spacer should consist of a spacer, gaskets, bolts and nuts. Fit gaskets to both sides of the spacer between the M-COSR outlet and the pipe flange. Fasten with bolts and nuts.

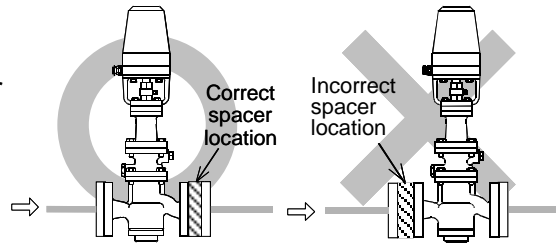

5. Piping Support

Install the M-COSR, paying attention to avoid excessive load, bending and vibration. Support the inlet and outlet pipes securely.

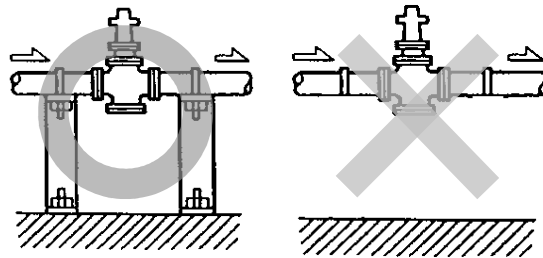

6. Maintenance Space

Leave sufficient space for maintenance, inspection and repair.

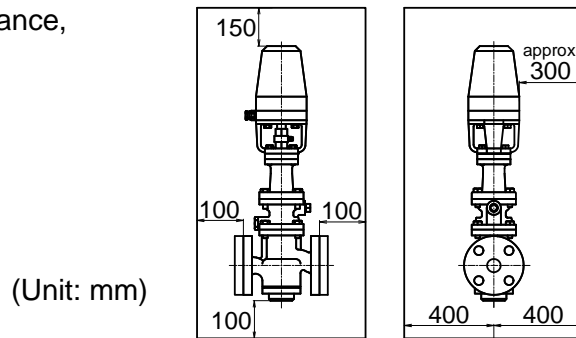

7. Piping Size/Diffuser

If it is expected that the secondary steam flow velocity will be more than 30 m/s, install a diffuser in order to keep the flow velocity below 30 m/s. If the distance between the M-COSR and the steam-using equipment is great, a possible drop in pressure should be taken into consideration when selecting the piping size.

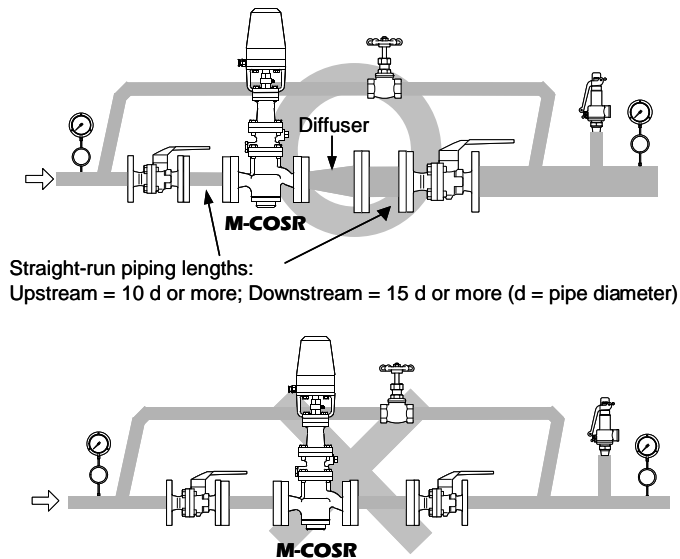

## 8. Two-stage Pressure Reduction

Two-stage pressure reduction should be performed whenever the pressure cannot be reduced to the desired level with a single M-COSR due to operating range limitations, such as when the reduction ratio is greater than 10:1.

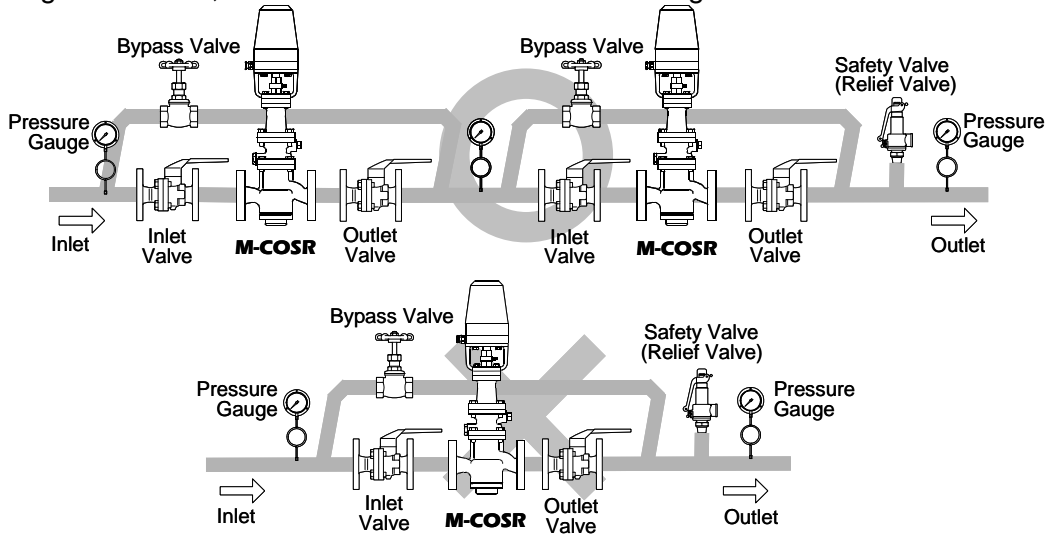

## 9. Accessories

Always install a shut-off valve, pressure gauge and bypass lines at both inlet and outlet.

Ball valves, which will not retain condensate, are recommended for inlet and outlet shut-off valves. The bypass pipe should be at least  $\frac{1}{2}$  of the size of the inlet (primary side) pipe.

In case an external strainer is installed, it should be installed ahead of M-COSR and the strainer should be 60 mesh or finer, but not so fine as to constrict flow resulting in a pressure drop. The strainer should be installed horizontally with the basket at the 3 or 9 o'clock position in order to prevent condensate accumulation.

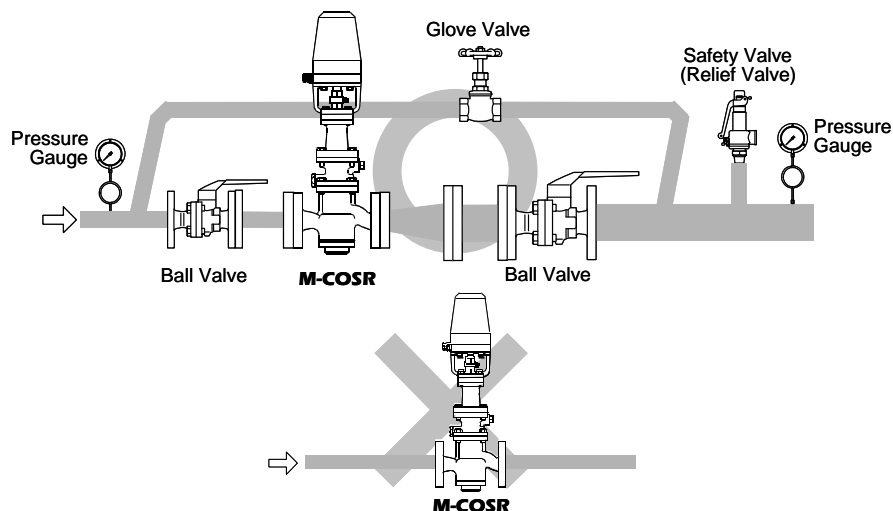

#### 10. Installation of the Controller Unit

Mount the controller unit securely on a wall, etc. with self-tapping screws inserted in the holes.

The controller is not waterproof. Be sure to install it indoors in a suitable protected area.

The ambient temperature range specified for the normal operation of the unit is between 0 and 50 °C. Avoid operation beyond this specified range.

Install the controller unit in a suitable place with low humidity and vibration.

#### 11. Installation of the Pressure Sensor

Install the pressure sensor on or near the steam-using equipment on the piping. Arrange the piping as perpendicularly as practical with the siphon tube supplied. (Direct mounting of the sensor to the equipment or to the piping may result in damage to the pressure sensor due to conduction of heat.)

**NOTE:** The pressure sensor is made to withstand a maximum pressure of 2 times the maximum value of the measurement range.

If there is a possibility that excessive pressure beyond this limit will be applied to the sensor due to water hammer or otherwise, consult our sales staff before continuing the installation.

#### 12. External secondary pressure-sensing line (when required)

**North American Models** are factory prepared for external sensing.

An external sensing line **MUST** be installed.

**DO NOT SUPPLY STEAM** until all piping and a 10 mm secondary pressure sensing line with a slightly falling pitch have been properly installed. Install a shutoff valve in the pressure sensing line for maintenance purposes.



**Keep the shutoff valve open at all times during operation. If the shutoff valve is closed, M-COSR will fully open and PRIMARY PRESSURE WILL BE SUPPLIED TO THE EQUIPMENT (see "Piping Example" on next page).**

#### **Non-North American Models:**

Factory-standard M-COSR employs an internal secondary pressure-sensing channel built into the body, saving the need to install an external pressure-sensing line to detect the secondary pressure.

Installation of an external secondary pressure-sensing line involves closing the internal pressure-sensing channel and installing a line from the sensing line port to the point where pressure should be controlled. This can increase stability of pressure control where steam loss in secondary piping and flow rate fluctuation is high. In addition, the rated flow rate will be greater than an internal pressure-sensing channel under the operational pressure reduction ratio of 2:1 or more.

Installation procedure

- 1) Loosen and remove the bolts that attach the pilot body to the main body (15 – 50 mm) or the pilot cover (65 – 150 mm) and remove the pilot body.
- 2) Install the blind pin (optional) by first removing the connecting tube from the main body or pilot cover and then substituting the blind pin.
- 3) Re-install the pilot body and fasten the bolts evenly to the proper torque.
- 4) Remove the plug and connect the secondary pressure sensing line.
- 5) Install the secondary pressure sensing line with a slightly falling pitch. The end of the secondary pressure sensing line should be connected to the place on the main piping where the pressure is to be sensed (see the piping example on next page). A shut-off valve and union should be installed in the secondary pressure sensing line.

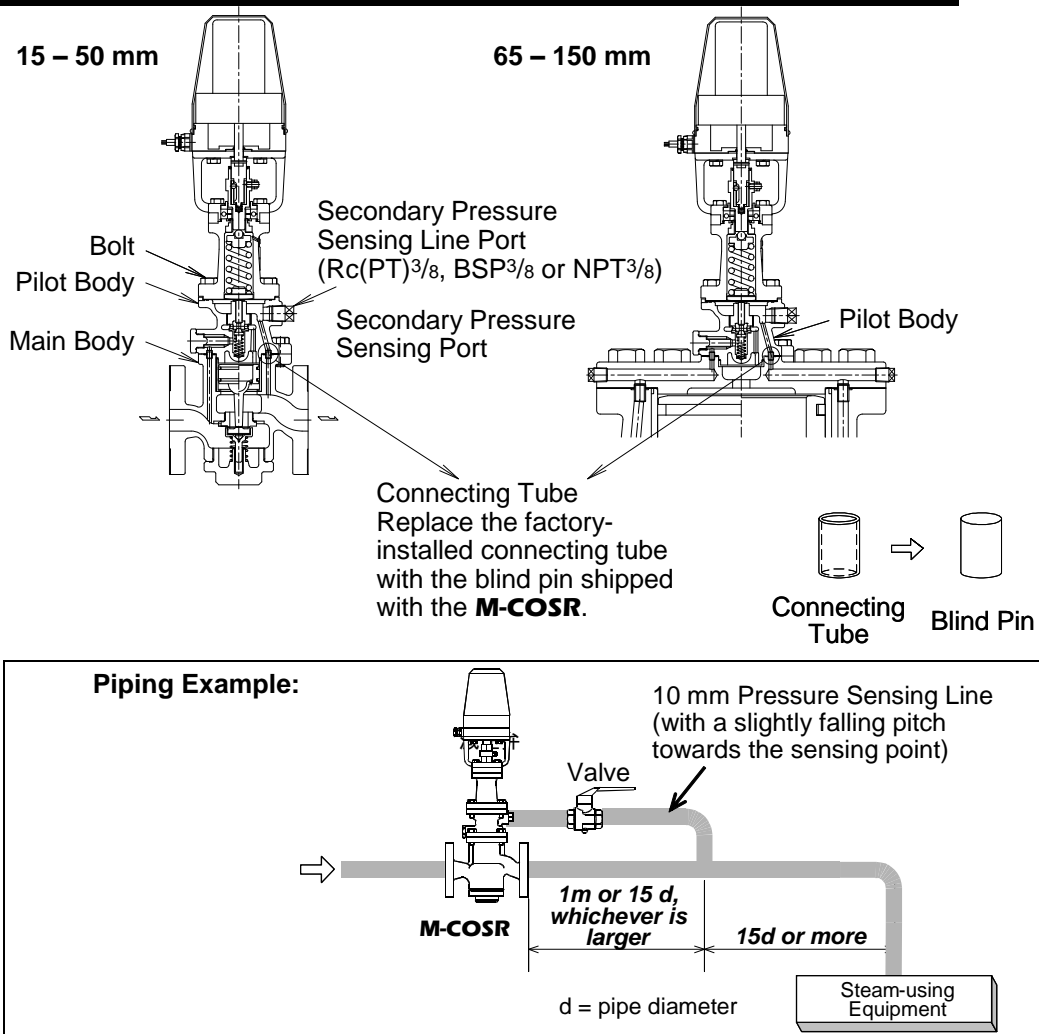

### 13. Internal sensing for North American models

All models except North American models are factory prepared for internal sensing. When internal pressure sensing is required for North American models, please contact the nearest TLV representative to request both a connecting tube, which must be installed in place of the blind pin, and a threaded secondary pressure sensing plug.\* Follow the connecting tube installation procedure shown below:

- 1) Loosen and remove the four (4) bolts that attach the pilot body to the main body (15 – 50 mm) or the pilot cover (65 – 150 mm), and remove the pilot body.
- 2) Install the connecting tube by first removing the blind pin from the secondary side of the main body or pilot cover and then substituting the connecting tube.
- 3) Re-install the pilot body and fasten the four (4) bolts evenly.

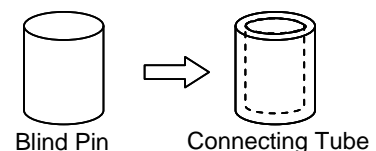

Consult page 29 in this manual for torque requirements of these bolts.

- 4) If a secondary pressure sensing pipe has previously been installed, remove it and be certain to install the threaded secondary pressure sensing line plug in its place.

\*Internal sensing should not be used when 15 mm and 20 mm M-COSR-16 will be used below 0.3 MPaG and 0.1 MPaG respectively, and below 50% of primary pressure.



## Wiring

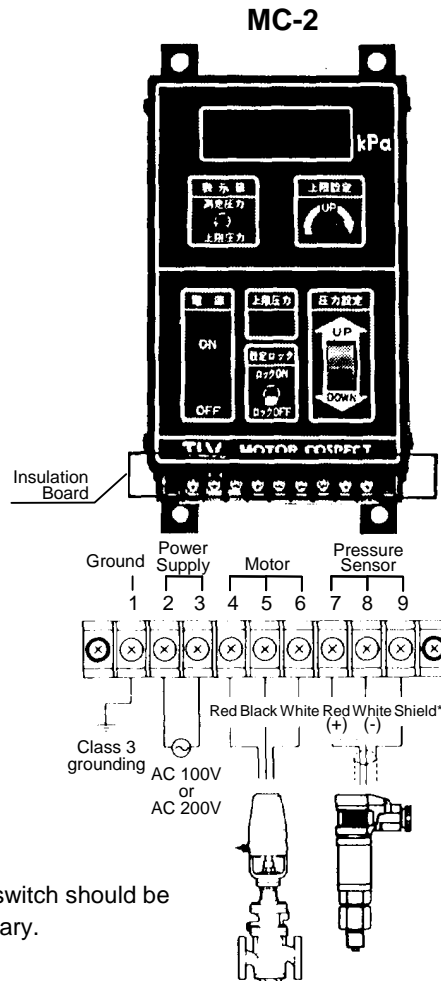

1. Before arranging wiring, check the correct supply voltage values specified for the controller unit and for the actuator (motor) once again.
2. Connections of the wires to the terminal board must be made securely with insulated pressure-connection terminals.
3. To ensure safety, be sure to ground the controller unit and the actuator.  
Grounding requirements: Class 3 grounding or better  
(Use mild steel wires of 2 mm<sup>2</sup> (AWG 14) or larger size and of 100 Ω or less resistance, extending up to 20 m.)
4. Wiring should be routed in the shortest distance practical, located at least 0.5 m away from other pieces of equipment that can be noise-generating sources. Wiring should never contact any exposed steam piping.  
Cables used for wiring shall be as follows:
 

Power Cable	: min. 0.5 mm <sup>2</sup> (AWG 20) × 2-core
Motor Cable	: min. 0.5 mm <sup>2</sup> (AWG 20) × 3-core
Pressure Sensor	: min. 0.5 mm <sup>2</sup> (AWG 20) × 2-core shielded wire

 NOTE: Wiring for the shielded wire should be made only on the controller side and not on the pressure sensor side.  
(Shielded wire should never contact the pressure sensor case.)
5. To allow access for maintenance, provide 100 mm of clearance around the actuator when arranging wiring.
6. Upon completion of wiring to the terminal board, fit the supplied insulation board and fix it in securely in place.

## Controller Operation

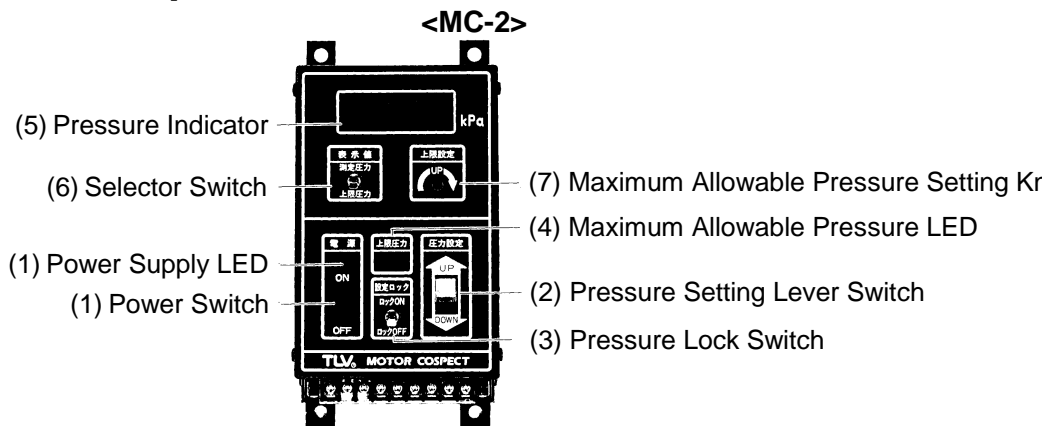

### Part Names and Features

NOTE: Pressure values in parentheses ( ) are for the 500 kPa (0.5 MPaG) model.

#### (1) Power Switch/Power Supply LED

This is the main switch for the entire controller unit. By turning ON the power switch, the power supply LED is lit to indicate that power is supplied to the unit.

#### (2) Pressure Setting Lever Switch

This switch is used for adjusting steam pressure. By pushing the lever switch toward the UP side, the pressure-adjustment screw in the M-COSR unit is pushed in (rotates clockwise from top-down view), causing the secondary pressure to rise. Conversely, by pushing it toward the DOWN side, the pressure-adjustment screw is pulled back (rotates counterclockwise from top-down view) causing the pressure to fall. (By releasing your hand, the switch returns to the OFF condition.)

NOTE: **Do not operate the lever switch continuously for more than 5 minutes.**

If the motor is run beyond that limit, the thermal protector for the motor is activated to bring the motor to a standstill. (Motor condition is restored to normal when the motor has cooled.)

#### (3) Pressure Lock Switch

When the pressure lock switch is turned to “LOCK ON”, the pressure setting lever switch becomes inoperative.

When the “set pressure” valve is to be fixed at a certain level, turn this switch ON. Then, even if the set pressure lever switch is operated by mistake, the set value will not change. (Turn the pressure lock switch OFF if it is desired to change the set value.)

#### (4) Maximum Allowable Pressure LED

The LED lights up when the maximum allowable pressure switch is activated. Once the pressure switch LED is ON, the UP side of the pressure setting lever switch becomes inoperative, thereby disabling setting of pressures higher than that which has been set on the pressure switch.

(If it is desired to set the upper limit pressure for the protection of the steam-using equipment, connect a suitable pressure switch externally.)

## (5) Pressure Indicator

LED in the pressure indicator window lights up when the power switch (1) is turned ON indicating either the measured pressure or the maximum allowable pressure, depending on the setting on the selector switch (6).

Values available for indication are between 000 to 1999 kPa (500 kPa).

Pressure indicator shows about -500 (-125) on the measured pressure side when the pressure sensor is not connected. When the measured pressure exceeds 1999 kPa, the display shows 1\*\*\*.

## (6) Selector Switch

This switch is used for selecting the desired pressure indication item (5).

Indication of measured pressure values is selected by pushing the switch upward, and the maximum allowable pressure is selected when it is pushed downward.

Normally the selector switch is set at the measured pressure indication side.

## (7) Maximum Allowable Pressure Setting Knob

This knob is used to set the maximum allowable pressure to protect the steam-using equipment against damage. By setting the selector switch (6) at the maximum allowable pressure, the set maximum allowable pressure is indicated. The maximum allowable pressure setting is increased by turning the knob clockwise, and it is decreased by turning it counterclockwise.

Setting for the maximum allowable pressure is possible as desired within a range from 0 to 1999 (500 kPa).

If, after setting the maximum allowable pressure, the measured pressure should rise to that limit, the internal pressure switch is triggered making the pressure setting lever switch (2) inactive, thus preventing pressure from rising further.

At that moment, the maximum allowable pressure LED (4) lights up indicating that the pressure switch has been activated.

The pressure setting lever switch (2) has become inactive at the UP side only; the DOWN side can be operated.

If it is desired to cancel this action, shift the lever switch to the DOWN side and lower the level of measured pressure by at least 30 (10) kPa from the maximum allowable pressure, thereby turning the maximum allowable pressure LED (4) OFF. The action of the pressure switch is released, restoring the UP side to the normal operative condition. The UP side of the lever switch remains inoperative so long as the maximum allowable pressure LED (4) remains ON.

NOTE: When no setting is made for the maximum allowable pressure, the upper limit value should be set at least 100 (50) kPa higher than the maximum value allowed for pressure setting.

The upper limit pressure is set at around 1800 (400) kPa at the time of shipment.

## Operation Procedures

1. Turn ON the power to the controller. (Thereupon, LEDs for power ON and for the pressure indicator are lighted).  
Make sure that the pressure lock switch is turned OFF.
2. Set the maximum allowable pressure.  
With the selector switch set at the maximum allowable pressure side, operate the maximum allowable pressure setting knob to set the desired maximum allowable pressure. When no setting is made for the upper limit, set at a value equivalent to the maximum set pressure plus 100 kPa.  
When the setting has been completed, shift the selector switch to the measured pressure side.
3. Set the pressure with the pressure setting lever switch.  
While reading the measured value given on the pressure indicator, adjust the pressure setting by pushing the lever switch either toward the UP side (if the pressure is to be raised), or toward the DOWN side (if it is to be lowered). In order to avoid possibly overshooting the desired set value if the switch is pressed continuously, retract the switch temporarily to a point 20 to 50 kPa before the target pressure, and thereafter, set by fine adjustment to the exact desired pressure. As long as the pressure setting lever switch is depressed, the pressure setting value continues changing at a rate of about 20 to 40 kPa per second. Use this as the guideline in case there is a delay in the change of the pressure indication due to a large volume of steam space, for example.
 

Where the maximum allowable pressure has been set, if the pressure rises to that maximum allowable pressure, the internal pressure switch is activated (the allowable maximum pressure LED is lighted). The UP side of the lever switch becomes inactive, inhibiting further adjustment for the UP side until the measured pressure has fallen below the maximum allowable pressure setting by at least 30 kPa (whereupon the maximum allowable pressure LED light goes out).
4. If the set value is to be fixed, upon completion of the setting, turn ON the pressure lock switch and keep it at the ON condition. Then, the set value will not change even if the pressure set lever switch is operated by mistake. If it is desired to change the set value, first turn OFF the lock switch and then operate the pressure setting lever switch.

## Manual Operation

If automatic controlled operation via the controller becomes impossible due to a power failure or otherwise, switch over to manual operation by the following method:

Using a wrench, turn the hexagon portion of the pressure-adjustment screw below the actuator (distance across flats: 24 mm).  
(Required tightening torque: Max. 5 N·m)

Pressure increased by turning clockwise (from top view).

Pressure falls by turning counterclockwise.

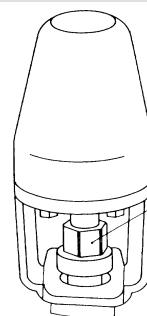

Hexagon part of pressure-adjustment screw distance across flats: 24mm

## Maintenance

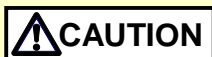

Take measures to prevent people from coming into direct contact with product outlets. Failure to do so may result in burns or other injury from the discharge of fluids.



Be sure to use only the recommended components when repairing the product, and NEVER attempt to modify the product in any way. Failure to observe these precautions may result in damage to the product or burns or other injury due to malfunction or the discharge of fluids.



Make sure the power supply switch is OFF before carrying out work on the wiring or inspections involving disassembly.  
If such work is carried out with the power on, there is a danger that equipment may malfunction or electric shock may occur, leading to injury or other accidents.

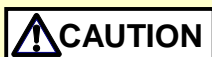

Make sure that wiring work requiring a special license is carried out by qualified personnel.  
If carried out by unqualified personnel, overheating or short circuits leading to injury, fires, damage or other accidents may occur.



When using this product, NEVER stand close to, or leave tools anywhere near moving parts, such as the shaft.  
Contact with moving parts or objects becoming caught in moving parts could lead to injury, damage or other accidents.

## Operational Check

To ensure long service life of the M-COSR, the following inspection and maintenance should be performed regularly.

Part	Inspection and Maintenance Frequency
Pilot Screen	Disassemble and clean annually. If there is substantial blockage, install a strainer (approximately 60 mesh) ahead of the M-COSR.
Main Valve, Main Valve Seat, Pilot Valve and Pilot Valve Seat	Replace after approximately 15,000 hours. If there is chattering or dirt, premature wear may result.
Piston Ring	Replace after approximately 8,000 hours. If there is chattering or if scale build-up is severe, premature wear may result.
Piston	Replace after approximately 30,000 hours. If hunting or chattering takes place, premature wear may result.
Diaphragm	Replace after approximately 30,000 hours. If hunting or chattering takes place, cracks or fatigue may develop in a short period of time.

## Disassembly



Use hoisting equipment for heavy objects (weighing approximately 20 kg or more). Failure to do so may result in back strain or other injury if the object should fall.



When disassembling or removing the product, wait until the internal pressure equals atmospheric pressure and the surface of the product has cooled to room temperature. Disassembling or removing the product when it is hot or under pressure may lead to discharge of fluids, causing burns, other injuries or damage.



Make sure the power supply switch is OFF before carrying out work on the wiring or inspections involving disassembly. If such work is carried out with the power on, there is a danger that equipment may malfunction or electric shock may occur, leading to injury or other accidents.



Make sure that wiring work requiring a special license is carried out by qualified personnel. If carried out by unqualified personnel, overheating or short circuits leading to injury, fires, damage or other accidents may occur.

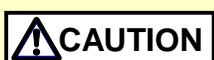

When using this product, NEVER stand close to, or leave tools anywhere near moving parts, such as the shaft. Contact with moving parts or objects becoming caught in moving parts could lead to injury, damage or other accidents.

It is a recommended practice to dismantle and inspect the M-COSR once a year for preventive maintenance purposes. It is especially important to perform an inspection immediately after the initial run of a new line or before or after equipment such as a heater is out of service for a long period of time. (Installation, inspection, maintenance, repairs, disassembly, adjustment and valve opening/closing should be carried out only by trained maintenance personnel.)

Remove all steam from the piping (both upstream and downstream).

Putting the actuator to work, let the pressure adjusting screw pull up to establish the free condition. (The adjustment screw can be fully pulled up by pressing the pressure setting lever switch (on the controller) to the DOWN side and holding it there for about one minute.)

Disconnect the actuator wiring.

Wait for the body to cool before attempting to remove the M-COSR from the line. Then remove inlet and outlet flange retaining bolts and nuts to permit removal of the M-COSR. Secure the M-COSR in a vise to perform the inspection.

<Valve>

**Disassembling the Pilot Section**

The diaphragm is removed by utilizing the notch in the pilot body. Loosen the pilot valve seat with a box wrench and remove it. Lift the pilot valve spring up and out with a pair of tweezers. Then loosen and remove the pilot screen holder to remove the pilot screen.

→Check for any fault on the pilot valve seat, flaws on the gaskets and clogging of the pilot screen.

Check for deformation, corrosion or faults on the diaphragm. The diaphragm should be convex (open downward), with the printed "UP" mark on the top.

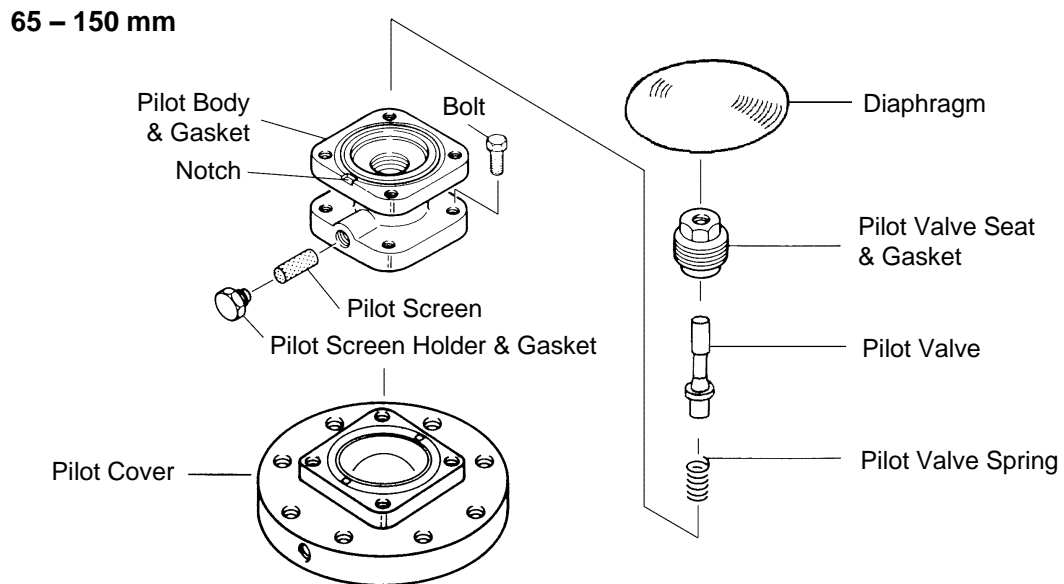
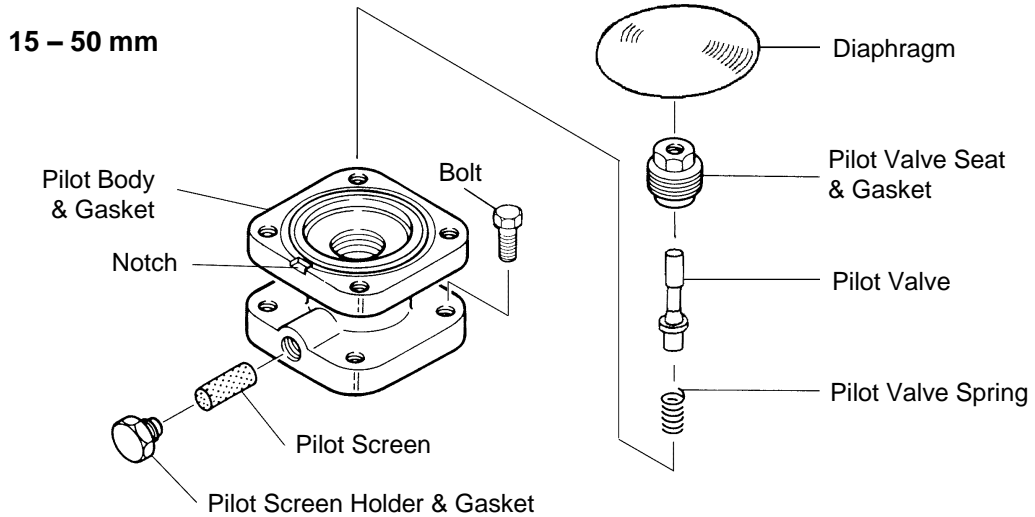

## Disassembling the Piston Section

Remove the pilot body after loosening and removing the bolts.  
During this process, pay attention not to lose the connecting tubes (2).

Remove the piston, cylinder and the silencer (for 65 to 150 mm only) from the main body. Then remove the piston rings and the tension rings from the piston. Do not apply too much force when removing the piston rings and tension rings. Next remove the screen (65 to 150 mm only).

→Check for the interior of the cylinder, the exterior of the piston rings, the small hole on the piston and the gaskets for any fault or abnormality.

### 15 – 50 mm

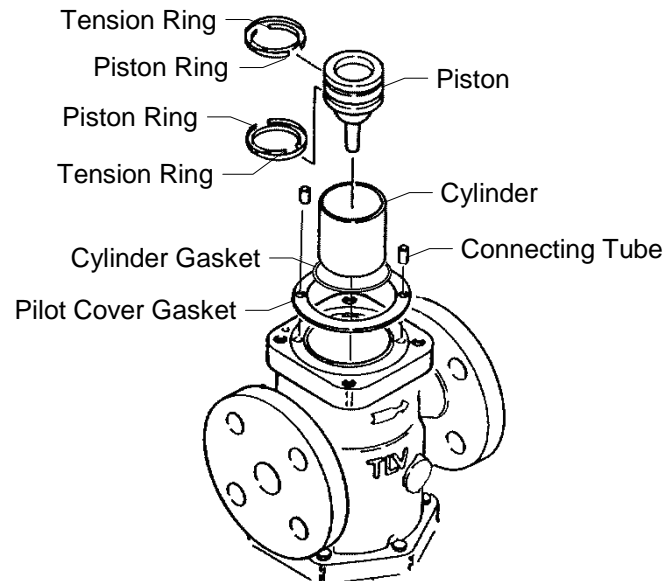

### 65 – 150 mm

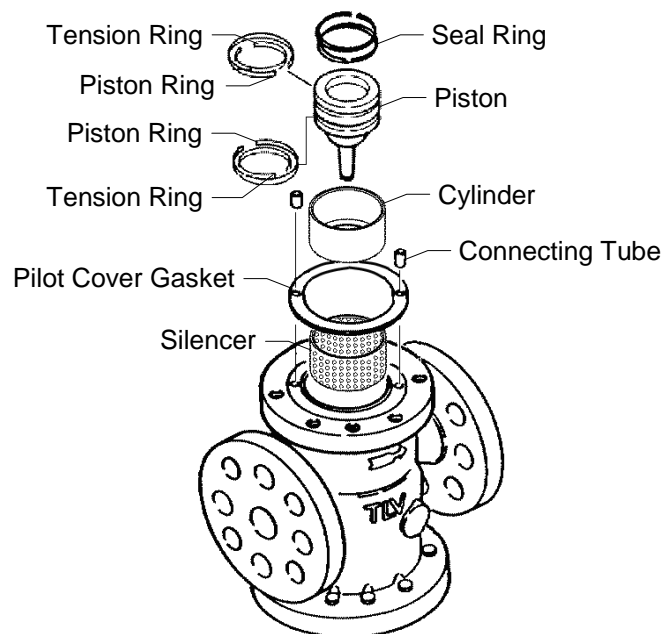



## Disassembling the Main Body and Main Valve Section

Turn the M-COSR upside down for easy dismantling of the main valve.

Remove the cover plug or loosen the bolts and remove the cover. Remove the main valve spring, main valve and the main valve holder. Loosen the main valve seat with a box wrench and remove it from the main body.

→Check for damage on the seating and sliding surfaces of the main valve and main valve holder, the seating surface of the main valve seat.

**M-COSR-3: 20, 25 mm**  
**M-COSR-16: 15 – 25 mm**

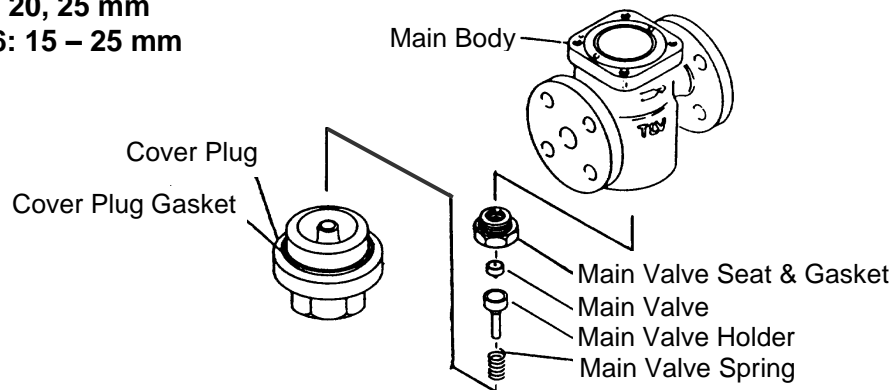

**M-COSR-3/16: 32 – 50 mm**  
**M-COSR-21: 15 – 50 mm**

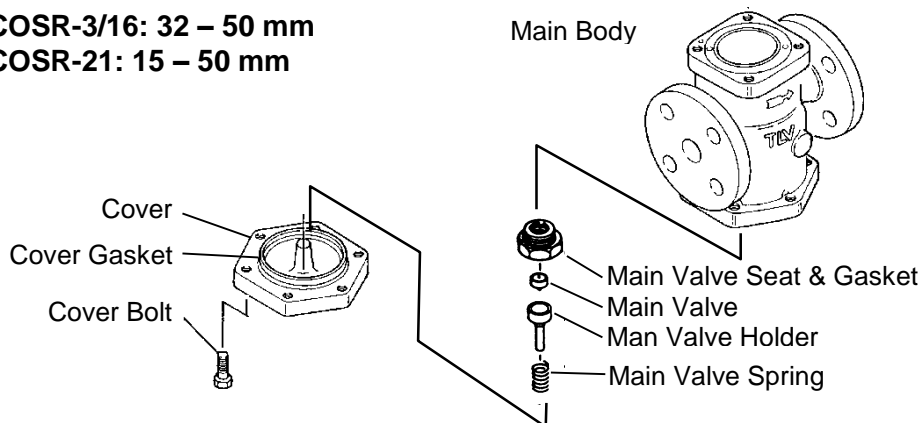

**M-COSR-16: 65 – 150 mm**  
**M-COSR-21: 65 – 100 mm**

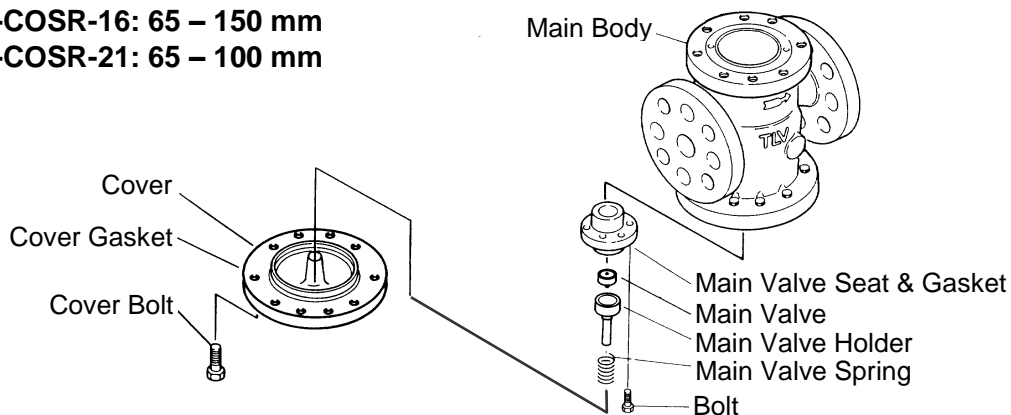

## Cleaning

After inspection and removal of any abnormality, clean and reassemble the parts.  
The following parts will require cleaning before reassembly:

Cover Plug / Cover	Piston Ring	Adjustment Screw
Main Valve Seat	Cylinder	Adjustment Screw Guide
Main Valve	Pilot Screen	
Main Valve Holder	Pilot Valve	
Piston	Pilot Valve Seat	

It is permissible to clean using water, however cleaning with a mild detergent is recommended for more effective cleaning.  
(Coat threaded position with anti-seize after cleaning.)

### <Actuator>

#### Disassembling the Actuator Section

By removing the hexagon bolts, the actuator section with adjustment screw can be detached from the spring housing. There is a thermal insulation plate between the flanges. Refrain from disassembling any further.

→Check to see if the adjustment screw rotates smoothly.

Check for seizing, chipping or similar defects on the threaded portion of the adjustment screw.

(If the actuator section is stuck and does not work, contact our sales representative.)

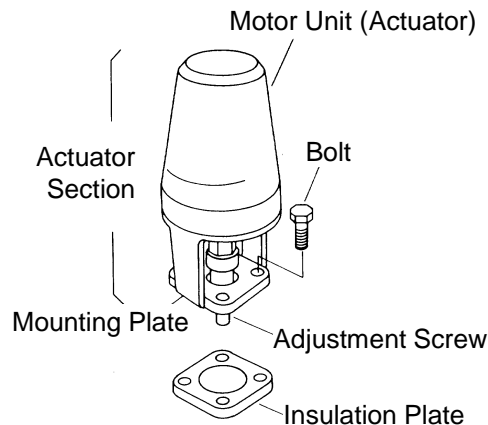

## Disassembling the Adjustment Section

Remove the bolts. By removing the spring housing, the diaphragm support, coil spring, ball and spring retainer are exposed.

→Check inside the spring retainer for dirt or other foreign material.

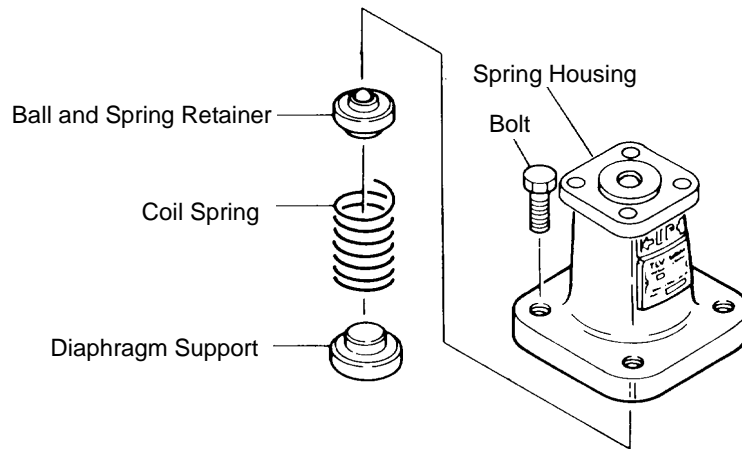

## <Controller>

### Replacing the Fuse

If the power ON LED fails to light even after the power switch is turned ON, check whether the fuse is blown.

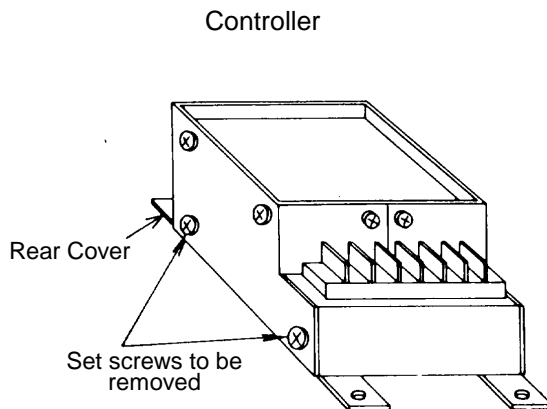

Figure 5.1

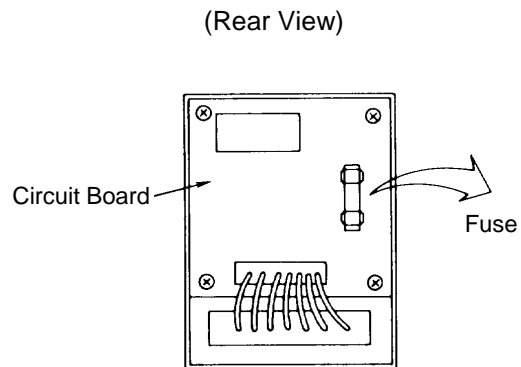

Figure 5.2

**CAUTION:** Be sure the main power is switched OFF before checking the fuse.

1. Remove both pair of set screws on the sides of the controller (Figure 5.1).
2. The cartridge fuse mounted inside is exposed by removing the rear cover (Figure 5.2).
3. Using a pair of electrician's pliers or similar implement, pry out the fuse and check. If blown, replace it with a new fuse.  
Fuse rating: 250V, 2A  
Type: Cartridge type, dia. 5.2 × 20 mm

## Inspecting and Adjusting the Pressure Indication

Equipment used for adjustment: DC current generator

1. An electric current of 4 mA DC is fed from the DC current generator to the pressure signal input terminals on the controller (terminal numbers: 8 (+ side) and 9 (- side)).
2. Check to see that the digital pressure indication then reads -002 to +002 ( $\pm 0.1\%FS$ ).
3. If the pressure reading indicated falls outside this range adjust with the zero adjustment screw shown in Fig. 5.3 until the pressure indicated comes into the range.

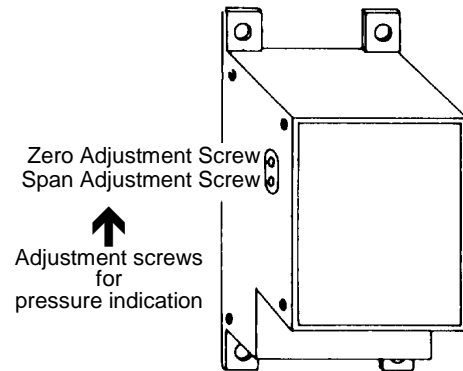

Figure 5.3

4. Next, change the input signal to 16 mA and check to see that the valve indicated reads 1498 – 1502 (374 to 376 for 500 kPa).
5. If the value indicated falls outside the range, adjust with the span (gain) adjustment screw shown in Fig. 5.3 until the correct reading is obtained.

NOTE: Except for the above-mentioned adjustments, the controller requires no further maintenance. If any abnormality is noted, contact our sales representatives.

### <Pressure Sensor (A standard TLV accessory)>

#### Inspection of Pressure Sensor

A periodic inspection should be carried out at least biannually.

1. Check for corrosion or clogging with dirt.  
Check for corrosion or clogging with dirt, etc., that may have occurred at the pressure inlet to the pressure sensor and the siphon pipe,

2. Inspection and adjustment of pressure outlet signal

Equipment used for adjustment: Reference pressure generator

Inspection and adjustment of the pressure sensor itself requires a power supply, multi-meter, etc, involving complicated procedures. Use a controller which has been properly adjusted as described in the previous paragraph "Inspecting and Adjusting Pressure Indication".

- (1) Check to see that the pressure reading indicates -010 to +010 (-003 to +003 for 500 kPa type) with no pressure applied (under atmospheric pressure).
- (2) Applying a randomly selected pressure (between 1500 to 1999 kPa approximately) from the reference pressure generator, check to see that the pressure reading indicates a value within  $\pm 10$  kPa ( $\pm 3$  kPa for 500 kPa type)
- (3) If the pressure reading deviates by more than 1%FS from the pressure applied, abnormality of the pressure sensor is possible. Contact our sales representative.

## Exploded View

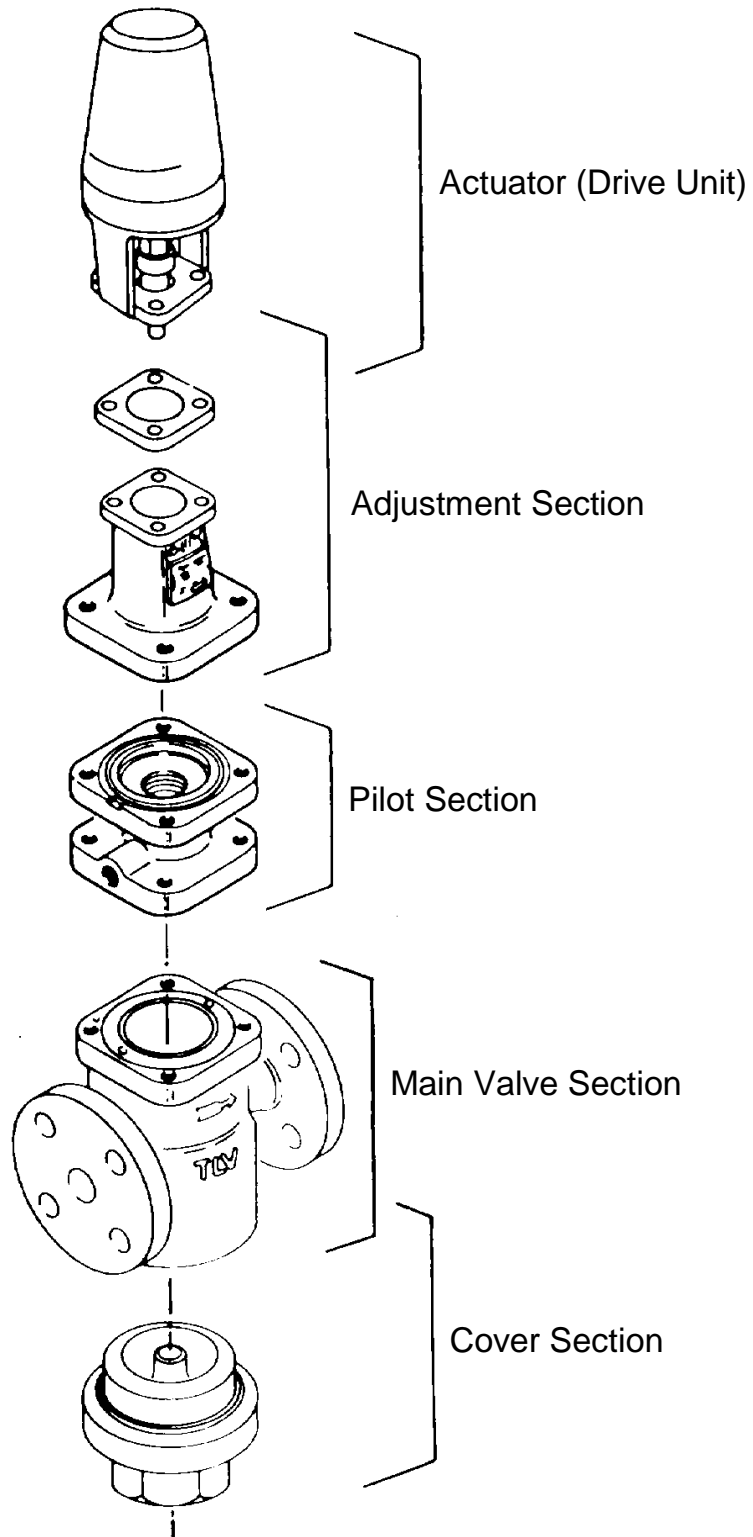

NOTE: Configuration for nominal size of 15 to 25 mm for M-COSR-3/16.  
Configurations for other sizes and models differ.

## Reassembly

Assemble the unit using the same procedure as used for disassembly; but in reverse order. Observe the following precautions:

1. The PTFE gaskets may be re-used if free from fault, crushing or deformation.
2. Apply anti-seize to the threaded portion of screws and bolts, the spring retainer, ball and adjustment screw. Apply a small amount of anti-seize to the threads of the main valve seat, pilot valve seat and pilot screen holder. Apply anti-seize carefully to ensure it does not come into contact with other parts.
3. Fasten the bolts one at a time in an alternating diagonal pattern to provide uniform seating.
4. After assembly, make sure that the piston and the pilot guide operate smoothly without binding.
  - 1) Fit the piston ring to the outside of the tension ring.
  - 2) The ring gaps should be opposite each other.
5. Standard fastening torque and the width across flats for the tools to be used are as follows:

Assembling the Piston Ring

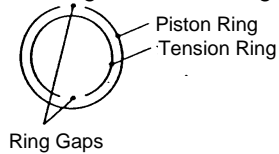

Part	M-COSR Connection Size (mm)	Width Across Flats (mm)	Tightening Torque (N·m)
Bolt for Mounting Plate/ Spring Housing	All	13	20
Bolts for Spring Housing / Pilot Body	All	17	40
Pilot Valve Seat	All	19	70
Pilot Screen Holder	All	24	40
Bolt for Pilot Body / Main Body	Sizes 15 – 40	17	60
	50	19	70
Bolt for Pilot Body / Pilot Cover	65 – 150	17	60
	65, 80	19	70
	100, 125	24	150
Main Valve Seat	150	36	300
	15, 20	36	100
	25	41	125
	32, 40	60	250
Bolts for Main Valve Seat	50	70	300
	65, 80	13	30
	100, 125	17	40
Cover Plug	150	22	70
	M-COSR-3/16: 15, 20	41	250
Cover Bolt	M-COSR-3/16: 25	46	350
	M-COSR-21: 15 – 25	17	60
	32, 40	17	60
	50 – 80	19	70
	100, 125	24	150
	150	36	300

(1 N·m ≈ 10 kg·cm)

NOTE: -If a torque greater than that recommended is applied, the body or components may be damaged.

-Coat all threaded portions with anti-seize.

-If drawings or other special documentation were supplied for the product, any torque given there takes precedence over values shown here.

## Troubleshooting



When disassembling or removing the product, wait until the internal pressure equals atmospheric pressure and the surface of the product has cooled to room temperature. Disassembling or removing the product when it is hot or under pressure may lead to discharge of fluids, causing burns, other injuries or damage.



Make sure the power supply switch is OFF before carrying out work on the wiring or inspections involving disassembly. If such work is carried out with the power on, there is a danger that equipment may malfunction or electric shock may occur, leading to injury or other accidents.



Make sure that wiring work requiring a special license is carried out by qualified personnel. If carried out by unqualified personnel, overheating or short circuits leading to injury, fires, damage or other accidents may occur.



When using this product, NEVER stand close to, or leave tools anywhere near moving parts, such as the shaft. Contact with moving parts or objects becoming caught in moving parts could lead to injury, damage or other accidents.

This product is shipped after stringent checks and inspection and should perform its intended function for a long period of time without failure. However, should there be any problem encountered in the operation of the M-COSR, consult the “Troubleshooting Chart” shown from the following page.

Problems are classified as follows:

1. The secondary pressure does not rise
2. The secondary pressure cannot be adjusted or increases abnormally
3. Hunting (fluctuation of the secondary pressure) occurs
4. Chattering (a heavy mechanical noise) occurs
5. Abnormal noises
6. Power supply LED does not light even after turning ON the power switch
7. Pressure indication is abnormal
8. Motor remains inoperative even after pressure setting switch is turned ON

Major causes for the above problems are usage under non-specified conditions (out of specification), insufficient pressure or flow rate, and clogs by dirt and scale.

To ensure performance for a long period of time, it is recommended that the “Acceptable Operating Range”, “Correct Usage of the M-COSR Motorized Pressure Reducing Valve” and “Controller Operation” sections be reviewed.

### Troubleshooting Chart

Problem	Symptom	Cause	Remedy
The secondary pressure does not rise	The body is not warm	No steam is being supplied or the inlet valve is closed	Check the valves and piping
	The body is warm, but the pressure does not increase	The entrance to the screens or strainer is clogged	Clean or blow down
The secondary pressure cannot be adjusted or increases abnormally	Motor is not turning over	Controller is malfunctioning	Check, repair
	Adjustment is difficult, and set pressure varies	The pilot screen is clogged	Clean
		There is insufficient steam flow	Check the flow, replace the M-COSR if necessary
		The piston is clogged with dirt	Clean Check the piston ring
		The piston ring is worn	Replace with a new piston ring
		The small hole on the piston is clogged	Clean
		There is a build-up of dirt on the sliding surfaces of the pilot valve, piston, or main valve	Clean
		Flow rate exceeds rated flow rate	Check the flow rate, replace with a larger size
		The adjustment screw has seized	Replace with a new adjustment screw
		The diaphragm is distorted or damaged	Replace with a new diaphragm
		There is fluctuation in steam consumption	Check the flow rate, replace the M-COSR if necessary
	The selected model is inappropriate for the service conditions (specifications)	Check the model selection, replace the M-COSR if necessary	
Upon closing the valves on the secondary side, the secondary pressure abruptly rises as high as the primary pressure	The bypass valve is leaking	Check, clean, and replace with a new valve if necessary	
	There is a build-up of dirt on or damage to the pilot valve seat or main valve seat	Clean Align Replace if necessary	
Hunting or chattering occurs	Occurs at low steam demand	It is being operated below the lower flow rate limit	Check the volume of steam supply, replace with a smaller diameter valve
	Hunting never stops	There is too high a reduction ratio (operated at below 10% of the primary pressure)	Use a two-stage reduction arrangement
		The selected model is inappropriate for the service conditions (specifications)	Check the model selection, replace the M-COSR if necessary

Continued on the next page



<b>Problem</b>	<b>Symptom</b>	<b>Cause</b>	<b>Remedy</b>
Hunting or chattering occurs (continued)	Chattering never stops	Entrained condensate	Check the piping
		The selected model is inappropriate for the service conditions (specifications)	Check the model selection, replace the M-COSR if necessary
Abnormal noises	Makes a high-pitched noise	There is too high a reduction ratio, the flow is too great, or there is a high-speed open / close valve nearby	Use two-stage reduction Check the flow rate, use a larger size valve Install the valve as far away as possible
Power supply LED does not light even after turning ON the power switch		Wiring is arranged incorrectly	Rearrange wiring
		Fuse is burnt-out	Replace fuse
Pressure indication is abnormal		Faulty connection with pressure sensor, or break in the wiring	Rearrange wiring
	Pressure indication is abnormal	Adjustment for controller and pressure sensor are not made properly	Readjust zero/span (gain)
Motor remains inoperative even after pressure setting switch is turned ON		The pressure lock switch is turned ON	Turn OFF the pressure lock switch
		Maximum allowable pressure switch is ON	Release the maximum allowable pressure switch
		Wiring to actuator is incorrect	Rearrange wiring

## TLV EXPRESS LIMITED WARRANTY

Subject to the limitations set forth below, TLV CO., LTD., a Japanese corporation (“**TLV**”), warrants that products which are sold by it, TLV International Inc. (“**TII**”) or one of its group companies excluding TLV Corporation (a corporation of the United States of America), (hereinafter the “**Products**”) are designed and manufactured by TLV, conform to the specifications published by TLV for the corresponding part numbers (the “**Specifications**”) and are free from defective workmanship and materials. The party from whom the Products were purchased shall be known hereinafter as the “**Seller**”. With regard to products or components manufactured by unrelated third parties (the “**Components**”), TLV provides no warranty other than the warranty from the third party manufacturer(s), if any.

### Exceptions to Warranty

This warranty does not cover defects or failures caused by:

1. improper shipping, installation, use, handling, etc., by persons other than TLV, TII or TLV group company personnel, or service representatives authorized by TLV; or
2. dirt, scale or rust, etc.; or
3. improper disassembly and reassembly, or inadequate inspection and maintenance by persons other than TLV or TLV group company personnel, or service representatives authorized by TLV; or
4. disasters or forces of nature or Acts of God; or
5. abuse, abnormal use, accidents or any other cause beyond the control of TLV, TII or TLV group companies; or
6. improper storage, maintenance or repair; or
7. operation of the Products not in accordance with instructions issued with the Products or with accepted industry practices; or
8. use for a purpose or in a manner for which the Products were not intended; or
9. use of the Products in a manner inconsistent with the Specifications; or
10. use of the Products with Hazardous Fluids (fluids other than steam, air, water, nitrogen, carbon dioxide and inert gases (helium, neon, argon, krypton, xenon and radon)); or
11. failure to follow the instructions contained in the TLV Instruction Manual for the Product.

### Duration of Warranty

This warranty is effective for a period of one (1) year after delivery of Products to the first end user. Notwithstanding the foregoing, asserting a claim under this warranty must be brought within three (3) years after the date of delivery to the initial buyer if not sold initially to the first end user.

ANY IMPLIED WARRANTIES NOT NEGATED HEREBY WHICH MAY ARISE BY OPERATION OF LAW, INCLUDING THE IMPLIED WARRANTIES OF MERCHANTABILITY AND FITNESS FOR A PARTICULAR PURPOSE AND ANY EXPRESS WARRANTIES NOT NEGATED HEREBY, ARE GIVEN SOLELY TO THE INITIAL BUYER AND ARE LIMITED IN DURATION TO ONE (1) YEAR FROM THE DATE OF SHIPMENT BY THE SELLER.

### Exclusive Remedy

THE EXCLUSIVE REMEDY UNDER THIS WARRANTY, UNDER ANY EXPRESS WARRANTY OR UNDER ANY IMPLIED WARRANTIES NOT NEGATED HEREBY (INCLUDING THE IMPLIED WARRANTIES OF MERCHANTABILITY AND FITNESS FOR A PARTICULAR PURPOSE), IS **REPLACEMENT**; PROVIDED: (a) THE CLAIMED DEFECT IS REPORTED TO THE SELLER IN WRITING WITHIN THE WARRANTY PERIOD, INCLUDING A DETAILED WRITTEN DESCRIPTION OF THE CLAIMED DEFECT AND HOW AND WHEN

THE CLAIMED DEFECTIVE PRODUCT WAS USED; AND (b) THE CLAIMED DEFECTIVE PRODUCT AND A COPY OF THE PURCHASE INVOICE IS RETURNED TO THE SELLER, FREIGHT AND TRANSPORTATION COSTS PREPAID, UNDER A RETURN MATERIAL AUTHORIZATION AND TRACKING NUMBER ISSUED BY THE SELLER. ALL LABOR COSTS, SHIPPING COSTS, AND TRANSPORTATION COSTS ASSOCIATED WITH THE RETURN OR REPLACEMENT OF THE CLAIMED DEFECTIVE PRODUCT ARE SOLELY THE RESPONSIBILITY OF BUYER OR THE FIRST END USER. THE SELLER RESERVES THE RIGHT TO INSPECT ON THE FIRST END USER'S SITE ANY PRODUCTS CLAIMED TO BE DEFECTIVE BEFORE ISSUING A RETURN MATERIAL AUTHORIZATION. SHOULD SUCH INSPECTION REVEAL, IN THE SELLER'S REASONABLE DISCRETION, THAT THE CLAIMED DEFECT IS NOT COVERED BY THIS WARRANTY, THE PARTY ASSERTING THIS WARRANTY SHALL PAY THE SELLER FOR THE TIME AND EXPENSES RELATED TO SUCH ON-SITE INSPECTION.

#### **Exclusion of Consequential and Incidental Damages**

IT IS SPECIFICALLY ACKNOWLEDGED THAT THIS WARRANTY, ANY OTHER EXPRESS WARRANTY NOT NEGATED HEREBY, AND ANY IMPLIED WARRANTY NOT NEGATED HEREBY, INCLUDING THE IMPLIED WARRANTIES OF MERCHANTABILITY AND FITNESS FOR A PARTICULAR PURPOSE, DO NOT COVER, AND NEITHER TLV, TII NOR ITS TLV GROUP COMPANIES WILL IN ANY EVENT BE LIABLE FOR, INCIDENTAL OR CONSEQUENTIAL DAMAGES, INCLUDING, BUT NOT LIMITED TO LOST PROFITS, THE COST OF DISASSEMBLY AND SHIPMENT OF THE DEFECTIVE PRODUCT, INJURY TO OTHER PROPERTY, DAMAGE TO BUYER'S OR THE FIRST END USER'S PRODUCT, DAMAGE TO BUYER'S OR THE FIRST END USER'S PROCESSES, LOSS OF USE, OR OTHER COMMERCIAL LOSSES. WHERE, DUE TO OPERATION OF LAW, CONSEQUENTIAL AND INCIDENTAL DAMAGES UNDER THIS WARRANTY, UNDER ANY OTHER EXPRESS WARRANTY NOT NEGATED HEREBY OR UNDER ANY IMPLIED WARRANTY NOT NEGATED HEREBY (INCLUDING THE IMPLIED WARRANTIES OF MERCHANTABILITY AND FITNESS FOR A PARTICULAR PURPOSE) CANNOT BE EXCLUDED, SUCH DAMAGES ARE EXPRESSLY LIMITED IN AMOUNT TO THE PURCHASE PRICE OF THE DEFECTIVE PRODUCT. THIS EXCLUSION OF CONSEQUENTIAL AND INCIDENTAL DAMAGES, AND THE PROVISION OF THIS WARRANTY LIMITING REMEDIES HEREUNDER TO REPLACEMENT, ARE INDEPENDENT PROVISIONS, AND ANY DETERMINATION THAT THE LIMITATION OF REMEDIES FAILS OF ITS ESSENTIAL PURPOSE OR ANY OTHER DETERMINATION THAT EITHER OF THE ABOVE REMEDIES IS UNENFORCEABLE, SHALL NOT BE CONSTRUED TO MAKE THE OTHER PROVISIONS UNENFORCEABLE.

#### **Exclusion of Other Warranties**

THIS WARRANTY IS IN LIEU OF ALL OTHER WARRANTIES, EXPRESS OR IMPLIED, AND ALL OTHER WARRANTIES, INCLUDING BUT NOT LIMITED TO THE IMPLIED WARRANTIES OF MERCHANTABILITY AND FITNESS FOR A PARTICULAR PURPOSE, ARE EXPRESSLY DISCLAIMED.

#### **Severability**

Any provision of this warranty which is invalid, prohibited or unenforceable in any jurisdiction shall, as to such jurisdiction, be ineffective to the extent of such invalidity, prohibition or unenforceability without invalidating the remaining provisions hereof, and any such invalidity, prohibition or unenforceability in any such jurisdiction shall not invalidate or render unenforceable such provision in any other jurisdiction.

## Service

For Service or Technical Assistance: Contact your TLV representative or your regional TLV office.

### In Europe:

#### **TLV EURO ENGINEERING GmbH**

Daimler-Benz-Straße 16-18, 74915 Waibstadt, **Germany**

Tel: [49]-(0)7263-9150-0  
Fax: [49]-(0)7263-9150-50

#### **TLV EURO ENGINEERING UK LTD.**

Units 7 & 8, Furlong Business Park, Bishops Cleeve, Gloucestershire GL52 8TW, **U.K.**

Tel: [44]-(0)1242-227223  
Fax: [44]-(0)1242-223077

#### **TLV EURO ENGINEERING FRANCE SARL**

Parc d'Ariane 2, bât. C, 290 rue Ferdinand Perrier, 69800 Saint Priest, **France**

Tel: [33]-(0)4-72482222  
Fax: [33]-(0)4-72482220

### In North America:

#### **TLV CORPORATION**

13901 South Lakes Drive, Charlotte, NC 28273-6790, **U.S.A.**

Tel: [1]-704-597-9070  
Fax: [1]-704-583-1610

### In Mexico and Latin America:

#### **TLV ENGINEERING S. A. DE C.V.**

Av. Jesús del Monte 39-B-1001, Col. Hda. de las Palmas, Huixquilucan, Edo. de México, 52763, **Mexico**

Tel: [52]-55-5359-7949  
Fax: [52]-55-5359-7585

### In Oceania:

#### **TLV PTY LIMITED**

Unit 8, 137-145 Rooks Road, Nunawading, Victoria 3131, **Australia**

Tel: [61]-(0)3-9873 5610  
Fax: [61]-(0)3-9873 5010

### In East Asia:

#### **TLV PTE LTD**

36 Kaki Bukit Place, #02-01/02, **Singapore** 416214

Tel: [65]-6747 4600  
Fax: [65]-6742 0345

#### **TLV SHANGHAI CO., LTD.**

Room 5406, No. 103 Cao Bao Road, Shanghai, **China** 200233

Tel: [86]-(0)21-6482-8622  
Fax: [86]-(0)21-6482-8623

#### **TLV ENGINEERING SDN. BHD.**

No.16, Jalan MJ14, Taman Industri Meranti Jaya, 47120 Puchong, Selangor, **Malaysia**

Tel: [60]-3-8065-2928  
Fax: [60]-3-8065-2923

#### **TLV PRIVATE LIMITED**

252/94 (K-L) 17th Floor, Muang Thai-Phatra Complex Tower B, Rachadaphisek Road, Huaykwang, Bangkok 10310, **Thailand**

Tel: [66]-2-693-3799  
Fax: [66]-2-693-3979

#### **TLV INC.**

#302-1 Bundang Technopark B, 723 Pangyo-ro, Bundang, Seongnam, Gyeonggi, 13511, **Korea**

Tel: [82]-(0)31-726-2105  
Fax: [82]-(0)31-726-2195

### In the Middle East:

#### **TLV ENGINEERING FZCO**

Building 2W, No. M002, PO Box 371684, Dubai Airport Free Zone, Dubai, **UAE**

Email: sales-me@tlv.co.jp

### In Other Countries:

#### **TLV INTERNATIONAL, INC.**

881 Nagasuna, Noguchi, Kakogawa, Hyogo 675-8511, **Japan**

Tel: [81]-(0)79-427-1818  
Fax: [81]-(0)79-425-1167

### Manufacturer:

#### **TLV CO., LTD.**

881 Nagasuna, Noguchi, Kakogawa, Hyogo 675-8511, **Japan**

Tel: [81]-(0)79-422-1122  
Fax: [81]-(0)79-422-0112