

ISO 9001  
ISO14001



Manufacturer

**TLV** CO., LTD.

Kakogawa, Japan

is approved by LRQA Ltd. to ISO 9001:2001



# Instruction Manual

---

**Steam Condensing Heat Exchanger**

Featured Models: SR-3/SR-8

172-65207M-09

Publication date 31 January 2024

Copyright © 2024 TLV CO., LTD

# Table of Contents

- Introduction ..... 3
- Safety Considerations ..... 4
- Intended Use ..... 6
- System Principle ..... 7
- Specifications ..... 8
- Configuration ..... 9
- Installation ..... 10
- Operation ..... 18
- Inspection and Maintenance ..... 20
- Troubleshooting ..... 21
- TLV EXPRESS LIMITED WARRANTY ..... 22
- Service ..... 24

# Introduction

Thank you for purchasing the TLV SR steam condensing heat exchanger.

This product has been thoroughly inspected before being shipped from the factory. When the product is delivered, before doing anything else, check the specifications and external appearance to make sure nothing is out of the ordinary. Also be sure to read this manual carefully before use and follow the instructions to be sure of using the product properly.

If detailed instructions for special order specifications or options not contained in this manual are required, please contact TLV for full details.

This instruction manual is intended for use with the model(s) listed on the front cover. It is necessary not only for installation but for subsequent maintenance and troubleshooting. Please keep it in a safe place for future reference.

# Safety Considerations

- Read this section carefully before use and be sure to follow the instructions.
- Installation, inspection, maintenance, repairs, disassembly, adjustment and valve opening/closing should be carried out only by trained maintenance personnel.
- The precautions listed in this manual are designed to ensure safety and prevent equipment damage and personal injury. For situations that may occur as a result of erroneous handling, three different types of cautionary items are used to indicate the degree of urgency and the scale of potential damage and danger: DANGER, WARNING and CAUTION.
- The three types of cautionary items above are very important for safety: be sure to observe all of them as they relate to installation, use, maintenance and repair. Furthermore, TLV accepts no responsibility for any accidents or damage occurring as a result of failure to observe these precautions.

## Cautionary items and definitions



### Danger

Indicates an urgent situation which poses a threat of death or serious injury



### Warning

Indicates that there is a potential threat of death or serious injury



### Caution

Indicates that there is a possibility of injury or equipment/product damage

## Safety Considerations for the Product



### Caution

**Install properly and DO NOT use this product outside the recommended operating pressure, temperature and other specification ranges.** Improper use may result in such hazards as damage to the product or malfunctions that may lead to serious accidents. Local regulations may restrict the use of this product to below the conditions quoted.



### Caution

**Use hoisting equipment for heavy objects (weighing approximately 20 kg (44 lb) or more).** Failure to do so may result in back strain or other injury if the object should fall.



### Caution

**Take measures to prevent people from coming into direct contact with product outlets.** Failure to do so may result in burns or other injury from the discharge of fluids.



### Caution

**When disassembling or removing accessories used with the product, wait until the internal pressure equals atmospheric pressure and the surface of the product has cooled to room temperature.** Disassembling or removing accessories from the product when it is hot or under pressure may lead to discharge of fluids, causing burns, other injuries or damage.



### Caution

**Be sure to use only the recommended components when repairing the product, and NEVER attempt to modify the product in any way.** Failure to observe these precautions may result in damage to the product and burns or other injury due to malfunction or the discharge of fluids.

**Caution**

**Do not use excessive force when connecting threaded pipes to the product.** Over-tightening may cause breakage leading to fluid discharge, which may cause burns or other injury.

**Caution**

**In case of unexpected steam flow, connect piping from the exhaust outlet to a safe area.** Unexpectedly high steam volumes may cause high-temperature condensate to be discharged through the exhaust outlet, which may in turn cause burns or other injury.

**Caution**

**Operate valves slowly and carefully.** Opening or closing valves too quickly may cause water hammer to occur, the impact of which could cause damage to equipment.

**Caution**

**Use only under conditions in which no freeze-up will occur.** Freezing may damage the product, leading to fluid discharge, which may cause burns or other injury. If the water seal or inside of the tube freeze, the inside of the product may be pressurized which could cause problems on equipment or devices that are connected to the product.

# Intended Use

This product is an atmospheric indirect heat exchanger for recovering heat energy from waste or flash steam for applications where the steam cannot otherwise be utilized.

By using this product for waste heat recovery or steam condensation, system energy efficiency, work environment, and plant scenery can be improved without increasing back pressure on steam-using equipment.

## Usages

- Flash steam from applications such as steamers, sterilizers and vulcanizers where the steam cannot otherwise be utilized and released to the atmosphere
- Flash steam escaping from hot water/processing tanks
- Flash steam escaping from condensate tanks into the atmosphere



### Note

Limited to applications in which steam incorporates no air or non-condensable gases.

## Improvement effect

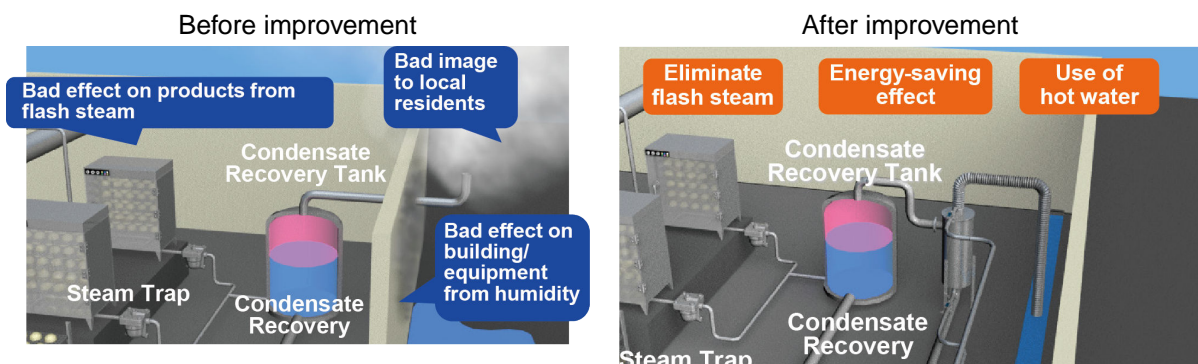

- Lower system steam usage by collecting unusable 100 °C (212 °F) steam and employing it in processes such as water heating which previously used main line steam
- Improves work environment and plant scenery by eliminating clouds of steam generated around the plant
- Because waste steam processing can be carried out indoors, it is not necessary to construct outdoor duct piping; further reducing costs

# System Principle

Because the product does not have any valve parts on the Waste Steam Recovery side, it does not create any back-pressure on upstream equipment. For this reason, it can be directly connected to and used with feed water tanks and other vessels that do not meet pressure vessel regulations in most locations. Consult TLV for details.

Concerning the construction of the unit, there is a condensate outlet in the base of the heat exchanger. This allows a water seal to be maintained which directly prevents steam leakage. Thus, with a similar construction to closed type heat exchangers, it can ensure an equivalent level of high efficiency heat exchange.

## Operation Flow

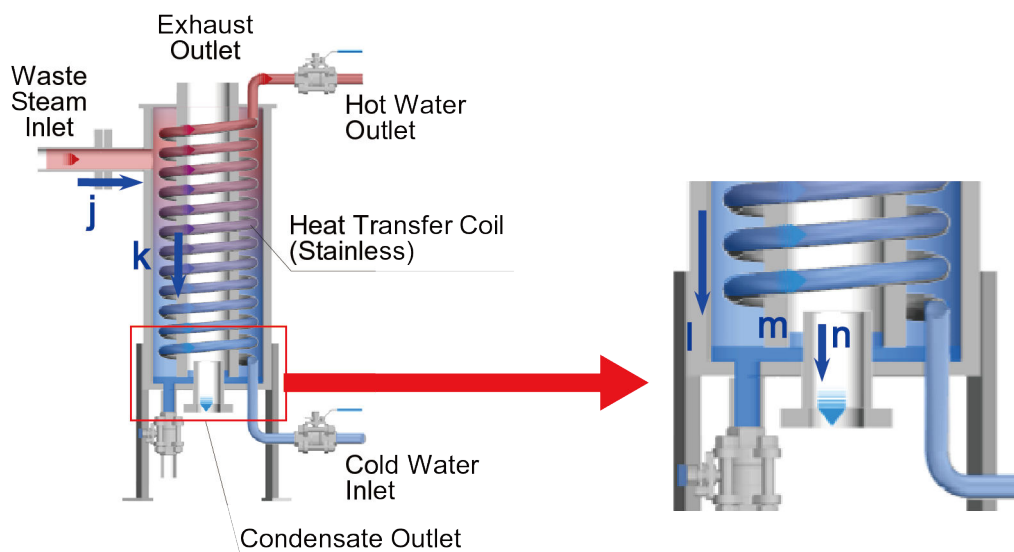

1. Waste steam flows into the SR from equipment connected to the steam inlet.
2. Waste steam which has flowed into the SR (shell side) transfers heat to cold water inside the heat transfer coil.
3. Upon transferring heat the waste steam condenses and drips down to collect in the base of the SR.  
Furthermore, since condensing steam inside an airtight space produces a fall in pressure, the inside of the SR is maintained at atmospheric pressure or a very slight vacuum (0.5 kPaG (0.07 psig)) which ensures a smooth influx of waste steam.
4. Condensate accumulated in the base of the tank seals the outlet, and it becomes similar in structure to a pseudo closed type heat exchanger.
5. Furthermore, after waste steam transfers heat away and becomes condensate, it overflows and is discharged to the outside.
6. If the cold water flow rate decreases, or else the ability of the cold water to absorb heat is surpassed causing an influx of waste steam; even if waste steam accumulates inside the SR and the pressure begins to rise; the instant that the pressure rises above 0.5 kPaG (0.07 psig) (a water seal with 50 mm (2 in) of head pressure) the water seal will be broken and waste steam will be discharged to the atmosphere through the exhaust outlet. (Pressure will not accumulate inside the unit.)

# Specifications



**Caution**  
**Install properly and DO NOT use this product outside the recommended operating pressure, temperature and other specification ranges.** Improper use may result in such hazards as damage to the product or malfunctions that may lead to serious accidents. Local regulations may restrict the use of this product to below the conditions quoted.

**Use only under conditions in which no freeze-up will occur.** Freezing may damage the product, leading to fluid discharge, which may cause burns or other injury. If the water seal or inside of the tube freeze, the inside of the product may be pressurized which could cause problems on equipment or devices that are connected to the product.

Refer to the product nameplate for detailed specifications. Do not install valves or orifices at the exhaust outlet, since this product is an atmospheric type heat exchanger.

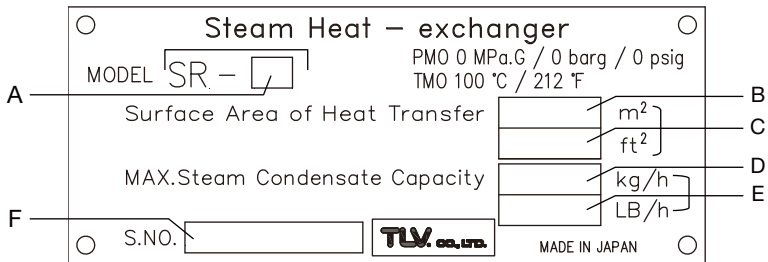

A	Model	D	Heat Transfer Surface Area
B	Maximum Opoerating Pressure (PMO)	E	Maximu Steam Flow Rate
C	Maximum Operating Temperature (TMO)	F	Serial No.



# Configuration

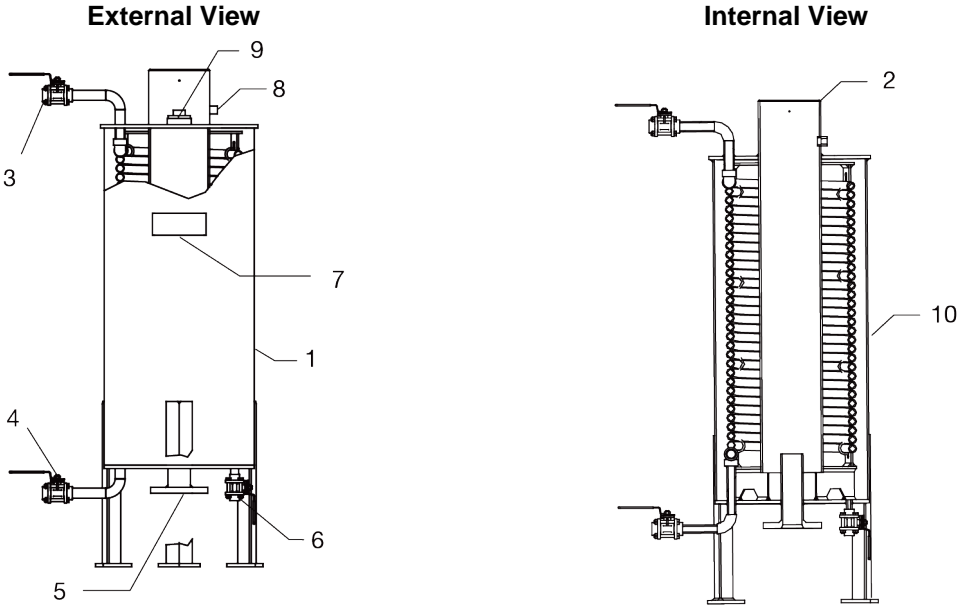

**Note**

- The figure above shows the SR-3. The internal configuration of the SR-8 differs slightly from SR-3.
- Depending on the specifications, the product may or may not feature an overflow outlet for the exhaust pipe.

No.	Description	No.	Description
1	Body	6	Condensate Blow Outlet
2	Exhaust Outlet (Duct Nipple installable)	7	Nameplate
3	Hot Water Outlet	8	Overflow Outlet for Exhaust Pipe
4	Cold Water Inlet	9	Plug for maintenance
5	Condensate Outlet	10	Heat Transfer Coil

# Installation



## Caution

**Install properly and DO NOT use this product outside the recommended operating pressure, temperature and other specification ranges.** Improper use may result in such hazards as damage to the product or malfunctions that may lead to serious accidents. Local regulations may restrict the use of this product to below the conditions quoted.

**In case of unexpected steam flow, connect piping from the exhaust outlet to a safe area.** Unexpectedly high steam volumes may cause high-temperature condensate to be discharged through the exhaust outlet, which may in turn cause burns or other injury.

**Take measures to prevent people from coming into direct contact with product outlets.** Failure to do so may result in burns or other injury from the discharge of fluids.

**Do not use excessive force when connecting threaded pipes to the product.** Over-tightening may cause breakage leading to fluid discharge, which may cause burns or other injury.

## Precautions before Installation

Installation, inspection, maintenance, repairs, disassembly, adjustment and valve opening/closing should be carried out only by trained maintenance personnel.

For the specific installation location of the product, carefully consult the user. Confirm following items for the installation.

1. Before installing the product, carefully discuss and ensure the installation and piping method.
2. Do not install the product near a stairway or emergency exit.
3. The surface for installation of the product should be sturdy and horizontal.  
As the SR is heavy equipment, anchor the legs securely on a strong and horizontal foundation using the anchor bolts. (Dimension of anchor bolts: M16)  
Refer to the illustration on the next page regarding the position for anchor bolts and number of anchor bolts required.
4. For cases where people or products may come in contact with the SR unit, any safety measures, such as insulation or isolation, should be implemented to prevent injury. Even if such contact is unlikely, it is recommended that the product be as well insulated as possible to increase heat efficiency.
5. Maintenance space should be secured. Although the product cannot be disassembled, maintenance space should be secured for valves, etc.  
Refer to the illustration on the next page regarding maintenance space.
6. If the product is installed at height, make sure to install the product such that there is enough space to carry out maintenance work etc. with anti-drop measures such as handrails having been implemented. We may not be able to perform technical support service in a location where work cannot be safely carried out.

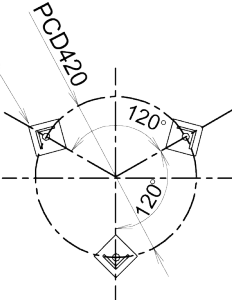
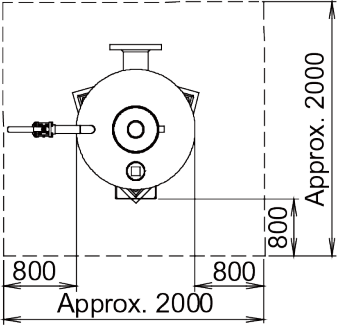
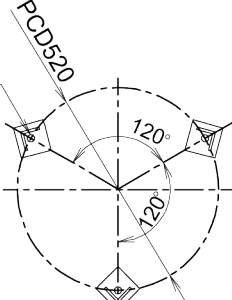
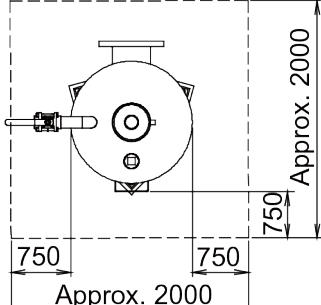
Model	Position for Anchor Bolts	Maintenance Space (Unit: mm (in))
SR-3	<p data-bbox="464 241 651 271">3 – <math>\phi 19</math> bolt hole</p>  <p data-bbox="564 510 783 539">Anchor bolts: M16</p> <p data-bbox="469 544 879 573">Total length: 80 mm (<math>3\frac{1}{8}</math> in) 3 pcs.</p>	 <p data-bbox="1050 501 1214 530">Approx. 2000</p> <p data-bbox="1299 264 1326 427">Approx. 2000</p> <p data-bbox="1007 472 1038 501">800</p> <p data-bbox="1262 421 1289 472">800</p>
SR-8	<p data-bbox="464 645 651 674">3 – <math>\phi 19</math> bolt hole</p>  <p data-bbox="564 913 783 943">Anchor bolts: M16</p> <p data-bbox="469 947 879 976">Total length: 220 mm (<math>8\frac{5}{8}</math> in) 3 pcs.</p>	 <p data-bbox="1058 880 1222 909">Approx. 2000</p> <p data-bbox="1289 622 1316 786">Approx. 2000</p> <p data-bbox="1015 842 1046 871">750</p> <p data-bbox="1198 790 1225 842">750</p>



**Note**

Anchor bolts are selected with standard seismic intensity: 1, and horizontal seismic coefficient: 1.

# Installation Example for Piping to/from the Product

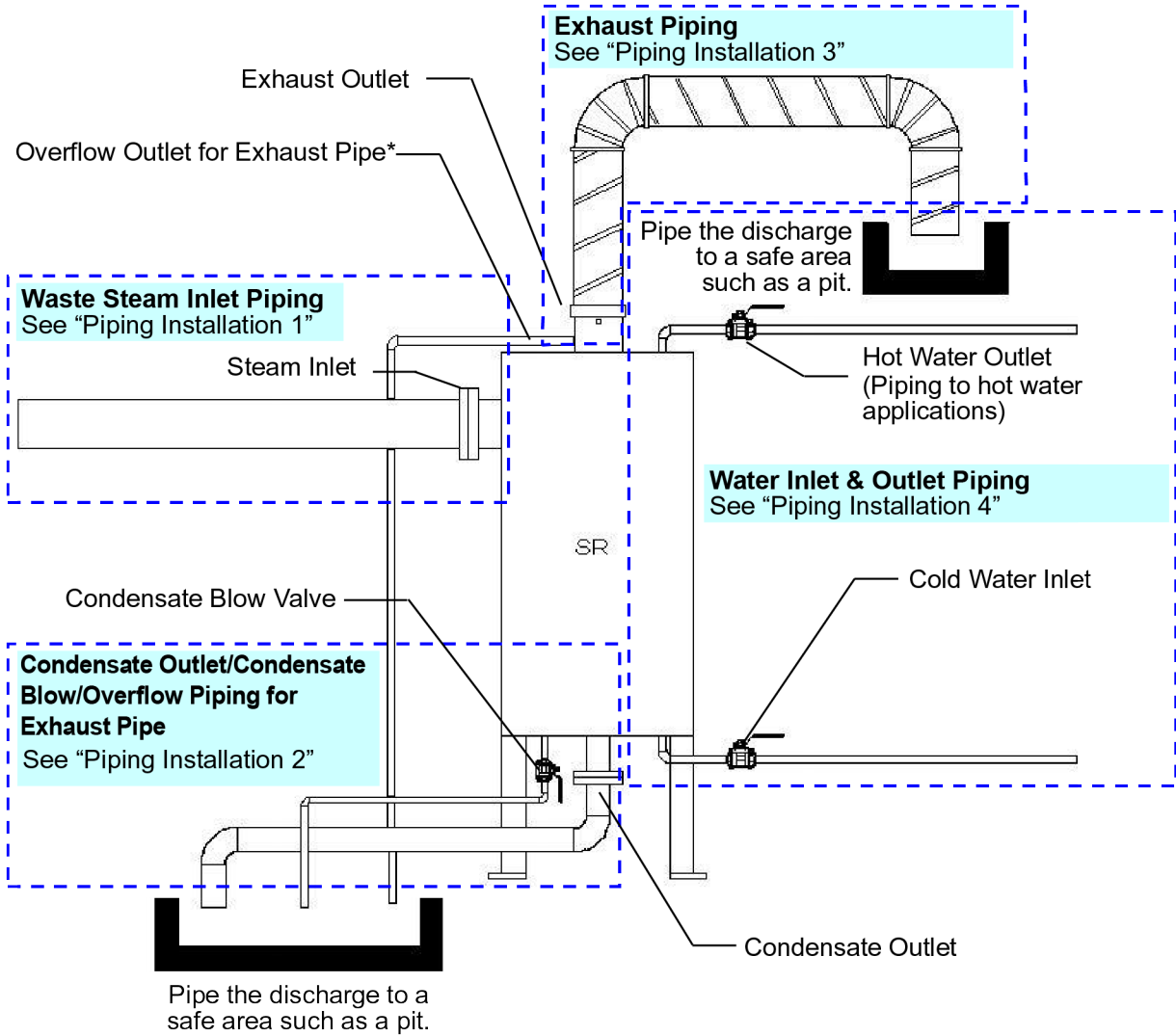

Please carefully refer to the "Piping Installation" section described on the following pages for important points regarding piping arrangements.

**Note**  
 Depending on the specifications, the product may or may not feature an overflow outlet for the exhaust pipe.

## Piping Installation 1: Waste Steam Inlet Piping

Make sure that the steam piping to the SR is installed with **no condensate accumulation points (places where piping rises or falls)**.

(This may cause water hammer or an increase in back pressure due to the water seal.)

If condensate accumulates because of the piping shape, install a steam trap at the point that condensate accumulates. Do not allow a rise in the piping at the trap outlet and direct the outlet to the atmosphere.

(To allow head pressure to discharge condensate in the absence of differential pressure, construct piping length according to the illustration below.)

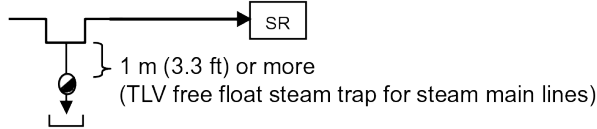

If the steam recovery source is a **feed water tank or other “non pressure vessel”**, do not install **valves, check valves, etc. on the steam piping**.

(Influenced by pressure vessel regulation.)

(This does not apply if the steam recovery source is a pressure vessel.)

Steam Inlet

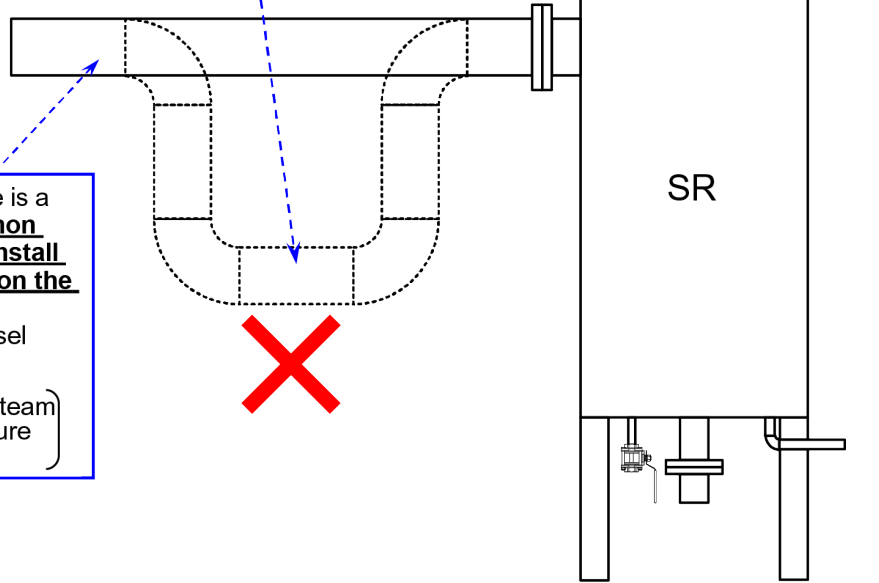

### Other cautions

The piping diameter should be sized so that the flow velocity of steam is approximately 20 m/sec (66 ft/sec).

To handle steam without applying back pressure on steam-using equipment, it is recommended that the piping be of the same diameter as the SR steam inlet (SR-3: 80 mm (3 in), SR-8: 150 mm (6 in)). Suggested diameters for the steam inlet piping are as follows:

Steam Flow kg/h (lb/h)	50 (110)	100 (220)	150 (330)	200 (440)	300 (660)	400 (880)	500 (1100)	600 (1320)	800 (1760)
Pipe Diameter mm (in)	40 (1½)	50 (2)	50 (2)	80 (3)	80 (3)	100 (4)	100 (4)	125 (5)	150 (6)

## Piping Installation 2: Condensate Outlet Piping, Blowdown Piping and Overflow Piping for Exhaust Pipe

Make sure that the condensate outlet piping from the equipment is installed **without any rise** in the piping as the back pressure could interfere with the normal operation of the SR.

Install separate condensate outlet piping, condensate blowdown piping and overflow piping for exhaust pipe leading to a safe area such as a pit.

If the piping to the pit is long, operation will not be affected even if the **blowdown piping is connected to the condensate outlet piping**. However, there are risks such as **forgetting to close the valve, delays in discovering failures, the accumulated scale in the SR flowing into the condensate outlet piping** at the time of condensate blowdown, etc.

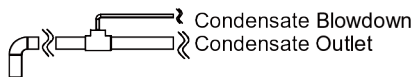

**Install piping from the condensate outlet to a safe area such as a pit where people will not come into contact** with discharged condensate or flash steam. Discharge of condensate or flash steam may cause burns or other injury.

Pipe the discharge to a safe area such as a pit.

Make sure that the condensate blowdown piping from the equipment is installed **without any rise** in the piping as it could interfere with the condensate blowdown.

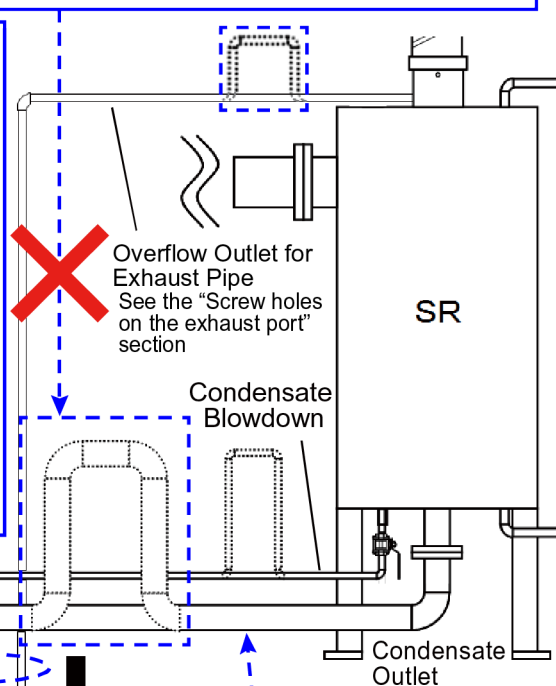

### Other cautions

When back pressure is applied to the SR, it also affects the upstream equipment from which waste steam is recovered. Even though piping with the same diameter as the condensate outlet piping of the SR is recommended to prevent back pressure from being applied to the SR, it is possible to use a smaller pipe diameter depending on the length of the pipe to the pit or discharge destination.

Suggested diameters for the condensate outlet piping are as follows:

When the condensate outlet valve or the overflow piping for exhaust pipe is installed, make sure to use either a full-bore ball valve or a gate valve so that back pressure does not interfere with the operation of the SR.

Pipe Length to Pit or Recovery Destination	Less than 10 m (33 ft)	10 m to 50 m (33 ft to 164 ft)	Greater than 50 m (164 ft)
Output Pipe Diameter	25 mm (1 in)	40 mm (1½ in)	50 mm (2 in)



#### Note

Depending on the specifications, the product may or may not feature an overflow outlet for exhaust pipe. Products without an overflow outlet should be fitted with an overflow line of nominal diameter 10 mm (3/8 in) or more.

## Piping Installation 3: Exhaust Piping

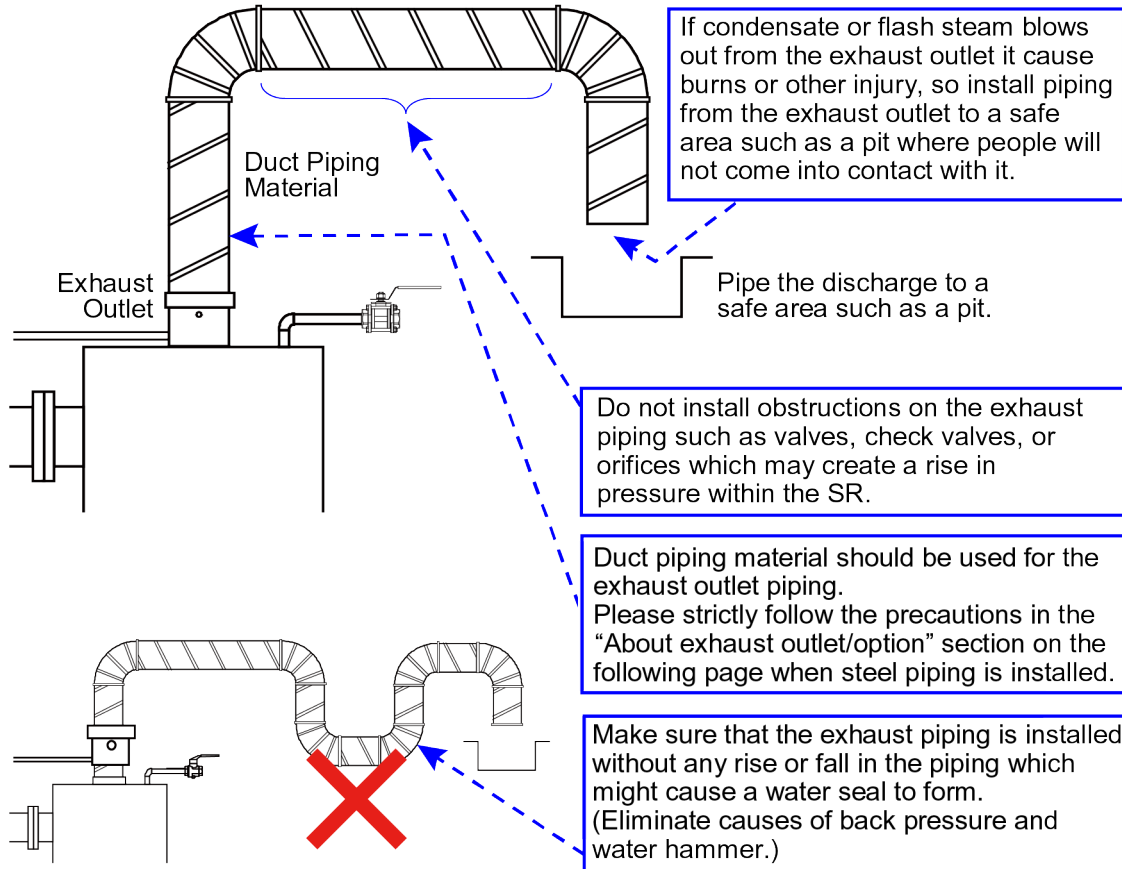

### Other cautions

Be certain to connect exhaust piping to protect against instances of unexpectedly high-volume waste steam flow into the SR, which may cause waste steam/hot water to be discharged. When back pressure is applied to the SR, it also affects the upstream equipment from which waste steam is recovered.

To prevent putting back-pressure on upstream equipment, make exhaust piping as large in diameter, short, and with as few bends as possible. Even though piping with the same diameter as the exhaust piping of the SR is recommended to prevent putting back pressure on the SR, it is possible to use a smaller pipe diameter depending on the length of the pipe to the pit or recovery destination.

Suggested diameters for the exhaust piping are as follows:

Length & Diameter of Exhaust Piping	SR-3	SR-8
Less than 10 m (33 ft)	50 mm (2 in)	80 mm (3 in)
10 m to 20 m (33 ft to 66 ft)	80 mm (3 in)	100 mm (4 in)
20 m to 30 m (66 ft to 98 ft)	100 mm (4 in)	150 mm (6 in)
Greater than 30 m (98 ft)	150 mm (6 in)	150 mm (6 in)

### Connecting the duct piping to the exhaust outlet

The standard connection specification of the exhaust outlet for the product is "duct piping installable". Nipple fittings should be used to connect the product and the piping, making sure that there is no leakage.

### Piping example

1. All duct piping should withstand high temperatures of 100 °C (212 °F). Coat the nipple with duct sealant.
2. Insert the nipple into the product, then the duct piping into the nipple. After everything is set in place, fix with screws (screw holes on the product: M5 × 2 locations).
3. After fixing with screws, wrap with two or three layers of tape that can withstand the required heat.

### About exhaust outlet/options

The exhaust outlet of the product can be produced with a flange connection as an option. However, specification changes after delivery cannot be accepted.

The exhaust piping should be supported firmly, making sure to avoid excessive force on the product. (Excessive force may lead to damage to the product.)

<Flange shape diagram>  
 SR-3/SR-8  
 Nominal diameter: 150 mm (6 in)

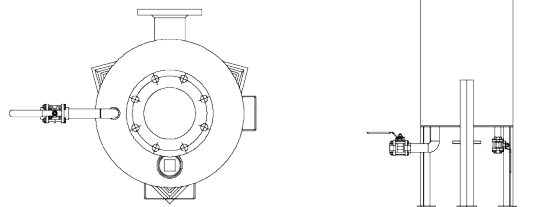

### In cases where the piping is welded directly to the exhaust outlet

C3 chamfering has been performed on the exhaust outlet. When welding is performed on the exhaust outlet, the connecting tube should be also chamfered and butt welded. Furthermore, when SUS304 is used for the product, the piping thickness of the exhaust outlet will be "Sch40".

### Screw holes on the exhaust port

Two M5-sized screw holes are opened on either side of the exhaust port, intended for use with the standard duct connection.

### Piping Installation 4: Water Inlet and Outlet Piping

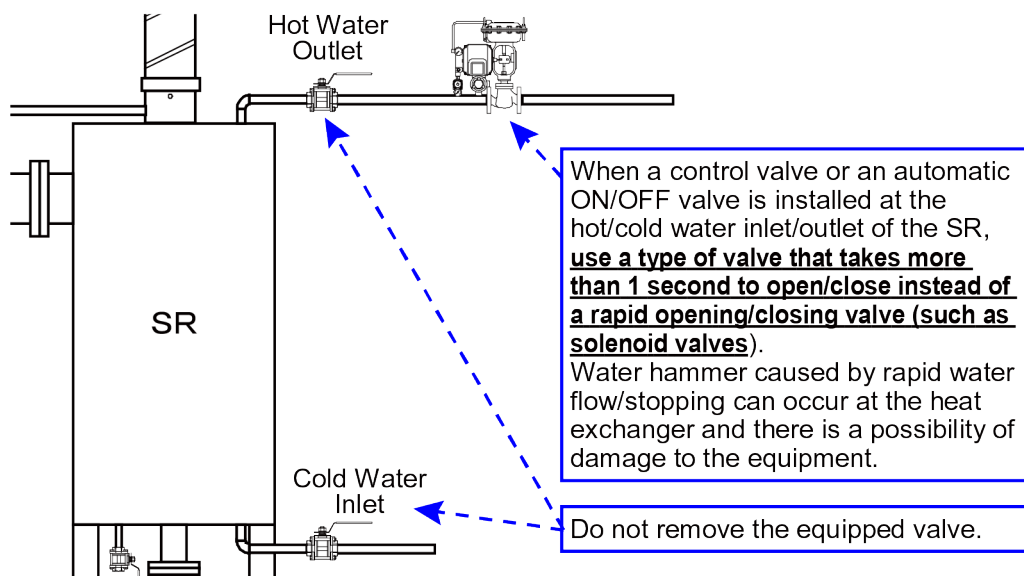



## Other cautions

Connect the cold water piping to the cold water inlet, and connect return piping from the hot water outlet to an area where the hot water can be utilized. To secure an adequate amount of cold feed water, make sure that the hydraulic pressure differential (pressure differential between inlet and outlet) is at least equal to the values in the following table. However, the water pressure must not exceed the maximum operating water pressure of 1.0 MPaG (150 psig).

Required Cold Water (t/h (lb/h))		Hydraulic Pressure Differential (MPa (psig))			
		SR-3		SR-8	
1	(2000)	0.03	(4.4)	—	—
2	(4000)	0.11	(15.9)	—	—
3	(6000)	0.23	(33.4)	0.03	(4.4)
4	(8000)	0.40	(58.0)	0.05	(7.3)
5	(10000)	0.62	(89.9)	0.07	(10.2)
6	(12000)	—	—	0.10	(14.5)
8	(16000)	—	—	0.17	(24.7)
10	(20000)	—	—	0.27	(39.2)
12	(24000)	—	—	0.38	(55.1)
14	(28000)	—	—	0.60	(87.0)

The diameter of the pipe before and after the product varies with the required amount of cold water, and it should be sized so that the velocity of cold water is 2 to 3 m/sec (6.6 to 9.8 ft/sec). Suggested diameters for the cold water inlet and hot water outlet piping are as follows:

Water Flow (t/h (lb/h))		Pipe Diameter (mm (in))	
1	(2000)	15	(1/2)
2	(4000)	15	(1/2)
3	(6000)	20	(3/4)
4	(8000)	25	(1)
5	(10000)	25	(1)
6	(12000)	32	(1 1/4)
7	(14000)	32	(1 1/4)
8	(16000)	32	(1 1/4)
10	(20000)	40	(1 1/2)

# Operation



## Caution

**Install properly and DO NOT use this product outside the recommended operating pressure, temperature and other specification ranges.** Improper use may result in such hazards as damage to the product or malfunctions that may lead to serious accidents. Local regulations may restrict the use of this product to below the conditions quoted.

**Take measures to prevent people from coming into direct contact with product outlets.** Failure to do so may result in burns or other injury from the discharge of fluids.

**Operate valves slowly and carefully.** Opening or closing valves too quickly may cause water hammer to occur, the impact of which could cause damage to equipment.

## To be performed after installation and before initial operation

- Make sure to flush the piping to remove welding slag, metal powder and filings.
- Make sure that flange bolts etc. are securely tightened before passing steam/water through the product.
- When conducting the test operation, start with a low steam and water flow rate and gradually increase the load to normal operating conditions. If you start with a normal operating load at the outset and there is a leak somewhere in the piping, there is a risk of steam or water blowing out.

## Startup

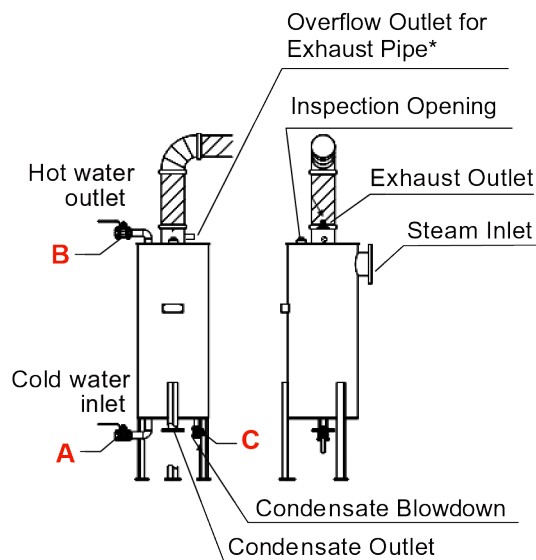

Make sure that the cold water inlet valve **A** and hot water outlet valve **B** are open before supplying waste steam to the SR. If waste steam is supplied while the cold water inlet valve **A** and hot water outlet valve **B** are closed, the pressure inside the coil will increase due to volume expansion, which could damage the cold water inlet valve **A** and hot water outlet valve **B**.

1. Make sure that the blow valve **C** in the base of the SR is closed.
2. Open the cold water inlet valve **A** and the hot water outlet valve **B**, allowing water to pass through the SR. In cases where either TIC (temperature control of heated water) or FIC (flow control of heated water) is used, start up the controls.
3. Open the condensate outlet valve, if any.

4. Open the steam inlet valve, if any.
5. Startup the equipment to allow waste steam to enter the SR.

Make sure that there are no abnormal discharges from the exhaust outlet or overflow outlet for exhaust pipe\*, such as blowing steam or condensate. If there is condensate blowing, or an abnormal sound or vibration, halt operation immediately.

The first time you operate the SR, or when operating with the condensate blow valve **C** open, waste steam may be discharged to the atmosphere through the exhaust outlet or overflow outlet for exhaust pipe <sup>1</sup> immediately after initiating operation, due to the lack of pooled condensate in the base to create an airtight water seal over the condensate outlet. (If steam blow stops shortly then everything is normal.)

### **Shutdown**

1. Stop the equipment, making sure that there is no flow of waste steam.
2. Close the cold water inlet valve **A** and the hot water outlet valve **B** to stop the inflow of cold water. At this point, make sure to close the valve slowly not rapidly. (If the valve is closed rapidly, water hammer will occur, resulting in impacts to the SR and the surrounding piping.)
3. When the SR is to be shutdown for long periods of time, discharge all condensate by opening the blow valve **C** at the bottom of the body.

---

<sup>1</sup>Depending on the specifications, the product may or may not feature an overflow outlet for the exhaust pipe.

# Inspection and Maintenance



## Caution

**Take measures to prevent people from coming into direct contact with product outlets.** Failure to do so may result in burns or other injury from the discharge of fluids.

**Be sure to use only the recommended components when repairing the product, and NEVER attempt to modify the product in any way.** Failure to observe these precautions may result in damage to the product and burns or other injury due to malfunction or the discharge of fluids.

As the SR is an atmospheric type heat exchanger, there is no particular need to perform the kind of maintenance inspections required for pressure vessels. However, if the heat exchanging performance declines, verify that the cold water and steam flow quantity are in compliance with the rated capacities. If they are not in compliance, correct the flow quantities. If there are no irregularities with the flow quantities, perform the following inspection:

Annual inspection and cleaning is recommended to prolong the product's service life.

### Inspection at cold/hot water side

Perform a reverse-flow chemical cleaning by pouring cleaning solution in through the hot water outlet valve on the SR, then discharging the solution through the cold water inlet valve.

### Inspection at steam side

Remove the plug from the inspection opening and check the condition inside the tank.

If the inspection reveals heavy grime, close the condensate outlet and the condensate blowdown outlet and perform chemical cleaning by pouring cleaning solution through the exhaust outlet of the SR.

# Troubleshooting

When the product fails to operate properly, use the following table to locate the cause and remedy.

<b>Problem</b>	<b>Cause</b>	<b>Remedy</b>
Steam or condensate blows from the exhaust outlet or the overflow outlet for exhaust pipe	Little or no flow of cold water for heat recovery	Correct water flow
	Steam flow exceeds rated capacities	Control the flow or add another heat exchanger
	Accumulation of scale, etc. on the heat transfer coils	Clean
The heat-recovery water does not become hot	Not enough steam flow	Secure the proper steam flow
	Quantity of cold water for heat-recovery is too great	Reduce flow
	Accumulation of scale, etc. on the heat transfer coils	Clean
There is back-pressure on the steam-using equipment, or steam cannot be discharged smoothly	There is a clog in the waste steam inlet piping	Remove the clog Check piping arrangement
	Little or no flow of water for heat recovery	Correct water flow
	Accumulation of scale, etc. on the heat transfer coils	Clean
	Incorrect piping at exhaust outlet	Correct the piping; see the "Piping Installation 3" section

# TLV EXPRESS LIMITED WARRANTY

Subject to the limitations set forth below, TLV CO., LTD., a Japanese corporation ("**TLV**"), warrants that products which are sold by it, TLV International Inc. ("**TII**") or one of its group companies excluding TLV Corporation (a corporation of the United States of America), (hereinafter the "**Products**") are designed and manufactured by TLV, conform to the specifications published by TLV for the corresponding part numbers (the "**Specifications**") and are free from defective workmanship and materials. The party from whom the Products were purchased shall be known hereinafter as the "**Seller**". With regard to products or components manufactured by unrelated third parties (the "**Components**"), TLV provides no warranty other than the warranty from the third party manufacturer(s), if any.

## Exceptions to Warranty

This warranty does not cover defects or failures caused by:

1. improper shipping, installation, use, handling, etc., by persons other than TLV, TII or TLV group company personnel, or service representatives authorized by TLV; or
2. dirt, scale or rust, etc.; or
3. improper disassembly and reassembly, or inadequate inspection and maintenance by persons other than TLV or TLV group company personnel, or service representatives authorized by TLV; or
4. disasters or forces of nature or Acts of God; or
5. abuse, abnormal use, accidents or any other cause beyond the control of TLV, TII or TLV group companies; or
6. improper storage, maintenance or repair; or
7. operation of the Products not in accordance with instructions issued with the Products or with accepted industry practices; or
8. use for a purpose or in a manner for which the Products were not intended; or
9. use of the Products in a manner inconsistent with the Specifications; or
10. use of the Products with Hazardous Fluids (fluids other than steam, air, water, nitrogen, carbon dioxide and inert gases (helium, neon, argon, krypton, xenon and radon)); or
11. failure to follow the instructions contained in the TLV Instruction Manual for the Product.

## Duration of Warranty

This warranty is effective for a period of one (1) year after delivery of Products to the first end user. Notwithstanding the foregoing, asserting a claim under this warranty must be brought within three (3) years after the date of delivery to the initial buyer if not sold initially to the first end user.

ANY IMPLIED WARRANTIES NOT NEGATED HEREBY WHICH MAY ARISE BY OPERATION OF LAW, INCLUDING THE IMPLIED WARRANTIES OF MERCHANTABILITY AND FITNESS FOR A PARTICULAR PURPOSE AND ANY EXPRESS WARRANTIES NOT NEGATED HEREBY, ARE GIVEN SOLELY TO THE INITIAL BUYER AND ARE LIMITED IN DURATION TO ONE (1) YEAR FROM THE DATE OF SHIPMENT BY THE SELLER.

## Exclusive Remedy

THE EXCLUSIVE REMEDY UNDER THIS WARRANTY, UNDER ANY EXPRESS WARRANTY OR UNDER ANY IMPLIED WARRANTIES NOT NEGATED HEREBY (INCLUDING THE IMPLIED WARRANTIES OF MERCHANTABILITY AND FITNESS FOR A PARTICULAR PURPOSE), IS **REPLACEMENT**; PROVIDED: (a) THE CLAIMED DEFECT IS

REPORTED TO THE SELLER IN WRITING WITHIN THE WARRANTY PERIOD, INCLUDING A DETAILED WRITTEN DESCRIPTION OF THE CLAIMED DEFECT AND HOW AND WHEN THE CLAIMED DEFECTIVE PRODUCT WAS USED; AND (b) THE CLAIMED DEFECTIVE PRODUCT AND A COPY OF THE PURCHASE INVOICE IS RETURNED TO THE SELLER, FREIGHT AND TRANSPORTATION COSTS PREPAID, UNDER A RETURN MATERIAL AUTHORIZATION AND TRACKING NUMBER ISSUED BY THE SELLER. ALL LABOR COSTS, SHIPPING COSTS, AND TRANSPORTATION COSTS ASSOCIATED WITH THE RETURN OR REPLACEMENT OF THE CLAIMED DEFECTIVE PRODUCT ARE SOLELY THE RESPONSIBILITY OF BUYER OR THE FIRST END USER. THE SELLER RESERVES THE RIGHT TO INSPECT ON THE FIRST END USER'S SITE ANY PRODUCTS CLAIMED TO BE DEFECTIVE BEFORE ISSUING A RETURN MATERIAL AUTHORIZATION. SHOULD SUCH INSPECTION REVEAL, IN THE SELLER'S REASONABLE DISCRETION, THAT THE CLAIMED DEFECT IS NOT COVERED BY THIS WARRANTY, THE PARTY ASSERTING THIS WARRANTY SHALL PAY THE SELLER FOR THE TIME AND EXPENSES RELATED TO SUCH ON-SITE INSPECTION.

### **Exclusion of Consequential and Incidental Damages**

IT IS SPECIFICALLY ACKNOWLEDGED THAT THIS WARRANTY, ANY OTHER EXPRESS WARRANTY NOT NEGATED HEREBY, AND ANY IMPLIED WARRANTY NOT NEGATED HEREBY, INCLUDING THE IMPLIED WARRANTIES OF MERCHANTABILITY AND FITNESS FOR A PARTICULAR PURPOSE, DO NOT COVER, AND NEITHER TLV, TII NOR ITS TLV GROUP COMPANIES WILL IN ANY EVENT BE LIABLE FOR, INCIDENTAL OR CONSEQUENTIAL DAMAGES, INCLUDING, BUT NOT LIMITED TO LOST PROFITS, THE COST OF DISASSEMBLY AND SHIPMENT OF THE DEFECTIVE PRODUCT, INJURY TO OTHER PROPERTY, DAMAGE TO BUYER'S OR THE FIRST END USER'S PRODUCT, DAMAGE TO BUYER'S OR THE FIRST END USER'S PROCESSES, LOSS OF USE, OR OTHER COMMERCIAL LOSSES. WHERE, DUE TO OPERATION OF LAW, CONSEQUENTIAL AND INCIDENTAL DAMAGES UNDER THIS WARRANTY, UNDER ANY OTHER EXPRESS WARRANTY NOT NEGATED HEREBY OR UNDER ANY IMPLIED WARRANTY NOT NEGATED HEREBY (INCLUDING THE IMPLIED WARRANTIES OF MERCHANTABILITY AND FITNESS FOR A PARTICULAR PURPOSE) CANNOT BE EXCLUDED, SUCH DAMAGES ARE EXPRESSLY LIMITED IN AMOUNT TO THE PURCHASE PRICE OF THE DEFECTIVE PRODUCT. THIS EXCLUSION OF CONSEQUENTIAL AND INCIDENTAL DAMAGES, AND THE PROVISION OF THIS WARRANTY LIMITING REMEDIES HEREUNDER TO REPLACEMENT, ARE INDEPENDENT PROVISIONS, AND ANY DETERMINATION THAT THE LIMITATION OF REMEDIES FAILS OF ITS ESSENTIAL PURPOSE OR ANY OTHER DETERMINATION THAT EITHER OF THE ABOVE REMEDIES IS UNENFORCEABLE, SHALL NOT BE CONSTRUED TO MAKE THE OTHER PROVISIONS UNENFORCEABLE.

### **Exclusion of Other Warranties**

THIS WARRANTY IS IN LIEU OF ALL OTHER WARRANTIES, EXPRESS OR IMPLIED, AND ALL OTHER WARRANTIES, INCLUDING BUT NOT LIMITED TO THE IMPLIED WARRANTIES OF MERCHANTABILITY AND FITNESS FOR A PARTICULAR PURPOSE, ARE EXPRESSLY DISCLAIMED.

### **Severability**

Any provision of this warranty which is invalid, prohibited or unenforceable in any jurisdiction shall, as to such jurisdiction, be ineffective to the extent of such invalidity, prohibition or unenforceability without invalidating the remaining provisions hereof, and any such invalidity, prohibition or unenforceability in any such jurisdiction shall not invalidate or render unenforceable such provision in any other jurisdiction.

## Service

For Service or Technical Assistance: Contact your TLV representative or your regional TLV office.

### In Europe:

#### **TLV EURO ENGINEERING GmbH**

Daimler-Benz-Straße 16-18, 74915 Waibstadt, **Germany**

Tel: [49]-(0)7263-9150-0

#### **TLV EURO ENGINEERING UK LTD.**

Units 7 & 8, Furlong Business Park, Bishops Cleeve,  
Gloucestershire GL52 8TW, **U.K.**

Tel: [44]-(0)1242-227223

#### **TLV EURO ENGINEERING FRANCE SARL**

Parc d'Ariane 2, bât. C, 290 rue Ferdinand Perrier, 69800 Saint  
Priest, **France**

Tel: [33]-(0)4-72482222

Fax: [33]-(0)4-72482220

### In North America:

#### **TLV CORPORATION**

13901 South Lakes Drive, Charlotte, NC 28273-6790, **U.S.A.**

Tel: [1]-704-597-9070

Fax: [1]-704-583-1610

#### **TLV ENGINEERING S. A. DE C.V.**

Av. Jesús del Monte 39-B-1001, Col. Hda. de las Palmas,  
Huixquilucan, Edo. de México, 52763, **Mexico**

Tel: [52]-55-5359-7949

Fax: [52]-55-5359-7585

### In Oceania:

#### **TLV PTY LIMITED**

Unit 8, 137-145 Rooks Road, Nunawading, Victoria 3131,  
**Australia**

Tel: [61]-(0)3-9873 5610

Fax: [61]-(0)3-9873 5010

### In East Asia:

#### **TLV PTE LTD**

36 Kaki Bukit Place, #02-01/02, **Singapore** 416214

Tel: [65]-6747 4600

Fax: [65]-6742 0345

#### **TLV SHANGHAI CO., LTD.**

5/F, Building 7, No.103 Caobao Road, Xuhui District, Shanghai,  
**China** 200233

Tel: [86]-(0)21-6482-8622

Fax: [86]-(0)21-6482-8623

#### **TLV ENGINEERING SDN. BHD.**

No.16, Jalan MJ14, Taman Industri Meranti Jaya, 47120  
Puchong, Selangor, **Malaysia**

Tel: [60]-3-8052-2928

Fax: [60]-3-8051-0899

#### **TLV PRIVATE LIMITED**

252/94 (K-L) 17th Floor, Muang Thai-Phatra Complex Tower B,  
Rachadaphisek Road, Huaykwang, Bangkok 10310, **Thailand**

Tel: [66]-2-693-3799

Fax: [66]-2-693-3979

#### **TLV INC.**

#302-1 Bundang Technopark B, 723 Pangyo-ro, Bundang,  
Seongnam, Gyeonggi, 13511, **Korea**

Tel: [82]-(0)31-726-2105

Fax: [82]-(0)31-726-2195

### In the Middle East:

#### **TLV ENGINEERING FZCO**

Building 9W, B163, PO Box 371684, Dubai Airport Free Zone,  
Dubai, **UAE**

Email: sales-me@tlv.co.jp

### In Other Countries:

#### **TLV INTERNATIONAL, INC.**

881 Nagasuna, Noguchi, Kakogawa, Hyogo 675-8511, **Japan**

Tel: [81]-(0)79-427-1818

Fax: [81]-(0)79-425-1167

### Manufacturer:

#### **TLV CO., LTD.**

881 Nagasuna, Noguchi, Kakogawa, Hyogo 675-8511, **Japan**

Tel: [81]-(0)79-427-1800

Fax: [81]-(0)79-422-2277