

ISO 9001
ISO14001



Manufacturer

TLV CO., LTD.

Kakogawa, Japan

is approved by LRQA Ltd. to ISO 9001:2001



Instruction Manual

Process Float Steam Trap

Featured Models: JL14-X/JLH14-X

Optional Mode: JLH14-B

172-65441M-07

Publication date 19 February 2024

Copyright © 2024 TLV CO., LTD.

Table of Contents

- Introduction 3
- Safety Considerations 4
- Checking the Piping 6
- Specifications 7
- Configuration 8
- Installation 10
- Maintenance 12
- Disassembly/Reassembly 13
- Troubleshooting 19
- TLV EXPRESS LIMITED WARRANTY 22
- Service 24

Introduction

Thank you for purchasing the TLV process float steam trap.

This product has been thoroughly inspected before being shipped from the factory. When the product is delivered, before doing anything else, check the specifications and external appearance to make sure nothing is out of the ordinary. Also be sure to read this manual carefully before use and follow the instructions to be sure of using the product properly.

The process float steam trap is a large-capacity lever float type mechanical steam trap that uses a high-performance X-element for the air vent. With the unique sensitivity of mechanical steam traps for condensate discharge, the trap reduces the time required to start up process equipment and improves heating efficiency.

If detailed instructions for special order specifications or options not contained in this manual are required, please contact TLV for full details.

This instruction manual is intended for use with the model(s) listed on the front cover. It is necessary not only for installation, but for subsequent maintenance, disassembly/reassembly and troubleshooting. Please keep it in a safe place for future reference.

Safety Considerations

- Read this section carefully before use and be sure to follow the instructions.
- Installation, inspection, maintenance, repairs, disassembly, adjustment and valve opening/closing should be carried out only by trained maintenance personnel.
- The precautions listed in this manual are designed to ensure safety and prevent equipment damage and personal injury. For situations that may occur as a result of erroneous handling, three different types of cautionary items are used to indicate the degree of urgency and the scale of potential damage and danger: DANGER, WARNING and CAUTION.
- The three types of cautionary items above are very important for safety: be sure to observe all of them as they relate to installation, use, maintenance and repair. Furthermore, TLV accepts no responsibility for any accidents or damage occurring as a result of failure to observe these precautions.

Cautionary items and definitions



Danger

Indicates an urgent situation which poses a threat of death or serious injury



Warning

Indicates that there is a potential threat of death or serious injury



Caution

Indicates that there is a possibility of injury or equipment/product damage

Safety Considerations for the Product



Warning

NEVER apply direct heat to the float. The float may explode due to increased internal pressure, causing accidents leading to serious injury or damage to property and equipment.



Caution

Install properly and DO NOT use this product outside the recommended operating pressure, temperature and other specification ranges. Improper use may result in such hazards as damage to the product or malfunctions that may lead to serious accidents. Local regulations may restrict the use of this product to below the conditions quoted.



Caution

DO NOT use this product in excess of the maximum operating pressure differential. Such use could make discharge impossible (blocked).



Caution

Use hoisting equipment for heavy objects (weighing approximately 20 kg (44 lb) or more). Failure to do so may result in back strain or other injury if the object should fall.



Caution

Take measures to prevent people from coming into direct contact with product outlets. Failure to do so may result in burns or other injury from the discharge of fluids.



Caution

When disassembling or removing the product, wait until the internal pressure equals atmospheric pressure and the surface of the product has cooled to room temperature. Disassembling or removing the product when it is hot or under pressure may lead to discharge of fluids, causing burns, other injuries or damage.



Caution

Be sure to use only the recommended components when repairing the product, and NEVER attempt to modify the product in any way. Failure to observe these precautions may result in damage to the product and burns or other injury due to malfunction or the discharge of fluids.



Caution

Do not use excessive force when connecting threaded pipes to the product. Over-tightening may cause breakage leading to fluid discharge, which may cause burns or other injury.



Caution

Use only under conditions in which no freeze-up will occur. Freezing may damage the product, leading to fluid discharge, which may cause burns or other injury.



Caution

Use only under conditions in which no water hammer will occur. The impact of water hammer may damage the product, leading to fluid discharge, which may cause burns or other injury.

Checking the Piping



Caution

Use only under conditions in which no water hammer will occur. The impact of water hammer may damage the product, leading to fluid discharge, which may cause burns or other injury.

Check to make sure that the pipes to be connected to the product have been installed properly.

1. Is the pipe diameter suitable?
2. Is the piping where the product is to be installed horizontal?
3. Has sufficient space been secured for maintenance?
(refer to the “Installation” section)
4. Have isolation valves been installed at the inlet and outlet? If the outlet is subject to back pressure, has a check valve been installed?
5. Is the inlet pipe as short as possible, with as few bends as possible, and installed so the liquid will flow naturally down into the product?
6. Has the piping work been done correctly, as shown in the figures below?

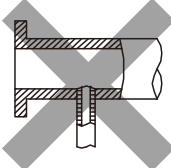
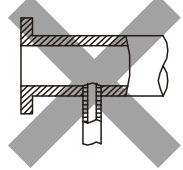
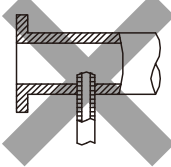
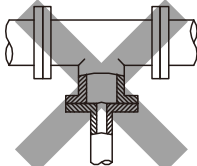
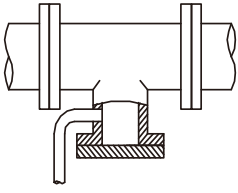
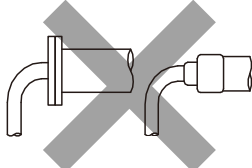
Requirement	Correct	Incorrect
Install catchpot with the proper diameter.		 Diameter is too small.
Make sure the flow of condensate is not obstructed.		 Diameter is too small and inlet protrudes into pipe interior.
To prevent rust and scale from flowing into the product, the inlet pipe should be connected 25 to 50 mm above the base of the T-pipe.		 Rust and scale flow into the trap with the condensate.
When installing on the blind end, make sure the flow of condensate is not obstructed.		 Condensate collects in the pipe.

Specifications



Caution

Install properly and DO NOT use this product outside the recommended operating pressure, temperature and other specification ranges. Improper use may result in such hazards as damage to the product or malfunctions that may lead to serious accidents. Local regulations may restrict the use of this product to below the conditions quoted.

DO NOT use this product in excess of the maximum operating pressure differential. Such use could make discharge impossible (blocked).

Use only under conditions in which no freeze-up will occur. Freezing may damage the product, leading to fluid discharge, which may cause burns or other injury.

Refer to the product nameplate for detailed specifications.

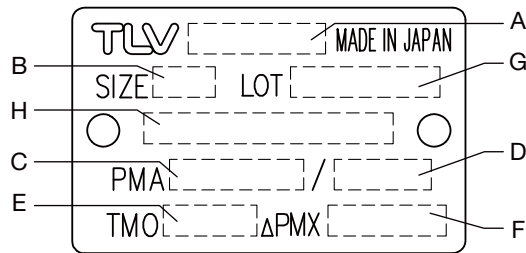

A	Model	E	Maximum Operating Temperature (TMO)
B	Nominal Diameter	F	Maximum Differential Pressure (PMX)
C	Maximum Allowable Pressure (PMA) ⁰¹	G	Production Lot No.
D	Maximum Allowable Temperature (TMA) ⁰¹	H	Valve No. ⁰²

⁰¹Maximum allowable pressure (PMA) and maximum allowable temperature (TMA) are PRESSURE SHELL DESIGN CONDITIONS, **NOT** OPERATING CONDITIONS.

⁰²Valve No. is displayed for products with options. This item is omitted from the nameplate when there are no options.

Configuration

JL14-X

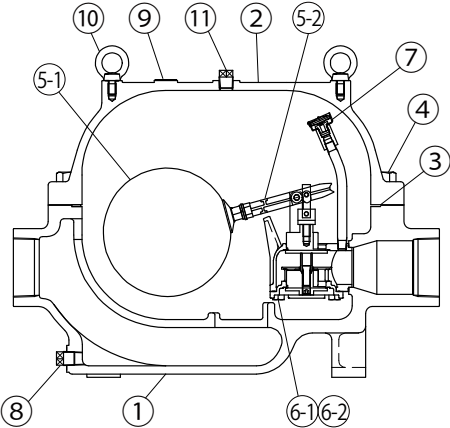

No.	Part Name	A ⁰¹	B ⁰¹	C ⁰¹	D ⁰¹	E ⁰²
1	Body					
2	Cover					
3	Cover Gasket	✓	✓	✓	✓	
4	Cover Bolt					
5-1	Float					✓
5-2	Lever Unit		✓			
6-1	Trap Unit (Main Valve Unit) ⁰³			✓		
6-2	Valve Seat Gasket	✓		✓ ⁰⁴		
7	Air Vent Unit				✓	
8	Drain Plug					
9	Nameplate					
10	Eye Bolt					
11	Cover Plug					

⁰¹Replacement parts are available only in the following kits: A = Maintenance Kit, B = Lever Repair Kit, C = Trap Repair Kit, D= Air Vent Repair Kit

⁰²E= Float

⁰³Trap Unit (Main Valve Unit) has a specific Orifice No.

⁰⁴Included in Trap Unit (Main Valve Unit)

JLH14-X, JLH14-B (option)

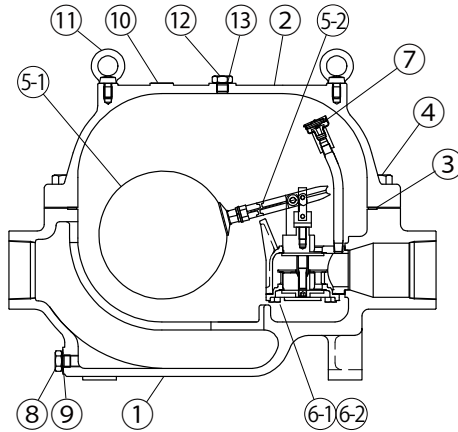

No.	Part Name	A ⁰¹	B ⁰¹	C ⁰¹	D ⁰¹	E ⁰²
1	Body					
2	Cover					
3	Cover Gasket	✓	✓	✓	✓	
4	Cover Bolt					
5-1	Float					✓
5-2	Lever Unit		✓			
6-1	Trap Unit (Main Valve Unit) ⁰³			✓		
6-2	Valve Seat Gasket	✓		✓ ⁰⁴		
7	Air Vent Unit ⁰⁵				✓	
8	Drain Plug					
9	Drain Plug Gasket	✓	✓	✓	✓	
10	Nameplate					
11	Eye Bolt					
12	Cover Plug					
13	Cover Plug Gasket	✓	✓	✓	✓	

⁰¹Replacement parts are available only in the following kits: A = Maintenance Kit, B = Lever Repair Kit, C = Trap Repair Kit, D= Air Vent Repair Kit

⁰²E= Float

⁰³Trap Unit (Main Valve Unit) has a specific Orifice No.

⁰⁴Included in Trap Unit (Main Valve Unit)

⁰⁵X-element Air Vent Unit (JLH14-X) is standard; Bimetal Air Vent Unit (JLH14-B) is an option

Installation



Caution

Install properly and DO NOT use this product outside the recommended operating pressure, temperature and other specification ranges. Improper use may result in such hazards as damage to the product or malfunctions that may lead to serious accidents. Local regulations may restrict the use of this product to below the conditions quoted.

Use hoisting equipment for heavy objects (weighing approximately 20 kg (44 lb) or more). Failure to do so may result in back strain or other injury if the object should fall.

Take measures to prevent people from coming into direct contact with product outlets. Failure to do so may result in burns or other injury from the discharge of fluids.

Do not use excessive force when connecting threaded pipes to the product. Over-tightening may cause breakage leading to fluid discharge, which may cause burns or other injury.

Installation, inspection, maintenance, repairs, disassembly, adjustment and valve opening/closing should be carried out only by trained maintenance personnel.

1. Before installation, be sure to remove all protective seals.
2. Before installing the product, open the inlet valve and blow out the piping to remove any piping scraps, dirt and oil. Close the inlet valve after blowdown.
3. Install a bypass valve and inlet and outlet isolation valves for use in the event of trap failure or when performing maintenance.
4. Install a strainer (40 to 60 mesh) ahead of the product.
5. Install the product so the arrow on the body is pointing in the direction of condensate flow.
6. The product should be inclined no more than 5° horizontally and front-to-back. Be sure to leave adequate clearance for a maintenance space (a) (at least 300 mm) above the trap cover.
7. Connect outlet piping. Be sure to size outlet piping large enough to accommodate any flash steam that may form to prevent any increase in back pressure and allow at least 1 m straight piping to avoid possible pipe erosion.
8. Open the inlet and outlet valves and check to make sure that the product functions properly.

If there is a problem, determine the cause using the “Troubleshooting” section in this manual.

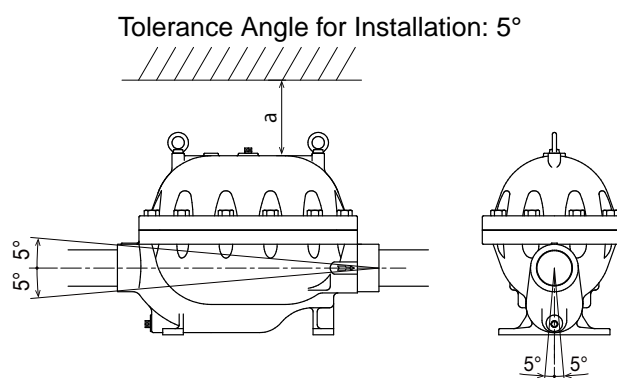

Make sure the product is installed with the raised TLV lettering on the body horizontal.

Sample Installation

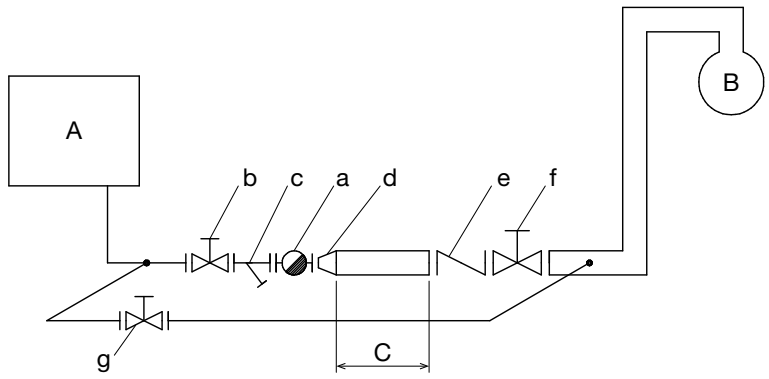

- a: JL14-X/JLH14-X/JLH14-B (option)
- b: Inlet Valve
- c: Strainer
- d: Reducer
- e: Check Valve
- f: Outlet Valve
- g: Bypass Valve
- A: Steam-using Equipment
- B: Condensate Recovery Line
- C: Straight piping 1 m



Note

Be sure to size outlet piping large enough to accommodate any flash steam that may form to prevent any increase in back pressure.

(Outlet pipe size should always be properly calculated, contact TLV for assistance.) Inlet, outlet and bypass valves must be full bore valves.

This diagram is for illustration purposes only. For actual installation, piping design must be performed by qualified personnel.

Maintenance



Caution

Take measures to prevent people from coming into direct contact with product outlets. Failure to do so may result in burns or other injury from the discharge of fluids.

Be sure to use only the recommended components when repairing the product, and NEVER attempt to modify the product in any way. Failure to observe these precautions may result in damage to the product and burns or other injury due to malfunction or the discharge of fluids.

Operational Check

A visual inspection of the following items should be done on a daily basis to determine whether the product is operating properly or has failed. Periodically (at least biannually) the operation should also be checked by using diagnostic equipment, such as a stethoscope, thermometer, TLV Pocket TrapMan or TLV TrapMan.

If the product should fail, it may cause damage to piping and equipment, resulting in faulty or low quality products or losses due to steam leakage.

Normal:	Condensate is discharged continuously, together with flash steam, and the sound of flow can be heard. If there is very little condensate, there is almost no sound of flow.
Blocked (Discharge Impossible):	No condensate is discharged. The product is quiet and makes no noise, and the surface temperature of the product is low.
Blowing:	Live steam continually flows from the outlet and there is a continuous metallic sound.
Steam Leakage:	Live steam is discharged through the product outlet together with condensate, accompanied by a high-pitched sound.



Note

JL14-X, JLN14-X and JLN14-B (option) have a minimum required condensate load requirement to ensure proper sealing.

Parts Inspection

When parts have been removed, or during periodic inspections, use the following table to inspect the parts and replace any that are found to be defective.

Gaskets (Cover, Valve Seat): check for warping or scratches

Main Joint Stem and Joint Bolt for Lever Unit and Trap Unit (Main Valve Unit): Check for wear

Float/Lever Unit: Check sliding sections for any dirt, oil film or wear that may impede smooth movement; make sure the lever moves smoothly

Valve Opening in Trap Unit (Main Valve Unit): Check for dirt, oil film, wear or scratches that may impair sealing; make sure the valve moves up and down smoothly

Air Vent Valve Seat: Check for scratches

X-element in Air Vent: Check for damage

Float: Check for deformation, scratches or dents

Piston Ring: Check for damage and wear

Disassembly/Reassembly



Warning

NEVER apply direct heat to the float. The float may explode due to increased internal pressure, causing accidents leading to serious injury or damage to property and equipment.



Caution

Use hoisting equipment for heavy objects (weighing approximately 20 kg (44 lb) or more). Failure to do so may result in back strain or other injury if the object should fall.

When disassembling or removing the product, wait until the internal pressure equals atmospheric pressure and the surface of the product has cooled to room temperature.

Disassembling or removing the product when it is hot or under pressure may lead to discharge of fluids, causing burns, other injuries or damage.

Use the following procedures to remove components. Use the same procedures in reverse to reassemble.

(Installation, inspection, maintenance, repairs, disassembly, adjustment and valve opening/closing should be carried out only by trained maintenance personnel.)

In cases where sufficient space has been secured for maintenance (see the maintenance space diagram in the “Installation” section), it is possible to perform maintenance without disconnecting the inlet and outlet piping. If there is insufficient maintenance space, first disconnect the inlet and outlet piping, then move the unit to a spacious area in which to carry out maintenance.

Removing/Reattaching the Drain Plug

Remove any condensate from inside the body before beginning disassembly.

Part Name & No.	During Disassembly	During Reassembly
Drain Plug 8	Remove with a wrench	JL14-X: Wrap 3 to 3.5 turns of sealing tape around the threads or coat with sealing compound; consult the table of tightening torques and tighten to the proper torque JLH14-X/JLH14-B (Option): Consult the table of tightening torques and tighten to the proper torque
Drain Plug Gasket 9 (JLH14-X/ JLH14-B (Option))	Remove the gasket and clean sealing surfaces	Replace with a new gasket; coat surfaces with anti-seize

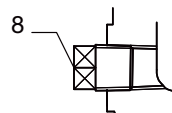
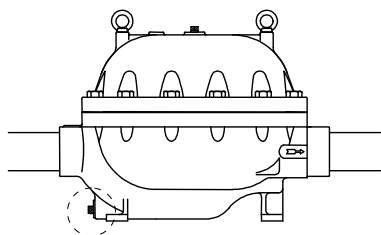

JL14-X

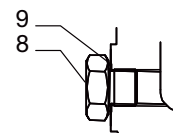

JLH14-X/JLH14-B (option)

Detaching/Reattaching the Cover from the Body

Part Name & No.	During Disassembly	During Reassembly
Cover Bolt 4 (M22 x 12 pcs)	Remove with a socket wrench	Consult the table of tightening torques and tighten evenly to the proper torque
Cover 2	Lift up to remove	Make sure to match the direction of the arrow indicated on the body and the cover
Cover Gasket 3	Remove the gasket and clean sealing surfaces	Replace with a new gasket

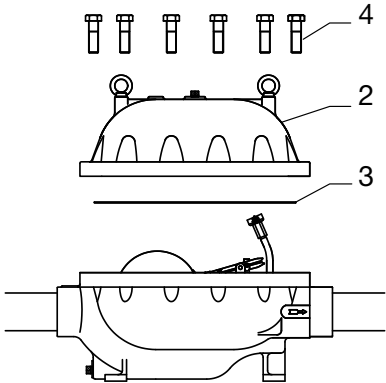

Disassembly/Reassembly of the Air Vent Unit, Connector and Air Vent Pipe

Part Name & No.	During Disassembly	During Reassembly
Air Vent Pipe 7-a	Remove with a pipe wrench	Wrap 3 to 3.5 turns of sealing tape around the threads or coat with sealing compound and screw into trap unit (main valve unit) Consult the table of tightening torques and tighten to the proper torque
Connector 7-b	Remove with a wrench	Consult the table of tightening torques and tighten to the proper torque
Spring Clip 7-c	Pinch insides together and remove from the X-element guide	Insert securely into the groove in the X-element guide
X-element 7-d	Remove from the X-element guide	Reinsert after making sure of the proper orientation
Air Vent Valve Seat 7-e	Remove with a socket wrench	Consult the table of tightening torques and tighten to the proper torque
X-element Guide 7-f	Remove without bending	The X-element must be inserted smoothly
Snap Ring 7-g ⁰¹	Pinch insides together and remove from the air vent case	Insert securely into the groove in the air vent case
Air Vent Screen 7-h ⁰¹	Remove being careful not to misshape	Replace, being careful not to misshape
Bimetal Plate 7-i ⁰¹ (Air Vent Valve Plug 7-j ⁰¹) (Snap Ring 7-k ⁰¹)	Remove air vent parts from the air vent case	Make sure to reinsert in the proper orientation; make sure the seating surface of the air vent valve is facing towards the air vent valve seat
Air Vent Case 7-l ⁰¹	Remove from seating	Check for scratches or dirt on seating surface

⁰¹JLH14-B (option)

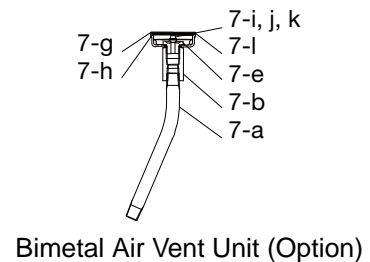
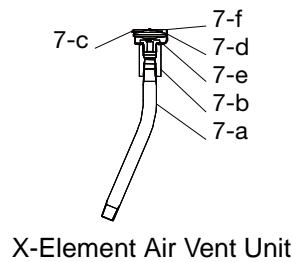
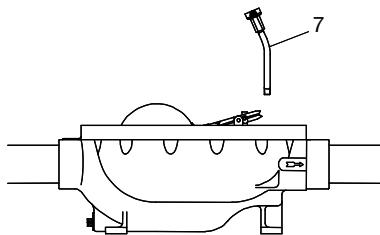

Detaching/Reattaching the Float and the Trap Unit

Part Name & No.	During Disassembly	During Reassembly
Float 5-1	Hold the lever firmly with a wrench Remove the float with a second wrench	Hold the lever (5-2a) firmly with a wrench Reattach the float Consult the table of tightening torques and tighten to the proper torque
Spring Washer 6-1a	Remove from the lever, do not misplace	Place the spring washer on the lever
Plain Washer 6-1b	Remove from the lever, do not misplace	Place the plain washer on the lever
Hex Bolt 6-1c (M12 x 2 pcs)	Remove with a socket wrench	Consult the table of tightening torques and tighten evenly to the proper torque
Spring Washer 6-1d	Be careful not to misplace	Be sure to reinsert the washers
Valve Seat Gasket 6-2	Remove the gasket and clean sealing surfaces	Replace with a new gasket

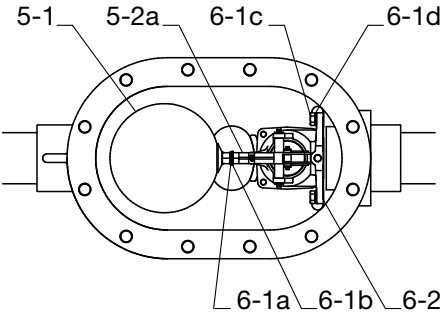

Detaching/Reattaching the Lever Unit & Float Unit

Part Name & No.	During Disassembly	During Reassembly
Lever Unit 5-2 Trap Unit 6-1	<p>Remove the split pin from each end of the main joint stem</p> <p>Loosen with a wrench and remove the U-nut used for the joint bolt</p> <p>Pull out the main joint stem</p> <p>Pull out the joint bolt, paying attention to the position of the flats on the joint bolt; the lever unit and the trap unit can then be separated</p>	<p>Ensure proper orientation for the lever unit at reassembly; Connect the lever unit to the trap unit with the "UP" mark facing upwards</p> <p>Referring to the figure below, insert both the main joint stem and the joint bolt; remember to reinsert the washers; once a new split pin is inserted into each end of the main joint stem, make sure to bend both ends of each split pin so it does not come off</p> <p>The flats on the joint bolt should be positioned as shown in the figure below; remember to reinsert the washers; make sure the flat surface of the U-nut is facing the washer at reassembly; consult the table of tightening torques and tighten to the proper torque</p>

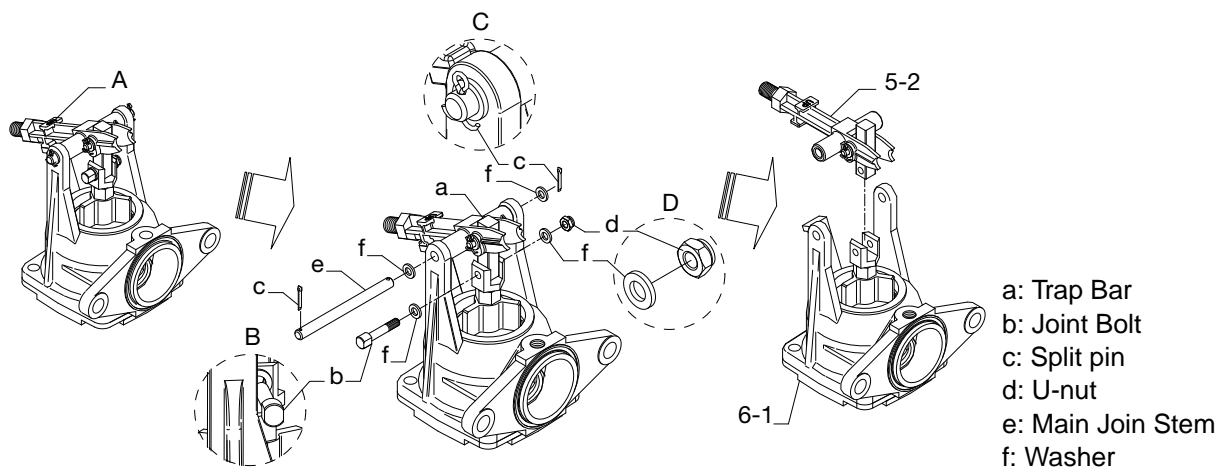

A: "UP" marking facing upwards

B: Pay attention to the position of the flats on the joint bolt at time of assembly

C: Make sure to insert a split pin into each end of the main join stem and bend the ends up at time of assembly

D: Make sure the flat surface of the U-nut is facing the washer at time of assembly

Table of Tightening Torques

Part Name & No.	Torque N-m	Distance Across Flats mm
Drain Plug 8 (JL14-X) Cover Plug 11 (JL14-X)	30 ⁰¹	12
Drain Plug 8 (JLH14-X, JLH14-B (option)) Cover Plug 12 (JLH14-X, JLH14-B (option))	100	26
Cover Bolt 4 (JL14-X)	200	32
Cover Bolt 4 (JLH14-X, JLH14-B (option))	600	32
Air Vent Pipe 7-a	30 ⁰¹	—
Connector 7-b	30	19
Air Vent Valve Seat 7-e (JL14-X, JLH14-X)	35	19
Air Vent Valve Seat 7-e (JLH14-B (option))	30	19
Float 5-1	50	19
Hex Bolt 6-1c	80	19
U-nut 5-2d (Joint Bolt 5-2b)	10	10

⁰¹These values represent tightening torques for threads that are wrapped with 3 to 3.5 turns of sealing tape.



Note

- Coat all threaded portions with anti-seize.
- If drawings or other special documentation were supplied for the product, any torque given there takes precedence over values shown here.

Troubleshooting



Warning

NEVER apply direct heat to the float. The float may explode due to increased internal pressure, causing accidents leading to serious injury or damage to property and equipment.



Caution

When disassembling or removing the product, wait until the internal pressure equals atmospheric pressure and the surface of the product has cooled to room temperature. Disassembling or removing the product when it is hot or under pressure may lead to discharge of fluids, causing burns, other injuries or damage.

When the product fails to operate properly, use the following table to locate the cause and remedy.

Problem	Cause	Remedy
No condensate is discharged (blocked) or discharge is poor	<p>Check to see if the operating conditions are outside the specification ranges:</p> <ul style="list-style-type: none"> • Is the pressure differential suitable for the amount of condensate generated? • Has the maximum operating pressure been exceeded? 	Compare specifications with actual operating conditions
	<p>Check to see if the trap installation method and location are suitable:</p> <ul style="list-style-type: none"> • Is the trap inlet pipe installed so the fluid flows downward naturally? • Are the sizes of the inlet and outlet pipes suitable? • Has steam-locking occurred? 	Change to a suitable piping arrangement
	<p>Check the inlet and outlet valve open/close status and check to see if the valve is clogged with dirt:</p> <ul style="list-style-type: none"> • Are the inlet and outlet valves fully open? • Is the inlet strainer clogged with dirt? • Are the pipes clogged with dirt? • - Is there accumulated dirt at the bottom of the body, particularly below the trap unit (main valve unit)? 	Inspect and clean
	<p>Check sliding sections of the lever unit:</p> <ul style="list-style-type: none"> • Is rust and/or scale obstructing movement of the lever unit? • Is the movement of the lever smooth? 	Clean or replace with a new lever unit
	<p>Check sliding sections of the trap unit (main valve unit):</p> <ul style="list-style-type: none"> • Is there rust and/or scale in the sliding sections? • Is the movement of the valve smooth? 	Clean or replace with a new trap unit (main valve unit)
	<p>Check the float to see if it is damaged or filled with water</p>	Replace with a new float

Problem	Cause	Remedy
Steam is discharged or leaks from the trap outlet (blowing) (steam leakage)	Check minimum required condensate amount: <ul style="list-style-type: none"> Actual condensate amount falls below minimum required amount 	Replace with a product that has a suitable capacity rating
	Check the trap unit (main valve unit): <ul style="list-style-type: none"> Check for a clogged valve opening or rust and scale under the float Check for damage to the valve opening Check for rust and scale in the sliding sections Is the movement of the valve smooth? Are the gaskets deteriorated or damaged? 	Clean or replace with new parts/trap units
	Check sliding sections of lever unit: <ul style="list-style-type: none"> Is rust and/or scale obstructing movement of the lever unit? Is the movement of the lever smooth? 	Clean or replace with a new lever unit
	Check the air vent: <ul style="list-style-type: none"> Check for damage to or rust and scale on the X-element or the bimetal 	Replace parts where necessary
	Check for proper installation	Install correctly
	Check for trap vibration	Lengthen the inlet piping and fasten it securely
Steam is leaking from a place other than the outlet	Check for gasket deterioration or damage	Replace with new gasket(s)
	Check to make sure that the proper tightening torques were used	Tighten to the proper torque
	Erosion has occurred in the body or cover	Replace with a new product
Float frequently becomes damaged	Check to see if water hammer has occurred	Study and correct the piping

TLV EXPRESS LIMITED WARRANTY

Subject to the limitations set forth below, TLV CO., LTD., a Japanese corporation ("**TLV**"), warrants that products which are sold by it, TLV International Inc. ("**TII**") or one of its group companies excluding TLV Corporation (a corporation of the United States of America), (hereinafter the "**Products**") are designed and manufactured by TLV, conform to the specifications published by TLV for the corresponding part numbers (the "**Specifications**") and are free from defective workmanship and materials. The party from whom the Products were purchased shall be known hereinafter as the "**Seller**". With regard to products or components manufactured by unrelated third parties (the "**Components**"), TLV provides no warranty other than the warranty from the third party manufacturer(s), if any.

Exceptions to Warranty

This warranty does not cover defects or failures caused by:

1. improper shipping, installation, use, handling, etc., by persons other than TLV, TII or TLV group company personnel, or service representatives authorized by TLV; or
2. dirt, scale or rust, etc.; or
3. improper disassembly and reassembly, or inadequate inspection and maintenance by persons other than TLV or TLV group company personnel, or service representatives authorized by TLV; or
4. disasters or forces of nature or Acts of God; or
5. abuse, abnormal use, accidents or any other cause beyond the control of TLV, TII or TLV group companies; or
6. improper storage, maintenance or repair; or
7. operation of the Products not in accordance with instructions issued with the Products or with accepted industry practices; or
8. use for a purpose or in a manner for which the Products were not intended; or
9. use of the Products in a manner inconsistent with the Specifications; or
10. use of the Products with Hazardous Fluids (fluids other than steam, air, water, nitrogen, carbon dioxide and inert gases (helium, neon, argon, krypton, xenon and radon)); or
11. failure to follow the instructions contained in the TLV Instruction Manual for the Product.

Duration of Warranty

This warranty is effective for a period of one (1) year after delivery of Products to the first end user. Notwithstanding the foregoing, asserting a claim under this warranty must be brought within three (3) years after the date of delivery to the initial buyer if not sold initially to the first end user.

ANY IMPLIED WARRANTIES NOT NEGATED HEREBY WHICH MAY ARISE BY OPERATION OF LAW, INCLUDING THE IMPLIED WARRANTIES OF MERCHANTABILITY AND FITNESS FOR A PARTICULAR PURPOSE AND ANY EXPRESS WARRANTIES NOT NEGATED HEREBY, ARE GIVEN SOLELY TO THE INITIAL BUYER AND ARE LIMITED IN DURATION TO ONE (1) YEAR FROM THE DATE OF SHIPMENT BY THE SELLER.

Exclusive Remedy

THE EXCLUSIVE REMEDY UNDER THIS WARRANTY, UNDER ANY EXPRESS WARRANTY OR UNDER ANY IMPLIED WARRANTIES NOT NEGATED HEREBY (INCLUDING THE IMPLIED WARRANTIES OF MERCHANTABILITY AND FITNESS FOR A PARTICULAR PURPOSE), IS **REPLACEMENT**; PROVIDED: (a) THE CLAIMED DEFECT IS

REPORTED TO THE SELLER IN WRITING WITHIN THE WARRANTY PERIOD, INCLUDING A DETAILED WRITTEN DESCRIPTION OF THE CLAIMED DEFECT AND HOW AND WHEN THE CLAIMED DEFECTIVE PRODUCT WAS USED; AND (b) THE CLAIMED DEFECTIVE PRODUCT AND A COPY OF THE PURCHASE INVOICE IS RETURNED TO THE SELLER, FREIGHT AND TRANSPORTATION COSTS PREPAID, UNDER A RETURN MATERIAL AUTHORIZATION AND TRACKING NUMBER ISSUED BY THE SELLER. ALL LABOR COSTS, SHIPPING COSTS, AND TRANSPORTATION COSTS ASSOCIATED WITH THE RETURN OR REPLACEMENT OF THE CLAIMED DEFECTIVE PRODUCT ARE SOLELY THE RESPONSIBILITY OF BUYER OR THE FIRST END USER. THE SELLER RESERVES THE RIGHT TO INSPECT ON THE FIRST END USER'S SITE ANY PRODUCTS CLAIMED TO BE DEFECTIVE BEFORE ISSUING A RETURN MATERIAL AUTHORIZATION. SHOULD SUCH INSPECTION REVEAL, IN THE SELLER'S REASONABLE DISCRETION, THAT THE CLAIMED DEFECT IS NOT COVERED BY THIS WARRANTY, THE PARTY ASSERTING THIS WARRANTY SHALL PAY THE SELLER FOR THE TIME AND EXPENSES RELATED TO SUCH ON-SITE INSPECTION.

Exclusion of Consequential and Incidental Damages

IT IS SPECIFICALLY ACKNOWLEDGED THAT THIS WARRANTY, ANY OTHER EXPRESS WARRANTY NOT NEGATED HEREBY, AND ANY IMPLIED WARRANTY NOT NEGATED HEREBY, INCLUDING THE IMPLIED WARRANTIES OF MERCHANTABILITY AND FITNESS FOR A PARTICULAR PURPOSE, DO NOT COVER, AND NEITHER TLV, TII NOR ITS TLV GROUP COMPANIES WILL IN ANY EVENT BE LIABLE FOR, INCIDENTAL OR CONSEQUENTIAL DAMAGES, INCLUDING, BUT NOT LIMITED TO LOST PROFITS, THE COST OF DISASSEMBLY AND SHIPMENT OF THE DEFECTIVE PRODUCT, INJURY TO OTHER PROPERTY, DAMAGE TO BUYER'S OR THE FIRST END USER'S PRODUCT, DAMAGE TO BUYER'S OR THE FIRST END USER'S PROCESSES, LOSS OF USE, OR OTHER COMMERCIAL LOSSES. WHERE, DUE TO OPERATION OF LAW, CONSEQUENTIAL AND INCIDENTAL DAMAGES UNDER THIS WARRANTY, UNDER ANY OTHER EXPRESS WARRANTY NOT NEGATED HEREBY OR UNDER ANY IMPLIED WARRANTY NOT NEGATED HEREBY (INCLUDING THE IMPLIED WARRANTIES OF MERCHANTABILITY AND FITNESS FOR A PARTICULAR PURPOSE) CANNOT BE EXCLUDED, SUCH DAMAGES ARE EXPRESSLY LIMITED IN AMOUNT TO THE PURCHASE PRICE OF THE DEFECTIVE PRODUCT. THIS EXCLUSION OF CONSEQUENTIAL AND INCIDENTAL DAMAGES, AND THE PROVISION OF THIS WARRANTY LIMITING REMEDIES HEREUNDER TO REPLACEMENT, ARE INDEPENDENT PROVISIONS, AND ANY DETERMINATION THAT THE LIMITATION OF REMEDIES FAILS OF ITS ESSENTIAL PURPOSE OR ANY OTHER DETERMINATION THAT EITHER OF THE ABOVE REMEDIES IS UNENFORCEABLE, SHALL NOT BE CONSTRUED TO MAKE THE OTHER PROVISIONS UNENFORCEABLE.

Exclusion of Other Warranties

THIS WARRANTY IS IN LIEU OF ALL OTHER WARRANTIES, EXPRESS OR IMPLIED, AND ALL OTHER WARRANTIES, INCLUDING BUT NOT LIMITED TO THE IMPLIED WARRANTIES OF MERCHANTABILITY AND FITNESS FOR A PARTICULAR PURPOSE, ARE EXPRESSLY DISCLAIMED.

Severability

Any provision of this warranty which is invalid, prohibited or unenforceable in any jurisdiction shall, as to such jurisdiction, be ineffective to the extent of such invalidity, prohibition or unenforceability without invalidating the remaining provisions hereof, and any such invalidity, prohibition or unenforceability in any such jurisdiction shall not invalidate or render unenforceable such provision in any other jurisdiction.

Service

For Service or Technical Assistance: Contact your TLV representative or your regional TLV office.

In Europe:

TLV EURO ENGINEERING GmbH

Daimler-Benz-Straße 16-18, 74915 Waibstadt, **Germany**

Tel: [49]-(0)7263-9150-0

TLV EURO ENGINEERING UK LTD.

Units 7 & 8, Furlong Business Park, Bishops Cleeve,
Gloucestershire GL52 8TW, **U.K.**

Tel: [44]-(0)1242-227223

TLV EURO ENGINEERING FRANCE SARL

Parc d'Ariane 2, bât. C, 290 rue Ferdinand Perrier, 69800 Saint
Priest, **France**

Tel: [33]-(0)4-72482222

Fax: [33]-(0)4-72482220

In North America:

TLV CORPORATION

13901 South Lakes Drive, Charlotte, NC 28273-6790, **U.S.A.**

Tel: [1]-704-597-9070

Fax: [1]-704-583-1610

TLV ENGINEERING S. A. DE C.V.

Av. Jesús del Monte 39-B-1001, Col. Hda. de las Palmas,
Huixquilucan, Edo. de México, 52763, **Mexico**

Tel: [52]-55-5359-7949

Fax: [52]-55-5359-7585

In Oceania:

TLV PTY LIMITED

Unit 8, 137-145 Rooks Road, Nunawading, Victoria 3131,
Australia

Tel: [61]-(0)3-9873 5610

Fax: [61]-(0)3-9873 5010

In East Asia:

TLV PTE LTD

36 Kaki Bukit Place, #02-01/02, **Singapore** 416214

Tel: [65]-6747 4600

Fax: [65]-6742 0345

TLV SHANGHAI CO., LTD.

5/F, Building 7, No.103 Caobao Road, Xuhui District, Shanghai,
China 200233

Tel: [86]-(0)21-6482-8622

Fax: [86]-(0)21-6482-8623

TLV ENGINEERING SDN. BHD.

No.16, Jalan MJ14, Taman Industri Meranti Jaya, 47120
Puchong, Selangor, **Malaysia**

Tel: [60]-3-8052-2928

Fax: [60]-3-8051-0899

TLV PRIVATE LIMITED

252/94 (K-L) 17th Floor, Muang Thai-Phatra Complex Tower B,
Rachadaphisek Road, Huaykwang, Bangkok 10310, **Thailand**

Tel: [66]-2-693-3799

Fax: [66]-2-693-3979

TLV INC.

#302-1 Bundang Technopark B, 723 Pangyo-ro, Bundang,
Seongnam, Gyeonggi, 13511, **Korea**

Tel: [82]-(0)31-726-2105

Fax: [82]-(0)31-726-2195

In the Middle East:

TLV ENGINEERING FZCO

Building 9W, B163, PO Box 371684, Dubai Airport Free Zone,
Dubai, **UAE**

Email: sales-me@tlv.co.jp

In Other Countries:

TLV INTERNATIONAL, INC.

881 Nagasuna, Noguchi, Kakogawa, Hyogo 675-8511, **Japan**

Tel: [81]-(0)79-427-1818

Fax: [81]-(0)79-425-1167

Manufacturer:

TLV CO., LTD.

881 Nagasuna, Noguchi, Kakogawa, Hyogo 675-8511, **Japan**

Tel: [81]-(0)79-427-1800

Fax: [81]-(0)79-422-2277