



AIR & DRAIN TRAPS

**JA·JAHR Series / G8
TATSU2
SS1VA / JAHRA Series**



TLV® Free Float Technology

AIR TRAPS

For Air

In today's world of automation, compressed air is used in many different industries including high-precision machinery and instrumentation. After air is compressed it is cooled by an after-cooler or in a receiver tank, where condensate is formed from the air as water droplets. This condensate also occurs in compressed air distribution piping, leading to rust and fluctuation in high-precision machinery, as well as causing a reduction in product quality. Air traps protect your equipment and products by discharging condensate automatically.

■ Long Service Life

The hinge-less lever-less free float has one moving part allowing for simple operation. With infinite sealing surfaces, the free float does not suffer from concentrated wear, maintaining initial performance quality over a long time period.

JA•JAHR Series/G8

■ Continuous Condensate Discharge

The float adjusts quickly to changes in condensate flow adjusting the valve seat opening, ensuring continuous rapid discharge without condensate backup.

JA•JAHR Series/G8

■ Rubber Valve Seat for Tight Sealing

The standardized rubber valve seat allows for tight sealing with the precision ground float.

JA Series*/G8

* JA7.2, JA7.5, JA8 and JAHR Series equip fluorine resin valve seat.

■ Valve Seat Cleaning Mechanism

Equipped with an external plunger unit, blockage caused by oils and/or scale can be easily eliminated.

JA Series (JA3D/JA3/JA5/JA7)

■ Discharge High-Viscosity Condensate

With a large ($\frac{5}{8}$ ") orifice, unique intermittent discharge and self-cleaning function, high-viscosity condensate as well as condensate containing dirt/scale can be discharged. Discharges large amounts of condensate (up to approx. 16,000 lbs/hour).

TATSU2

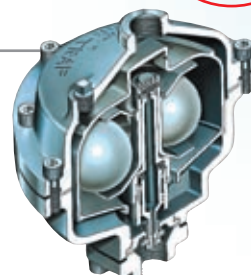
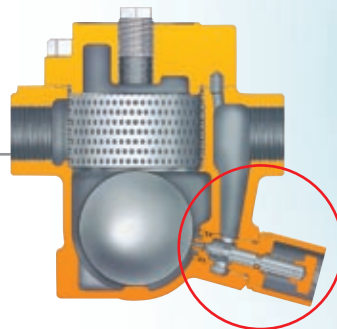

for the Highest Reliability

DRAIN TRAPS

For Air and Inert Gases*

Like compressed air, after air or other inert gases are compressed they are cooled, and condensate is formed from air or the gas as water droplets. Condensate is the cause of many challenges resulting in rust and freezing in the pipes as well as a reduction in product quality. Drain traps for discharging condensate from both compressed air and inert gases protect your equipment and products by discharging condensate automatically as it forms while maintaining a tight seal. These traps are made with durable steel construction for a long service life.

* Do not use with toxic, flammable or otherwise hazardous gases.

Long Service Life

The hinge-less lever-less free float has one moving part allowing for simple operation. With infinite sealing surfaces, the free float does not suffer from concentrated wear, maintaining initial performance quality over a long time period.

SS1VA Series/JAHRA Series

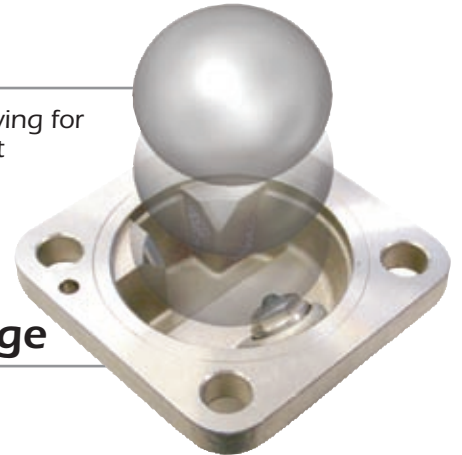

Continuous Condensate Discharge

The float adjusts quickly to changes in condensate flow adjusting the valve seat opening, ensuring continuous rapid discharge without condensate backup.

SS1VA Series/JAHRA Series

Three Point Seating for Tight Sealing

The high-precision ground float fits securely on the three-point seating creating a high-quality seal even for metal valve seats comparable to that of rubber.

SS1VA Series/JAHRA Series

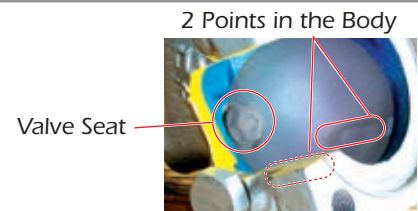

Materials for High-Temperature/Pressure

For higher temperature and pressure applications, TLV Drain Traps offer choices in body and valve seat material to meet specific needs. The SS1VA has all-stainless steel construction with a metal valve seat available for high-temperature applications. The JAHRA Series features cast steel bodies for high-pressure applications with tight-sealing provided by a rubber valve seat.

SS1VA Series/JAHRA Series



JA·JAHR Series /G8

AIR TRAPS

Sample Application: Air Main Drip

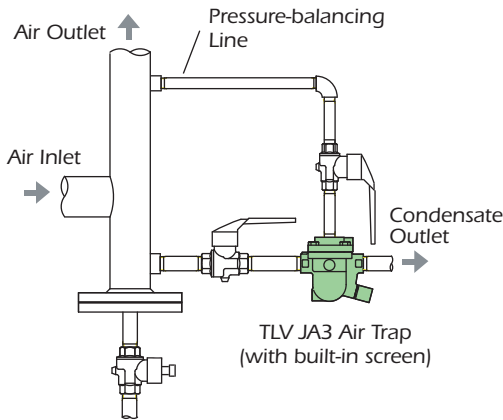

Benefits:

- Free float type for continuous condensate discharge.
- Only one moving part, the free float, simplifies operation and provides reliable service.
- Usable for installation in both horizontal and vertical piping (JA3D).
- External valve seat cleaning mechanism easily eliminates blockage (JA3D/JA series).
- Large orifice to reduce valve seat blockage (JA7/G8).
- Large capacity (Max. 57400 lb/h) and/or high pressure (PMO 600 psig).

Applications:

- Discharge of condensate in air lines (end of piping after receiver tanks, after coolers, etc.).
- Small compressed air lines (JA3D/JA3).
- Lubricated air compressor systems where small amounts of oil get into the condensate (JA7/G8).



JA3D

Valve-seat Cleaning



JA5

Valve-seat Cleaning



JAH8R



G8

Operation

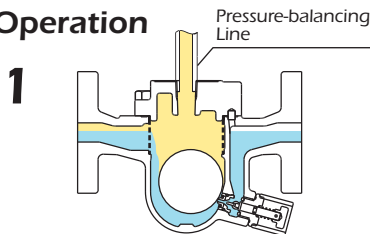

1 As condensate enters the trap, the float rises controlling the size of the valve seat opening. With the valve open, the condensate is continuously discharged.

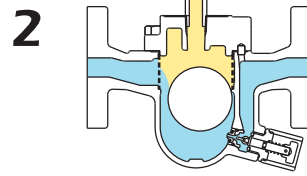

2 If a large condensate load enters the trap at once, the float rises to open the valve seat fully, increasing the condensate discharge capacity.

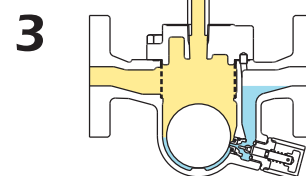

3 If no condensate enters the trap, the float is fully lowered to close the valve seat. The water level remains above the valve seat, promoting tight sealing.

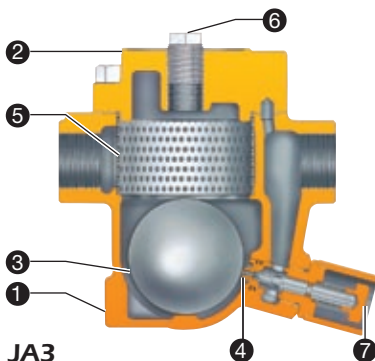

JA3

No.	Part Name
①	Body
②	Cover
③	Float
④	Valve Seat
⑤	Screen
⑥	Balancing Plug
⑦	Plunger

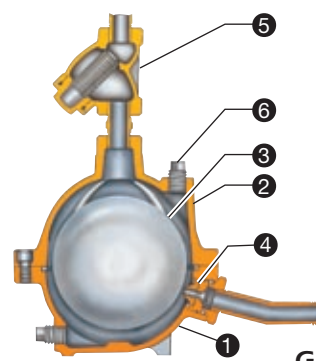

G8

No.	Part Name
①	Body
②	Cover
③	Float
④	Valve Seat
⑤	Strainer
⑥	Balancing Plug

Model	JA3D	JA3	JA5	JAF5	JA7	JA7.2	JA7.5	JA8	G8	JAH7.2R	JAH7.5R	JAH8R
Body Material ¹⁾	ZA	DCI	DCI	DCI	CI	CI	CI	CI	CI	CS	CS	CS
Valve Seat Material ²⁾	NBR	NBR	NBR	NBR	NBR	PTFE	PTFE	PTFE	NBR	PTFE	PTFE	PTFE
Connection ³⁾	S	S	S	F	F	F	F	F	S	SW, F	SW, F	SW, F
Max. Operating Pressure (psig)	230	230	230	230	230	230	230	230	230	600	600	600
Max. Operating Temperature (°F)	212	212	212	212	212	302	302	302	212	302	302	302
Min. Condensate Load for Tight Sealing (lb/h)	—	—	—	—	—	22	22	44 ⁴⁾ , 33	—	22	22	44 ⁴⁾ , 33

¹⁾ ZA: Zinc Alloy, DCI: Ductile Cast Iron, CI: Cast Iron, CS: Cast Steel ²⁾ NBR: Nitrile Rubber, PTFE: Fluorine Resin

³⁾ S = Screwed, F = Flanged, SW = Socket Weld ⁴⁾ Orifice No. 2 & 5

Sample Application: Receiver Tank

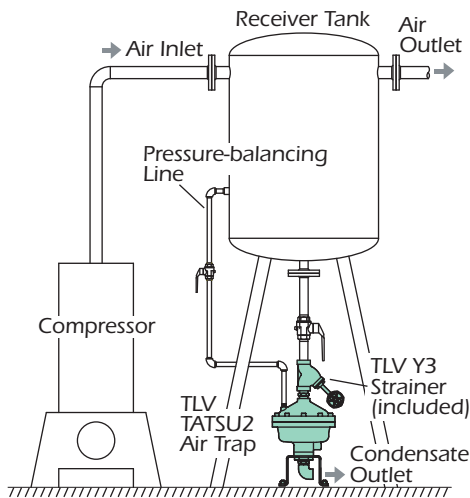

Benefits:

- Large ($\frac{5}{8}$ " diameter) valve seat for easy discharge of oil, rust and scale.
- Large condensate discharge capacity (approx. 16,000 lbs/hour).
- Automatic self-cleaning function during operation keeps the valve seat free of any blockage.

Applications:

- Air piping containing oil, rust or scale.
- Air-using receiver tanks or other equipment with higher viscosity condensate.



TATSU2



Operation

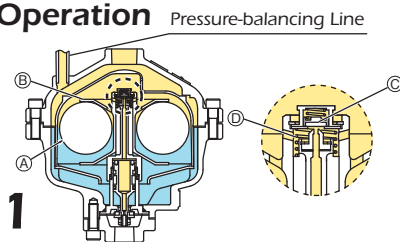

Condensate and oil flow into the trap and accumulate. When the level in the trap body rises to a point where the floats **A** rise and lift the float holder **B**, the pilot valve **C** opens with the help of the coil spring **D**.

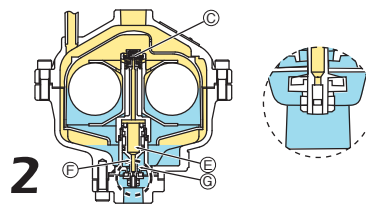

When pilot valve **C** opens, secondary pressure air enters the pressure chamber **E** lowering the piston **F** and opening the main valve **G** to discharge condensate.

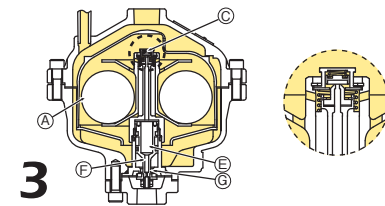

While the condensate inside the float cover discharges, the floats **A** fall and cause the pilot valve **C** to close. The pressure in the pressure chamber **E** is released to the outlet and the piston **F** rises to close the main valve **G** after a slight delay to allow the main valve to self-clean during discharge.

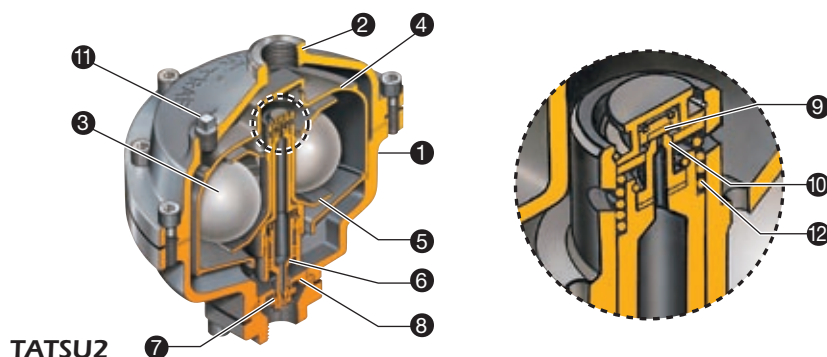

TATSU2

Note: Y Strainer with Blowdown Valve Included

No.	Part Name
①	Body
②	Cover
③	Float
④	Float Cover
⑤	Float Holder
⑥	Piston
⑦	Main Valve
⑧	Main Valve Seat
⑨	Pilot Valve
⑩	Pilot Valve Seat
⑪	Balancing Plug
⑫	Opening Spring

Model	TATSU2
Body Material	Cast Iron
Connection	Screwed
Max. Operating Pressure (psig)	150
Min. Operating Pressure (psig)	30
Max. Operating Temperature (°F)	176

Sample Application: Receiver Tank

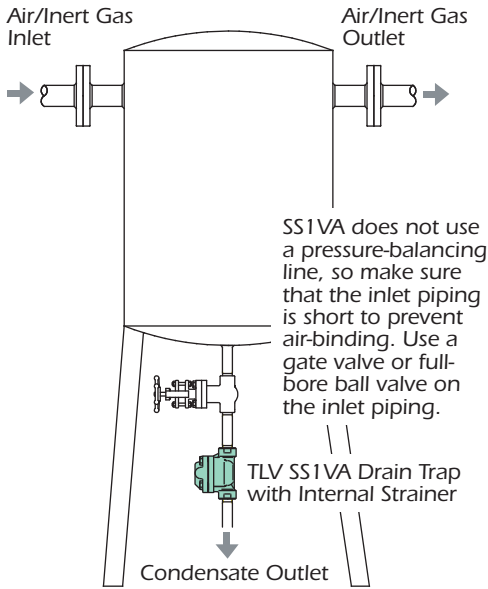

Benefits:

- High-precision ground free float with three-point seating technology for tight sealing even during low-load conditions.
- Only one moving part, the free float, simplifies operation and provides reliable service.
- All-stainless steel body with long life for vertical installation.
- Small models allow installation even with limited space.

Applications*:

- Discharge of condensate from compressed air or inert gas-using equipment (compressors, etc.)
- Discharge of condensate in compressed air or inert gas lines (end of piping after receiver tanks, aftercoolers, etc.).
- Small capacity compressed air or inert gas lines.

* Do not use for toxic, flammable or otherwise hazardous gases.



SS1VA



Operation

1

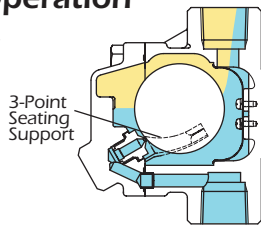

As condensate enters the trap, the float rises controlling the size of the valve seat opening. With the valve open, the condensate is continuously discharged.

2

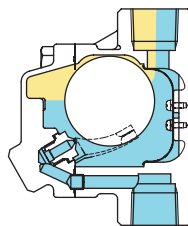

If a large condensate load enters the trap at once, the float rises to open the valve seat fully, increasing the condensate discharge capacity.

3

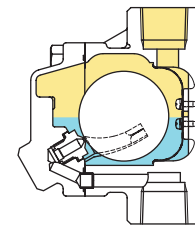

If no condensate enters the trap, the float is fully lowered to close the valve seat. The water level remains above the valve seat, promoting tight sealing.

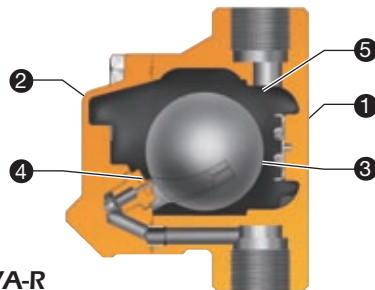

SS1VA-R

	Part Name
①	Body
②	Cover
③	Float
④	Orifice (Valve Seat)
⑤	Screen

Model	SS1VA-R	SS1VA-M		
Body Material	Cast Stainless Steel	Cast Stainless Steel		
Valve Seat Material	Nitrile Rubber	Metal		
Connection	Screwed	Screwed		
Max. Operating Pressure (psig)	150	300		
Max. Operating Temperature (°F)	212	428		
Maximum Seat Leakage (Minimum ΔP Required for Rating (psi))	<0.01% of rated valve capacity (0.1)	<0.15 standard ml/min*, <1 bubble/min (1.5)	<0.1% of rated valve capacity (0.1)	<0.1% of rated valve capacity (1.5)

Sample Application:

Main Line with Separator

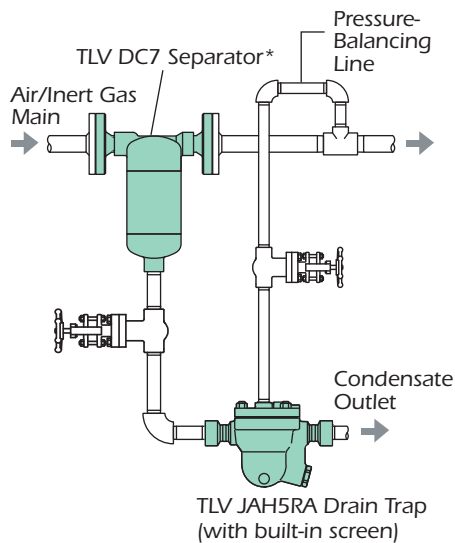

Benefits:

- High-precision ground free float with three-point seating technology for tight sealing even during low-load conditions.
- Only one moving part, the free float, simplifies operation and provides reliable service.
- Durable pressure-resistant design.
- Small model allows installation even with limited space (JAH5RA).

Applications*:

- Discharge of condensate from compressed air or inert gas-using equipment (compressors, etc.)
- Discharge of condensate in compressed air or inert gas lines (end of piping after receiver tanks, aftercoolers, etc.)
- Large capacity compressed air or inert gas lines.

* Do not use for toxic, flammable or otherwise hazardous gases.



JAH5RA

Three-Point Seating

For High-pressures

Operation

1

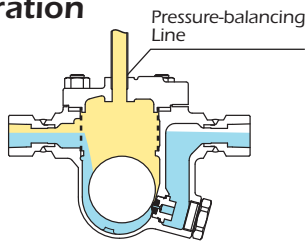

As condensate enters the trap, the float rises controlling the size of the valve seat opening. With the valve open, the condensate is continuously discharged.

2

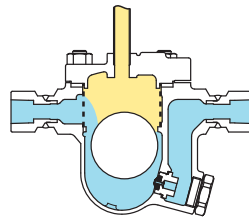

If a large condensate load enters the trap at once, the float rises to open the valve seat fully, increasing the condensate discharge capacity.

3

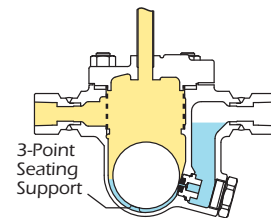

If no condensate enters the trap, the float is fully lowered to close the valve seat. The water level remains above the valve seat, promoting tight sealing.

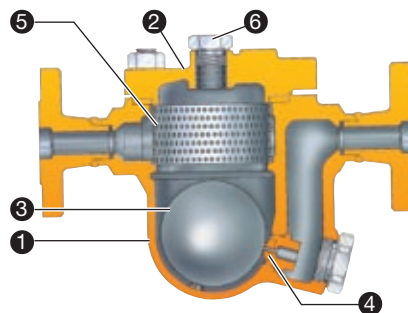

JAH5RA

No.	Part Name
①	Body
②	Cover
③	Float
④	Orifice (Valve Seat)
⑤	Screen
⑥	Balancing Plug

Model	JAH5RA-R	JAH7RA-R		
Body Material	Cast Steel	Cast Steel		
Valve Seat Material	Nitrile Rubber	Nitrile Rubber		
Connection	Screwed, Socket Weld, Flanged	Screwed, Socket Weld, Flanged		
Max. Operating Pressure (psig)	315	600		
Max. Operating Temperature (°F)	212	212		
Maximum Seat Leakage (Minimum ΔP Required for Rating (psi))	<0.01% of rated valve capacity (0.1)	<0.15 standard ml/min*, <1 bubble/min (1.5)	<0.1% of rated valve capacity (0.1)	<0.1% of rated valve capacity (1.5)

* Standard milliliters based on 60 °F, 14.73 psi abs

Pressure-balancing Line

Without a pressure-balancing line connected between the trap cover and a dry portion of the piping/receiver tank, air or gas binding can occur. Air or gas binding occurs when vapor in the trap cavity cannot be displaced by the incoming condensate, which prevents condensate from being discharged.

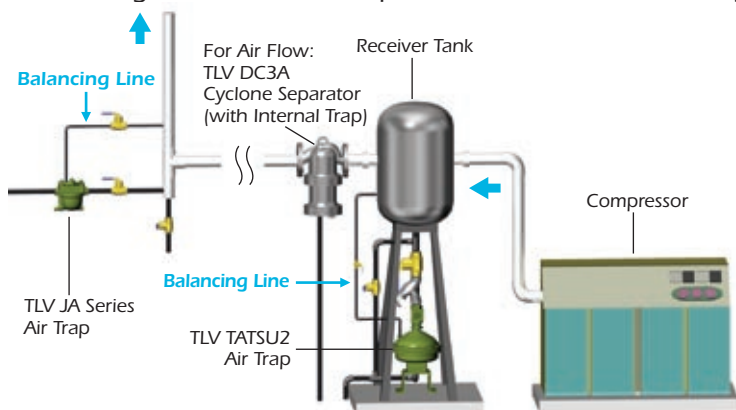

Note: Since the SS1VA is installed vertically, a balancing line is not generally required. However, to prevent air binding, use as short as possible straight and vertical inlet piping with a minimum nominal diameter of 1/2".

Selection Guide

Applicable Fluids	Model	Connection	Body Material	Piping Direction	Valve Seat Material	Operating Press. Range (psig)	Max. Oper. Temp. (°F)	Maximum Seat Leakage ¹⁾	Max. Discharge Capacity (lb/h)	Min. Specific Gravity ²⁾	Special Feature					
Air Traps	Air	Screwed	JA3D	Horiz./Vert.	Nitrile Rubber	Vacuum - 230	212	—	505	1.0	Plunger for manual valve cleaning					
			JA3						605							
			JA5						995							
			JAF5													
			JAF7						3540							
		Screwed	G8	Cast Iron	Vertical	Nitrile Rubber	Vacuum - 230	212	—		2950	Simple direct passages				
			JA7.2								Flanged		PTFE	302	Min. Cond. Load for Tight Sealing (lb/h)	20980
																41400
		JAF7.5	Cast Steel	Horizontal	PTFE	302	Min. Cond. Load for Tight Sealing (lb/h)	57400								
		JAF8						20980								
		Flanged	JAH7.2R	Cast Steel	Horizontal	PTFE	Vacuum - 600	302	—		41400	Increased capacity and high pressure service				
			JAH7.5R								57400					
JAH8R	Screwed	Cast Iron	Vertical	Nitrile Rubber	30 - 150	176	—	16280	Discharges High-Viscosity Condensate							
TATSUZ2																
Drain Traps	Air and Inert Gases ⁴⁾	Screwed	Cast Stainless Steel	Vertical	Nitrile Rubber	Vacuum - 150	212	<0.01% RVC ⁵⁾ (<0.15 st. ml/min ⁶⁾ , <1 bubble/min)	285	0.50	All parts are stainless steel					
									SS1VA-M			Metal	Vacuum - 300	428	<0.1% RVC ⁵⁾ (<0.1% RVC ⁵⁾)	845
		Screwed, Socket Weld, Flanged	Cast Steel	Horizontal	Nitrile Rubber	Vacuum - 315	212	<0.01% RVC ⁵⁾ (<0.15 st. ml/min ⁶⁾ , <1 bubble/min)	595		High pressure service					
									JAH7RA-R			Vacuum - 600	<0.01% RVC ⁵⁾ (<0.15 st. ml/min ⁶⁾ , <1 bubble/min)	3035		

¹⁾ Rating is equivalent for differential pressures of 0.1 psi (1.5 psi) and higher

²⁾ Maximum operating pressure, maximum differential pressure and condensate discharge capacity are affected by the specific gravity of the condensate.

³⁾ Orifice No. 2 & 5 ⁴⁾ Do not use with toxic, flammable or otherwise hazardous gases. ⁵⁾ RVC = rated valve capacity ⁶⁾ Standard milliliters based on 60 °F, 14.73 psi abs Full product details (sizes, pressures, capacities and materials) are included in the individual specification data sheets (SDS).



To avoid abnormal operation, accidents or serious injury, DO NOT use this product outside of the specification range. Local regulations may restrict the use of this product to below the conditions quoted.



DO NOT DISASSEMBLE OR REMOVE THIS PRODUCT WHILE IT IS UNDER PRESSURE. Allow internal pressure of this product to equal atmospheric pressure and its surface to cool to room temperature before disassembling or removing. Failure to do so could cause burns or other injury. READ INSTRUCTION MANUAL CAREFULLY.

TLV CORPORATION

13901 South Lakes Drive, Charlotte, NC 28273-6790

Tel: 704-597-9070 Fax: 704-583-1610

E-mail: tlv@tlvengineering.com <https://www.tlv.com>

For Technical Service 1-800 "TLV TRAP"



Manufacturer
TLV CO., LTD.
Kakogawa, Japan
is approved by LRQA Ltd. to ISO 9001/14001

