

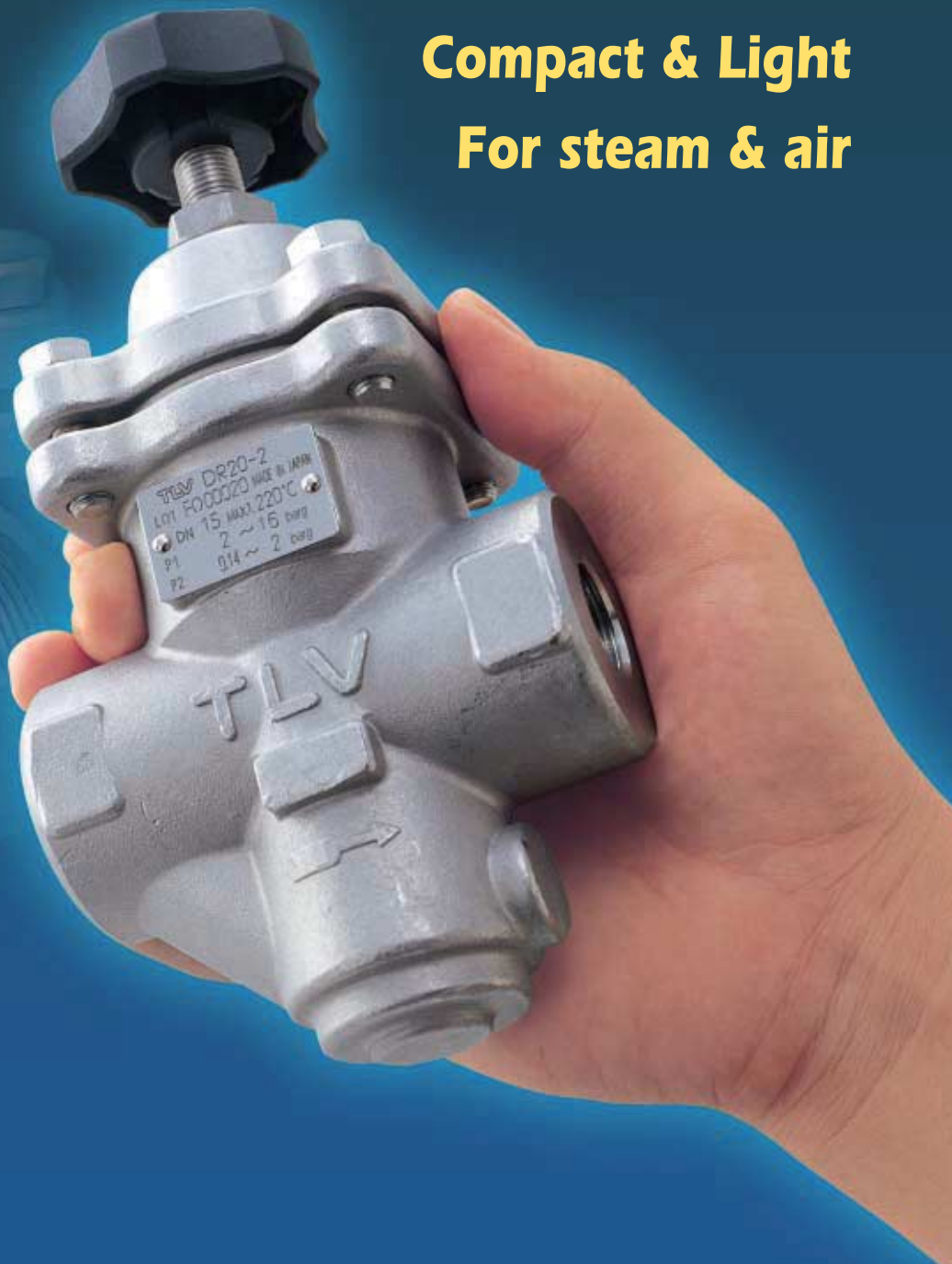

# **DIRECT-ACTING PRESSURE REDUCING VALVE**

**DR20  
PN-DR**

**Manual or Pneumatic Setting**  
**Stainless steel construction**  
**Pressure reduction ratio of 30:1**  
**Compact & Light**  
**For steam & air**



TLV DR20-2  
LOT F0000020 MADE IN JAPAN  
DN 15 MAX 220°C  
P1 2 ~ 15 barg  
P2 0.14 ~ 2 barg

TLV



# More stable secondary pressure than with conventional direct-acting reducing valves!

## Features

### Manual or Pneumatic Setting

The DR20 offers manually-set pressure reduction in an extremely compact body. With all the benefits of the DR20, the PN-DR's pneumatic setting function enables remote adjustment of secondary pressure, while the manual setting ensures minimum acceptable set pressure in the event of motive air failure.

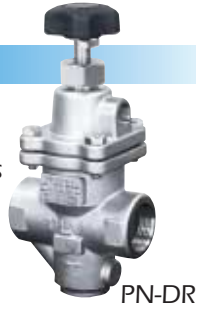

### Stainless Steel Construction

The body is constructed of stainless steel to prevent the problems caused by rust and the resultant build-up of scale.

### Pressure Reduction Ratio of 30:1

A single DR20/PN-DR is capable of reduction to minute pressures normally requiring 2-stage pressure reduction.

### Superior Flow Characteristics

A more stable secondary pressure than with conventional direct-acting reducing valves is maintained through the use of a flat valve.



### Fine Pressures Adjustment

For manual setting, the easy to grip handle, which fits comfortably in the hand, and a small-pitch adjusting screw make it possible to make extremely small adjustments in the secondary pressure. The locknut prevents accidental adjustment.

### Easy Maintenance

Maintenance and disassembly can be performed with readily available tools. The built-in screen ensures extended trouble-free operation. All gaskets are made of PTFE and are reusable.

## Construction

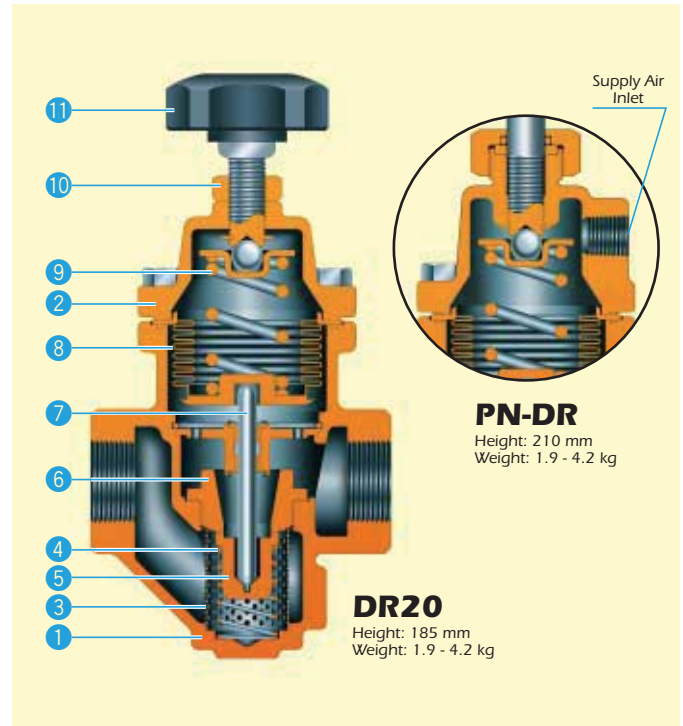

No.	Description	Material	No.	Description	Material
1	Body	Cast Stainless Steel	6	Valve Seat	Stainless Steel
2			Cover	Cast Stainless Steel	7
3	Screen	Stainless Steel	8	Bellows	Stainless Steel
4			Coil Spring	Stainless Steel	9
5	Coil Spring	Stainless Steel	10	Locknut	Stainless Steel
	Main Valve	Stainless Steel	11	Adjustment Handle	Stainless Steel/Plastic

## Specifications

Model	DR20-2	DR20-6	DR20-10	PN-DR-2	PN-DR-6
Setting Method	Manual			Manual/Pneumatic	
Connection	Screwed, Flanged				
Size	1/2", 3/4", 1" / DN 15, 20, 25				
Max. Operating Pressure (barg) PMO	16				
Max. Operating Temperature (°C) TMO	220				
Primary Pressure Range (barg)	2 - 16		6 - 16	2 - 16	
Adjustable Pressure Range (barg)	0.14 - 2, but not less than 1/30 of primary pressure	1.8 - 6	5.4 - 10	0.14 - 2, but not less than 1/30 of primary pressure	1.8 - 6
	Secondary pressure must not exceed 90% of primary pressure				
Motive Medium	—			Oil-free air, filtered to 5 µm	
Air Supply Pressure Range (barg)	—			0 - 10	
Applicable Fluids*	Steam, Air**			Steam, Air	

\*Do not use for toxic, flammable, or otherwise hazardous fluids.

\*\*Optional A-DR20 with soft seat (fluorine rubber) for improved sealing is available for air applications.

(Restrictions: PMO / Max. Primary Pressure: 10 barg, Max. Adjustable Pressure: 9 barg, TMO: 100 °C). See A-DR20 data sheet for details.

PRESSURE SHELL DESIGN CONDITIONS (**NOT** OPERATING CONDITIONS): Maximum Allowable Pressure (barg) PMA: 20

Maximum Allowable Temperature (°C) TMA: 220

1 bar = 0.1 MPa



To avoid abnormal operation, accidents of serious injury, DO NOT use this product outside of the specification range. Local regulations may restrict the use of this product to below the conditions quoted.

For installation in horizontal piping (with adjustment handle facing up)

## TLV EURO ENGINEERING UK LTD.

Units 7 & 8, Furlong Business Park, Bishops Cleeve, Gloucestershire GL52 8TW, UK

Tel: [44]-(0)1242-227223

Fax: [44]-(0)1242-223077

E-mail: info@tlv.co.uk

http://www.tlv.com

Manufacturer  
**TLV CO., LTD.**  
Kagogawa, Japan  
is approved by LRQA Ltd. to ISO 9001/14001

