



BELLOWS SEALED VALVE

MODEL BE1L

FORGED STEEL BELLOWS-SEALED GLOBE VALVE

Features

Compact forged steel globe valve for steam and hot water. Suitable for use with small-process equipment.

1. Maintenance-free globe valve with bellows sealed stem.
2. No-leak gland with triple seals: bellows, gland packing and stem seal at full-open position.
3. No need to tighten or replace gland packing.
4. Good seal with stellite hardened surfaces on valve plug and valve seat.
5. Smooth handwheel operation.
6. Compact forged steel body.



Do not use for toxic, flammable or otherwise hazardous fluids.

Specifications

Model	BE1L	
Connection	Socket Welded	Flanged
Size (mm)	15, 20, 25, 40, 50	
Maximum Operating Pressure (MPaG) PMO	5.0	2.1
Maximum Operating Temperature (°C) TMO	425	

PRESSURE SHELL DESIGN CONDITIONS (**NOT** OPERATING CONDITIONS): Maximum Allowable Pressure PMA (MPaG): 5.0 1 MPa = 10.197 kg/cm²
Maximum Allowable Temperature TMA (°C): 425

No.	Description	Material	JIS	ASTM/AISI
①	Body	Carbon Steel	—	A105
②	Bonnet	Carbon Steel	—	A105
③	Valve Stem	Stainless Steel	—	A276-410
④	Valve Plug*	Stainless Steel	—	A276-304
⑤	Valve Seat (Body)*	Carbon Steel	—	A105
⑥	Bellows Ring	Stainless Steel	—	A276-316L
⑦	Bellows	Stainless Steel	SUS316L	AISI316L**
⑧	Bellows Flange	Stainless Steel	—	A276-316L
⑨	Lower Bonnet Gasket	Graphite/Stainless Steel	- /SUS316	- /AISI316**
⑩	Upper Bonnet Gasket	Graphite	—	—
⑪	Bonnet Bolt	Alloy Steel	—	A193-B7
⑫	Pin	Stainless Steel	—	A276-410
⑬	Gland Packing	Graphite	—	—
⑭	Gland Bushing	Stainless Steel	—	A276-410
⑮	Gland Flange	Carbon Steel	—	A105
⑯	Eye Bolt	Alloy Steel	—	A193-B7
⑰	Eye Bolt Nut	Carbon Steel	—	A194-2H
⑱	Eye Bolt Pin	Carbon Steel	S25C	AISI1025**
⑲	Yoke Sleeve	Stainless Steel	—	A276-410
⑳	Washer	Stainless Steel	—	A276-304
㉑	Handwheel	Malleable Cast Iron	FCMB270	A47 Gr.32510
㉒	Nameplate	Aluminium	AIP	B209
㉓	Lock Nut	Carbon Steel	S25C	AISI1025**
㉔	Flange	Carbon Steel	—	A105

* Stellite hardened surfaces on Valve Plug and Valve Seat ** Equivalent

CAUTION To avoid abnormal operation, accidents or serious injury, DO NOT use this product outside of the specification range. Local regulations may restrict the use of this

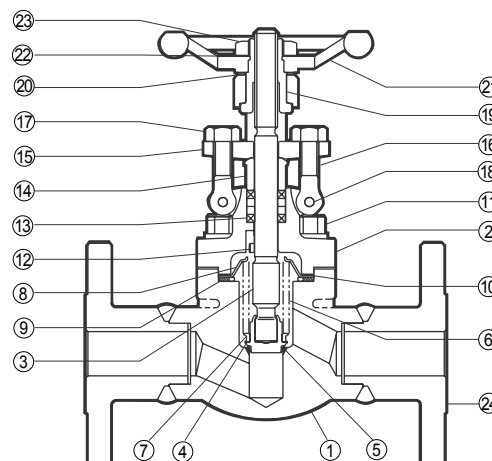

Dimensions

● **BE1L Socket Welded**

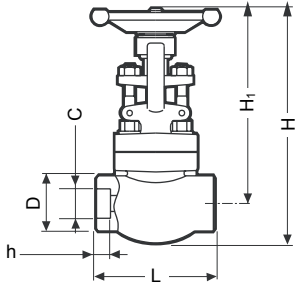

BE1L Socket Welded* (mm)

Size	L	H**	H1**	D	C	h	Weight (kg)
15	79	185	160	32	22.2	11	2.3
20	92	193	165	38	27.7	12.7	2.6
25	111	227	190	47	34.5		4.4
40	152	296	236	62	49.1		7.9
50	172	335	269	74	61.1	16	12

* JIS standard. ASME B16.11-2005 available ** At full open position

● **BE1L Flanged**

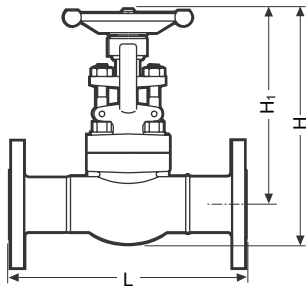

BE1L Flanged* (mm)

Size	L		H**	H1**	Weight*** (kg)
	ASME Class				
	150RF	300RF			
15	152	152	185	160	3.8
20	178	178	193	165	5.3
25	203	203	227	190	7.7
40	229	229	296	236	14
50	267	267	335	269	20

* JIS 10KRF, 20KRF also available ** At full open position
*** Weight is for Class 300 RF

Cv Values

	Nominal Valve Size (mm)				
	15	20	25	40	50
Cv (US)	2.3	2.9	5.3	14	20
Cv (UK)	1.9	2.4	4.4	12	17
Kvs (DIN)	2.0	2.5	4.5	12	17

Note: BE1L is a reduced port valve

ISO 9001/ISO 14001

TLV® CO., LTD.
Kakogawa, Japan
is approved by LRQA Ltd. to ISO 9001/14001

