



BELLOWS SEALED VALVE

MODEL BE3L FORGED STEEL

GLOBE-TYPE VALVE WITH BELLOWS SEALED STEM

Features

Compact forged steel globe valve for steam, water and air.

Suitable for use with small-process equipment.

1. Maintenance-free globe valve with bellows sealed stem.
2. No-leak gland with triple seals: bellows, gland packing and stem seal at full-open position.
3. No need to tighten or replace gland packing.
4. Good seal with stellite hardened surfaces on valve plug and valve seat.
5. Smooth handwheel operation.
6. Durable stainless steel bellows tested to withstand 10 000 cycles.
7. Compact forged steel body.



Specifications

Model	BE3L	
Connection	Screwed	Socket Welded
Size	1/2", 3/4", 1", 1 1/2", 2"	DN 15, 20, 25, 40, 50
Maximum Operating Pressure (barg) PMO	50	
Maximum Operating Temperature (°C) TMO	400	
Applicable fluid*	Steam, water, air	

* Do not use for toxic, flammable or otherwise hazardous fluids.

1 bar = 0.1 MPa

PRESSURE SHELL DESIGN CONDITIONS (**NOT** OPERATING CONDITIONS): Maximum Allowable Pressure (barg) PMA: 57
Maximum Allowable Temperature (°C) TMA: 427



To avoid abnormal operation, accidents or serious injury, DO NOT use this product outside of the specification range. Local regulations may restrict the use of this product to below the conditions quoted.

No.	Description	Material	DIN*	ASTM/AISI
①	Body	Carbon Steel	1.0460	A105
②	Bonnet	Carbon Steel	1.0460	A105
③	Gland Flange	Carbon Steel	1.0460	A105
④	Valve Plug	Stainless Steel	1.4006	A276 Type 410
⑤	Bellows	Stainless Steel	1.4541	A479 Type 321
⑥	Lower Bonnet Gasket	Stainl. Stl. / Graphite	1.4404	AISI316
⑦	Upper Bonnet Gasket	Graphite	—	—
⑧	Bonnet Bolt	Alloy Steel	1.7225	A193 Gr.B7
⑨	Gland Nut	Carbon Steel	—	A194 Gr.2H
⑩	Gland Bolt	Stainless Steel	1.4006	AISI410
⑪	Gland Packing	Graphite	—	—
⑫	Gland Bushing	Stainless Steel	1.4006	A276 Type 410
⑬	Handwheel	Carbon Steel	1.0460	A105
⑭	Lock Nut	Carbon Steel	1.0460	A105
⑮	Nameplate	Aluminum	—	B209
⑯	Valve Stem	Stainless Steel	1.4006	A276 Type 410
⑰	Stem Nut	Stainless Steel	1.4401	A582 Type 416

* Equivalent materials

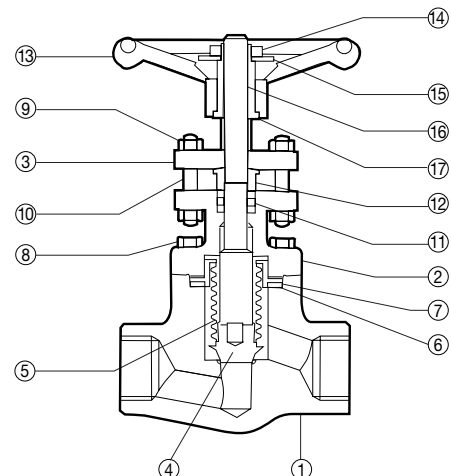

Copyright © TLV

Dimensions

● **BE3L Screwed**

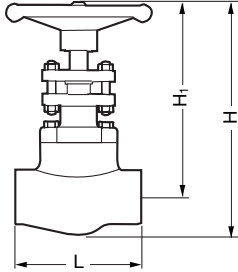

BE3L Screwed* (mm)

Size	L	H**	H ₁ **	Weight (kg)
1/2"	80	155	136	1.7
3/4"	90	165	144	2.3
1"	110	190	167	3.6
1 1/2"	155	260	220	7.5
2"	170	280	230	12

* BSP DIN 2999, other standards available

** At full open position

● **BE3L Socket Welded**

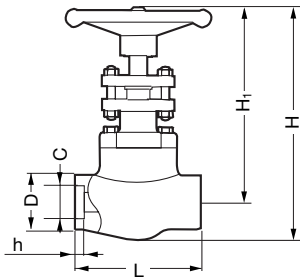

BE3L Socket Welded* (mm)

DN	L	H**	H ₁ **	φD	φC	h	Weight (kg)
15	80	155	136	32	21.8	12	1,7
20	90	165	144	38	27.2	14	2,3
25	110	190	167	48	33.9	16	3,6
40	155	260	220	65	48.8	19	7,5
50	170	280	230	78	61.2	22	12

* ASME B16.11-2005, other standards available

** At full open position

Cv & Kvs Values

	Nominal Valve Size (mm)				
	15	20	25	40	50
Kvs (DIN)	1.4	2.7	4.3	12	21
Cv (UK)	1.4	2.6	4.2	12	20
Cv (US)	1.6	3.2	5.0	14	24

Note: BE3L is a reduced port valve

ISO 9001/ISO 14001

TLV® CO., LTD.
Kakogawa, Japan
is approved by LRQA Ltd. to ISO 9001/14001

