



PowerTrap®

MODEL GP10

MECHANICAL PUMP FOR CONDENSATE REMOVAL AND RECOVERY

Features

Pump for a wide range of applications. Ideal for condensate removal from vented receivers and sump drainage.

1. Handles high-temperature condensate without cavitation.
2. No electric power or additional level controls required, hence INTRINSICALLY SAFE.
3. Pump will operate with a low filling head.
4. Durable nickel-based alloy compression coil spring.
5. Easy, inline access to internal parts simplifies cleaning and reduces maintenance costs.
6. High-quality stainless steel internals and hardened working surfaces ensure reliability.
7. Cycle Counter installable as option.



Specifications

Model		GP10		
Body Material		Cast Iron	Cast Steel	
Connection	Pumped Medium Inlet & Outlet	Screwed	Screwed	Flanged
	Motive Medium & Pump Exhaust	Screwed	Screwed	Flanged
Size (mm)	Pumped Medium Inlet x Outlet	80 x 50		50 x 50, 80 x 50
	Motive Medium Inlet	25		
	Pump Exhaust Outlet	25		
Maximum Operating Pressure (MPaG)	PMO	1.05		
Maximum Operating Temperature (°C)	TMO	185		
Motive Medium Pressure Range (MPaG)		0.03 - 1.05		
Maximum Allowable Back Pressure		0.05 MPa less than motive medium pressure used		
Volume of Each Discharge Cycle (ℓ)		approximately 30		
Motive Medium*		Saturated Steam, Compressed Air, Nitrogen		
Pumped Medium**		Steam Condensate, Water		

* Do not use with toxic, flammable or otherwise hazardous fluids.

1 MPa = 10.197 kg/cm²

** Do not use for fluids with specific gravities under 0.85 or over 1, or for toxic, flammable or otherwise hazardous fluids.

PRESSURE SHELL DESIGN CONDITIONS (**NOT** OPERATING CONDITIONS): Maximum Allowable Pressure (MPaG) PMA: 1.4 (Cast Iron), 1.6 (Cast Steel)
Maximum Allowable Temperature (°C) TMA: 220



To avoid abnormal operation, accidents or serious injury, DO NOT use this product outside of the specification range. Local regulations may restrict the use of this product to below the conditions quoted.

No.	Description	Material	JIS	ASTM/AISI*
①	Body	Cast Iron	FC250	A126 Cl.B
		Cast Steel**	—	A216 Gr.WCB
②	Cover	Cast Iron	FC250	A126 Cl.B
		Cast Steel**	—	A216 Gr.WCB
③	Cover Gasket	Graphite Compound	—	—
④	Float	Stainless Steel	SUS316L/303	AISI316L/303
⑤	Lever Unit	Stainless Steel	—	—
⑥	Snap-action Unit	Stainless Steel	—	—
⑦	Motive Medium Intake Valve Unit	Intake Valve	SUS303/440C	AISI303/440C
		Valve Seat	Cast Stainless Steel/ Stainless Steel	— / SUS440C
⑧	Exhaust Valve Unit	Exhaust Valve	SUS303/440C	AISI303/440C
		Valve Seat	SUS420F	AISI420F
⑨	Check Valve***	CK3MG	—	A351 Gr.CF8
		CKF3MG	Cast Stainless Steel	—

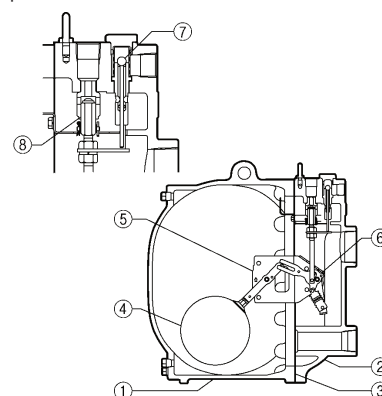

* Equivalent ** Option: Cast Stainless Steel

*** Not shown, model depends on GP10 connection: CK3MG for screwed, CKF3MG for flanged

Discharge Capacity

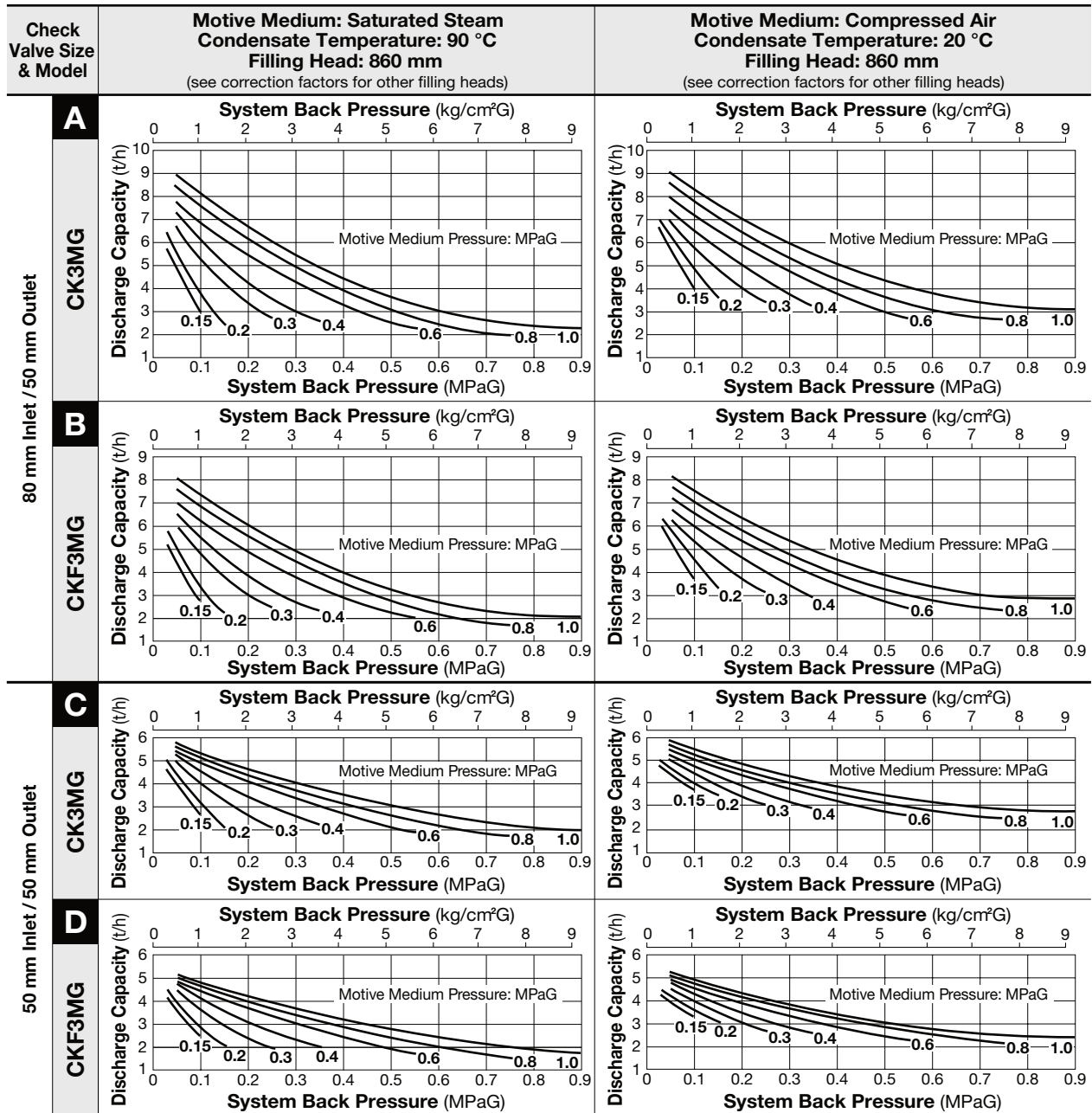

● **Correction Factors** (for filling heads other than 860 mm)

For Discharge Capacity Graphs **A & B**

(minimum filling head: 710 mm)

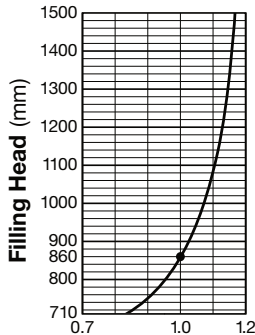

For Discharge Capacity Graphs **C & D**

(minimum filling head: 710 mm)

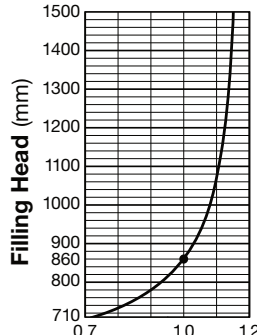

NOTE:

- A check valve must be installed at both the pumped medium inlet and outlet. To achieve the above capacities with the standard GP10 configuration, TLV CK3MG or CKF3MG check valves must be used.
- Motive medium pressure minus back pressure must be greater than 0.05 MPa.
- In closed system applications, the motive medium must be compatible with the liquid being pumped. If a non-condensable gas such as air or nitrogen is used as the motive medium, consult TLV for assistance.
- A strainer must be installed at the motive medium and pumped medium inlets

● **Illustration of Filling Head and Pressure**

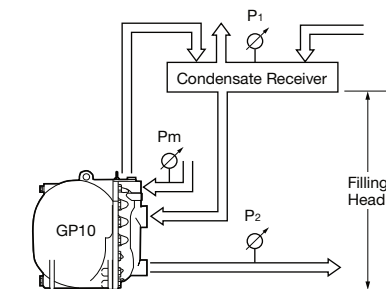

The discharge capacity is determined by the motive medium, motive medium pressure (P_m) and back pressure (P₂).
Make sure that:
Discharge Capacity × Correction Factor > Required Flow Rate

Dimensions

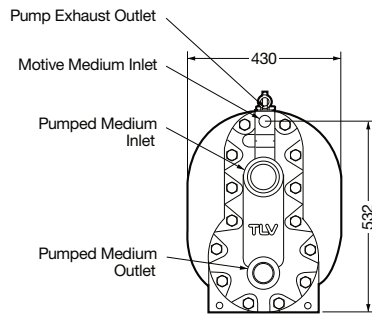

● Screwed*

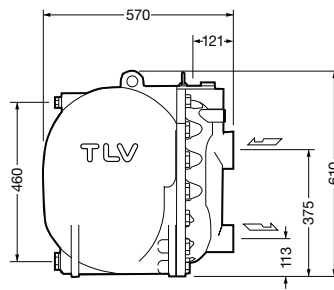

● Flanged**

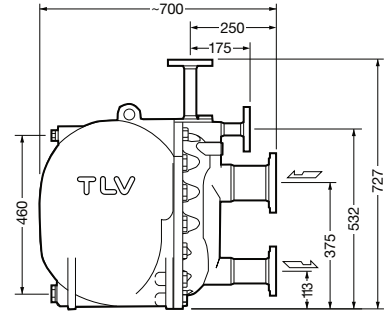

Units: mm

Weight (kg): 124 (Cast Iron), 136 (Cast Steel)
* Rc(PT), other standards available

Weight (kg): 146 (Cast Steel)
** ASME Class 150 RF, other standards available

Size of Receiver/Reservoir

The receiver/reservoir must have a capacity sufficient to store the condensate produced during the **PowerTrap** operation and discharge. A receiver will generally be larger than a reservoir because it must handle the condensate both as a liquid and as flash steam, and separate one from the other so that only condensate is sent to the **PowerTrap**.

1. Size of Receiver (flash steam is involved) (Length: 1 m)

Flash Steam up to (kg/h)	Receiver Diameter mm (in)	Vent Pipe Diameter mm (in)
25	80 (3)	25 (1)
50	100 (4)	50 (2)
75	125 (5)	50 (2)
100	150 (6)	80 (3)
150	200 (8)	80 (3)
200	200 (8)	100 (4)
300	250 (10)	125 (5)
400	300 (12)	125 (5)
500	350 (14)	150 (6)
700	400 (16)	200 (8)
800	450 (18)	200 (8)
1000	500 (20)	200 (8)
1100	500 (20)	250 (10)
1400	550 (22)	250 (10)
1500	600 (24)	250 (10)

2. Size of Reservoir (flash steam is not involved)

Amount of Condensate (kg/h)	Reservoir Diameter (mm) and Length (m)						
	40	50	80	100	150	200	250
300 or less	1.2 m	0.7					
400	1.5	1.0					
500	2.0	1.2	0.5				
600		1.5	0.6				
800		2.0	0.8	0.5			
1000			1.0	0.7			
1500			1.5	1.0			
2000			2.0	1.3	0.6		
3000				2.0	0.9	0.5	
4000					1.2	0.7	
5000					1.4	0.8	0.5
6000					1.7	1.0	0.6
7000					2.0	1.2	0.7
8000						1.3	0.8
9000						1.5	0.9
10000						1.7	1.0

Reservoir length can be reduced by 50% when the motive medium pressure (P_m) divided by back pressure (P₂) equals 2 or greater (when P_m ÷ P₂ ≥ 2).

3. If flash steam is condensed before it enters the receiver/reservoir, compare tables 1. and 2. and choose the larger of the two resultant sizes.

Steam or Air Consumption (Motive Medium)

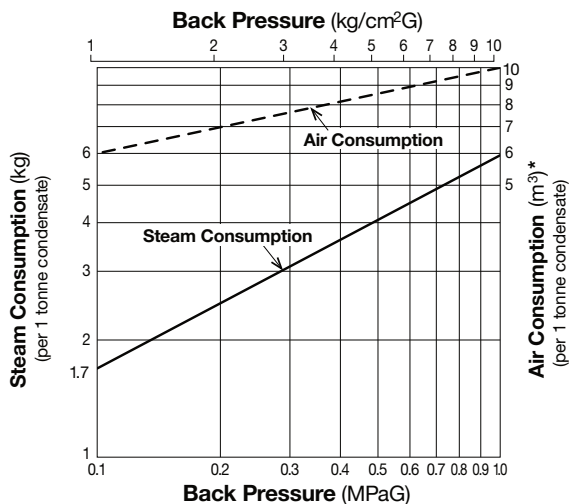

* Equivalent consumption of air at 20 °C under atmospheric pressure

Cycle Counter (option)

Two types of counter can be installed on the GP10 to monitor the number of pumping cycles and help to determine the timing of maintenance, or estimate the volume of pumped condensate.

- C1CM – (Counter Unit Type):
Self-contained standalone unit. Includes an LCD counter display and an operation indicator LED.
- C1SM – (Terminal Box Type):
Designed for use with remote monitoring equipment and systems.

Intrinsically safe models are also available.
See the Cycle Counter SDS for further details.

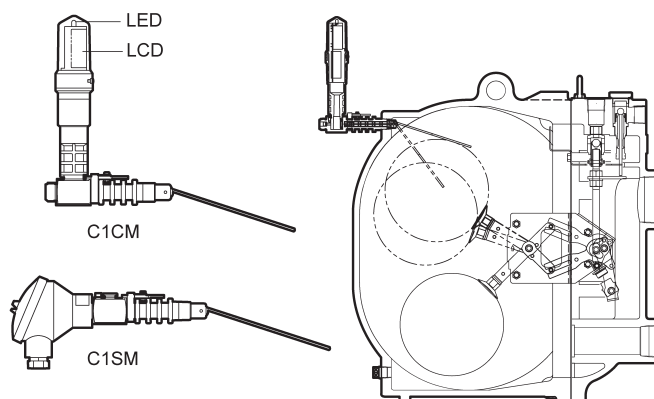

Manufacturer

TLV CO., LTD.
Kakogawa, Japan

is approved by LRQA Ltd. to ISO 9001/14001

ISO 9001
ISO 14001

