



PowerTrap®

MODEL GP10L

COMPACT MECHANICAL PUMP FOR CONDENSATE REMOVAL AND RECOVERY

Features

Pump for a wide range of applications. Ideal for low flow condensate removal from vented receivers situated at a low level.

1. Handles high-temperature condensate without cavitation.
2. No electric power or additional level controls required, hence **INTRINSICALLY SAFE**.
3. Pump will operate with a low filling head (min. 300 mm).
4. Easy, inline access to internal parts simplifies cleaning and reduces maintenance costs.
5. High-quality stainless steel internals and hardened working surfaces ensure reliability.
6. Compact design permits installation in a limited space.
7. Cycle counter installable as option.

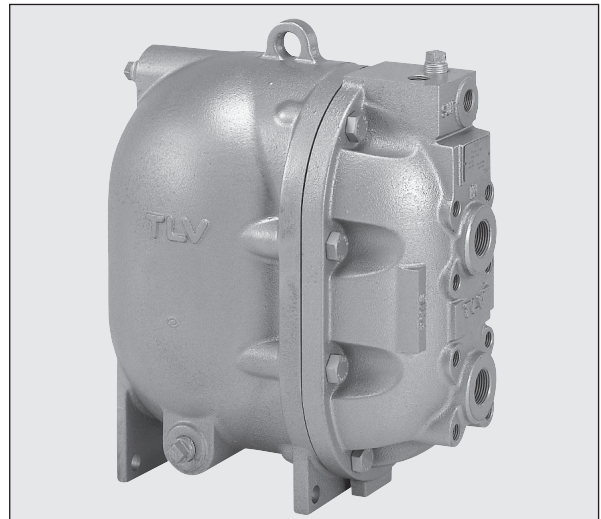

Specifications

Model		GP10L	
Connection	Pumped Medium Inlet & Outlet	Screwed and Flanged*	Screwed
	Motive Medium & Pump Exhaust	Screwed	
Size (mm)	Pumped Medium: Inlet x Outlet	25 x 25	40 x 25
	Motive Medium Inlet	15	
	Pump Exhaust Outlet	15	
Maximum Operating Pressure (MPaG)	PMO	1.05	
Maximum Operating Temperature (°C)	TMO	185	
Motive Medium Pressure Range (MPaG)	0.03 to 1.05		
Maximum Allowable Back Pressure	0.05 MPa less than motive medium pressure used		
Volume of Each Discharge Cycle (ℓ)	Approx. 6.0		
Motive Medium**	Saturated Steam, Compressed Air, Nitrogen		
Pumped Medium***	Steam Condensate, Water		

* For details of flange connection, see picture at bottom right. ** Do not use with toxic, flammable or otherwise hazardous fluids. 1 MPa = 10.197 kg/cm²
 *** Do not use for fluids with specific gravities under 0.85 or over 1, or for toxic, flammable or otherwise hazardous fluids.

PRESSURE SHELL DESIGN CONDITIONS (NOT OPERATING CONDITIONS):

Maximum Allowable Pressure (MPaG) PMA: 1.6 (Cast Iron), 2.1 (Cast Steel)
 Maximum Allowable Temperature (°C) TMA: 220

CAUTION To avoid abnormal operation, accidents or serious injury, DO NOT use this product outside of the specification range. Local regulations may restrict the use of this product to below the conditions quoted.

No.	Description	Material	JIS	ASTM/AISI*
①	Body	Cast Iron	FC250	A126 Cl.B
		Cast Steel**	—	A216 Gr.WCB
②	Cover	Cast Iron	FC250	A126 Cl.B
		Cast Steel**	—	A216 Gr.WCB
③	Cover Gasket	Graphite Compound	—	—
④	Float	Stainless Steel	SUS316L	AISI316L
⑤	Snap-action Unit	Stainless Steel	—	—
⑥	Motive Medium Intake Valve Unit	Inlet Valve	SUS440C	AISI440C
		Valve Seat	SUS420F	AISI420F
⑦	Exhaust Valve Unit	Exhaust Valve	SUS440C	AISI440C
		Valve Seat	SUS420F	AISI420F
⑧	Inlet Check Valve	Screwed	CK3MG***	Cast Stainless Steel
		Flanged	CKF5M	Stainless Steel
⑨	Outlet Check Valve	Screwed	CK3MG***	Cast Stainless Steel
		Flanged	CKF3M	Cast Stainless Steel

* Equivalent ** Option: Cast Stainless Steel *** Not shown

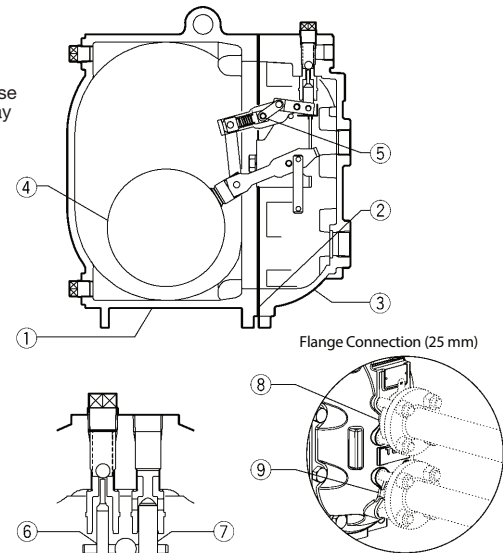

Discharge Capacity

A

Connection:	Screwed
Inlet size:	25 mm
Outlet size:	25 mm
Check Valve:	CK3MG
Inlet:	25 mm
Outlet:	25 mm
Filling Head:	630 mm

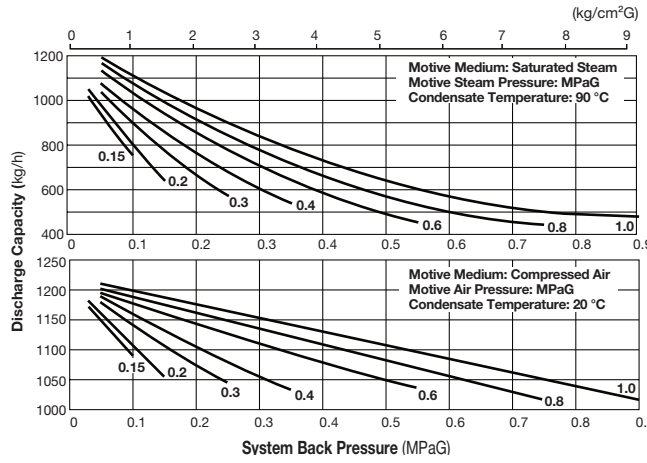

- **Correction Factor**
For discharge capacity graph **A** installed with filling head other than 630 mm (minimum filling head: 450 mm)

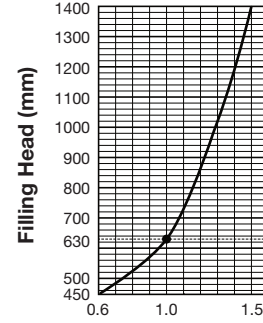

B

Connection:	Screwed
Inlet size:	40 mm
Outlet size:	25 mm
Check Valve:	CK3MG
Inlet:	40 mm
Outlet:	25 mm
Filling Head:	630 mm

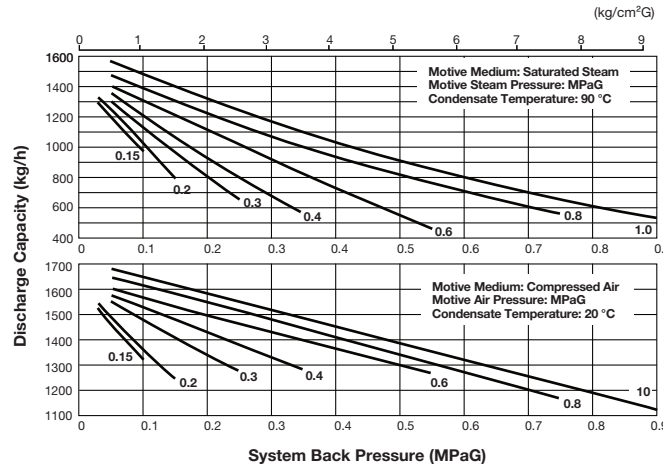

- **Correction Factor**
For discharge capacity graph **B** installed with filling head other than 630 mm (minimum filling head: 450 mm)

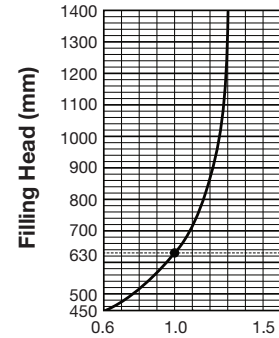

C

Connection:	Flanged
Inlet size:	25 mm
Outlet size:	25 mm
Check Valve:	
Inlet (CKF5M):	25 mm
Outlet (CKF3M):	25 mm
Filling Head:	630 mm

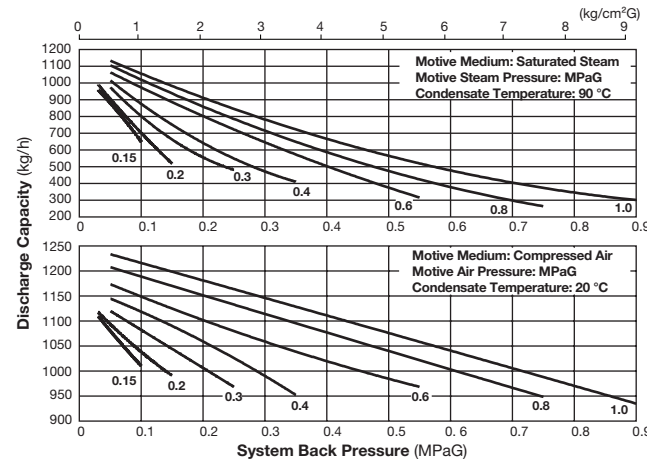

- **Correction Factor**
For discharge capacity graph **C** installed with filling head other than 630 mm (minimum filling head: 400 mm)

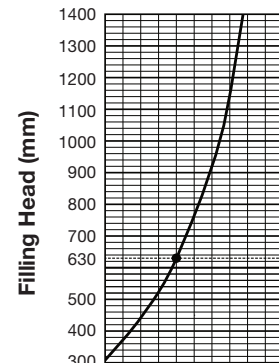

NOTE:

- A check valve must be installed at both the pumped medium inlet and outlet. To achieve the above capacities with the standard GP10L configuration, either TLV check valves CK3MG (inlet & outlet), or CKF5M (inlet) and CKF3M (outlet) must be used depending on connection type.
- Motive steam pressure minus back pressure must be greater than 0.05 MPa.
- In closed system applications, the motive medium must be compatible with the liquid being pumped. If a non-condensable gas such as air or nitrogen is used as the motive medium, consult TLV for assistance.
- A strainer must be installed at the motive medium and pumped medium inlets.

● **Filling Head and Pressures**

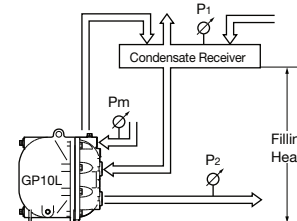

- The discharge capacity is determined by the motive medium, motive medium pressure (Pm) and back pressure (P2).

Make sure that:
Discharge Capacity × Correction Factor > Required Flow Rate

Dimensions

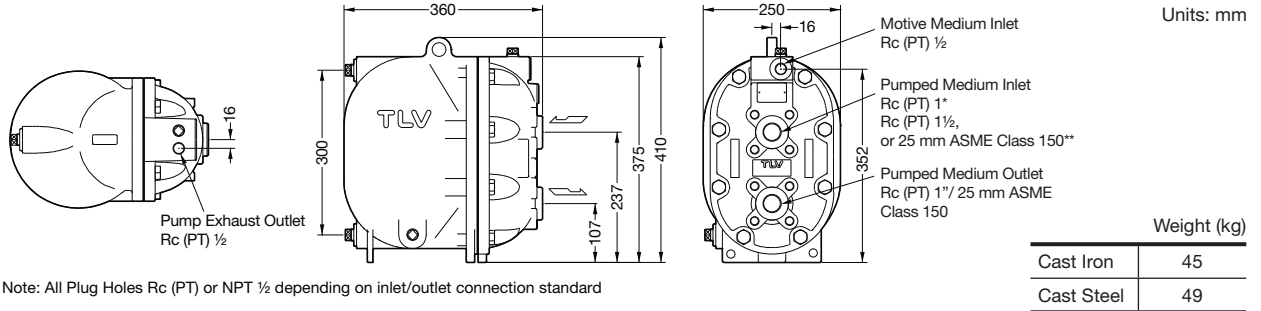

Size of Receiver/Reservoir

The receiver/reservoir must have a capacity sufficient to store the condensate produced during the PowerTrap operation and discharge. A receiver will generally be larger than a reservoir because it must handle the condensate both as a liquid and as flash steam, and separate one from the other so that only condensate is sent to the PowerTrap.

1. Size of Receiver; flash steam is involved (Length: 1 m)

Flash steam up to kg/h	Receiver diameter mm (in)	Vent pipe diameter mm (in)
25	80 (3)	25 (1)
50	100 (4)	50 (2)
75	125 (5)	50 (2)
100	150 (6)	80 (3)
150	200 (8)	80 (3)
200	200 (8)	100 (4)
300	250 (10)	125 (5)
400	300 (12)	125 (5)
500	350 (14)	150 (6)
700	400 (16)	200 (8)
800	450 (18)	200 (8)
1000	500 (20)	200 (8)
1100	500 (20)	250 (10)
1400	550 (22)	250 (10)
1500	600 (24)	250 (10)

2. Size of Reservoir; flash steam is not involved

Amount of Condensate (kg/h)	Reservoir Diameter (mm) and Length (m)						
	40	50	80	100	150	200	250
300 or less	1.2 m	0.7					
400	1.5	1.0					
500	2.0	1.2	0.5				
600		1.5	0.6				
800		2.0	0.8	0.5			
1000			1.0	0.7			
1500			1.5	1.0			
2000			2.0	1.3	0.6		
3000				2.0	0.9	0.5	
4000					1.2	0.7	
5000					1.4	0.8	0.5
6000					1.7	1.0	0.6
7000					2.0	1.2	0.7
8000						1.3	0.8
9000						1.5	0.9
10000						1.7	1.0

Reservoir length can be reduced by 50% when the motive medium pressure (P_m) divided by back pressure (P₂) equals 2 or greater (when P_m ÷ P₂ ≥ 2).

3. If flash steam is condensed before it enters the receiver/reservoir, compare tables 1 and 2 and choose the larger of the two sizes.

Steam or Air Consumption (Motive Medium)

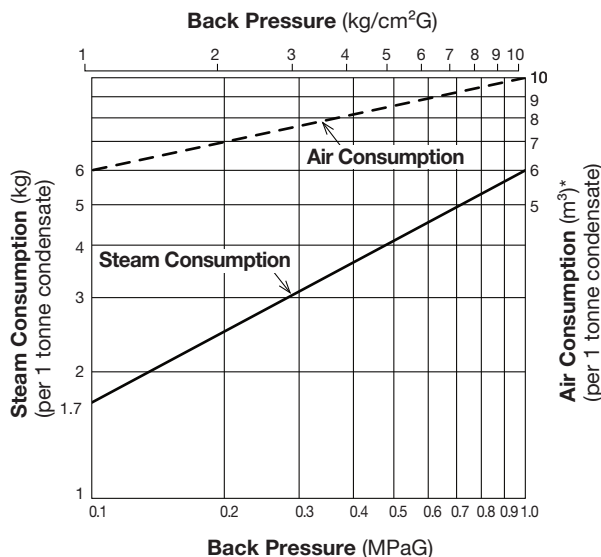

* Equivalent consumption of air at 20 °C under atmospheric pressure

Cycle Counter (Option)

Two types of counter can be installed on GP10L to monitor the number of pumping cycles and help to determine the timing of maintenance, or estimate the volume of pumped condensate.

- C1CM (Counter Unit Type):
Self-contained standalone unit. Includes an LCD counter display and an operation indicator LED.
- C1SM (Terminal Box Type):
Designed for use with remote monitoring equipment and systems.

Intrinsically safe models are also available.
See the Cycle Counter SDS for further details.

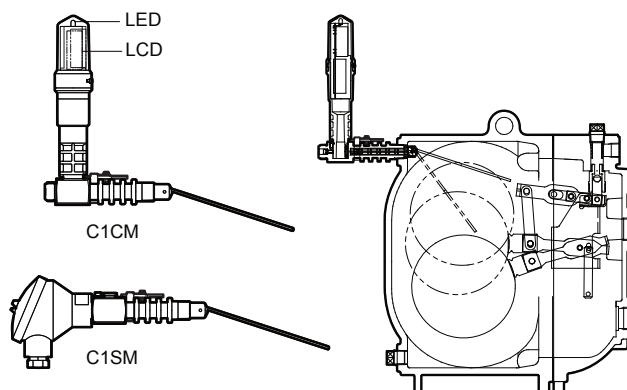

Manufacturer
TLV CO., LTD.
Kakogawa, Japan
is approved by LRQA Ltd. to ISO 9001/14001

