



PowerTrap[®] SYSTEM PACKAGE

MODEL GP14L-1AJ

COMPACT AND READY-TO-CONNECT MECHANICAL PUMP AND TANK PACKAGE

Features

Compact mechanical pump package incorporating a PowerTrap non-electric, mechanical pump for condensate removal and recovery, and pre-assembled with all necessary piping and valves for ease of installation, operation and maintenance.

1. Handles high-temperature condensate without cavitation.
2. No electric power or additional level controls required, hence INTRINSICALLY SAFE.
3. Can be used after connecting a condensate inlet, condensate outlet, motive medium inlet, overflow outlet, and an exhaust connection.
4. Compact design permits installation in a limited space.
5. Cycle Counter installable as option.



Specifications

Model		GP14L-1AJ
Connection (mm)	Condensate Inlet	50 ASME Class 150RF
	Condensate Outlet	25 ASME Class 150RF
	Motive Medium Inlet	15 ASME Class 150RF
	Exhaust	80 ASME Class 150RF
	Overflow Outlet	50 ASME Class 150RF
Maximum Operating Pressure (MPaG)	PMO	PowerTrap Unit: 1.05**
Maximum Operating Temperature (°C)	TMO	PowerTrap Unit: 185
Motive Medium Pressure Range (MPaG)		0.03 to 1.05
Maximum Allowable Back Pressure		0.05 MPa less than motive medium pressure used
Volume of Each Discharge Cycle (ℓ)		Approx. 8.0
Condensate Tank Capacity (ℓ)		20
Maximum Allowable Flash Steam (kg/h)		200
Motive Medium		Saturated Steam, Compressed Air, Nitrogen
Pumped Medium*		Steam Condensate, Water

* Do not use with toxic, flammable or otherwise hazardous fluids.

** The condensate tank unit must be under atmospheric conditions.

Other flanged connections available. Internal connections are JIS.

PRESSURE SHELL DESIGN CONDITIONS (**NOT** OPERATING CONDITIONS): Maximum Allowable Pressure (MPaG) PMA: 1.6 (PowerTrap Unit)
Maximum Allowable Temperature (°C) TMA: 220 (PowerTrap Unit)

1 MPa = 10.197 kg/cm²



To avoid abnormal operation, accidents or serious injury, DO NOT use this product outside of the specification range. Local regulations may restrict the use of this product to below the conditions quoted.

No.	Description	Material	JIS	ASTM/AISI*
①	PowerTrap Unit	Cast Iron	FC250	A126 Cl.B
②	Condensate Tank Unit	Carbon Steel	STPG370	A53 Type S Gr.A
③	Inlet Unit	Carbon Steel	STPG370	A53 Type S Gr.A
④	Motive Medium Inlet	Carbon Steel/ Malleable Cast Iron	STPG370/ FCMB270	A53 Type S Gr.A/ A47 Gr.32510
⑤	Exhaust Pipe Unit	Carbon Steel/ Malleable Cast Iron	STPG370/ FCMB270	A53 Type S Gr.A/ A47 Gr.32510
⑥	Support Set for Motive Medium Inlet Piping	Carbon Steel	SPCC	A109

* Equivalent

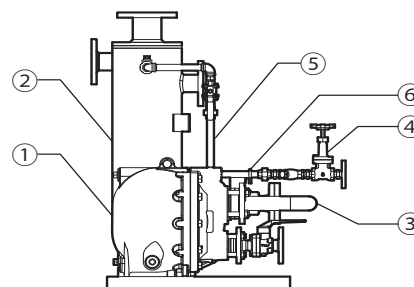

Copyright © TLV

Discharge Capacity

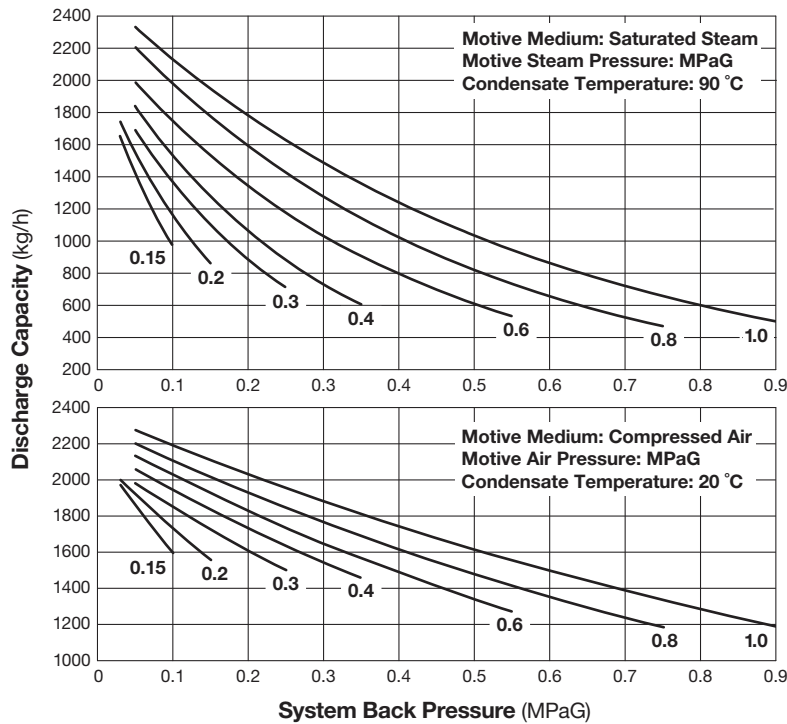

NOTE:

- The discharge capacity is determined by the motive medium, motive medium pressure (P_m) and back pressure (P_2).
 Make sure that: Discharge Capacity > Required Flow Rate
- Motive medium pressure minus back pressure must be greater than 0.05 MPa.
- In closed system applications, the motive medium must be compatible with the liquid being pumped.
 If a non-condensable gas such as air or nitrogen is used as the motive medium, consult TLV for assistance.

Steam or Air Consumption (Motive Medium)

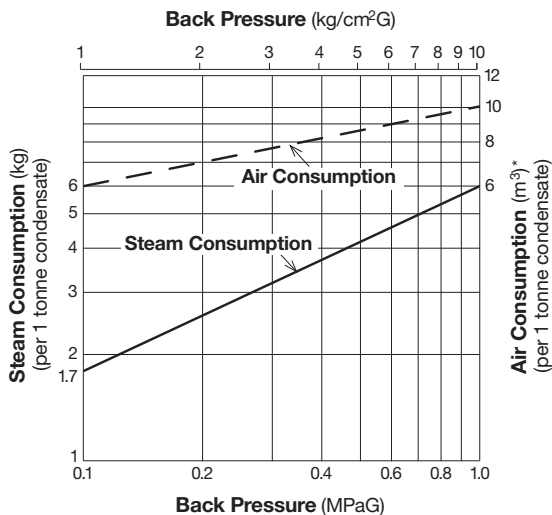

* Equivalent consumption of air at 20 °C under atmospheric pressure

Dimensions

● **GP14L-1AJ** Flanged

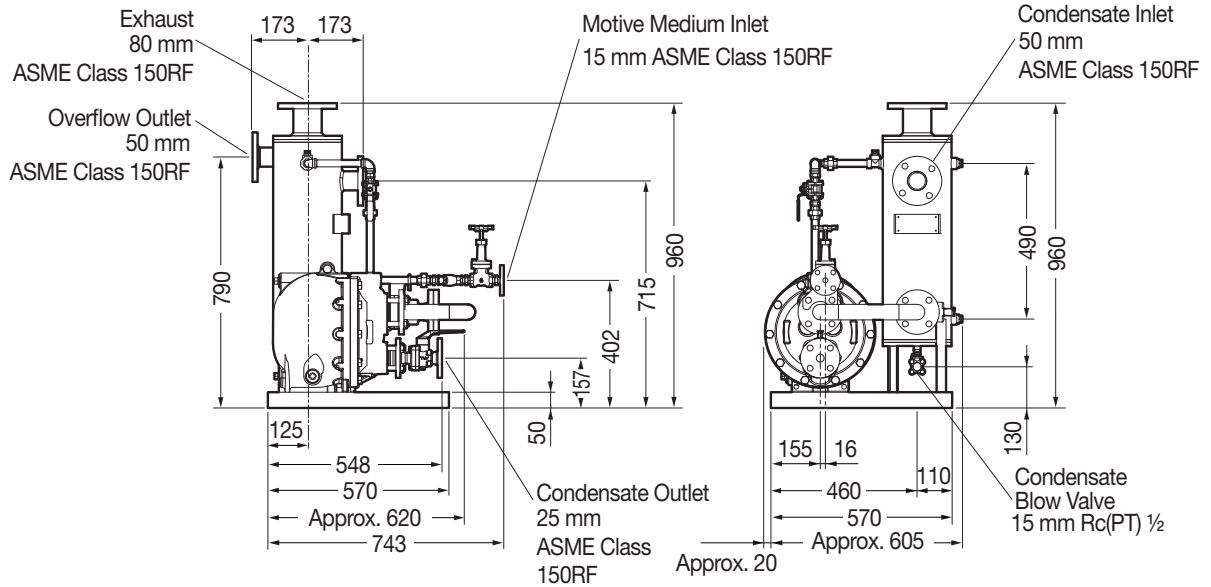

Note: All plug holes Rc(PT) 1/2

Units: mm
Weight: 150 kg

Cycle Counter (Option)

Two types of counter can be installed on the PowerTrap unit to monitor the number of pumping cycles and help to determine the timing of maintenance, or estimate the volume of pumped condensate.

- **C1CM - (Counter Unit Type):**
Self-contained standalone unit. Includes an LCD counter display and an operation indicator LED.
- **C1SM - (Terminal Box Type):**
Designed for use with remote monitoring equipment and systems.

Intrinsically safe models are also available. See the Cycle Counter SDS for further details.

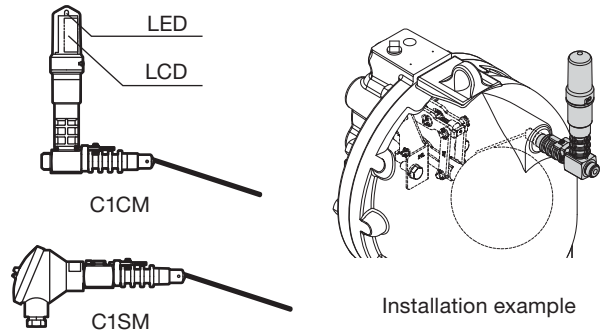

Optional Equipment*

Inlet strainer	50 mm ASME Class 150RF Cast Stainless Steel SCS14A
Motive medium pressure reducing valve	DR20-10** 15 + Pressure gauge + Valve set
Liquid level gauge for tank	Including connection parts
Liquid level gauge for PowerTrap	With siphon pipe and connection parts
Cycle counter for PowerTrap Unit***	See above

Custom specifications and options may also be available. Please contact TLV.
 * Optional equipment should be installed after delivery to avoid damage during transportation.
 ** Refer to the individual specification data sheet (SDS) for full product details.
 *** Pressure gauge and cycle counter cannot be installed on the PowerTrap unit when using the liquid level gauge for PowerTrap.

Memo:

Manufacturer
TLV® **CO., LTD.**
Kakogawa, Japan
is approved by LRQA Ltd. to ISO 9001/14001

