



PowerTrap®

MODEL GT10

MECHANICAL PUMP WITH STEAM TRAP FOR CONDENSATE REMOVAL AND RECOVERY

Features

Pump/Trap with built-in steam trap for a wide range of applications: drainage of heat exchangers, flash steam recovery systems and non-vented receivers such as low-pressure stages of turbines and absorption chillers, often operating under vacuum conditions.

1. Handles high-temperature condensate without cavitation.
2. No electric power or additional level controls required, hence INTRINSICALLY SAFE.
3. Pump will operate with a low filling head.
4. Durable nickel-based alloy compression coil spring.
5. Easy, inline access to internal parts simplifies cleaning and reduces maintenance costs.
6. High-quality stainless steel internals and hardened working surfaces ensure reliability.



Specifications

Model		GT10		
Body Material		Cast Iron	Cast Steel	
Connection	Pumped Medium Inlet & Outlet	Screwed	Screwed	Flanged
	Motive Medium & Pump Exhaust	Screwed	Screwed	Flanged
Size (mm)	Pumped Medium Inlet x Outlet	80 x 50		50 x 50, 80 x 50
	Motive Medium Inlet	25		
	Pump Exhaust Outlet	25		
Maximum Operating Pressure (MPaG)		PMO	1.05	
Maximum Operating Temperature (°C)		TMO	185	
Motive Medium Pressure Range (MPaG)		0.03 - 1.05		
Maximum Allowable Back Pressure		0.05 MPa less than motive medium pressure used		
Volume of Each Discharge Cycle (ℓ)		approximately 30		
Motive Medium*		Saturated Steam		
Pumped Medium**		Steam Condensate		

* Do not use with toxic, flammable or otherwise hazardous fluids.

1 MPa = 10.197 kg/cm²

** Do not use for fluids with specific gravities under 0.85 or over 1, or for toxic, flammable or otherwise hazardous fluids.

PRESSURE SHELL DESIGN CONDITIONS (**NOT** OPERATING CONDITIONS): Maximum Allowable Pressure (MPaG) PMA: 1.4 (Cast Iron), 1.6 (Cast Steel)
Maximum Allowable Temperature (°C) TMA: 220



To avoid abnormal operation, accidents or serious injury, DO NOT use this product outside of the specification range. Local regulations may restrict the use of this product to below the conditions quoted.

No.	Description	Material	JIS	ASTM/AISI*
①	Body	Cast Iron	FC250	A126 Cl.B
		Cast Steel**	—	A216 Gr.WCB
②	Cover	Cast Iron	FC250	A126 Cl.B
		Cast Steel**	—	A216 Gr.WCB
③	Cover Gasket	Graphite Compound	—	—
④	Float	Stainless Steel	SUS316L/303	AISI316L/303
⑤	Lever Unit	Stainless Steel	—	—
⑥	Snap-action Unit	Stainless Steel	—	—
⑦	Motive Medium Intake Valve	Stainless Steel	SUS303/440C	AISI303/440C
	Valve Seat	Cast Stainless Steel/ Stainless Steel	— / SUS440C	A351 Gr.CF8/ AISI440C
⑧	Exhaust Valve Unit	Stainless Steel	SUS303/440C	AISI303/440C
	Valve Seat	Stainless Steel	SUS420F	AISI420F
⑨	Trap Unit	Stainless Steel	—	—
⑩	Check Valve***	CK3MG	Cast Stainless Steel	A351 Gr.CF8
		CKF3MG	Cast Stainless Steel	A351 Gr.CF8

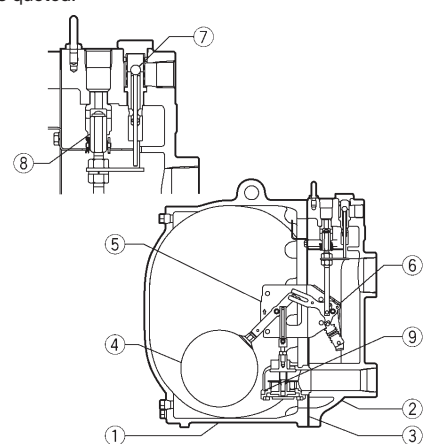

Copyright © TLV

* Equivalent ** Option: Cast Stainless Steel

*** Not shown, model depends on GT10 connection: CK3MG for screwed, CKF3MG for flanged

Discharge Capacity

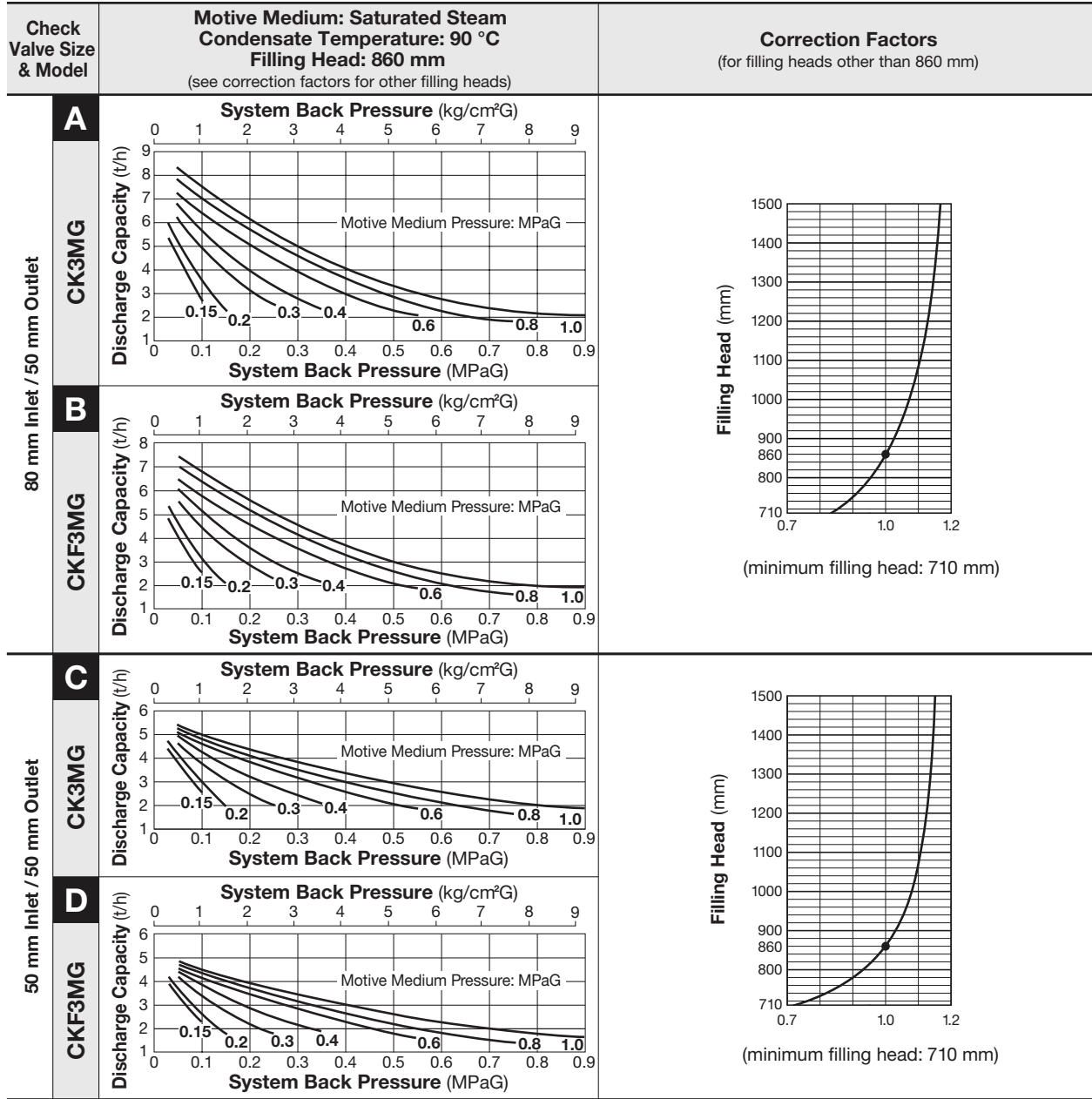

NOTE:

- A check valve must be installed at both the pumped medium inlet and outlet. To achieve the above capacities with the standard GT10 configuration, TLV CK3MG or CKF3MG check valves must be used.
- Motive medium pressure minus back pressure must be greater than 0.05 MPa.
- A strainer must be installed at the motive medium and pumped medium inlets.

● Illustration of Filling Head and Pressure

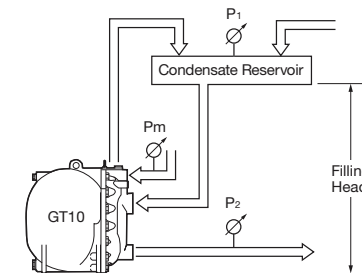

The discharge capacity is determined by the motive medium, motive medium pressure (P_m) and back pressure (P_2).

Make sure that:
 Discharge Capacity × Correction Factor > Required Flow Rate

Dimensions

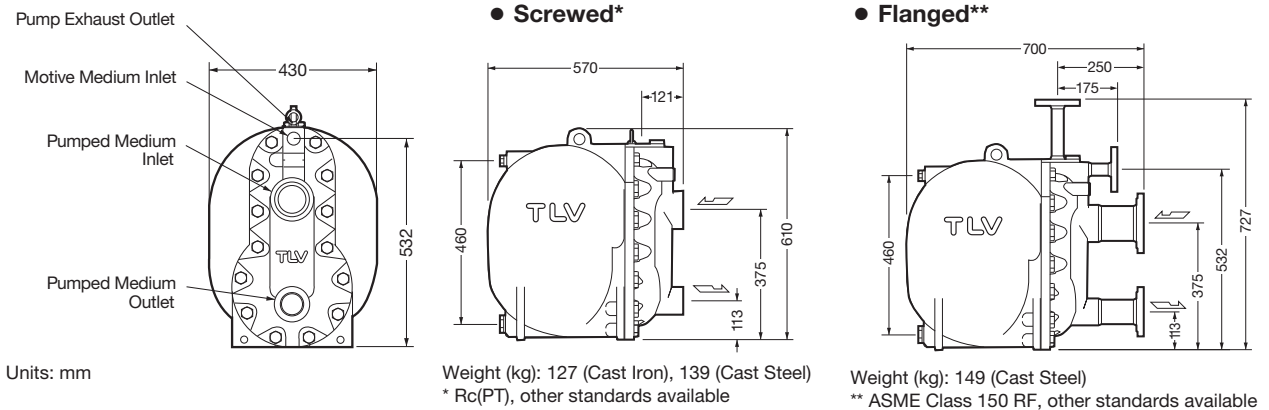

Size of Reservoir

The reservoir must have a capacity sufficient to store the condensate produced during the **PowerTrap** operation and discharge.

Size of Reservoir (flash steam is not involved)

Amount of Condensate (kg/h)	Reservoir Diameter (mm) and Length (m)						
	40	50	80	100	150	200	250
300 or less	1.2 m	0.7					
400	1.5	1.0					
500	2.0	1.2	0.5				
600		1.5	0.6				
800		2.0	0.8	0.5			
1000			1.0	0.7			
1500			1.5	1.0			
2000			2.0	1.3	0.6		
3000				2.0	0.9	0.5	
4000					1.2	0.7	
5000					1.4	0.8	0.5
6000					1.7	1.0	0.6
7000					2.0	1.2	0.7
8000						1.3	0.8
9000						1.5	0.9
10000						1.7	1.0

Reservoir length can be reduced by 50% when the motive medium pressure (P_m) divided by back pressure (P_2) equals 2 or greater (when $P_m \div P_2 \geq 2$).

Steam Consumption (Motive Medium)

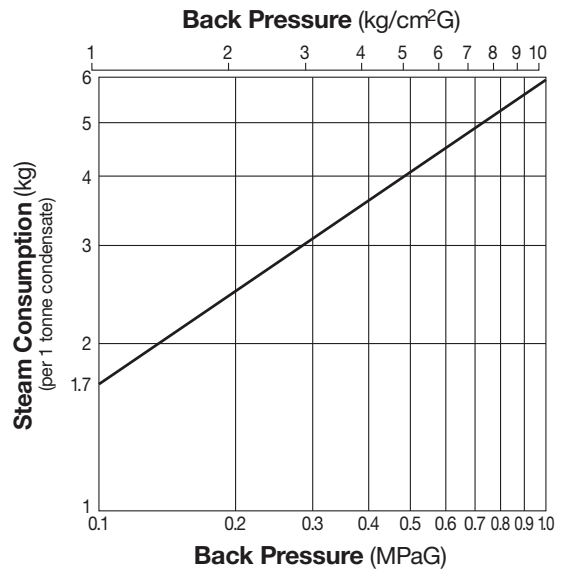

GT10 Steam Trap Discharge Capacity

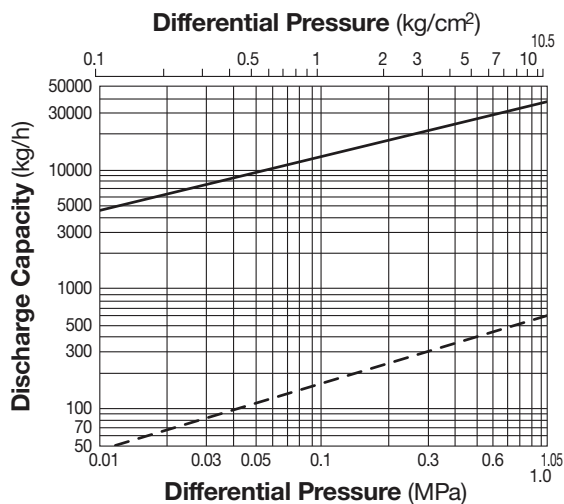

— : Capacity of GT10 as a steam trap ($P_1 > P_2$).
Instantaneous condensate loads above the rated trap capacity will cause the pump to cycle and therefore reduce the discharge capacity.

- - - : Minimum amount of condensate required to prevent steam leakage.

- Capacities are based on continuous discharge of condensate 6 °C below steam temperature.
- Differential pressure is the difference between inlet and outlet pressure of the trap.



DO NOT use this product under conditions that exceed maximum differential pressure, as condensate backup will occur!

Memo:

Manufacturer
TLV® **CO., LTD.**
Kakogawa, Japan
is approved by LRQA Ltd. to ISO 9001/14001

