



Y-STRAINER

MODEL Y8F

FLANGED STRAINER IN ALL NOMINAL SIZES WITH STANDARD OR OPTIONAL FINE MESH

Features

Y-shaped strainer with drain plug for use with steam, water and other fluids*.

1. Simple yet rugged construction ensures long service life.
2. Screen made of durable stainless steel.
3. Designed for easy inline cleaning and maintenance.
4. DN 150 and larger screens have a perforated stainless steel supporting basket.
5. Precise screen guidance in cover and body.



* Do not use for toxic, flammable or otherwise hazardous fluids.

Specifications

Model	Y8F-16	Y8F-25	Y8F-40
Body Material	Cast Iron EN-GJL-250	Ductile Cast Iron EN-GJS-400-18-LT	Cast Steel GP240GH
Connection	Flanged PN 16	Flanged PN 25	Flanged PN 40
Size	DN 15 to 200		
Standard Mesh Size* (Mesh/cm ²)	45		

* Optional fine mesh available on request

Operating Pressure & Temperature

Model	-20	-10	50	100	120	150	200	250	300	350	400	Temperature (°C)
Y8F-16	—	1.6	1.6	1.6	1.6	1.44	1.28	1.12	0.96	—	—	Maximum Operating Pressure (MPaG)
Y8F-25	—	2.5	2.5	2.5	2.5	2.43	2.3	2.18	2.0	1.75	—	
Y8F-40	3.0	4.0	4.0	3.71	3.63	3.52	3.33	3.04	2.67	2.57	2.38	



To avoid abnormal operation, accidents or serious injury, DO NOT use this product outside of the specification range. Local regulations may restrict the use of this product to below the conditions quoted.

No.	Description	Material	DIN*	
①	Body	Y8F-16	Cast Iron EN-GJL-250	0.6025
		Y8F-25	Ductile Cast Iron EN-GJS-400-18-LT	0.7043
		Y8F-40	Cast Steel GP240GH	1.0619
②	Cover	Y8F-16	Cast Iron EN-GJL-250	0.6025
		Y8F-25	Ductile Cast Iron EN-GJS-400-18-LT	0.7043
		Y8F-40	Cast Steel GP240GH	1.0619
③	Screen	Stainless Steel	1.4301	
④	Supporting Basket**	Stainless Steel	1.4301	
⑤	Cover Bolt	Y8F-16	Steel 8.8-A2A	—
		Y8F-25	Steel A2-70	—
		Y8F-40	Steel 25CrMo4	—
⑥	Cover Nut	Y8F-16	Steel 8.8-A2A	—
		Y8F-25	Steel A2-70	—
		Y8F-40	Steel C35E	—
⑦	Drain Plug	Steel C35E	—	
⑧	Drain Plug Gasket	Stainless Steel A4	1.4571	
⑨	Cover Gasket	Graphite / Stainless Steel	—	

* Equivalent materials ** DN 150 and larger (not shown)

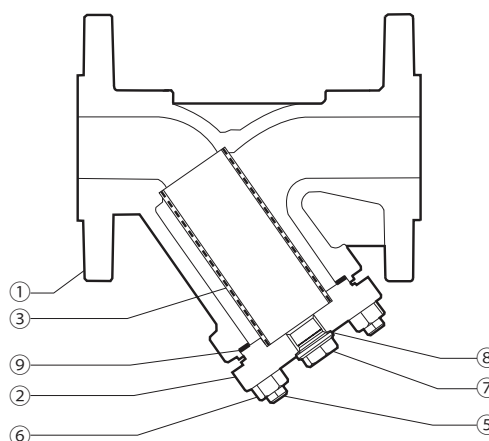

Dimensions

● **Y8F-16 / Y8F-25 / Y8F-40** Flanged

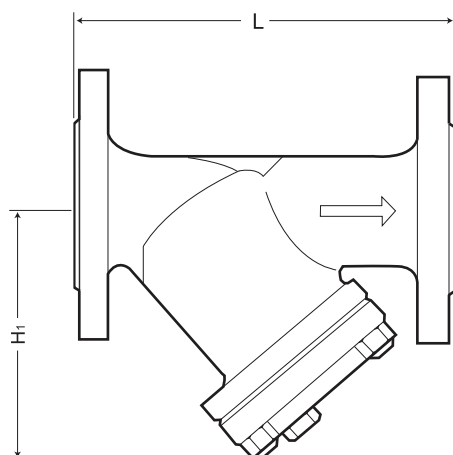

Y8F-16 / Y8F-25 Flanged (mm)

DN	L		H ₁	Weight* (kg)
	DIN 2501			
	PN 16 / PN 25			
15	130		90	2.6
20	150		100	3
25	160		115	4.3
32	180		135	6.8
40	200		150	9
50	230		160	11
65	290		180	17
80	310		215	20
100	350		240	30
125	400		280	43
150	480		330	56
200	600		405	110

* Weight is for PN 25

Y8F-40 Flanged (mm)

DN	L		H ₁	Weight (kg)
	DIN 2501			
	PN 40			
15	130		90	2.7
20	150		100	3.6
25	160		115	4.5
32	180		135	6.3
40	200		150	8.7
50	230		160	11
65	290		180	19
80	310		215	24
100	350		240	33
125	400		280	54
150	480		330	75
200	600		405	137

Cv & Kvs Values

Model	DN	15	20	25	32	40	50	65	80	100	125	150	200
Y8F	Kvs (DIN)	6.2	9.7	14	23	37	54	88	125	189	293	433	760
	Cv (UK)	6.0	9.4	14	23	36	53	85	120	182	282	416	731
	Cv (US)	7.2	11	17	27	43	63	102	144	219	339	500	878

Manufacturer
TLV CO., LTD.
 Kakogawa, Japan
is approved by LRQA Ltd. to ISO 9001/14001

