



# PROCESS FLOAT STEAM TRAP

MODEL JL14-X/JLH14-X CAST IRON/  
CAST STEEL

## HIGH-CAPACITY IRON OR STEEL FLOAT STEAM TRAP WITH THERMOSTATIC AIR VENTING

### Features

**Extremely durable, inline-repairable, compact float trap with thermostatic air venting for large process or heating equipment.**

1. Double-seated valve with heat-treat hardened valve seat and valve head provides continuous, smooth, low-velocity condensate discharge as process loads vary.
2. Self-aligning valve mechanism with stainless steel internals minimizes wear.
3. Thermostatic capsule (X-element) with "fail open" feature vents air automatically until close-to-steam temperature.
4. Easy, inline access to internal parts simplifies cleaning and reduces maintenance costs.
5. High-quality stainless steel internals and hardened valve surfaces ensure reliability.

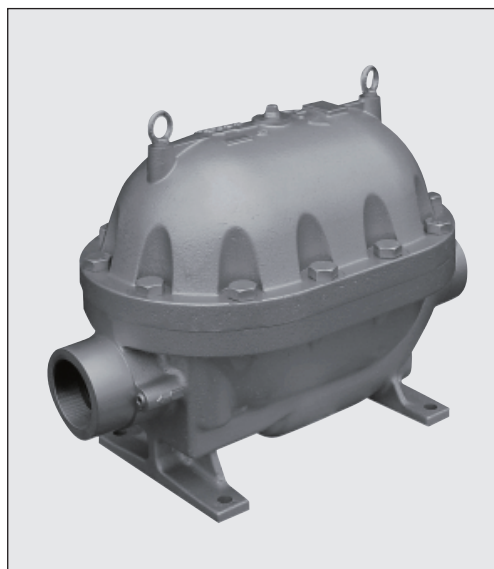

### Pressure Equipment Directive (PED)

Classification according to PED 2014/68/EU, fluid group 2

Size	Category	CE marking
DN 80	II	With CE marking and Declaration of Conformity

### Specifications

Model	JL14-X		JLH14-X		
	Screwed	Flanged*	Screwed	Socket Welded	Flanged
Connection					
Size / DN	3"	DN 80	3"	DN 80	
Orifice No.	10, 13		10, 18, 32		
Maximum Operating Pressure (barg) PMO	10, 13		10, 18, 32		
Maximum Differential Pressure (bar) ΔPMX	10, 13		10, 18, 32		
Maximum Operating Temperature (°C) TMO	200		240 (400**)		

\* JL14-X has a screwed-in flange \*\* Optional JLH14-B with bimetal-type air vent unit for initial air venting 1 bar = 0.1 MPa  
 PRESSURE SHELL DESIGN CONDITIONS (NOT OPERATING CONDITIONS): Maximum Allowable Pressure (barg) PMA: 13 (JL14-X), 32 (JLH14-X)  
 Maximum Allowable Temperature (°C) TMA: 200 (JL14-X), 400 (JLH14-X)



To avoid abnormal operation, accidents or serious injury, DO NOT use this product outside of the specification range. Local regulations may restrict the use of this product to below the conditions quoted.

No.	Description	Material	DIN*	ASTM/AISI†	
①	Body	JL14-X	Cast Iron FC250	0.6025	A126 Cl. B
		JLH14-X	Cast Steel A216 Gr. WCB	1.0619	—
②	Cover	JL14-X	Cast Iron FC250	0.6025	A126 Cl. B
		JLH14-X	Cast Steel A216 Gr. WCB	1.0619	—
③	Cover Gasket	Graphite/Stainless Steel SUS316L	— / 1.4404	— / AISI316L	
④	Cover Bolt	JL14-X	Carbon Steel S45C	1.0503	AISI1045
		JLH14-X	Alloy Steel SNB7	1.7225	A193 Gr. B7
⑤	Float / Lever Unit	Stainless Steel SUS316L / Cast Stainl. Steel A351 Gr. CF8	1.4404 / 1.4312	AISI316L / —	
⑥	Trap Unit (Main Valve Unit)	Stainless Steel SUS304 / Cast Stainl. Steel A743 Gr. CA40	1.4301 / 1.4027	AISI304 / —	
⑦	Air Vent Unit	Stainless Steel SUS304/420F	1.4301 / 1.4028	AISI304 / 420F	
⑧	Cover Plug	JL14-X	Carbon Steel SS400	1.0037	A6
		JLH14-X	Carbon Steel S25C	1.1158	AISH1025
⑨	Cover Plug Gasket (JLH14-X)	JL14-X	Carbon Steel SS400	1.0037	A6
		JLH14-X	Carbon Steel S25C	1.1158	AISH1025
⑩	Drain Plug	JL14-X	Carbon Steel SS400	1.0037	A6
		JLH14-X	Carbon Steel S25C	1.1158	AISH1025
⑪	Drain Plug Gasket (JLH14-X)	JL14-X	Carbon Steel SS400	1.0037	A6
		JLH14-X	Carbon Steel S25C	1.1158	AISH1025
⑫	Nameplate	Stainless Steel SUS304	1.4301	AISI304	
⑬	Eye Bolt	Carbon Steel SS400	1.0037	A307 Gr.B	
⑭	Flange**	Cast Steel A216 Gr. WCB	1.0619	—	
⑮	Flange Pipe**	JL14-X	Carbon Steel STPG370	1.0308	A53 Type S Gr.A
		JLH14-X	Stainless Steel SUS304	1.4301	AISI304

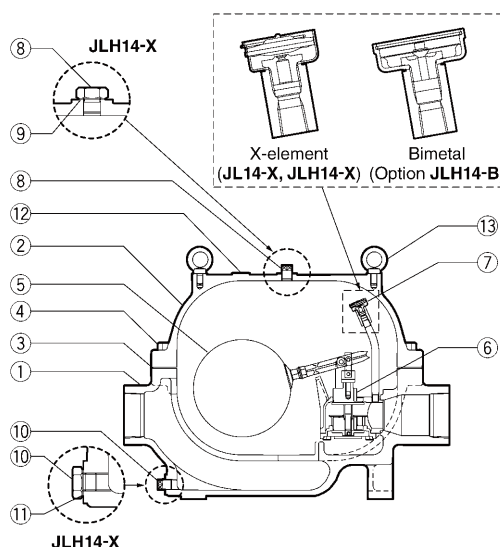

\* Equivalent materials \*\* Shown on reverse

**Dimensions**

• **JL14-X/JLH14-X** Screwed

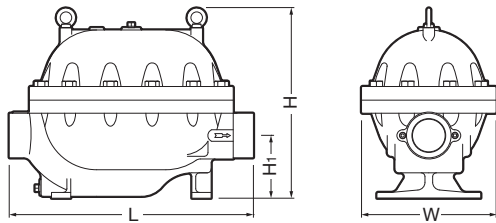

JL14-X shown.

• **JLH14-X** Socket Welded

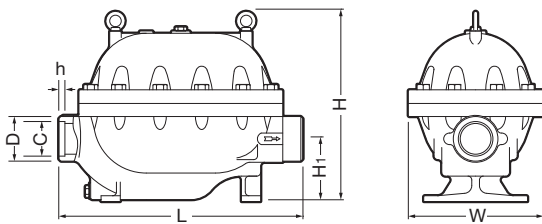

• **JL14-X/JLH14-X** Flanged

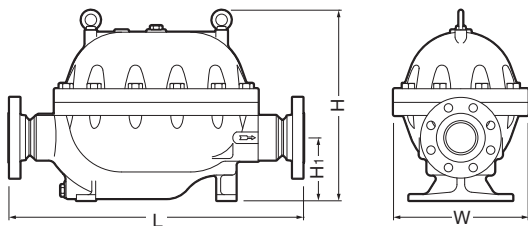

JLH14-X shown.

**JL14-X/JLH14-X** Screwed\* (mm)

Size	L	H	H <sub>1</sub>	W	Weight (kg)
3"	635	490	163	350	107 [110]

\* BSP DIN 2999, other standards available  
 [ ] JLH14-X

**JLH14-X** Socket Welded\* (mm)

DN	L	H	H <sub>1</sub>	W	φD	φC	h	Weight (kg)
80	635	490	163	350	105	89.8	16	110

\* ASME B16.11-2005, other standards available

**JL14-X\*/JLH14-X** Flanged (mm)

DN	L				H	H <sub>1</sub>	W	Weight** (kg)
	DIN 2501		ASME Class					
	PN16	PN25/40	150RF	300RF				
80	766	766	766	766	490	163	350	121 [124]

PN 16 for JL14-X, PN 25/40 for JLH14-X  
 Other standards available, but length and weight may vary  
 \* JL14-X has a screwed-in flange  
 \*\* Weight is for DIN PN 25/40  
 [ ] JLH14-X

**Discharge Capacity**

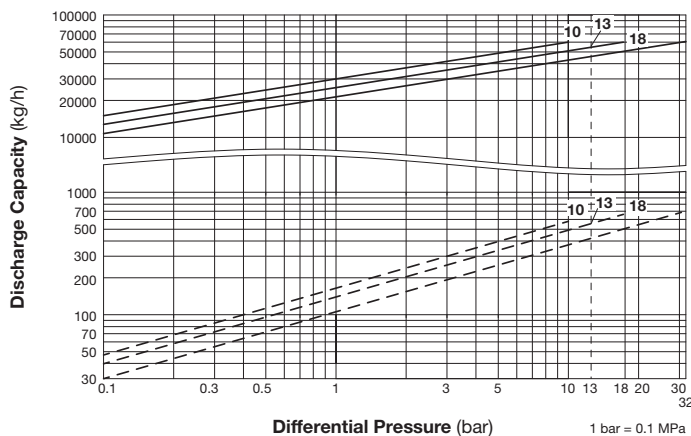

— : Maximum capacity of JL14-X/JLH14-X.  
 - - - : Minimum amount of condensate required to prevent steam leakage.

1. Line numbers within the graph refer to orifice numbers.
2. Differential pressure is the difference between the inlet and outlet pressure of the trap.
3. Capacities are based on continuous discharge of condensate 6 °C below saturated steam temperature.
4. Recommended safety factor: 1.5.



DO NOT use this product under conditions that exceed maximum differential pressure, as condensate backup will occur!

Manufacturer  
**TLV** CO., LTD.  
 Kakogawa, Japan  
 is approved by LRQA Ltd. to ISO 9001/14001

