



FREE FLOAT® STEAM TRAP

MODEL SJ6FX DUCTILE CAST IRON

FREE FLOAT STEAM TRAP WITH THREE-POINT SEATING AND THERMOSTATIC AIR VENTING

Features

Reliable and durable steam trap with tight shut-off for use on medium process equipment. Models for horizontal or vertical piping installation.

1. Self-modulating free float provides continuous, smooth, low-velocity condensate discharge as process loads vary.
2. Precision-ground float, constant water seal and three-point seating design ensure a steam-tight seal, even under no-load conditions.
3. Thermostatic capsule (X-element) with "fail open" feature vents air automatically until close-to-steam temperature.
4. Built-in screen with large surface area ensures extended trouble-free operation.
5. Easy, inline access to internal parts simplifies cleaning and reduces maintenance costs.

Pressure Equipment Directive (PED)

Classification according to PED 2014/68/EU, fluid group 2

Size	Category	CE marking
DN 40, DN 50	I	with CE marking and Declaration of Conformity



Specifications

Model	SJ6FNX	SJ6FVX
Installation	Horizontal	Vertical
Connection	Flanged	
Size	DN 40, 50	
Orifice No.	2, 5, 9, 14, 22	
Maximum Operating Pressure (barg) PMO	2, 5, 9, 14, 22	
Maximum Differential Pressure (bar) ΔPMX	2, 5, 9, 14, 22	
Maximum Operating Temperature (°C) TMO	220	
Subcooling of X-element Fill (°C)	up to 6	
Type of X-element	C6	

PRESSURE SHELL DESIGN CONDITIONS (NOT OPERATING CONDITIONS): Maximum Allowable Pressure (barg) PMA: 22
Maximum Allowable Temperature (°C) TMA: 220
Minimum Allowable Temperature (°C): 0
1 bar = 0.1 MPa



To avoid abnormal operation, accidents or serious injury, DO NOT use this product outside of the specification range. Local regulations may restrict the use of this product to below the conditions quoted.

No.	Description	Material	DIN*	ASTM/AISI*
①	Body	Ductile Cast Iron GGG40.3/EN 5.3103 (EN-GJS-400-18-LT)	0.7043	A395 Gr.60-40-18
②	Cover	Ductile Cast Iron GGG40.3/EN 5.3103 (EN-GJS-400-18-LT)	0.7043	A395 Gr.60-40-18
③ ^{MR}	Cover Gasket	Fluorine Resin PTFE	PTFE	PTFE
④ ^F	Float	Stainless Steel SUS316L	1.4404	AISI316L
⑤ ^R	Orifice	—	—	—
⑥ ^{MR}	Orifice Gasket	Fluorine Resin PTFE	PTFE	PTFE
⑦ ^R	X-element Screen	Stainless Steel SUS304	1.4301	AISI304
⑧ ^R	Screen	Stainless Steel SUS430	1.4016	AISI430
⑨	Screen Holder	Cast Stainl. Steel A351/A351M Gr.CF8	1.4312	—
⑩ ^{MR}	Screen Holder Gasket	Soft Iron SUYP	1.1121	AISI1010
⑪	Orifice Plug (SJ6FNX)	Cast Stainl. Steel A351/A351M Gr.CF8	1.4312	—
⑫ ^{MR}	Orifice Plug Gasket (SJ6FNX)	Soft Iron SUYP	1.1121	AISI1010
⑬	Drain Plug	Carbon Steel SS400	1.0037	A6
⑭ ^R	X-element	Stainless Steel	—	—
⑮ ^R	X-element Guide	Stainless Steel SUS304	1.4301	AISI304
⑯	X-element Cover	Cast Stainl. Steel A351/A351M Gr.CF8	1.4312	—
⑰ ^R	Air Vent Valve Seat	Stainless Steel SUS420F	1.4028	AISI420F
⑱ ^R	Cover Bolt	Carbon Steel S45C	1.0503	AISI1045
⑲ ^R	Spring Clip	Stainless Steel SUS304	1.4301	AISI304
⑳ ^{MR}	X-element Cover Gasket	Fluorine Resin PTFE	PTFE	PTFE
㉑	Nameplate	Stainless Steel SUS304	1.4301	AISI304

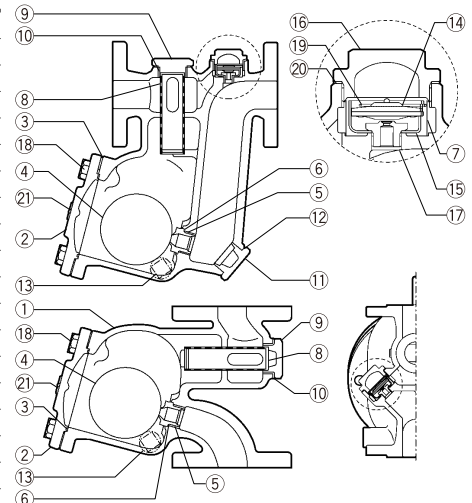

Copyright © TLV

* Equivalent materials
Replacement kits available: (M) maintenance parts, (R) repair parts, (F) float

Dimensions

● **SJ6FNX** Flanged

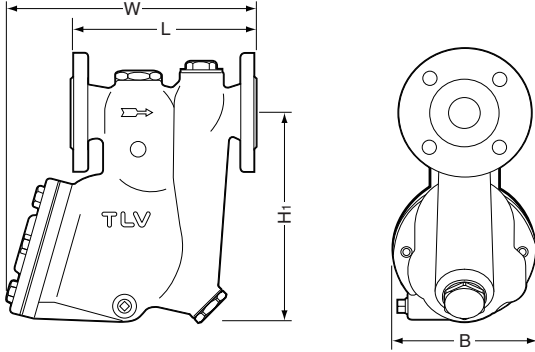

SJ6FNX Flanged (mm)

DN	L	H ₁	W	B	Weight (kg)
	DIN 2501 PN25/40				
40	230	268	311	176	22
50					24

● **SJ6FVX** Flanged

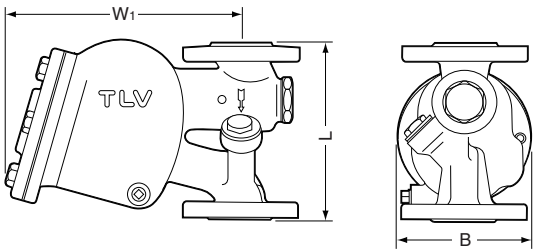

SJ6FVX Flanged (mm)

DN	L	W ₁	B	Weight (kg)
	DIN 2501 PN25/40			
40	230	263	176	17
50				18

Discharge Capacity

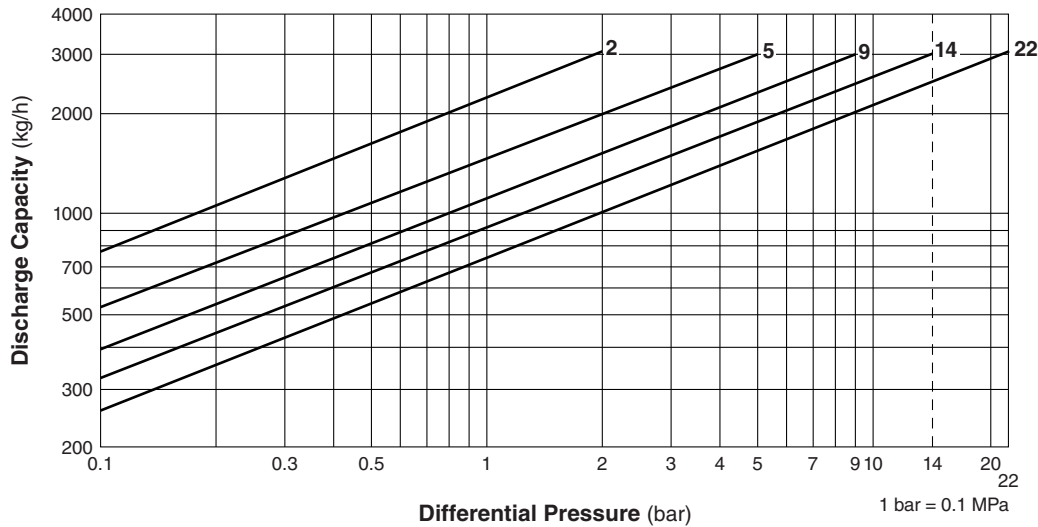

1. Line numbers within the graph refer to orifice numbers.
2. Differential pressure is the difference between the inlet and outlet pressure of the trap.
3. Capacities are based on continuous discharge of condensate 6 °C below saturated steam temperature.
4. Recommended safety factor: at least 1.5.

CAUTION DO NOT use this product under conditions that exceed maximum differential pressure, as condensate backup will occur!

Manufacturer
TLV CO., LTD.
 Kakogawa, Japan
 is approved by LRQA Ltd. to ISO 9001/14001

