



Manufacturer

TLV CO., LTD.

Kakogawa, Japan

is approved by LRQA Ltd. to ISO 9001/14001

TLV®

Instruction Manual

PowerTrap® **GP10F**

Copyright © 2020 by TLV CO., LTD.

All rights reserved

Contents

Introduction	2
Safety Considerations	3
General Description	5
Application	5
Operation	6
Specifications	7
Configuration	7
Installation	8
Open System* Piping (Steam System Example)	8
Installation Procedure	9
Sizing the Condensate Receiver/Reservoir	13
Installing Several PowerTrap Units in Parallel	16
Installation and Maintenance Space	17
Operation and Periodic Inspection	18
Operation	18
Periodic Inspection and Diagnosis	19
Disassembly/Reassembly	21
Recommended Tools List for Disassembly/Reassembly	22
1. Removing/Reattaching the Cover Unit	23
2. Removing/Reattaching the Float	24
3. Removing/Reattaching the Snap-action Unit	24
4. Removing/Reinstalling the Exhaust Valve	25
5. Removing/Reinstalling the Exhaust Valve Seat	25
6. Removing/Reinstalling the Motive Medium Intake Valve and Valve Seat	26
7. Checking/Adjusting the Gap between the Push Plate and the Motive Medium Intake Valve	27
Troubleshooting	28
Determining the Problem from the Symptoms	28
Types of Failure and their Causes	29
Causes and Corrective Measures	30
Product Warranty	33
Service	34

Introduction

Thank you for purchasing the TLV PowerTrap.

This product has been thoroughly inspected before being shipped from the factory. When the product is delivered, before doing anything else, check the specifications and external appearance to make sure nothing is out of the ordinary. Also be sure to read this manual carefully before use and follow the instructions to be sure of using the product properly.





If detailed instructions for special order specifications or options not contained in this manual are required, please contact TLV for full details.



This instruction manual is intended for use with the model(s) listed on the front cover. It is necessary not only for installation, but for subsequent maintenance, disassembly/reassembly and troubleshooting. Please keep it in a safe place for future reference.

Safety Considerations

- Read this section carefully before use and be sure to follow the instructions.
- Installation, inspection, maintenance, repairs, disassembly, adjustment and valve opening/closing should be carried out only by trained maintenance personnel.
- The precautions listed in this manual are designed to ensure safety and prevent equipment damage and personal injury. For situations that may occur as a result of erroneous handling, three different types of cautionary items are used to indicate the degree of urgency and the scale of potential damage and danger: DANGER, WARNING and CAUTION.
- The three types of cautionary items above are very important for safety: be sure to observe all of them as they relate to installation, use, maintenance and repair. Furthermore, TLV accepts no responsibility for any accidents or damage occurring as a result of failure to observe these precautions.

Symbols

	Indicates a DANGER, WARNING or CAUTION item.
	Indicates an urgent situation which poses a threat of death or serious injury
	Indicates that there is a potential threat of death or serious injury
	Indicates that there is a possibility of injury or equipment / product damage

	<p>NEVER apply direct heat to the float. The float may explode due to increased internal pressure, causing accidents leading to serious injury or damage to property and equipment.</p>
	<p>Install properly and DO NOT use this product outside the recommended operating pressure, temperature and other specification ranges. Improper use may result in such hazards as damage to the product or malfunctions that may lead to serious accidents. Local regulations may restrict the use of this product to below the conditions quoted.</p>
	<p>Use hoisting equipment for heavy objects (weighing approximately 20 kg or more). Failure to do so may result in back strain or other injury if the object should fall.</p>
	<p>Take measures to prevent people from coming into direct contact with product outlets. Failure to do so may result in burns or other injury from the discharge of fluids.</p>
	<p>When disassembling or removing the product, wait until the internal pressure equals atmospheric pressure and the surface of the product has cooled to room temperature. Disassembling or removing the product when it is hot or under pressure may lead to discharge of fluids, causing burns, other injuries or damage.</p>

Continued on next page

 CAUTION	Be sure to use only the recommended components when repairing the product, and NEVER attempt to modify the product in any way. Failure to observe these precautions may result in damage to the product and burns or other injury due to malfunction or the discharge of fluids.
	Do not use excessive force when connecting threaded pipes to the product. Over-tightening may cause breakage leading to fluid discharge, which may cause burns or other injury.
	Use only under conditions in which no freeze-up will occur. Freezing may damage the product, leading to fluid discharge, which may cause burns or other injury.
	Use only under conditions in which no water hammer will occur. The impact of water hammer may damage the product, leading to fluid discharge, which may cause burns or other injury.
	Take measures to ensure the proper handling, such as recovery or dilution, of hazardous fluids discharged at product outlets. Outflow of fluid or fluid leaks may lead to hazards such as flammable conditions or corrosion, which may result in injury, fires, damage or other accidents.

General Description



Install properly and **DO NOT** use this product outside the recommended operating pressure, temperature and other specification ranges. Improper use may result in such hazards as damage to the product or malfunctions which may lead to serious accidents. Local regulations may restrict the use of this product to below the conditions quoted.

Application

The PowerTrap is used to discharge liquid from vacuum-pressure or low-pressure areas to high-pressure areas, or from lower to higher elevations.

There are two types of delivery systems (piping methods): the closed system and the open system. The GP10F is for use with open systems. It can be used with closed systems, but only where there is **always** a **negative** pressure differential (e.g. vacuum equipment). Other PowerTrap models are available for different systems.

Check to make sure which PowerTrap model is most suitable for use on the type of system that is being planned for installation.

Type of System	Closed System	Open System
System Overview		
Benefits	<ul style="list-style-type: none"> No need for external steam trap (GT model features built-in trap) No flash steam discharge Small reservoir Use with vacuum equipment possible 	<ul style="list-style-type: none"> Collection of condensate from multiple equipment possible Can be used where trap is lower than receiver, such as equipment situated near grade (providing there is sufficient differential pressure)
Notes	<ul style="list-style-type: none"> Only one piece of equipment possible per system Equipment has minimum height requirement to ensure that condensate flows naturally by gravity (approx: GP14/GT14/GP10/GT10 –0.8 m; GP10F - 1 m, GP10M/GT10M – 0.3 m; GP10L/GT10L –0.3 or 0.5 m; GT5C – 170 mm) 	<ul style="list-style-type: none"> Separate steam trap required for each piece of equipment Requires venting pipe to discharge flash steam to atmosphere
Model	<p>Mechanical pump with built-in trap GT14/GT10/GT10L/ GT14L/GT14M/GT5C</p> <p>Where there is ALWAYS a negative pressure differential (e.g. vacuum equipment), GP14/GP10/GP10L/GP14L/ GP14M/GP5C/GP10F can be used</p>	<p>Mechanical pump GP14/GP10/GP10L/GP14L/ GP14M/GP5C/GP10F</p>

Operation



Take measures to prevent people from coming into direct contact with product outlets. Failure to do so may result in burns or other injury from the discharge of fluids.

- (1) When condensate flows from the condensate inlet pipe through the inlet check valve into the body of the unit, the air in the body escapes through the exhaust valve (which equalizes the internal pump pressure to the pressure of the condensate source) and the float rises, as shown in (1) below.
- (2) When the float rises to its high level, the push rod on the snap-action unit rises quickly, simultaneously closing the exhaust valve and opening the intake (motive medium) valve. The pressure supplied by the motive medium causes the internal pressure in the unit to become greater than the back pressure. The inlet check valve closes and the outlet check valve is pushed open, thus discharging the condensate in the unit through the outlet pipe, as shown in (2) below.
- (3) As a result of the condensate in the unit being discharged, the water level in the unit drops and the float descends. When the float reaches its low level, the push rod on the snap-action unit moves down quickly, simultaneously opening the exhaust valve and closing the intake (motive medium) valve and the status reverts to that shown in (1) below.

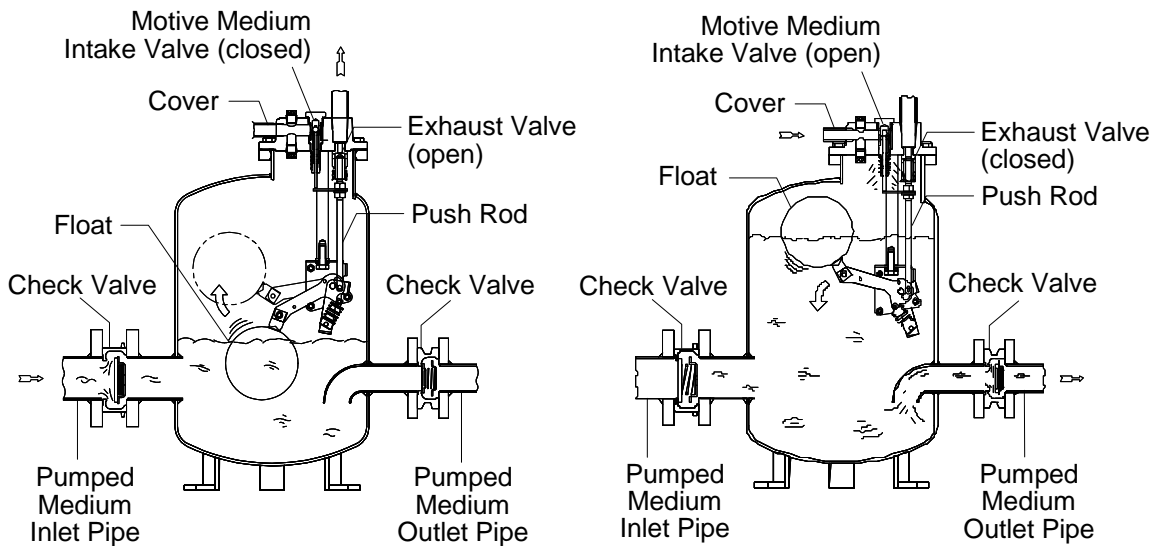

(1) Pumped Medium Inflow

(2) Pumped Medium Discharge

Specifications



Install properly and **DO NOT** use this product outside the recommended operating pressure, temperature and other specification ranges. Improper use may result in such hazards as damage to the product or malfunctions which may lead to serious accidents. Local regulations may restrict the use of this product to below the conditions quoted.



Use only under conditions in which no freeze-up will occur. Freezing may damage the product, leading to fluid discharge, which may cause burns or other injury.

Refer to the product nameplate for detailed specifications.

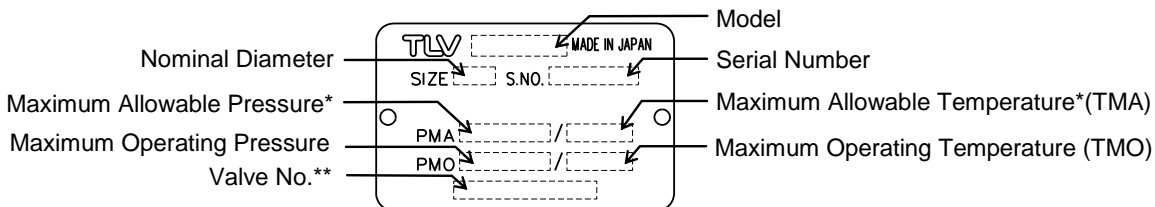

Motive Medium Pressure Range	0.3 to 10.5 barg / 0.03 to 1.05 MPaG
Max. Allowable Back Pressure	0.5 bar / 0.05 MPa less than motive medium pressure used

* Maximum allowable pressure (PMA) and maximum allowable temperature (TMA) are PRESSURE SHELL DESIGN CONDITIONS, **NOT** OPERATING CONDITIONS.
 ** Valve No. is displayed for products with options. This item is omitted from the nameplate when there are no options.

Configuration

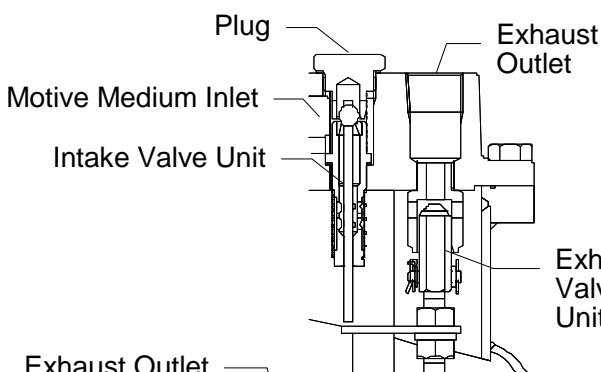

Connection	Type	Size
Motive Medium Inlet	Screwed	3/4 in
Exhaust Outlet	Screwed	1 in
Pumped Medium Inlet	Flanged	DN 80
Pumped Medium Outlet	Flanged	DN 50

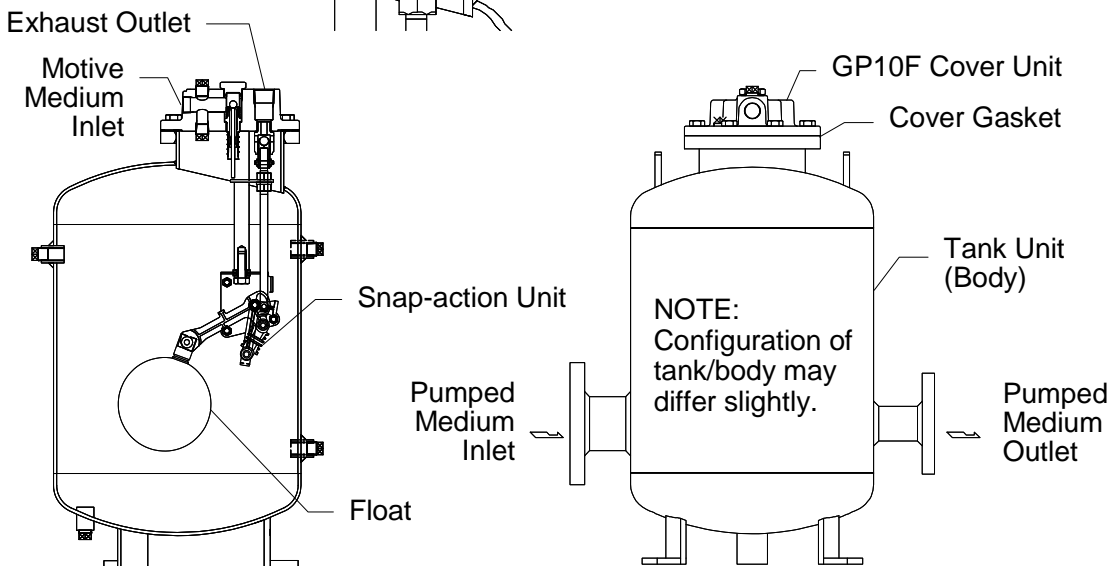

Installation

- CAUTION** Install properly and **DO NOT** use this product outside the recommended operating pressure, temperature and other specification ranges. Improper use may result in such hazards as damage to the product or malfunctions which may lead to serious accidents. Local regulations may restrict the use of this product to below the conditions quoted.
- CAUTION** Use hoisting equipment for heavy objects (weighing approximately 20 kg or more). Failure to do so may result in back strain or other injury if the object should fall.
- CAUTION** Take measures to prevent people from coming into direct contact with product outlets. Failure to do so may result in burns or other injury from the discharge of fluids.
- CAUTION** Do not use excessive force when connecting threaded pipes to the product. Over-tightening may cause breakage leading to fluid discharge, which may cause burns or other injury.
- CAUTION** Use only under conditions in which no water hammer will occur. The impact of water hammer may damage the product, leading to fluid discharge, which may cause burns or other injury.

Open System* Piping (Steam System Example)

If water hammer due to steam backflow in the condensate recovery line is expected, installation of a check valve vertically and as close as possible to the recovery line is recommended.

Note: This sketch is for explanation purposes only and is not intended as an installation design.

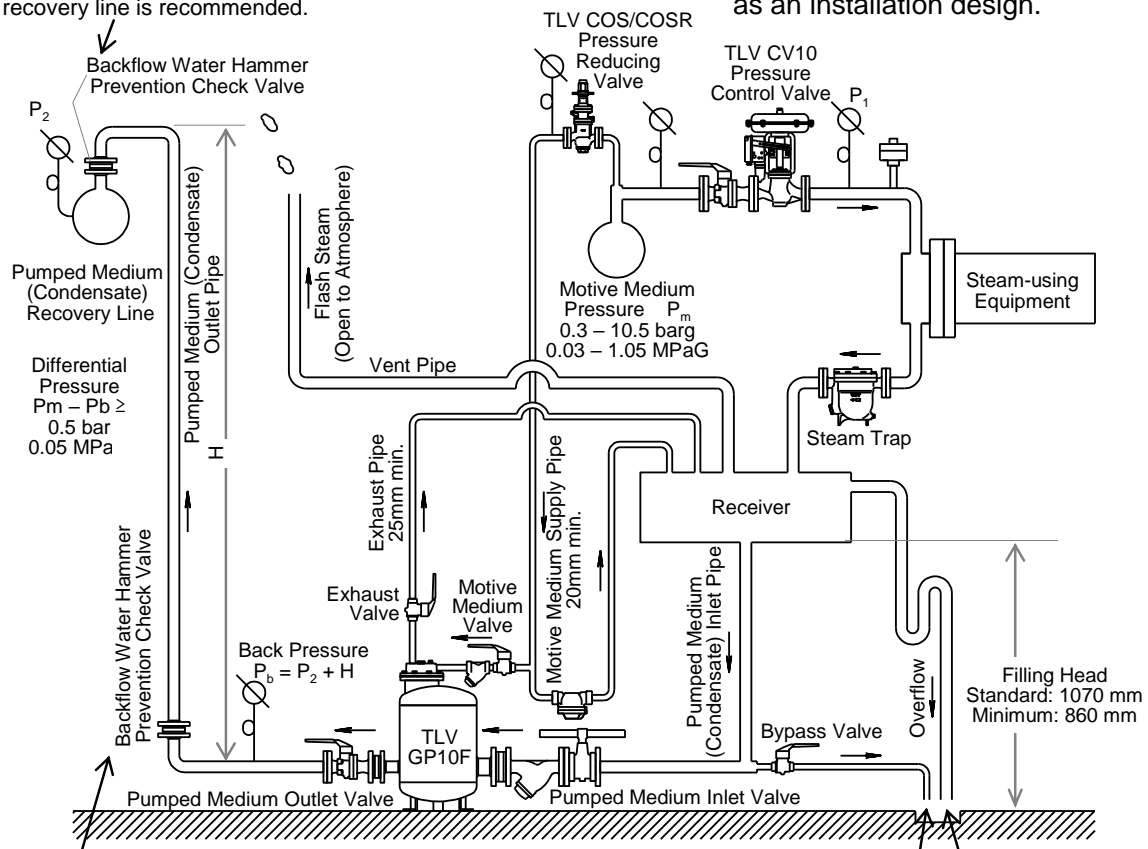

When the rise in piping to the condensate recovery line is 30 m or farther from GP10F, installation of a check valve is recommended for the prevention of return water hammer.

Pipe the discharge to a safe area such as a pit.

* Consult with TLV for closed system piping.

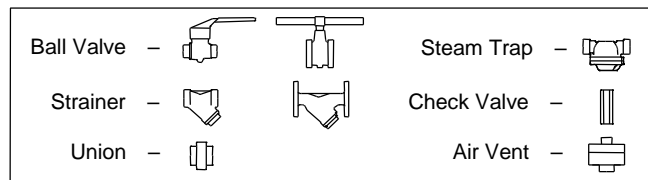

Installation Procedure

Refer to the systems outlined in the “General Description” section on page 5 to select the correct system and model (GT or GP) for the application. Installation, inspection, maintenance, repairs, disassembly, adjustment and valve opening/closing should be carried out only by trained maintenance personnel.

(1) Pumped Medium:

- Fluids that can be discharged through the PowerTrap are limited to steam condensate, water and non-flammable, non-toxic fluids with specific gravities 0.85 to 1.0. PowerTraps that have been constructed for other specific fluids are not limited by this restriction.

(2) Motive Medium Supply Piping:

- The motive medium supply pipe diameter should be at least 20 mm.
- Install a 40-mesh or finer strainer on the PowerTrap motive medium supply pipe, as close to the PowerTrap as possible, while allowing sufficient space for maintenance of the strainer. Strainers should be angled in the 3 or 9 o'clock positions for horizontal installations.
- The motive medium inlet pressure should be between 0.3 to 10.5 barg (0.03 to 1.05 MPaG), and at least 0.5 bar (0.05 MPa) greater than the system back pressure.
- **For open systems:**
Steam, compressed air, nitrogen or other non-flammable, non-toxic fluids may be used as the motive medium.
- **For closed systems:**
Use steam or some other such condensable gas as the motive medium. Except in special cases, do not use non-condensable gases such as air or nitrogen
- When the motive medium is steam, if the application will require that the equipment be shut down (non-operating) for periods of 2 months or longer, install piping connecting the motive medium supply line to the receiver, being sure to install a drip leg on the motive medium supply line, and a steam trap in the drip leg (between where it branches to go to the PowerTrap and where it enters the receiver). This measure is not necessary when the motive medium is compressed air or nitrogen.

(3) Pressure Reducing Valve on the Motive Medium Supply Piping:

- When the motive medium pressure is greater than the maximum allowed for the particular PowerTrap model used (see “Specifications”), install a TLV COS/COSR series pressure reducing valve in order to reduce the motive medium pressure to the PowerTrap. Use good piping practices when selecting the installation location for COS/COSR. Be sure to install a safety valve between the pressure reducing valve and the PowerTrap.
- When the motive medium pressure is less than the maximum allowed for the particular PowerTrap model used, if a reducing valve is to be installed to slow the speed of the flow, the installation of a safety valve is not required.
- Install the pressure reducing valve as far away from the PowerTrap as possible.
 - When the motive medium pressure is less than 5 barg (0.5 MPaG): at least 3 m.
 - When the motive medium pressure is 5 barg or greater (0.5 MPaG or greater): at least 3 m + 1 m for every 1 barg (0.1 MPaG) over 5 barg (0.5 MPaG)

- The pressure setting on the pressure reducing valve should be between 0.5 to 1.5 bar (0.05 and 0.15 MPa) higher than the back pressure.
When the discharge capacity of the PowerTrap is insufficient for the set motive pressure, increase this set pressure even further.

(4) Exhaust Piping:

- The exhaust pipe diameter should be at least 25 mm.
- The exhaust pipe should be connected to the top of the receiver.
- **For open systems:** If the PowerTrap exhaust line has to discharge to atmosphere, a sound level of approximately 90 to 100 dB may be emitted from the exhaust pipe discharge outlet for two to three seconds. If soundproofing measures are necessary, install a silencer. (If the exhaust line is connected to the receiver, the sound level will be below 60 dB.)
- Make sure that the distance from the ground to the highest point on the exhaust pipe (where it enters the receiver) does not exceed 3 m. If it exceeds 3 m, condensate must be drained from the exhaust pipe in order not to obstruct the exhaust. Implement one of the following countermeasures: (See the figures below.)
 - For Open Systems only:** Add a float-type steam trap to the exhaust pipe at a point just above where the exhaust pipe exits the unit body. (Figure 1)
 - For Open and Closed Systems:** Add piping connecting the exhaust pipe to the pumped medium inlet pipe between the reservoir and the strainer, being sure to install a check valve on the piping to prevent backflow of condensate from the pumped medium inlet pipe to the exhaust pipe. (Figure 2)

When the exhaust piping height exceeds 3 m

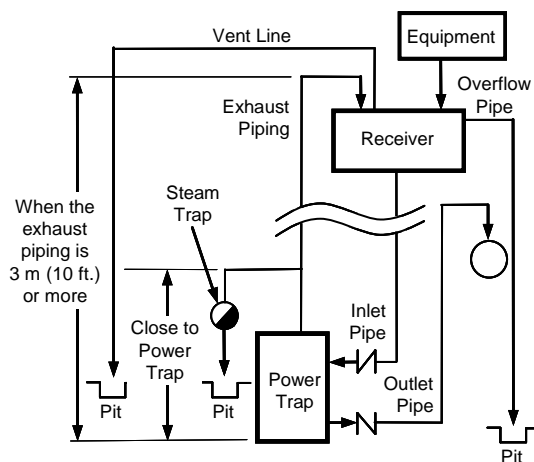

Figure 1: Open Systems

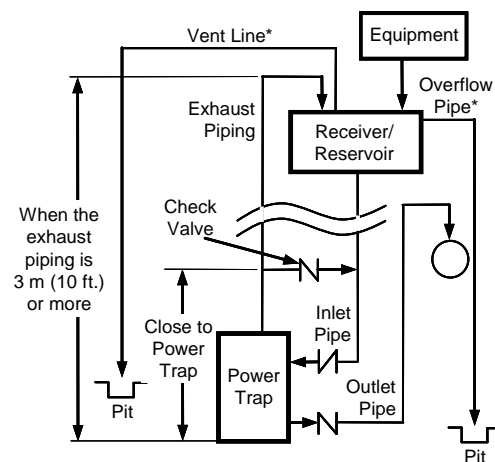

Figure 2: Open & Closed Systems

*For Open Systems only

(5) Inlet and Outlet Piping

- Install a 40-mesh or finer strainer on the PowerTrap pumped medium inlet pipe. The installation should be in a location that allows sufficient space for maintenance of the strainer.
- Ensure that the inlet and outlet check valves are installed in the correct direction. The check valve on the inlet pipe in particular should be installed right next to the PowerTrap.
- Only TLV check valves (CKF3MG) should be used; proper discharge capacity cannot be guaranteed with other check valves.

(6) Valves on the Various Pipes

- In order to ensure the proper discharge capacity, use full bore ball valves or gate valves on the pumped medium inlet and outlet lines as well as on the motive medium supply and exhaust lines. If it is necessary to reduce the velocity of the motive medium supply, a needle valve can be used. However, be aware that the discharge capacity will be reduced. (Refer to “Operation” 1.e in the “Operation” section.)
- Install union or flanged joints between the valves and the PowerTrap to allow for easy maintenance.
- Be sure to provide the necessary maintenance space for PowerTrap disassembly and repair (see the “Installation and Maintenance Space” section).

(7) Receiver and Filling Head.

- Please refer to the “Sizing the Condensate Receiver/Reservoir” section. The size and vent pipe aperture are determined by (a) the amount of any flash steam in the in-flowing condensate (pumped medium) and (b) the amount of pumped medium held back while the PowerTrap is discharging. If the receiver is small, the flow of flash steam may cause condensate to flow out the vent pipe. If the vent pipe size is small, the pressure in the receiver will rise, restricting the pumped medium inflow. Be sure to select a receiver pipe of the correct size.
- The filling head represents the distance from the bottom of the PowerTrap (from grade) to the bottom of the receiver/reservoir. The standard filling head is 1070 mm. When an installation calls for a lower filling head, a filling head of less than 1070 mm is allowable. However, the minimum filling head is 860 mm.
- **For open systems:**
 - If venting flash steam to a high area, an overflow pipe must be installed to discharge condensate to a safe area.
 - Overflow pipe should be installed at the side of the receiver.



- When discharging flash steam from the condensate receiver upward through the pipe to outside atmosphere, be sure to install an overflow pipe and discharge to a safe area such as a pit. Failure to install an overflow pipe is dangerous, as condensate may spurt from the vent pipe and could result in burns and other injuries.
- To minimize the discharge of flash steam from the overflow pipe, use an overflow pipe with a U-shaped section about 300 mm in length.

Examples of Overflow Piping for Open Systems

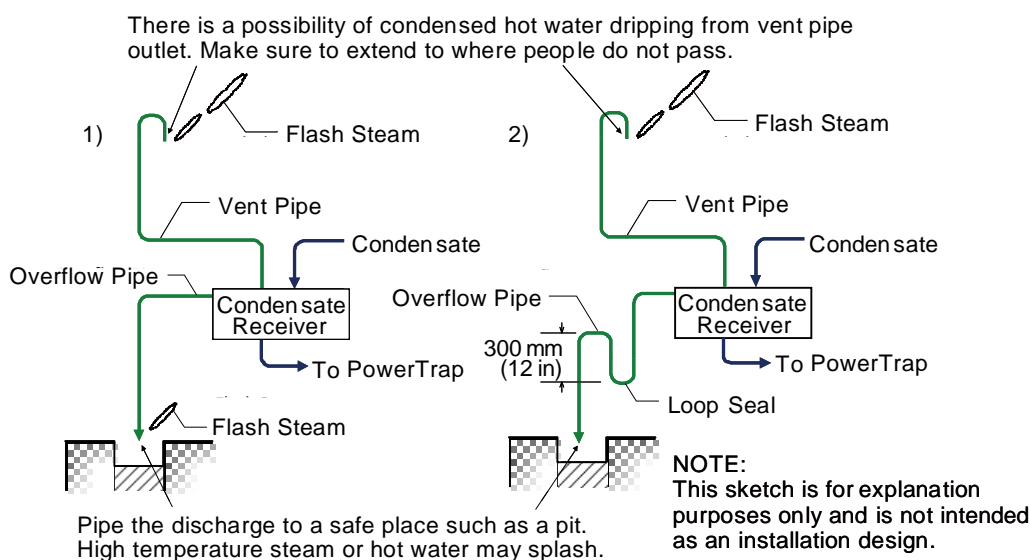

Explanation for overflow piping for open systems

1) If flash steam can be discharged from overflow pipe

Install overflow pipe and vent pipe separately.

2) If flash steam should not be released from overflow pipe (prevent flash steam release)

Install overflow pipe and vent pipe separately. For overflow pipe, install loop seal (approx. 300 mm). Flash steam release from overflow pipe can be prevented since water always accumulates at loop seal. Piping size should be the same or larger than condensate inlet pipe.

NOTE: • There is a possibility of rust becoming clogged and/or corrosion since water always present in the loop seal. The possibility is greater if the piping diameter is too small (generally 25 mm or smaller).

- If the loop seal becomes clogged, hot overflow water will blow from vent pipe. Make sure to install vent pipe to lead to a safe place
- Do not install loop seal on the vent pipe
- Contact TLV if neither 1) nor 2) above can be installed.

(8) Velocity at Outlet Piping

The PowerTrap uses the motive medium supply pressure to push the pumped medium out of the trap.

- The GP10F can discharge approximately 30 liters of pumped medium for each discharge operation.
- The amount of time required for each discharge operation will be between 3 and 30 seconds, depending on the back pressure and the motive medium pressure. This means that the instantaneous flow through the pumped medium outlet pipe during the discharge operation is between 3.6 and 36 metric tonnes per hour.
- When a flowmeter is to be installed in the pumped medium outlet piping, it should be selected to reflect the intermittent operation and should be sized to accommodate the maximum and minimum instantaneous flow.

Contact TLV for details.

Sizing the Condensate Receiver/Reservoir

When selecting the receiver/reservoir for the PowerTrap, select from among the following 3 conditions:

- (1) When large quantities of flash steam are involved
(For open systems using steam)

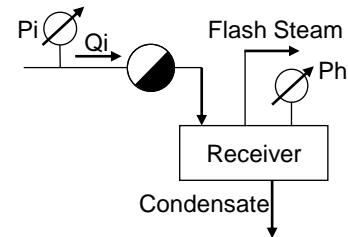

- a) Determine the amount of flash steam:

$$\text{Amount of flash steam } Fs = Q \times (hd' - hh')/r$$

Fs : amount of flash steam (kg/h)

Qi : amount of condensate (kg/h)

hd' : specific enthalpy (kJ/kg) of saturated condensate at condensate inlet set pressure (P_1)

hh' : specific enthalpy (kJ/kg) of saturated condensate at condensate receiver set pressure (P_2)

r : specific enthalpy (kJ/kg) vaporization (latent heat of steam) at condensate receiver set pressure (P_2)

- b) Determine the **vent pipe diameter** according to the amount of flash steam in Vented Receiver Table - 1 shown on the next page.
c) Determine the **overflow pipe diameter** (D_{op} , refer to the figure below).

NOTE: The overflow pipe diameter should be at least as large as the condensate inlet pipe diameter (D_{cip} , refer to the figure below).

- d) Determine the **minimum condensate receiver diameter** (D_{cr} , refer to the figure below) by selecting the largest value among those from (i), (ii), and (iii) based on a condensate receiver length of 1 m.

(i) is the overflow pipe diameter multiplied by 3 or more.

(ii) is the minimum receiver diameter according to the amount of flash steam in Vented Receiver Table - 1 shown on the next page.

(iii) is the minimum receiver diameter according to the amount of condensate in Vented Receiver Table - 2 shown on the next page.

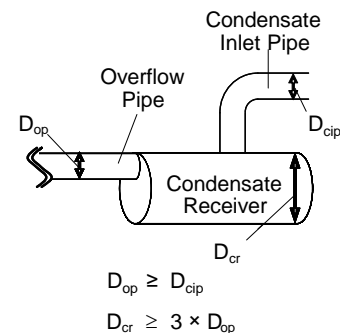

NOTE: Receiver length can be reduced by 50% when the motive pressure (P_m) divided by the back pressure (P_b) is "2" or greater.
(When $P_m \div P_b \geq 2$)

Vented Receiver Table – 1
(For atmospheric, open system installations)

Flash Steam up to ~ kg/hour	Receiver Diameter mm (Length: 1 m)	Vent Line Diameter mm
25	80	25
50	100	50
75	125	50
100	150	80
150	200	80
200	200	100
300	250	125
400	300	125
500	350	150
700	400	200
800	450	200
1000	500	200
1100	500	250
1400	550	250
1500	600	250

Vented Receiver Table – 2
(For atmospheric, open system installations)

Amount of Condensate kg/hour	Receiver Diameter mm (Length: 1 m)
1000 or less	80
1500	100
2000	125
3000	150
6000	200
10000	250

NOTE: When amount of flash steam and condensate are between two values in the table, select the larger value (one line below).

- (2) When flash steam is not involved
(For closed systems)

Determining the reservoir diameter and length based on the amount of condensate:

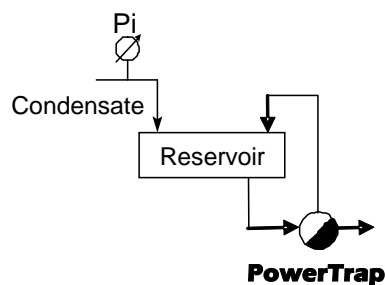

Reservoir Table
(For equalized, closed system installations)

Amount of Pumped Medium (kg/h)	Reservoir Diameter (mm) & Length (m)						
	40	50	80	100	150	200	250
300 or less	1.2m	0.7					
400	1.5	1.0					
500	2.0	1.2	0.5				
600		1.5	0.6				
800		2.0	0.8	0.5			
1000			1.0	0.7			
1500			1.5	1.0			
2000			2.0	1.3	0.6		
3000				2.0	0.9	0.5	
4000					1.2	0.7	
5000					1.4	0.8	0.5
6000					1.7	1.0	0.6
7000					2.0	1.2	0.7
8000						1.3	0.8
9000						1.5	0.9
10000						1.7	1.0

NOTE: Reservoir length can be reduced by 50% when the motive pressure (P_m) divided by the back pressure (P_b) is "2" or greater. (When $P_m \div P_b \geq 2$)

- (3) When there are small quantities of flash steam and a large amount of condensate (e.g., open systems pumping large amounts of super-cooled condensate)

Consult the sizing tables in sections (1) and (2) above.

Select the condensate receiver size based on the larger of (1) and (2).

Select the vent pipe diameter and overflow pipe diameter from (1).

Installing Several PowerTrap Units in Parallel

Refer to the figure below as a general guide for the piping when several PowerTrap units are to be installed after the same pumped medium inlet pipe.

The size of the pumped medium inlet pipe, return line and exhaust pipe manifold is determined by the number of PowerTrap units installed.

When specifications exist separately from the instruction manual, follow the specifications.

NOTE: This sketch is for explanation purposes only and is not intended as an installation design.

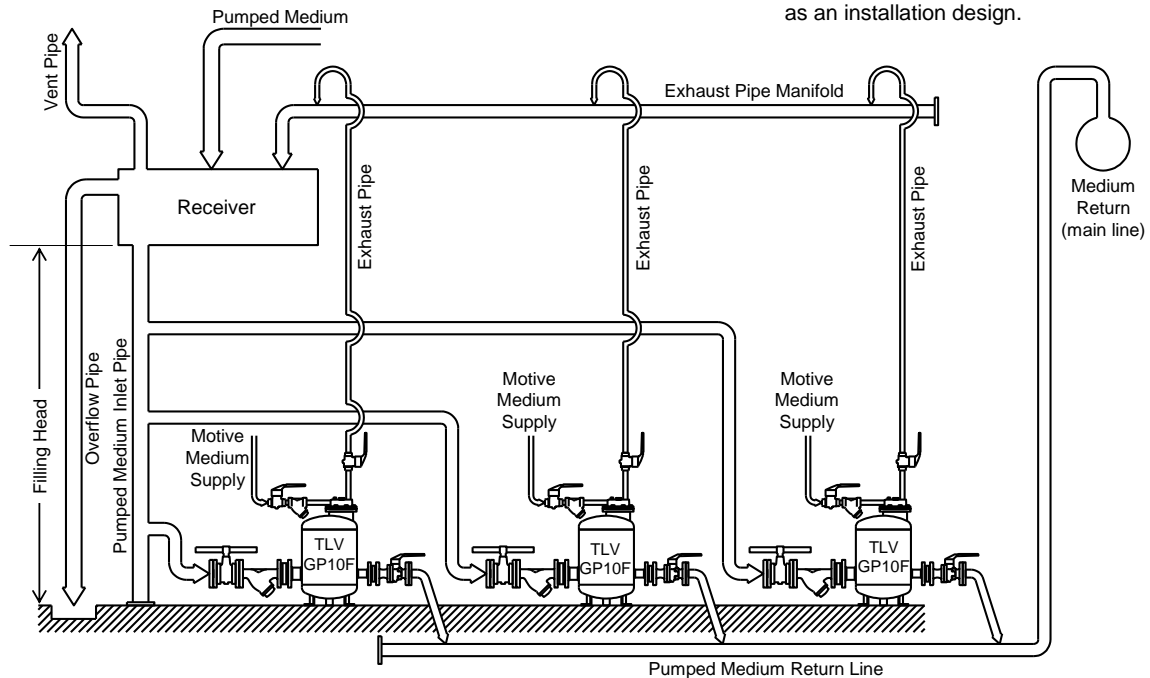

Number of PowerTrap Units Installed	Pumped Medium Inlet Pipe Size	Pumped Medium Return Line Size	Exhaust Pipe Manifold Size	Overflow Pipe Size	Vent Pipe Size
2	125 mm	80 mm	40 mm	Determine overflow pipe size according to "Sizing the Condensate Receiver / Reservoir"	See the Vent Line Diameter column in Table-1
3	150 mm	100 mm	50 mm		
4	200 mm	100 mm	65 mm		
5	200 mm	125 mm	65 mm		
6	200 mm	125 mm	80 mm		

Installation and Maintenance Space

The maintenance space shown in the figure below should be provided to enable disassembly, inspection and replacement of the PowerTrap.

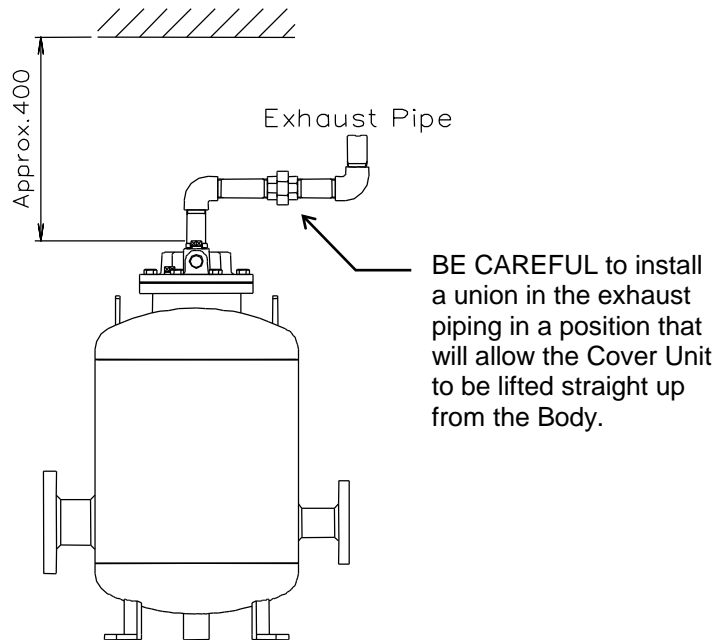
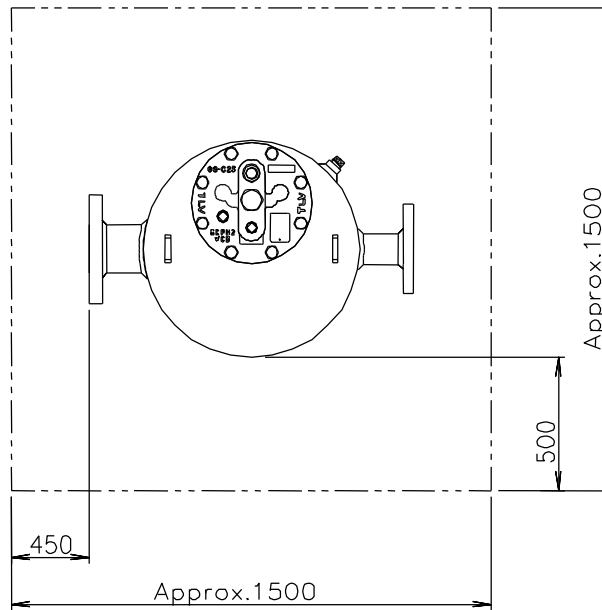

Unit: mm

Operation and Periodic Inspection

WARNING

- After all piping work has been completed in accordance with the specific piping system designed when the decision to utilize the PowerTrap was made, check once again to make sure that all pipe connections have been tightened, gaskets have been inserted where needed and all parts are securely installed.
- When beginning operation, make sure that the operator stays well clear of the release area of the vent line and overflow piping. At the start-up of operation, large quantities of condensate may flow, causing the PowerTrap to momentarily overload. If this occurs in open systems, hot condensate may spurt from the vent piping or overflow piping and could result in burns, other injuries or damage to equipment.

CAUTION

Install properly and **DO NOT** use this product outside the recommended operating pressure, temperature and other specification ranges. Improper use may result in such hazards as damage to the product or malfunctions which may lead to serious accidents. Local regulations may restrict the use of this product to below the conditions quoted.

CAUTION

When disassembling or removing the product, wait until the internal pressure equals atmospheric pressure and the surface of the product has cooled to room temperature. Disassembling or removing the product when it is hot or under pressure may lead to discharge of fluids, causing burns, other injuries or damage.

CAUTION

Be sure to use only the recommended components when repairing the product, and **NEVER** attempt to modify the product in any way. Failure to observe these precautions may result in damage to the product or burns or other injury due to malfunction or the discharge of fluids.

Installation, inspection, maintenance, repairs, disassembly, adjustment and valve opening/closing should be carried out only by trained maintenance personnel.

Operation

(1) Valve Operation

Refer to the open-system piping drawing in “Installation” to become familiar with the names and locations of the various valves.

If water hammer occurs, immediately cease operation and close any valves that are operating.

- Slowly open the valve on the exhaust pipe.
- Slowly open the valve on the motive medium supply pipe.
Make sure that there is no sound of flow from the exhaust pipe or the pumped medium inlet pipe.
- Slowly open the valve on the pumped medium outlet pipe.
- Slowly open the valve on the pumped medium inlet pipe.
When using a manual valve for venting air on a closed system, leave the valve slightly open until the PowerTrap has cycled 2 or 3 times in order to release any air inside the system, then close the valve.

- e) The PowerTrap operation is normal if it cycles intermittently; first exhausting the motive medium to fill with pumped medium, then taking in motive medium to force the pumped medium out.
- The interval of operation will vary greatly depending on the amount of pumped medium inflow, the temperature, the motive medium (steam or gas) and the motive pressure. (The interval of operation is considered to be the length of time between the start of one discharge cycle and the start of the next discharge cycle.)
The interval of operation T_c (s) can be roughly determined using the following formula:

$$T_c = 108,000/Q$$

$$Q: \text{ amount of condensate (inflowing pumped medium) (kg/h)}$$
 - The GP10F can discharge approximately 30 liters of pumped medium for each discharge operation. The amount of time required for each discharge operation will be between 3 and 30 seconds, depending on the back pressure and the motive medium pressure.
- (2) If an error such as a leak or water hammer occurs after beginning PowerTrap operation, shut off the valves immediately in the following order:
valve on motive medium supply pipe → pumped medium inlet valve → pumped medium outlet valve → valve on exhaust pipe
- (3) Whenever any type of malfunction is suspected in the PowerTrap, refer to the “Troubleshooting” section.

Periodic Inspection and Diagnosis

There are two types of periodic inspection: the visual inspection and the disassembly inspection.

(1) Visual Inspection

- As a general rule, this inspection should be performed at least once every 3 months.
- Check the following items:
 - a) There should be no leakage from the PowerTrap or from any of the connections.
 - b) The PowerTrap unit should be operating cyclically (one indication being the sharp, mechanical sound of the snap-unit operating at the transition between the filling and the discharge parts of the cycle). Immediately after the end of the discharge part of the cycle and during the filling part of the cycle, the sound of flow in the exhaust pipe should be heard. During the pumping (discharge) part of the cycle, flow in the motive medium supply pipe should be heard.
 - c) Pumped medium should not accumulate in the (steam-using) equipment, and the temperature of the equipment should not be abnormally low.
 - d) For open systems, verify that an overflow pipe from the receiver is installed.
 - e) For open systems, no steam should be seen flowing out through the vent pipe.
 - f) There should not be any abnormal noise from the pumped medium outlet pipe or the pumped medium recovery line when the PowerTrap operates.

(2) Disassembly Inspection

- Refer to the “Disassembly/Reassembly” section.
- As a general rule, this inspection should be performed at least once every 2 years.
- When inspecting the interior of the unit, check the following items:
 - a) Make sure the push rod does not catch on anything during snap-action (the up-down movement of the push rod) and moves smoothly as the float rises and falls.
 - b) Make sure the valve shafts in the intake (motive medium) and exhaust valves move up and down smoothly. The gap between the stem of the closed intake (motive medium) valve and the push plate should be within the specified range (2 ± 0.3 mm). The exhaust valve will have some movement when open, but should be stable when closed.)
 - c) Make sure the float is not damaged and has not filled with water.
 - d) Make sure all nuts and bolts are properly installed and fastened.
 - e) Check to make sure that there is no foreign matter sticking to the shafts and levers of any of the units, and make sure there is no abnormal wear.
- When reassembling, be sure to replace the body and cover gaskets with new gaskets.
- Also replace any parts that are broken or show serious wear.

Disassembly/Reassembly



NEVER apply direct heat to the float. The float may explode due to increased internal pressure, causing accidents leading to serious injury or damage to property and equipment.



Use hoisting equipment for heavy objects (weighing approximately 20 kg or more). Failure to do so may result in back strain or other injury if the object should fall.



When disassembling or removing the product, wait until the internal pressure equals atmospheric pressure and the surface of the product has cooled to room temperature. Disassembling or removing the product when it is hot or under pressure may lead to discharge of fluids, causing burns, other injuries or damage.



Do not use excessive force when connecting threaded pipes to the product. Over-tightening may cause breakage leading to fluid discharge, which may cause burns or other injury.

Use the procedures on the following pages to remove components. Use the same procedures in reverse to reassemble.



(Installation, inspection, maintenance, repairs, disassembly, adjustment and valve opening/closing should be carried out only by trained maintenance personnel.)

In cases where sufficient maintenance space has been provided for (see the “Installation and Maintenance Space” section), maintenance can be carried out without disconnecting the inlet and outlet piping. Where there is insufficient maintenance space, first disconnect the inlet and outlet piping, and then move the unit to a spacious area in which maintenance can be carried out safely.

When reassembling:

- Be sure to replace the body and cover gaskets with new gaskets. Also replace any parts that are broken or show serious wear.
- When reassembling, coat threads and bolts with anti-seize. Tighten the cover bolts in a symmetrically alternating pattern, being careful to avoid uneven tightening.
- If drawings or other special documentation were supplied for the product, any torque given there takes precedence over values shown here.

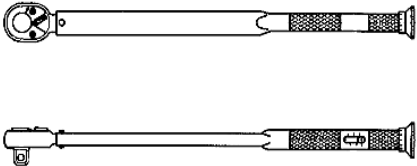
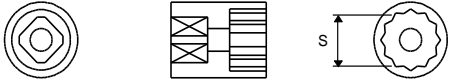
Recommended Tools List for Disassembly/Reassembly

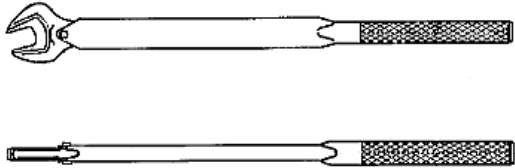
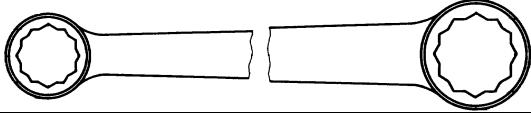
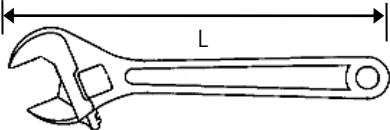
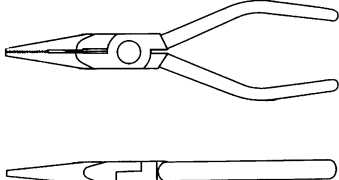
No.	Tool Name	Step Used	Tool
1	Torque Wrench (Ratchet) 80 – 180 N·m	1 5 6	
2	Sockets Distance across flats = S 17 mm → 160 N·m 22 mm → 80 N·m 27 mm → 160 N·m 38 mm → 160 N·m	6 1 5 6	
3	Extension Bar L = 150 mm	6	
4	Open-end Torque Wrench 60 – 100 N·m 22 mm → 100 N·m 22 mm → 60 N·m	3 7	
5	Offset Wrench 22 mm 27 mm	1, 3 5	
6	Adjustable Wrench L = 300 mm max. span = 34 mm	1 7	
7	Needle-Nose Pliers	2 4 6	

(1 N·m ≈ 10 kg·cm)

NOTE: If drawings or other special documentation were supplied for the product, any torque given there takes precedence over values shown here.

1. Removing/Reattaching the Cover Unit

Part	Disassembly	Reassembly
Drain Plug (if present)	<ul style="list-style-type: none"> Using an adjustable wrench slowly loosen plug to release pressure and discharge fluid; take care to avoid being burned by fluid discharge. 	<ul style="list-style-type: none"> Wrap threads with 3 – 3.5 turns of sealing tape or apply sealing compound. Tighten to a torque of 30 N·m.
Cover Bolts	<ul style="list-style-type: none"> Using a 22 mm socket wrench, loosen each bolt slowly one turn in an alternating diagonal pattern. Once all bolts have been loosened, verify that there is no internal pressure before completely removing the bolts. 	<ul style="list-style-type: none"> Reverse steps in disassembly. Tighten to a torque of 80 N·m.
Cover Unit Note: All internal components are attached to the cover unit	<ul style="list-style-type: none"> Disconnect the motive medium supply piping and the exhaust piping from the cover unit (utilize unions in the piping if present). Make sure to secure sufficient space above the cover unit to allow it to be lifted straight up. The cover unit weighs 12.7 kg; take any appropriate measures to assist in its removal. When removing the cover unit, be careful not to bang or damage the float or other internal components. If disassembly of the cover unit is required, support the cover unit securely on a rack that allows access to the components suspended below. 	<ul style="list-style-type: none"> Reverse steps in disassembly.
Cover Gasket	<ul style="list-style-type: none"> Remove only if warped or damaged. 	<ul style="list-style-type: none"> Replace with a new gasket if damaged.

(1 N·m ≈ 10 kg·cm)

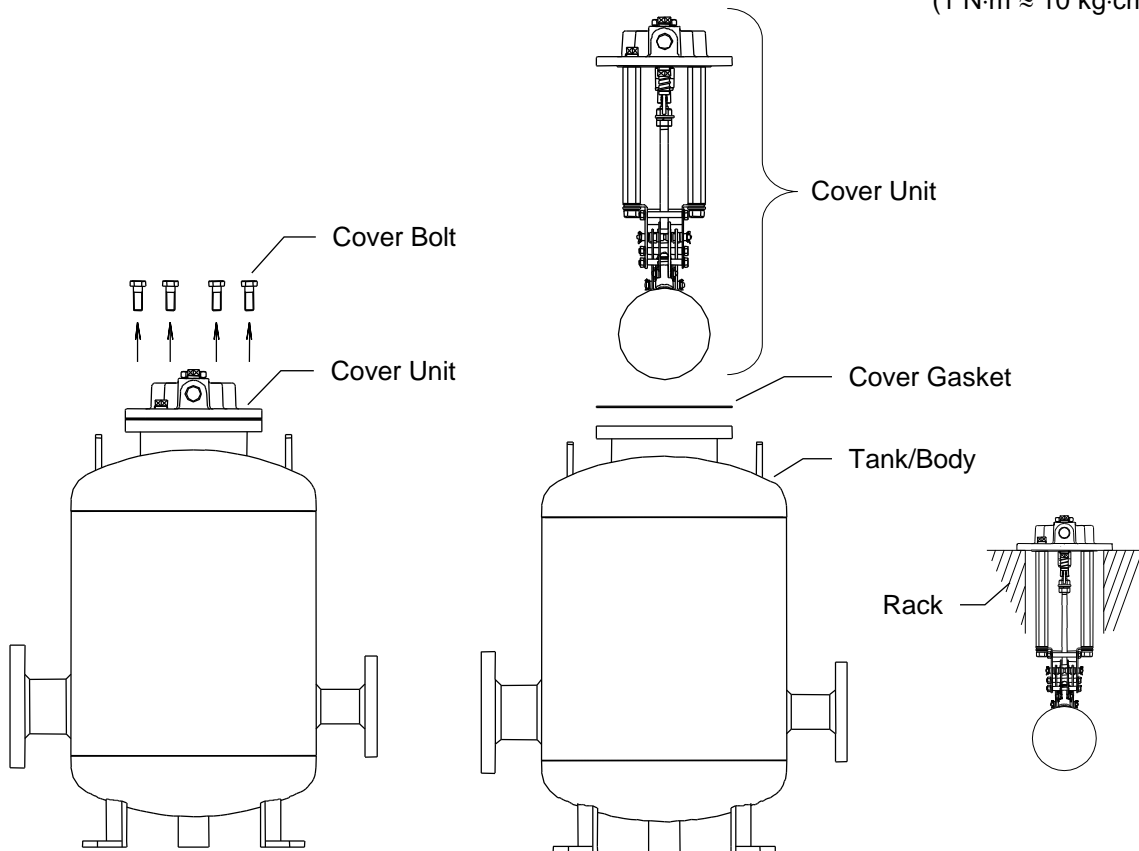

Note: Configuration of tank/body may differ slightly.

2. Removing/Reattaching the Float

It is not necessary to remove the float if only the intake (motive medium) and exhaust valves are to be serviced or replaced. It is not always necessary to replace the float when replacing the snap-action unit. The float should be replaced only when there are irregularities such as damage to its exterior or condensate found inside the float.

Part	Disassembly	Reassembly
Float	<ul style="list-style-type: none"> Using needle-nose pliers, remove the split pin from one side of the connecting pin; remove the exposed flat washer Holding the float to prevent it from falling, remove the connecting pin; be careful not to lose the flat washers. Remove the float; be careful not to damage. 	<ul style="list-style-type: none"> Reverse the steps to reassemble. Use a new split pin if the old one was damaged during disassembly.

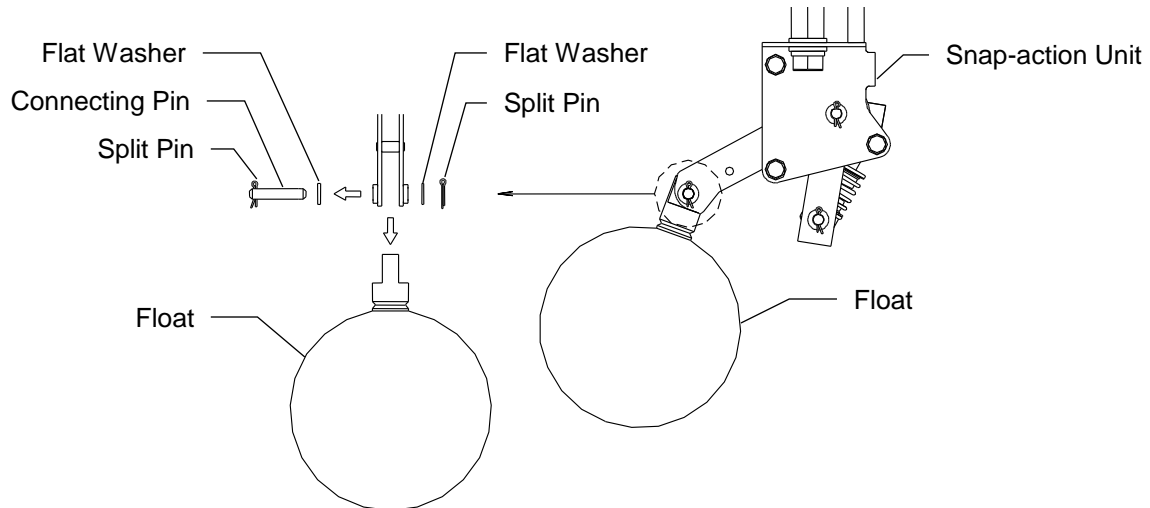

3. Removing/Reattaching the Snap-action Unit

It is not necessary to remove the float before removing the snap-action unit. When working with the snap-action unit, take care not to pinch fingers, etc.

Part	Disassembly	Reassembly
Bolts	<ul style="list-style-type: none"> Using a 22 mm open-ended torque wrench, loosen the two bolts that hold the snap-action to the supports under the cover unit Holding the snap-action unit to prevent it from falling, remove the bolts; be careful not to lose the washers. 	<ul style="list-style-type: none"> Assemble the bolts, spring washers and flat washers, then finger-tighten. Tighten to a torque of 100 N·m.
Snap-Action Unit	<ul style="list-style-type: none"> Remove the snap-action unit (with attached exhaust valve), be careful not to lose the flat washers 	<ul style="list-style-type: none"> Move snap-action unit into place while guiding the exhaust valve into cover unit; align the bolt holes in the snap-action unit with supports; place a flat washer between the snap-action unit and each support.

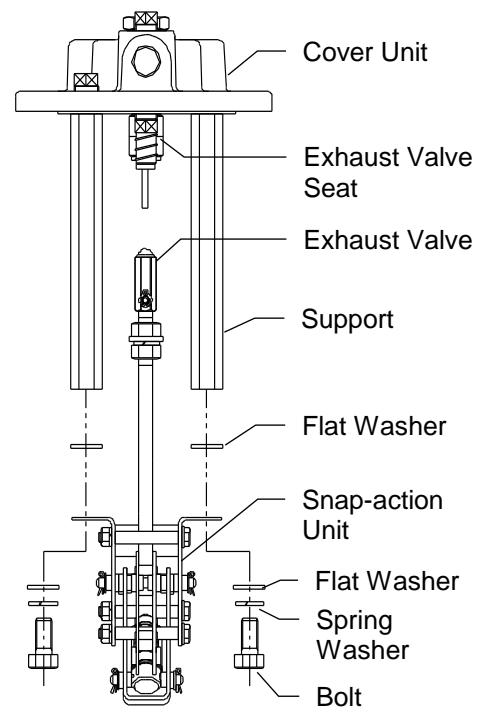

(1 N·m \approx 10 kg·cm)

4. Removing/Reinstalling the Exhaust Valve

Part	Disassembly	Reassembly
Exhaust Valve	<ul style="list-style-type: none"> Using needle-nose pliers, remove the split pin from one side of the connecting pin; remove the exposed flat washer. Remove the connecting pin; be careful not to lose the flat washers. Lift the exhaust valve off of the top of the snap-action unit 	<ul style="list-style-type: none"> Reverse the steps to reassemble. Use a new split pin if the old one was damaged during disassembly. Fold the legs of the split pin completely so that they are wound around the connection pin.

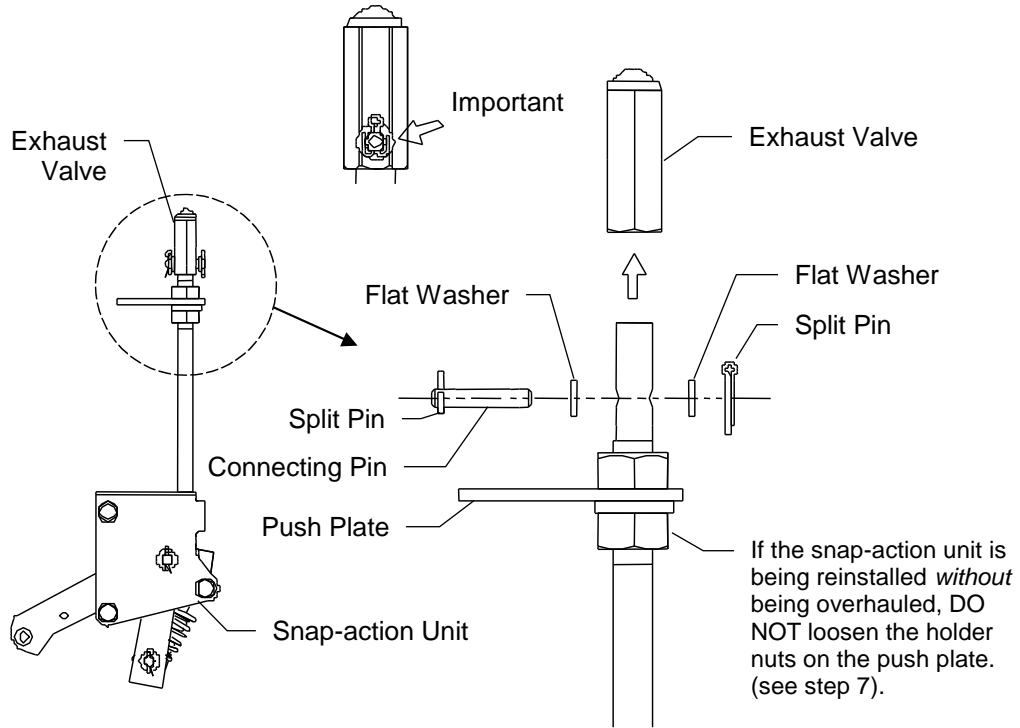

5. Removing/Reinstalling the Exhaust Valve Seat

Part	Disassembly	Reassembly
Exhaust Valve Seat	Using a 27 mm socket wrench, remove the exhaust valve seat from the cover unit	Tighten to a torque of 160 N·m.
Exhaust Valve Seat Gasket	Remove gasket and clean sealing surfaces on the exhaust valve seat and the cover unit	Replace with a new gasket

(1 N·m ≈ 10 kg·cm)

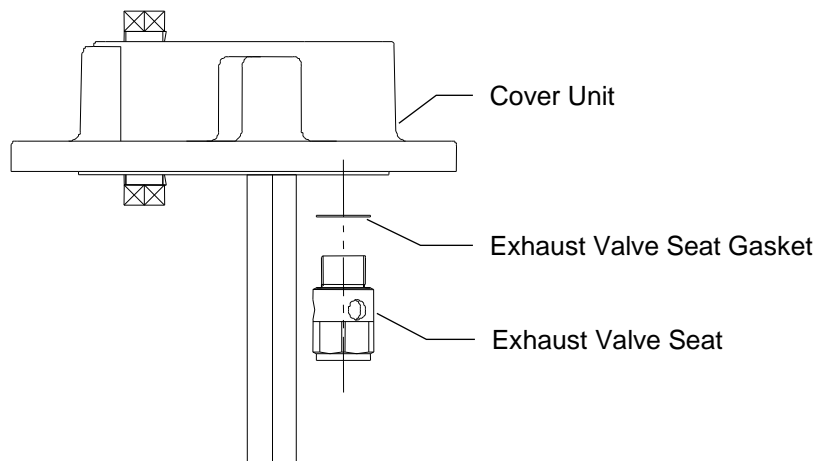

6. Removing/Reinstalling the Motive Medium Intake Valve and Valve Seat

The following procedure can be used to remove and replace the intake (motive medium) valve without first removing the cover of the PowerTrap.

Part	Disassembly	Reassembly
Plug	• Using a 38 mm socket wrench, remove the plug.	• Tighten to a torque of 160 N·m.
Plug Gasket	• Remove gasket and clean sealing surfaces on the plug and the cover.	• Replace with a new gasket.
Motive Medium Intake Valve	• Remove with needle-nose pliers	• Replace with new if damaged.
Screen	• Remove with needle-nose pliers	• Replace with new if damaged.
Motive Medium Intake Valve Seat	• Using a 17 mm socket wrench with an extension bar, loosen the valve seat. • Using needle-nose pliers, grasp and remove the valve seat.	• Using needle-nose pliers, insert the valve seat. • Tighten to a torque of 160 N·m
Motive Medium Intake Valve Seat Gasket	• Remove gasket with needle-nose pliers and clean sealing surfaces.	• Replace with a new gasket.

(1 N·m ≈ 10 kg·cm)

NOTE: It is possible to remove and replace the intake valve (motive medium) without first removing the cover of the PowerTrap (see instructions above).

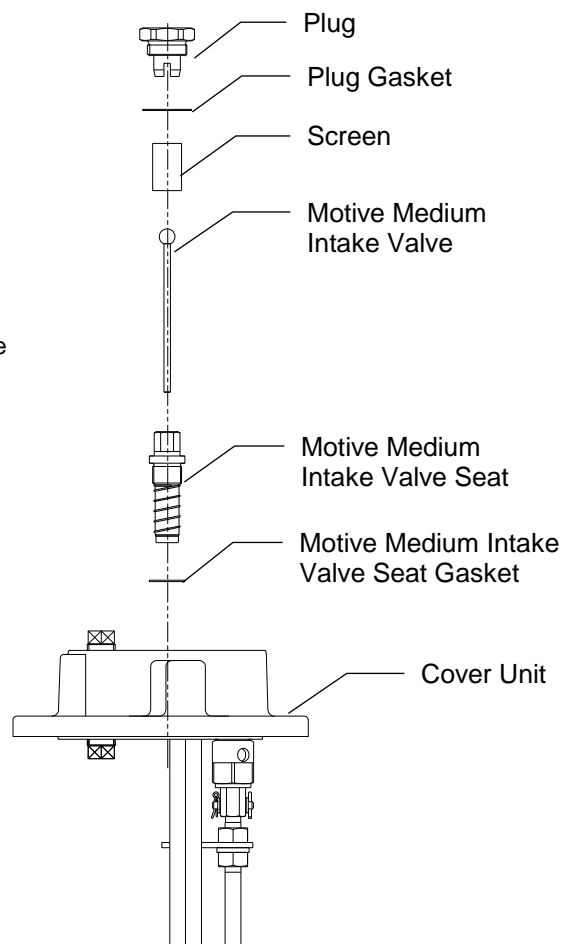

7. Checking/Adjusting the Gap between the Push Plate and the Motive Medium Intake Valve

It is necessary to inspect the gap to determine whether adjustment is necessary **only** when installing a new snap-action unit or an overhauled snap-action unit (from this or another PowerTrap). A feeler (go/no-go) gauge is supplied with each GP10F and replacement snap-action unit.

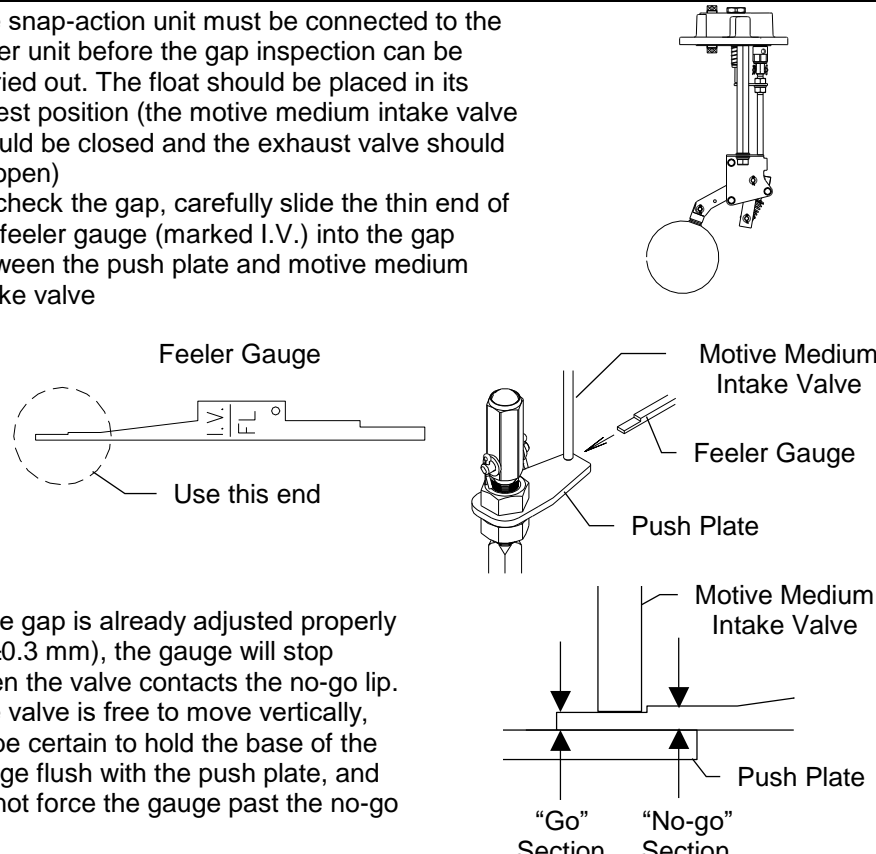
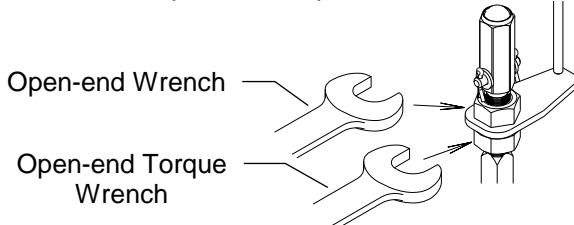
Step	Procedure
<p>Check the Gap Between the Push Plate and the Motive Medium Intake Valve</p>	<ul style="list-style-type: none"> The snap-action unit must be connected to the cover unit before the gap inspection can be carried out. The float should be placed in its lowest position (the motive medium intake valve should be closed and the exhaust valve should be open) To check the gap, carefully slide the thin end of the feeler gauge (marked I.V.) into the gap between the push plate and motive medium intake valve  <p>The diagram shows a side view of the assembly with a feeler gauge inserted between the push plate and the motive medium intake valve. Labels include: Feeler Gauge, Motive Medium Intake Valve, Push Plate, and Feeler Gauge. Below this, a cross-sectional view shows the 'Go' Section (where the gauge fits) and the 'No-go' Section (where the gauge does not fit). Another diagram shows the feeler gauge with a dashed circle around the thin end, labeled 'Use this end'.</p> <ul style="list-style-type: none"> If the gap is already adjusted properly (2 ± 0.3 mm), the gauge will stop when the valve contacts the no-go lip. The valve is free to move vertically, so be certain to hold the base of the gauge flush with the push plate, and do not force the gauge past the no-go lip.
<p>Adjusting the gap between the push plate and the motive medium intake valve</p>	<ul style="list-style-type: none"> When a snap-action unit that has been removed from the cover is reinstalled without being overhauled, do not loosen the holder nuts from the push plate. If the previous inspection reveals that the gap is out of the accepted range (2 ± 0.3 mm), proceed with gap adjustment. Loosen the push plate holder nuts with two 22 mm wrenches, one an open-end wrench, the other an open-end torque wrench.  <p>The diagram shows a top-down view of the push plate assembly. Two wrenches are shown: an open-end wrench and an open-end torque wrench. Labels include: Open-end Wrench and Open-end Torque Wrench.</p> <ul style="list-style-type: none"> Set the position with the upper nut, then finger-tighten the lower nut. Recheck the gap with the feeler gauge. When the clearance is correct, hold the upper nut steady with the open-end wrench and tighten the lower nut with the open-end torque wrench to a torque of 60 N·m. Recheck the gap and, if necessary, repeat the adjustment procedure.

(1 N·m \approx 10 kg·cm)

Troubleshooting



WARNING

NEVER apply direct heat to the float. The float may explode due to increased internal pressure, causing accidents leading to serious injury or damage to property and equipment.



CAUTION

DO NOT OPERATE the PowerTrap with piping disconnected. When it is absolutely necessary to operate with a portion of the outlet piping removed in order to examine an operational failure, open the motive medium and condensate inlet valves slowly, standing a safe distance from the open pipe section until the safety of this action is confirmed.



CAUTION

When disassembling or removing the product, wait until the internal pressure equals atmospheric pressure and the surface of the product has cooled to room temperature. Disassembling or removing the product when it is hot or under pressure may lead to discharge of fluids, causing burns, other injuries or damage.

When the desired performance is not attained with the system, in many cases it is due to the following:

- (1) Loose chips from pipe cutting and tapping, welding scraps or sealant, which catch in the intake valve (motive medium) or check valve and prevent them from closing/operating properly.
- (2) Changes in the amount of condensate inflow, motive pressure or back pressure that are in excess of the original design.

Since successful operation of the PowerTrap system depends on proper design and installation of the system, investigate the entire system to locate the source of problems when they occur. When no source can be identified, inspect the PowerTrap and take whatever action is necessary.

Determining the Problem from the Symptoms

Use the “Types of Failure and their Causes” table on the following page to determine the cause of the problem from the type of abnormality that has occurred. Apply the corrective measures listed in the “Causes and Corrective Measures” table.

Types of Failure and their Causes

Detailed explanations of the meanings of the numbers listed in the “Types of Failure” column are found in the “Causes and Corrective Measures” table.

	Has the PowerTrap operated at least once?	Has pumped medium collected in the PowerTrap?	Is there a continuous flowing sound from the motive medium supply pipe?	Is there a continuous flowing sound from the exhaust pipe?	Types of Failure (Category A – G) and Corrective Measures (Causes 1 – 6)							
					A	B	C	D	E	F	G	
PowerTrap Does Not Operate	NO	NO	NO	NO	1,2,3			1			3	
		YES	YES	YES					1			
	NO	NO	NO	NO	1,4			1,2				
		YES	YES	YES							1	
	YES	NO	NO	NO		2			1			
		YES	YES	YES						2	1	
	YES	NO	NO	NO					1			
		YES	YES	YES							3	
	YES	NO	NO	NO						3,4		
		YES	YES	YES								1
PowerTrap Operates	Has the pumped medium accumulated in the receiver and backed up in the equipment?						2	1,2,3,4			2,4	1
	Is there any abnormal noise from the check valves?						3					
	Is there any abnormal noise from the pumped medium outlet pipe?						4					
	Is steam escaping from the exhaust pipe or receiver?											

Causes and Corrective Measures

Category	Cause	Procedure
A. A valve on the pipeline is closed	<ol style="list-style-type: none"> 1. The valve on the motive medium supply pipe is closed 2. The valve on the exhaust pipe is closed 3. The valve on the condensate inlet pipe is closed 4. The valve on the condensate outlet pipe is closed 	- Slowly open the valve, using the proper procedure
B. The strainer is clogged	<ol style="list-style-type: none"> 1. The strainer on the motive medium supply pipe is clogged 2. The strainer on the pumped medium inlet pipe is clogged 	- Clean the strainer
C. Faulty motive medium pressure, back pressure or pumped medium inlet pressure	1. The motive medium supply pressure is less than the back pressure	<ul style="list-style-type: none"> - When the motive medium pressure is decreasing, adjust the pressure reducing valve on the supply pipe or connect to a separate high-pressure line - If the back pressure has increased, check to see if a steam trap connected to the pumped medium recovery line is blowing (see Open System Piping Diagram) and check for any valves that have been left closed on the pumped medium recovery line - The motive medium pressure must be about 0.5 bar (0.05 MPa) higher than the back pressure (see (2) in the "Installation Procedure" section)
	2. Insufficient motive medium	- If the motive medium supply pipe is too small; change to a larger size pipe; the pipe should be at least 20 mm
	3. The pumped medium inlet pressure exceeds the back pressure (see G.1.)	<ul style="list-style-type: none"> - When the pumped medium inlet pressure exceeds the back pressure, "blowthrough" occurs (i.e., steam flows into the pumped medium outlet pipe); in some cases, chattering on the outlet check valve or water hammer may also occur - The same thing will occur when the back pressure has decreased in a closed system - Check the reason that the pumped medium inlet pressure has increased or the back pressure has decreased and make any necessary repairs
	4. Motive medium supply pressure is too high	<ul style="list-style-type: none"> - If the motive medium supply pressure is twice the back pressure or greater, "blowby" occurs, i.e., residual pressure at the end of the motive medium supply process flows into the outlet pipe; when the temperature of the pumped medium in the recovery pipe is low, water hammer may also occur - The motive medium supply pressure should be reduced to a range within which the discharge flow does not drop below the required level

Category	Cause	Procedure
D. Faulty piping	1. The exhaust is abnormal	<ul style="list-style-type: none"> - Air binding or vapor locking has occurred; in the case of a closed system, the exhaust pipe is connected to the reservoir, but the pumped medium may not be exchanged for the medium inside the PowerTrap for the following reasons: <ul style="list-style-type: none"> (1) There is a U-shaped pipe between the exhaust port and the receiver (2) The exhaust pipe has a diameter of less than 25 mm (3) There is no air vent for steam on top of the reservoir or the steam equipment If (1), (2), or (3): Change the pipe or install an air vent - The distance from the ground to the highest point on the exhaust pipe is too great (over 3 m); add a steam trap to the exhaust pipe at a point just above where the exhaust pipe exits the body of the unit
	2. The filling head is insufficient 3. The pumped medium inlet pipe is too small 4. Not enough pumped medium is flowing through the pumped medium inlet valve	<ul style="list-style-type: none"> - Normal pumped medium flow will not be obtained if the filling head is smaller than that in the original design; the recommended filling head is 1070 mm - Normal pumped medium flow may not be obtained if the pumped medium inlet pipe is too small or the valve on the pumped medium inlet pipe is a needle valve or one with a small Cv value - The pipe and stop valve size must be increased to the design pipe size, and a full bore ball valve or gate valve must be used
E. Faulty PowerTrap	1. Dirt or scale is caught in the motive medium intake valve or the valve is worn 2. Dirt or scale is caught in the exhaust valve or the valve is worn 3. The snap-action unit is obstructed by dirt or scale or its operation is otherwise faulty 4. The float is broken	<ul style="list-style-type: none"> - The PowerTrap does not operate for long periods of time, in spite of the fact that pumped medium has collected in the receiver/reservoir; if there is no sound at all of the operating medium flowing in the motive medium intake valve and the exhaust valve, it is possible that the PowerTrap is faulty. Note, however, that this phenomenon will also occur when the motive medium pressure is less than the back pressure - If the PowerTrap does not operate for long periods of time and the sound of the operating medium can be heard continuously in the motive medium supply pipe, the PowerTrap is faulty - Disassemble the PowerTrap, and inspect the following items: <ul style="list-style-type: none"> (1) Raise and lower the float and check to make sure the snap-action unit operates properly (2) Check the motive medium intake and exhaust valves to make sure there is no dirt or scale caught or any other abnormality (3) Check other possible factors that might hinder operation <p>After performing the above inspection, repair any defects discovered or replace the PowerTrap</p>

Category	Cause	Corrective Measure
F. Faulty check valve	1. Dirt or scale is caught in the pumped medium inlet check valve or the valve is worn or getting hung up	- The operating medium that has been supplied is leaking from the inlet check valve, preventing the pressure inside the trap from increasing; as a result, the pumped medium is not discharged Disassembly and inspection is required
	2. Dirt or scale is caught in the pumped medium outlet check valve or the valve is worn or getting hung up	- The discharged pumped medium has flowed back into the PowerTrap, causing the interval at which the unit operates to grow shorter and reducing its discharge capacity Disassembly and inspection is required
	3. The pumped medium inlet or outlet check valves have been installed in the wrong direction	- Correct the installation so that the check valve is facing the right way to allow the desired flow of pumped medium
	4. The pumped medium inlet or outlet check valves are too small	- The pumped medium flow capacity is insufficient Use a larger size
G. There is a problem with other equipment	1. A large quantity of steam is flowing into the receiver	- When a large quantity of steam is discharged from the exhaust pipe or vent pipe, it may be because steam from a blowing steam trap or an open valve has flowed into the pumped medium inflow pipe system of the receiver; check these traps and the valves on the pumped medium inflow pipe system

Product Warranty

1. Warranty Period
One year following product delivery.
2. Warranty Coverage
TLV CO., LTD. warrants this product to the original purchaser to be free from defective materials and workmanship. Under this warranty, the product will be repaired or replaced at our option, without charge for parts or labor.
3. This product warranty will not apply to cosmetic defects, nor to any product whose exterior has been damaged or defaced; nor does it apply in the following cases:
 - 1) Malfunctions due to improper installation, use, handling, etc., by other than TLV CO., LTD. authorized service representatives.
 - 2) Malfunctions due to dirt, scale, rust, etc.
 - 3) Malfunctions due to improper disassembly and reassembly, or inadequate inspection and maintenance by other than TLV CO., LTD. authorized service representatives.
 - 4) Malfunctions due to disasters or forces of nature.
 - 5) Accidents or malfunctions due to any other cause (such as water hammer) beyond the control of TLV CO., LTD.
4. Under no circumstances will TLV CO., LTD. be liable for consequential economic loss damage or consequential damage to property.

Service

For Service or Technical Assistance: Contact your TLV representative or your TLV office.

In Europe:

TLV EURO ENGINEERING GmbH

Daimler-Benz-Straße 16-18, 74915 Waibstadt, **Germany**

Tel: [49]-(0)7263-9150-0
Fax: [49]-(0)7263-9150-50

TLV EURO ENGINEERING UK LTD.

Star Lodge, Montpellier Drive, Cheltenham, Gloucestershire, GL50 1TY, **U.K.**

Tel: [44]-(0)1242-227223
Fax: [44]-(0)1242-223077

TLV EURO ENGINEERING FRANCE SARL

Parc d'Ariane 2, bât. C, 290 rue Ferdinand Perrier, 69800 Saint Priest, **France**

Tel: [33]-(0)4-72482222
Fax: [33]-(0)4-72482220

In North America:

TLV CORPORATION

13901 South Lakes Drive, Charlotte, NC 28273-6790, **U.S.A.**

Tel: [1]-704-597-9070
Fax: [1]-704-583-1610

In Mexico and Latin America:

TLV ENGINEERING S. A. DE C. V.

Av. Jesús del Monte 39-B-1001, Col. Hda. de las Palmas, Huixquilucan, Edo. de México, 52763, **Mexico**

Tel: [52]-55-5359-7949
Fax: [52]-55-5359-7585

In Oceania:

TLV PTY LIMITED

Unit 8, 137-145 Rooks Road, Nunawading, Victoria 3131, **Australia**

Tel: [61]-(0)3-9873 5610
Fax: [61]-(0)3-9873 5010

In East Asia:

TLV PTE LTD

36 Kaki Bukit Place, #02-01/02, **Singapore** 416214

Tel: [65]-6747 4600
Fax: [65]-6742 0345

TLV SHANGHAI CO., LTD.

Room 5406, No. 103 Cao Bao Road, Shanghai, **China** 200233

Tel: [86]-(0)21-6482-8622
Fax: [86]-(0)21-6482-8623

TLV ENGINEERING SDN. BHD.

No.16, Jalan MJ14, Taman Industri Meranti Jaya, 47120 Puchong, Selangor, **Malaysia**

Tel: [60]-3-8065-2928
Fax: [60]-3-8065-2923

TLV PRIVATE LIMITED

252/94 (K-L) 17th Floor, Muang Thai-Phatra Complex Tower B, Rachadaphisek Road, Huaykwang, Bangkok 10310, **Thailand**

Tel: [66]-2693-3799
Fax: [66]-2693-3979

TLV INC.

#302-1 Bundang Technopark B, 723 Pangyo-ro, Bundang, Seongnam, Gyeonggi, 13511, **Korea**

Tel: [82]-(0)31-726-2105
Fax: [82]-(0)31-726-2195

In the Middle East:

TLV ENGINEERING FZCO

Building 6WA, Office No. 629, PO Box 371684, Dubai Airport Free Zone, Dubai, **UAE**

Tel: [971]-(0)4-399-3641
Fax: [971]-(0)4-399-3645

In Other Countries:

TLV INTERNATIONAL, INC.

881 Nagasuna, Noguchi, Kakogawa, Hyogo 675-8511, **Japan**

Tel: [81]-(0)79-427-1818
Fax: [81]-(0)79-425-1167

Manufacturer:

TLV CO., LTD.

881 Nagasuna, Noguchi, Kakogawa, Hyogo 675-8511, **Japan**

Tel: [81]-(0)79-422-1122
Fax: [81]-(0)79-422-0112