



PowerTrap®

MODEL GT10M CAST IRON CAST STEEL

COMPACT MECHANICAL PUMP WITH STEAM TRAP FOR CONDENSATE REMOVAL AND RECOVERY

Features

Pump/Trap with built-in steam trap for a wide range of applications: drainage of low capacity heat exchangers, flash steam recovery systems and reservoirs, often operating under vacuum conditions.

1. Handles high temperature condensate without cavitation.
2. No electric power or additional level controls required, hence INTRINSICALLY SAFE.
3. Pump will operate with a low filling head (min. 300 mm).
4. Easy, inline access to internal parts simplifies cleaning and reduces maintenance costs.
5. High quality stainless steel internals and hardened working surfaces ensure reliability.
6. Compact design permits installation in a limited space.



Specifications

Model		GT10M
Connection	Pumped Medium Inlet & Outlet	Flanged*
	Motive Medium & Pump Exhaust	Screwed
Size	Pumped Medium: Inlet x Outlet	DN 40 x DN 25
	Motive Medium Inlet	1/2"
	Pump Exhaust Outlet	1/2"
Maximum Operating Pressure (barg)	PMO	10.5
Maximum Operating Temperature (°C)	TMO	185
Motive Medium Pressure Range (barg)		0.3 – 10.5
Maximum Allowable Back Pressure		0.5 bar less than motive medium pressure used
Volume of Each Discharge Cycle (ℓ)		approximately 7.5
Motive Medium**		Saturated Steam
Pumped Medium***		Steam Condensate, Water

* For details of flange connection, see picture at bottom right ** Do not use with toxic, flammable or otherwise hazardous fluids. 1 bar = 0.1 MPa
 *** Do not use for fluids with specific gravities under 0.85 or over 1, or for toxic, flammable or otherwise hazardous fluids.

PRESSURE SHELL DESIGN CONDITIONS (NOT OPERATING CONDITIONS):
 Maximum Allowable Pressure (barg) PMA: 13 (Cast Iron), 21 (Cast Steel)
 Maximum Allowable Temperature (°C) TMA: 200 (Cast Iron), 220 (Cast Steel)

CAUTION To avoid abnormal operation, accidents or serious injury, DO NOT use this product outside of the specification range. Local regulations may restrict the use of this product to below the conditions quoted.

No.	Description	Material	DIN*	ASTM/AISI*
①	Body	Cast Iron FC250	0.6025	A126 Cl.B
		Cast Steel** A216 Gr.WCB	1.0619	—
②	Cover	Cast Iron FC250	0.6025	A126 Cl.B
		Cast Steel** A216 Gr.WCB	1.0619	—
③	Cover Gasket	Graphite Compound	—	—
④	Float	Stainless Steel SUS316L	1.4404	AISI316L
⑤	Snap-action Unit	Stainless Steel	—	—
⑥	Intake Valve	Stainless Steel SUS440C	1.4125	AISI440C
	Valve Seat	Stainless Steel SUS420F	1.4028	AISI420F
⑦	Exhaust Valve	Stainless Steel SUS440C	1.4125	AISI440C
	Valve Seat	Stainless Steel SUS420F	1.4028	AISI420F
⑧	Steam Trap Unit	Stainless Steel	—	—
⑨	Inlet Check Valve CKF5M	Stainless Steel SUS304	1.4301	AISI304
⑩	Outlet Check Valve CKF3M	Cast Stainless Steel A351 Gr.CF8	1.4312	—

* Equivalent materials ** Option: Cast Stainless Steel

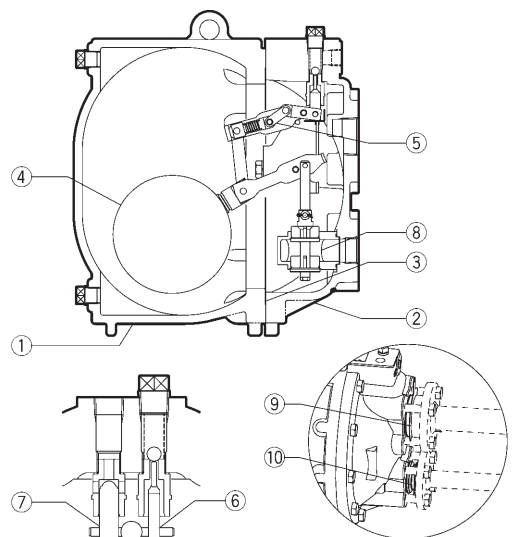

Dimensions

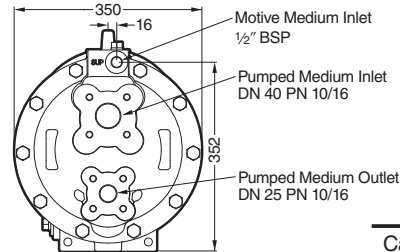
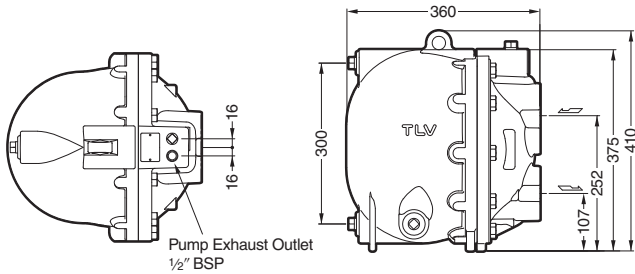

Units: mm

Weight (kg)	
Cast Iron	56
Cast Steel	61

Note: All Plug Holes 1/2" BSP

Discharge Capacity

Connection:	Flanged
Inlet size:	DN 40
Outlet size:	DN 25
Check Valve:	
Inlet (CKF5M):	DN 40
Outlet (CKF3M):	DN 25
Filling Head:	630 mm

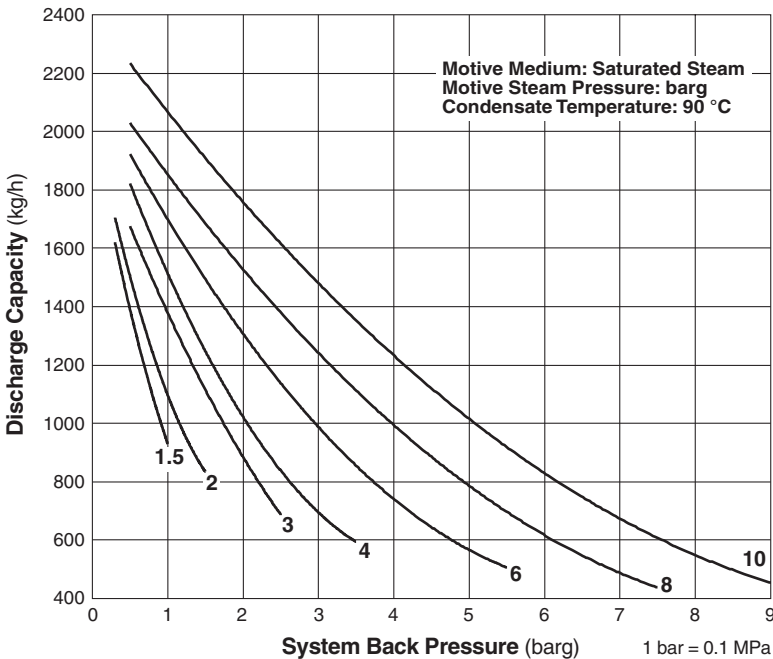

NOTE:

- A check valve must be installed at both the pumped medium inlet and outlet. To achieve the above capacities with the standard GT10M configuration, TLV check valves CKF5M for inlet and CKF3M for outlet must be used.
- Motive steam pressure minus back pressure must be greater than 0.5 bar.
- A strainer must be installed at the motive medium and pumped medium inlets.

• **Correction Factor**

For GT10M installed with filling head other than 630 mm
(minimum filling head: 300 mm)

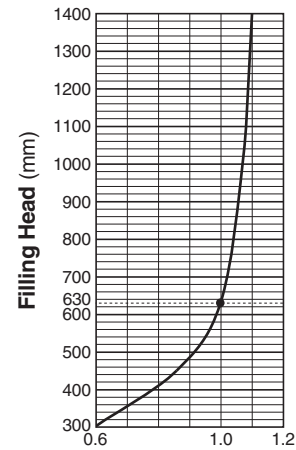

• **Illustration of Filling Head and Pressures**

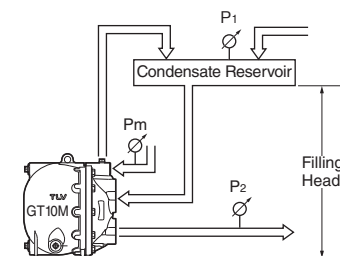

- The discharge capacity is determined by the motive medium, motive medium pressure (P_m) and back pressure (P_2).

Make sure that:
 $\text{Discharge Capacity} \times \text{Correction Factor} > \text{Required Flow Rate}$

Size of Reservoir

The reservoir must have a capacity sufficient to store the condensate produced during the PowerTrap operation and discharge.

Size of Reservoir (flash steam is not involved)

Amount of Condensate (kg/h)	Reservoir Diameter (mm) and Length (m)						
	40	50	80	100	150	200	250
300 or less	1.2m	0.7					
400	1.5	1.0					
500	2.0	1.2	0.5				
600		1.5	0.6				
800		2.0	0.8	0.5			
1000			1.0	0.7			
1500			1.5	1.0			
2000			2.0	1.3	0.6		
3000				2.0	0.9	0.5	
4000					1.2	0.7	
5000					1.4	0.8	0.5
6000					1.7	1.0	0.6
7000					2.0	1.2	0.7
8000						1.3	0.8
9000						1.5	0.9
10000						1.7	1.0

Reservoir length can be reduced by 50% when the motive medium pressure (Pm) divided by back pressure (P2) equals 2 or greater (when $P_m \div P_2 \geq 2$).

Steam Consumption (Motive Medium)

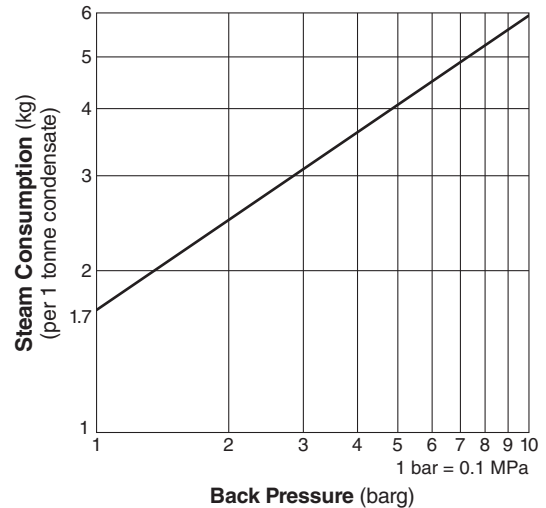

GT10M Steam Trap Discharge Capacity

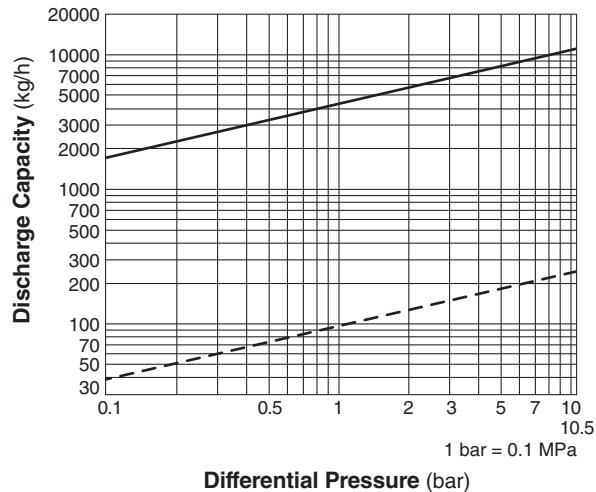

- : Capacity of GT10M as a steam trap ($P_1 > P_2$). Instantaneous condensate loads above the rated trap capacity will cause the pump to cycle and therefore reduce the discharge capacity.
- - - : Minimum amount of condensate required to prevent steam leakage.

1. Capacities are based on continuous discharge of condensate 6 °C below steam temperature.
2. Differential pressure is the difference between inlet and outlet pressure of the trap.



DO NOT use this product under conditions that exceed maximum differential pressure, as condensate backup will occur!

Memo:

Manufacturer

ISO 9001/ISO 14001

TLV® CO., LTD.
Kakogawa, Japan

is approved by LRQA Ltd. to ISO 9001/14001

