



FREE FLOAT[®] STEAM TRAP

MODEL SS5-P Clean Steam Trap

STAINLESS STEEL FREE FLOAT STEAM TRAP FOR PURE AND CLEAN STEAM SYSTEMS

Features

Free float steam trap recommended for use in reactors, fermenters and sterilizers in the chemical, pharmaceutical, food and beverage services.

1. Virtually crevice-free design with drain hole allows for condensate drainage without pooling, minimizing the possibility of bacteria build-up.
2. Internal buff-polishing with an additional interior and exterior electro-polish option to $0.4\mu\text{m}$ Ra for improved resistance to bacterial growth.
3. Self-modulating free float provides continuous, smooth, low-velocity discharge as process loads vary.
4. Maintainable design lowers cleaning costs.
5. Only one moving part, the free float, eliminates valve wear and provides long service life.



Specifications

Model	SS5-P*	
Connection**	Clamp End	
Size	25, 38 mm (ISO) 1", 1 1/2" (ASME-BPE)	
Maximum Operating Pressure (MPaG) PMO	0.6	
Maximum Differential Pressure (MPa) ΔPMX	0.6	
Maximum Operating Temperature (°C) TMO	165	
Finishing (Internal/External)*	0.8 μm Ra buff-polished / Bead-blasted and electro-polished	

* SS5-EP with $0.4\mu\text{m}$ Ra internal and external electro-polishing available on request ** Tube End connections available on request 1 MPa = 10.197 kg/cm²
PRESSURE SHELL DESIGN CONDITIONS (NOT OPERATING CONDITIONS): Maximum Allowable Pressure (MPaG) PMA: 1.0
Maximum Allowable Temperature (°C) TMA: 185

CAUTION To avoid abnormal operation, accidents or serious injury, DO NOT use this product outside of the specification range. Local regulations may restrict the use of this product to below the conditions quoted.

No.	Description	Material	JIS	ASTM/AISI
①	Body	Cast Stainless Steel	—	A351 Gr. CF3M
②	Cover	Cast Stainless Steel	—	A351 Gr. CF3M
③	Float	Stainless Steel	SUS316L	AISI316L*
④	Body Clamp	Cast Stainless Steel	—	A351 Gr. CF8
⑤	Clamp Gasket**	High-performance Fluorine Resin	—	—

* Equivalent

** Clamp gasket is GYLON BIO-PRO; complies with FDA 21 CFR 177. 1550, USP Class VI and EN 1935. GYLON BIO-PRO is a registered trademark of Garlock GmbH.

Material certificates to ISO10474 2.2 or 3.1.B available for major components, contact TLV for details

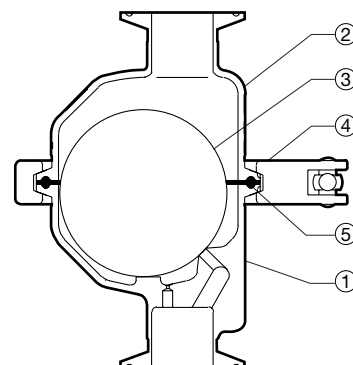

Dimensions

● **SS5-P** Clamp End

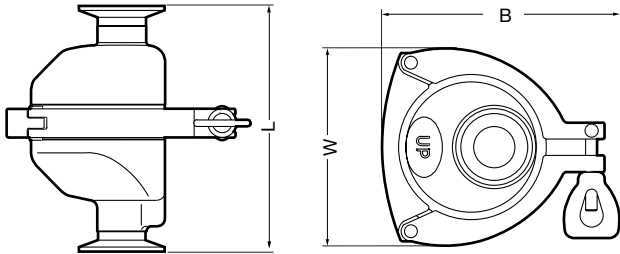

SS5-P Clamp End*

Size	L	W**	B**	φD	φd	Weight (kg)
25 (1")	145	115	140	50.5	22.6 (22.1)	1.7
38 (1½")					35.6 (34.8)	

* ISO 2852 Clamp / ISO 2037 Tube or ASME-BPE (Tri-Clamp compatible)
 ** Approximate dimensions
 () ASME-BPE (Tri-Clamp compatible)

● **SS5-P** Clamp End Connections

ISO 2852 Clamp / ISO 2037 Tube

ASME-BPE (Tri-Clamp Compatible)

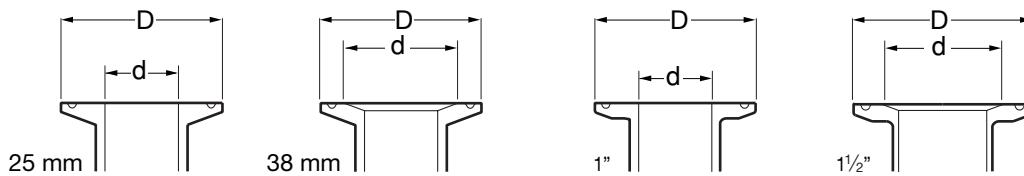

Discharge Capacity

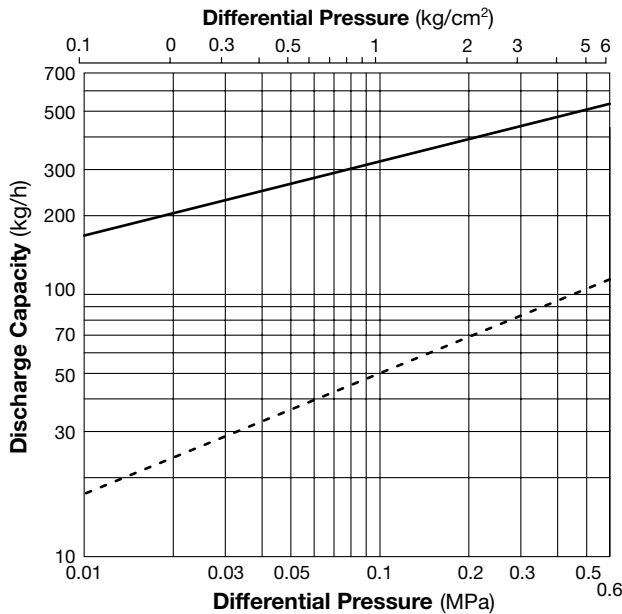

— : Maximum capacity of SS5-P
 - - - : Minimum amount of condensate required to prevent steam discharge

1. Differential pressure is the difference between the inlet and outlet pressure of the trap.
2. Capacities are based on continuous discharge of condensate 6 °C below saturated steam temperature.
3. Recommended safety factor: at least 1.5.

CAUTION DO NOT use traps under conditions that exceed maximum differential pressure, as condensate backup will occur!

The SS5-P **Clean Steam Trap** has a small built-in drain hole to ensure no condensate remains in the trap after operation. Therefore, a minimum condensate load is required during operation to prevent any steam discharge. The chart below shows the maximum steam discharge through the drain hole under no condensate load conditions.

Max. Steam Discharge Through Drain Hole (no condensate load)

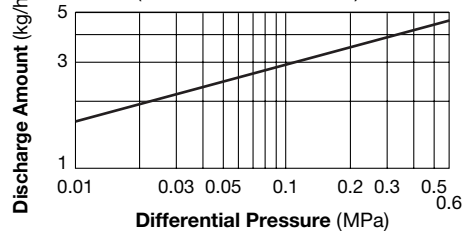

Manufacturer

TLV® CO., LTD.

Kakogawa, Japan

is approved by LRQA Ltd. to ISO 9001/14001

ISO 9001/ISO 14001

