



BELLOWS SEALED GLOBE VALVE

MODEL **BE8H** CAST IRON, DUCTILE CAST IRON
CAST STEEL, STAINLESS STEEL

GLOBE-TYPE VALVE WITH BELLOWS SEALED STEM

Features

Two-port durable bellows sealed shut-off globe valve for steam, water and other fluids*.

1. Durable stem with bellows seal and gland.
2. Non-rotating stem and non-rising hand wheel with position indication.
3. Plug and seat ring made of stainless steel.
4. Free of asbestos, PCB and CFC.

* Do not use for toxic, flammable or otherwise hazardous fluids.

Pressure Equipment Directive (PED)



This product fully conforms to the requirements of the Pressure Equipment Directive (PED, 2014/68/EU) and features CE marking where applicable.

Specifications



Model	BE8H-16	BE8H-25	BE8H-40	
Body Material	Cast Iron EN-GJL-250	Ductile Cast Iron EN-GJS-400-18-LT	Cast Steel GP240GH	Cast Stainless Steel G-X5CrNiMo19-11-2
Connection	Flanged PN 16	Flanged PN 25	Flanged PN 40	
Size	DN 15 to 200*	DN 15 to 200	DN 15 to 200	

* Other sizes available on request

Operating Pressure & Temperature

Model	-60	-20	-10	50	100	120	150	200	250	300	350	400	450	Temperature (°C)
BE8H-16	—	—	16	16	16	16	14.4	12.8	11.2	9.6	—	—	—	Maximum Operating Pressure (barg)
BE8H-25	—	—	25	25	25	25	24.3	23	21.8	20	17.5	—	—	
BE8H-40	Cast Steel	—	30	40	40	—	35.2	33.3	30.4	27.6	25.7	23.8	13.1	
	Cast Stainless Steel	40	40	40	40	40	—	36.3	33.7	31.8	29.7	28.5	27.4	—



To avoid abnormal operation, accidents or serious injury, DO NOT use this product outside of the specification range. Local regulations may restrict the use of this product to below the conditions quoted.

No.	Description	Material	DIN*		
①	Body	BE8H-16	Cast Iron EN-GJL-250	0.6025	
		BE8H-25	Ductile Cast Iron EN-GJS-400-18-LT	0.7043	
		BE8H-40	Cast Steel	Cast Steel GP240GH	1.0619
②	Seat Ring Seat	BE8H-16, BE8H-25	Stainless Steel X12Cr13	1.4006	
		BE8H-40	G 19 9 L Si	1.4021	
③	Bonnet	BE8H-16, BE8H-25	Ductile Cast Iron EN-GJS-400-18-LT	0.7043	
		BE8H-40	Cast Steel	Cast Steel GP240GH	1.0619
			Stainless Steel	Cast Stainless Steel GX5CrNiMo19-11-2	1.4408
④	Stem	BE8H-16, BE8H-25	Stainless Steel X20Cr13	1.4021	
		BE8H-40	Cast Steel	Stainless Steel X20Cr13	1.4021
			Stainless Steel	Austenitic Stainless Steel X6CrNiMoTi17-12-2	1.4571
⑤	Disk	BE8H-16, BE8H-25	Stainless Steel X20Cr13+QT	1.4021	
		BE8H-40	Cast Steel	Stainless Steel X20Cr13+QT	1.4021
			Stainless Steel	Austenitic Stainless Steel X6CrNiMoTi17-12-2	1.4571
⑥	Bellow	Austenitic Stainless Steel X6CrNiMoTi17-12-2	1.4571		
⑦	Handwheel	Steel	—		
⑧	Sleeve	11SMnPb30	—		
⑨	Hexagon Bolt	BE8H-16	5.6	—	
		BE8H-25	A2-70	—	
	Stud Bolt, Nut Bolt, Nut	BE8H-40	Cast Steel	25CrMo4	—
			Stainless Steel	A4-70	—
⑩	Gland Packing	Graphite	—		
⑪	Bonnet Gasket	BE8H-16, BE8H-25	Graphite + CrNiSt	—	
		BE8H-40	Graphite	—	

* Equivalent materials

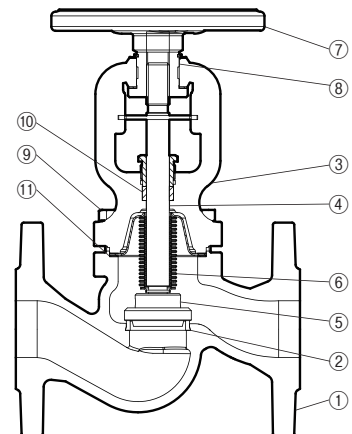

BE8H-16, BE8H-25

Dimensions

● **BE8H-16 / BE8H-25** Flanged

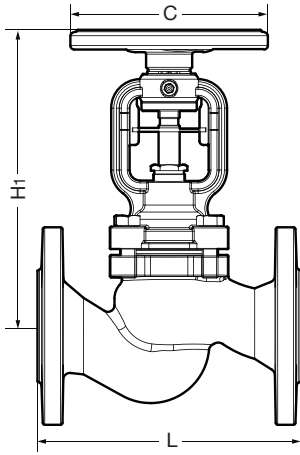

BE8H-16 / BE8H-25 Flanged (mm)

DN	L		H1	φ C	Weight (kg)
	DIN EN 1092-2	PN 16/25			
15	130		178	125	3.2
20	150				3.9
25	160				4.85
32	180				6.5
40	200		150	150	9.0
50	230				11
65	290		175		15.8
80	310		200		24.3
100	350		250		35
125	400		300		49
150	480		400		76
200	600		500		130.5

● **BE8H-40** Flanged

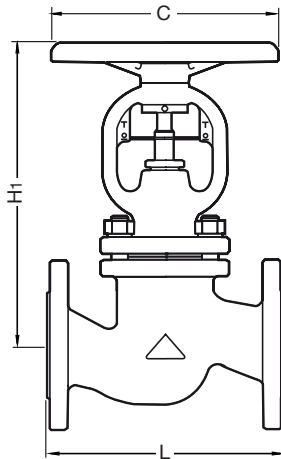

BE8H-40 Flanged (mm)

DN	L		H1	φ C	Weight (kg)	
	DIN EN 1092-1	PN 40			Cast Steel	Cast Stainless Steel
15	130		190	125	4.3	3.8
20	150				5.1	4.9
25	160				6.0	5.7
32	180		195		7.6	7.4
40	200		240	200	11.5	10.7
50	230				13.7	13.1
65	290		270	250	20.1	19.5
80	310		300		27.5	25.7
100	350		450	300	44.0	43.9
125	400		520		65.5	64.8
150	480		570		110.0	95.0
200	600		627	400	172.5	152.0

Balancing disc for size > DN100

Cv & Kvs Values

Model	DN	15	20	25	32	40	50	65	80	100	125	150	200
BE8H-16 BE8H-25	Kvs (DIN)	5.9	7.4	13	18	30	41	79	115	181	225	364	725
	Cv (UK)	5.7	6.8	13	18	29	40	77	112	176	219	354	705
	Cv (US)	6.9	8.2	15	21	35	48	92	134	211	263	425	846
BE8H-40	Kvs (DIN)	6.0	8.7	15.5	25.3	28.8	46.5	76.4	113	180	238	358	552
	Cv (UK)	5.8	8.4	15	24.5	27.9	45.1	74.2	110	175	232	348	536
	Cv (US)	7.0	10.1	18	29.5	33.6	54.2	89.1	132	210	278	417	644

Manufacturer
TLV CO., LTD.
Kakogawa, Japan
is approved by LRQA Ltd. to ISO 9001/14001

