



# FREE FLOAT<sup>®</sup> STEAM TRAP

## MODEL JH8R-X/JH8R-B CAST STEEL

### FREE FLOAT STEAM TRAP WITH THERMOSTATIC AIR VENTING

#### Features

A reliable and durable cast steel\* steam trap for use on large-size process equipment. JH8R-B is also suitable for high-pressure process equipment.

1. Self-modulating free float provides continuous, smooth, low-velocity condensate discharge as process loads vary.
2. Constant water seal design ensures a steam-tight seal, even under low-load conditions.
3. **JH8R-X**: Thermostatic capsule (X-element) with “fail open” feature vents air automatically at close-to-steam temperature.
4. **JH8R-B**: Thermostatic bimetal air vent valve vents air automatically for rapid startup.
5. Built-in screen with large surface area ensures extended trouble-free operation.
6. Easy, inline access to internal parts simplifies cleaning and reduces maintenance costs.

\* Stainless Steel body available on request



#### Specifications

Model	JH8R-X		JH8R-B	
	Socket Welded	Flanged	Socket Welded	Flanged
Connection	Socket Welded	Flanged	Socket Welded	Flanged
Size	DN 50, 80, 100		DN 50, 80, 100	
Orifice No.	0.5, 2, 5, 10, 14, 22, 32		0.5, 2, 5, 10, 14, 22, 32, 40, 46	
Maximum Operating Pressure (barg) PMO	0.5, 2, 5, 10, 14, 22, 32		0.5, 2, 5, 10, 14, 22, 32, 40, 46	
Maximum Differential Pressure (bar) ΔPMX	0.5, 2, 5, 10, 14, 22, 32		0.5, 2, 5, 10, 14, 22, 32, 40, 46	
Maximum Operating Temperature (°C) TMO	240		400*/425	
Type of Air Vent	X-element (6 °C subcooling)		Bimetal (vents air up to approx. 100 °C)	

PRESSURE SHELL DESIGN CONDITIONS (NOT OPERATING CONDITIONS):

Maximum Allowable Pressure (barg) PMA: 40 (JH8R-X), 46 (JH8R-B)

Maximum Allowable Temperature (°C) TMA: 400\*/425

\* With PN flange

1 bar = 0.1 MPa



To avoid abnormal operation, accidents or serious injury, DO NOT use this product outside of the specification range. Local regulations may restrict the use of this product to below the conditions quoted.

No.	Description	Material	DIN*	ASTM/AISI*
①	Body	Cast Steel A216 Gr.WCB	1.0619	—
②	Cover	Carbon Steel A105	1.0460	—
③ <sup>F</sup>	Float	Stainless Steel SUS316L	1.4404	AISI316L
④ <sup>R</sup>	Orifice	—	—	—
⑤ <sup>MR</sup>	Orifice Gasket	Soft Iron SUYP	1.1121	AISI1010
⑥ <sup>MR</sup>	Outlet Cover Gasket	Graphite/Stainless Steel SUS304	-/1.4301	-/AISI304
⑦ <sup>R</sup>	Screen	Stainless Steel SUS430	1.4016	AISI430
⑧	Screen Holder	Stainless Steel SUS304	1.4301	AISI304
⑨	Snap Ring	Stainless Steel SUS304	1.4301	AISI304
⑩ <sup>MR</sup>	Cover Gasket	Graphite/Stainless Steel SUS304	-/1.4301	-/AISI304
⑪	Cover Bolt	Alloy Steel SNB16	1.7711	A193 Gr.B16
⑫	Cover Nut	Carbon Steel S45C	1.0503	AISI1045
⑬	Outlet Cover	Stainless Steel SUS420J2	1.4031	AISI420
⑭	Outlet Cover Bolt	Alloy Steel SNB16	1.7711	A193 Gr.B16
⑮	Outlet Cover Nut	Carbon Steel S45C	1.0503	AISI1045
⑯ <sup>RX</sup>	Air Vent Unit**	—	—	—
⑰ <sup>MRX</sup>	Air Vent Unit Gasket	Soft Iron SUYP	1.1121	AISI1010
⑱	Air Vent Guide	Stainless Steel SUS303	1.4305	AISI303
⑲	Nameplate	Stainless Steel SUS304	1.4301	AISI304
⑳ <sup>MR</sup>	Screen Holder Retainer	Stainless Steel SUS304	1.4301	AISI304
㉑	Eye Bolt	Stainless Steel SS400	1.0037	A6
㉒	Socket***	Carbon Steel A105	1.0460	—
	Flange	Cast Steel A216 Gr.WCB	1.0619	—
㉓ <sup>MR</sup>	Drain Plug Gasket	Soft Iron SUYP	1.1121	AISI1010
㉔	Drain Plug	Carbon Steel S25C	1.1158	AISI1025

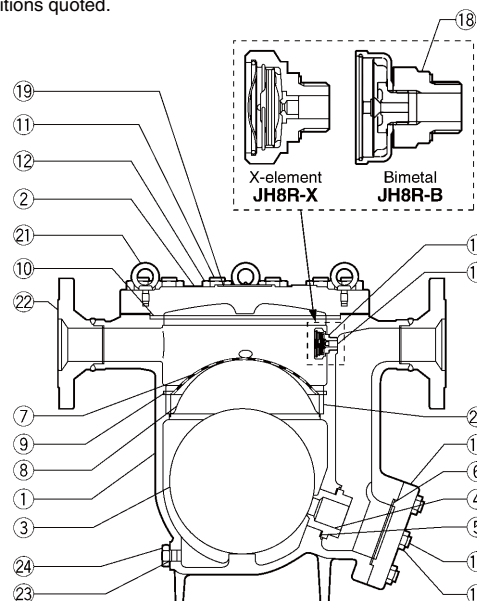

Copyright © TLV

\* Equivalent materials \*\* Replacement kit for air vent unit: Bimetal (R), X-element (X) \*\*\* Shown on reverse  
Replacement kits available: (M) maintenance parts, (R) repair parts, (F) float, (X) X-element unit

**Dimensions**

● **JH8R-X/JH8R-B** Socket Welded

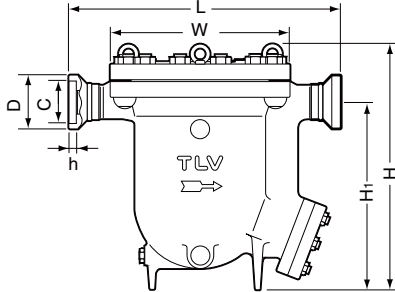

**JH8R-X/JH8R-B** Socket Welded\* (mm)

DN	L	H	H <sub>1</sub>	φW	φD	φC	h	Weight (kg)
50	570	524	400	375	77.5	61.2	16	111
80					112	89.8		118
100	610				140	115.2		124

\* ASME B16.11-2005, other standards available

● **JH8R-X/JH8R-B** Flanged

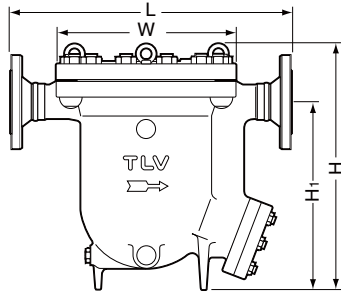

**JH8R-X/JH8R-B** Flanged (mm)

DN	L				H	H <sub>1</sub>	φW	Weight* (kg)
	DIN 2501	ASME Class						
	PN25/40	150RF	300RF	600RF				
50	592	591	597	616	524	400	375	118
80	588	588	598	617				121
100	580	570	596	622				125

Other standards available, but length and weight may vary  
\* Weight is for DIN PN 25/40

**Discharge Capacity**

● **JH8R-X**

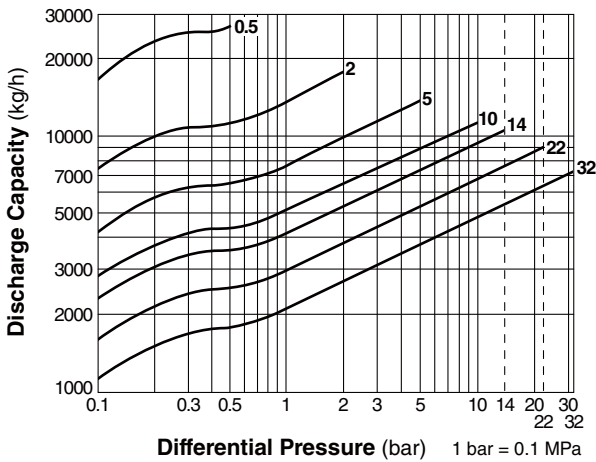

● **JH8R-B**

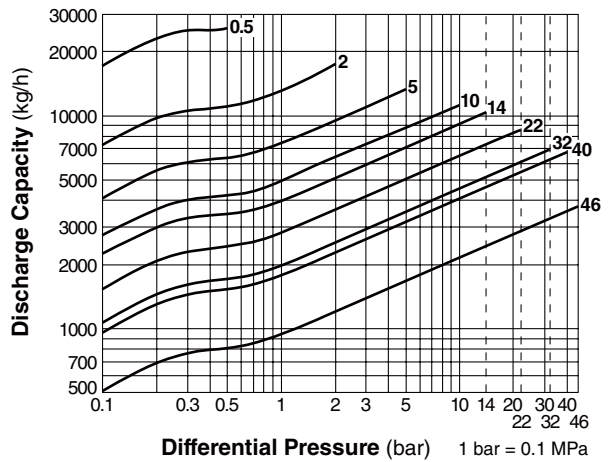

1. Line numbers within the graph are orifice numbers.
2. Differential pressure is the difference between the inlet and outlet pressure of the trap.
3. Capacities are based on continuous discharge of condensate 6 °C below saturated steam temperature.
4. Recommended safety factor: at least 1.5.



DO NOT use traps under conditions that exceed maximum differential pressure, as condensate backup will occur!

Manufacturer

**TLV** CO., LTD.  
Kakogawa, Japan

is approved by LRQA Ltd. to ISO 9001/14001

ISO 9001  
ISO 14001

