



FREE FLOAT® STEAM TRAP

MODEL JH3-X/JH3-B STAINLESS STEEL

FREE FLOAT STEAM TRAP WITH THERMOSTATIC AIR VENTING

Features

A reliable and durable stainless steel steam trap for use on small-size process equipment. JH3-B is also suitable for both superheated and highpressure process equipment.

1. Self-modulating free float provides continuous, smooth, low velocity condensate discharge as process loads vary.
2. Constant water seal and unique three-point seating ensure perfect steam-tight seal, even under no-load conditions.
3. **JH3-X:** Thermostatic capsule (X-element) with "fail open" feature vents air automatically at close-to-steam temperature.
4. **JH3-B:** Thermostatic bimetal air vent valve vents air automatically for rapid startup.
5. Built-in screen with large surface ensures trouble free operation.
6. Easy, inline access to internal parts simplifies cleaning and reduces maintenance costs.



Pressure Equipment Directive (PED)

Classification according to PED 2014/68/EU, fluid group 2

Size	Category	CE marking
DN 15 to DN 25	— *	Art. 4, Sec. 3 (sound engineering practice), CE marking not allowed

* Manufactured in accordance with sound engineering practice

Specifications

Model	JH3-X	JH3-B
Connection	Flanged	Flanged
Size	DN 15, 20, 25	DN 15, 20, 25
Orifice No.	2, 5, 10, 14, 22, 32	2, 5, 10, 14, 22, 32
Maximum Operating Pressure (barg) PMO	2, 5, 10, 14, 22, 32	2, 5, 10, 14, 22, 32
Maximum Differential Pressure (bar) ΔPMX	2, 5, 10, 14, 22, 32	2, 5, 10, 14, 22, 32
Maximum Operating Temperature (°C) TMO	240	350
Type of Air Vent	X-element (6 °C subcooling)	Bimetal (vents air up to approx. 100 °C)

PRESSURE SHELL DESIGN CONDITIONS (NOT OPERATING CONDITIONS): Maximum Allowable Pressure (barg) PMA: 32
Maximum Allowable Temperature (°C) TMA: 350
Minimum Allowable Temperature (°C): -40
1 bar = 0.1 MPa

CAUTION To avoid abnormal operation, accidents or serious injury, DO NOT use this product outside of the specification range. Local regulations may restrict the use of this product to below the conditions quoted.

No.	Description	Material	DIN*	ASTM/AISI*
①	Body	Cast Stainless Steel A351/A351M Gr.CF8 or CF8M	1.4312 or 1.4410	—
②	Cover	Cast Stainless Steel A351/A351M Gr.CF8 or CF8M	1.4312 or 1.4410	—
③ ^F	Float	Stainless Steel SUS316L	1.4404	AISI316L
④	Orifice Plug	Cast Stainless Steel A351/A351M Gr.CF8 or CF8M	1.4312 or 1.4410	—
⑤ ^{MR}	Orifice Plug Gasket	Stainless Steel SUS316L	1.4404	AISI316L
⑥ ^R	Orifice	—	—	—
⑦ ^{MR}	Orifice Gasket	Stainless Steel SUS316L	1.4404	AISI316L
⑧ ^R	Screen inside/outside	Stainless Steel SUS430/304	1.4016/1.4301	AISI430/304
⑨ ^{MR}	Cover Gasket	Graphite/Stainless Steel SUS316L	-/1.4404	-/AISI316L
⑩	Nameplate	Stainless Steel SUS304/SUS316L	1.4301/1.4404	AISI304/AISI316L
⑪ ^R	Float Cover	Stainless Steel SUS304	1.4301	AISI304
⑫ ^R	X-element Guide	Stainless Steel SUS304	1.4301	AISI304
⑬ ^R	X-element	—	—	—
⑭ ^R	Spring Clip	Stainless Steel SUS304	1.4301	AISI304
⑮ ^R	Air Vent Valve Seat	Stainless Steel SUS420F	1.4028	AISI420F
⑯	Connector	Stainless Steel SUS416	1.4005	AISI416
⑰	Cover Bolt	Stainless Steel SUS304 or A193/A193M Gr.B8M	1.4301 or 1.4401	AISI304 or —
⑱ ^R	Air Vent Screen	Stainless Steel SUS304	1.4301	AISI304
⑲ ^R	Snap Ring	Stainless Steel SUS304	1.4301	AISI304
⑳ ^R	Air Vent Valve Plug	—	—	—
㉑ ^R	Air Vent Valve Seat	—	—	—
㉒ ^R	Bimetal Plate	—	—	—
㉓ ^R	Air Vent Case	Cast Stainless Steel A351/A351M Gr.CF8	1.4312	—
㉔	Drain Plug Gasket**	Stainless Steel SUS316L	1.4404	AISI316L
㉕	Drain Plug**	Stainless Steel SUS303	1.4305	AISI303

* Equivalent materials ** Option

Replacement kits available: (M) maintenance parts, (R) repair parts, (F) float

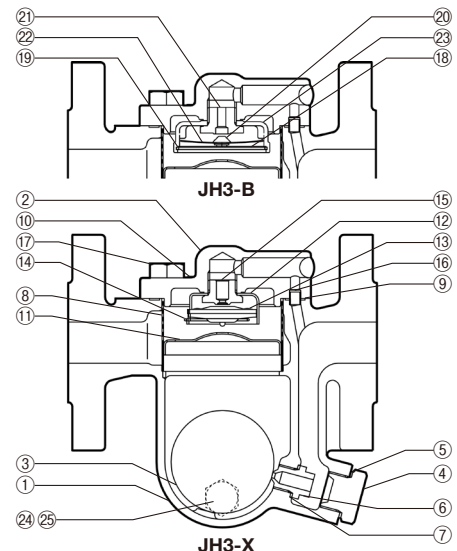

Copyright © TLV

Dimensions

● JH3-X/JH3-B Flanged

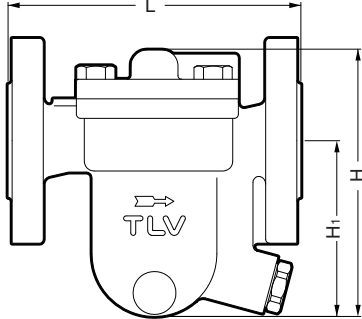

JH3-X/JH3-B Flanged (mm)

DN	L	H	H ₁	Weight (kg)
	DIN 2501 PN25/40			
15	150	132	84	3.4
20		140	90	3.6
25	160	147	92	4.6

Discharge Capacity

● JH3-X

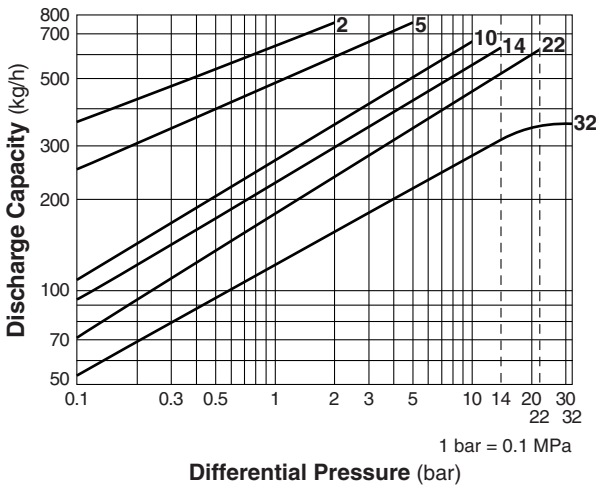

● JH3-B

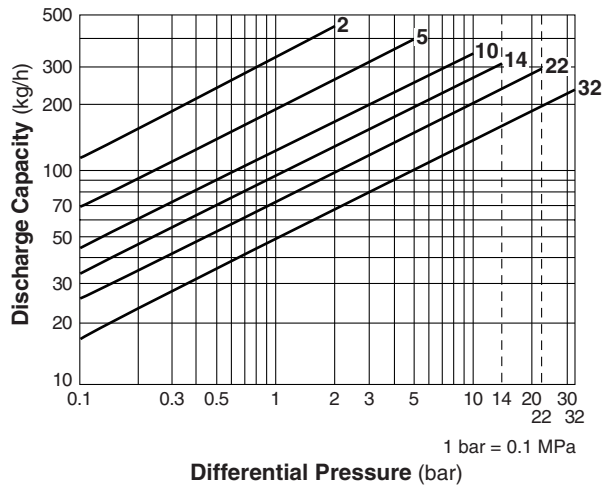

1. Line numbers within the graph refer to orifice numbers.
2. Differential pressure is the difference between the inlet and outlet pressure of the trap.
3. Capacities are based on continuous discharge of condensate 6 °C below saturated steam temperature.
4. Recommended safety factor: at least 1.5.

CAUTION DO NOT use traps under conditions that exceed maximum differential pressure, as condensate backup will occur!

Manufacturer
TLV CO., LTD.
 Kakogawa, Japan
 is approved by LRQA Ltd. to ISO 9001/14001

