



FREE FLOAT STEAM TRAP

MODEL J3S-X

FREE FLOAT STEAM TRAP WITH THERMOSTATIC AIR VENTING

Benefits

An all-stainless steel free float steam trap for increased durability with tight shutoff for use on small to medium-size process equipment.

1. Self-modulating free float provides continuous, smooth, low velocity condensate discharge as process loads vary, for maximum performance.
2. Unique rotational seating design eliminates concentrated wear to provide long life.
3. Thermostatic capsule (X-element) with "fail open" feature vents air automatically until close-to-steam temperature.
4. Easy, inline access to internal parts simplifies cleaning and lowers maintenance costs.
5. Rugged float construction with up to 1740 psig hydraulic shock rating ensures excellent resistance to water hammer.
6. Built-in screen with large surface area ensures extended trouble-free service.

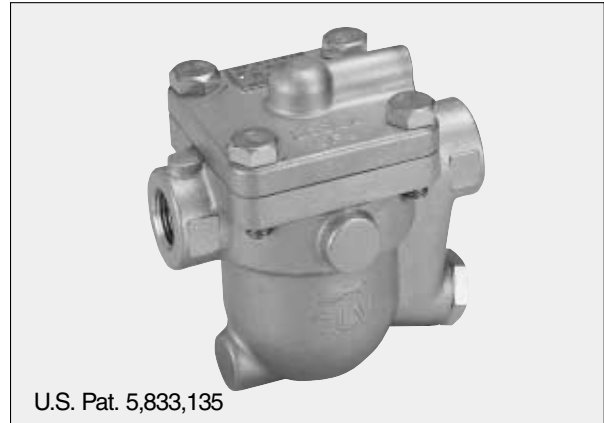

CAUTION DO NOT DISASSEMBLE OR REMOVE THIS PRODUCT WHILE IT IS UNDER PRESSURE. Allow internal pressure of this product to equal atmospheric pressure and its surface to cool to room temperature before disassembling or removing. Failure to do so could cause burns or other injury. READ INSTRUCTION MANUAL CAREFULLY.

Specifications

Model		J3S-X	
Connection		Screwed	Flanged
Size (in)		1/2, 3/4, 1	1/2, 3/4, 1
Orifice No.		2, 5, 10, 14, 21	
Maximum Operating Pressure (psig)	PMO	30, 75, 150, 200, 300	
Maximum Differential Pressure (psi)	Δ PMX	30, 75, 150, 200, 300	
Minimum Operating Pressure (psig)		Vacuum	
Maximum Operating Temperature (°F)	TMO	428	
Maximum Allowable Pressure (psig)	PMA	300	
Maximum Allowable Temperature	TMA	428	

Connections and sizes in bold are standard



To avoid abnormal operation, accidents or serious injury, DO NOT use this product outside of the specification range. Local regulations may restrict the use of this product to below the conditions quoted.

No.	Description	Material	ASTM/AISI*	JIS
①	Body	Cast Stainless Steel	A351 Gr.CF8	—
②	Cover	Cast Stainless Steel	A351 Gr.CF8	—
③ ^F	Float	Stainless Steel	AISI316L	SUS316L
④	Orifice Plug	Cast Stainless Steel	A351 Gr.CF8	—
⑤ ^{MR}	Orifice Plug Gasket	Stainless Steel	AISI316L	SUS316L
⑥ ^R	Orifice	—	—	—
⑦ ^{MR}	Orifice Gasket	Stainless Steel	AISI316L	SUS316L
⑧ ^R	Screen	Stainless Steel	AISI430	SUS430
⑨ ^{MR}	Cover Gasket	Fluorine Resin	PTFE	PTFE
⑩	Nameplate	Stainless Steel	AISI304	SUS304
⑪ ^R	Float Cover	Stainless Steel	AISI304	SUS304
⑫ ^R	X-element Guide	Stainless Steel	AISI304	SUS304
⑬ ^R	X-element	Stainless Steel	—	—
⑭ ^R	Spring Clip	Stainless Steel	AISI304	SUS304
⑮ ^R	Air Vent Valve Seat	Stainless Steel	AISI420F	SUS420F
⑯	Connector	Stainless Steel	AISI416	SUS416
⑰	Cover Bolt	Stainless Steel	AISI304	SUS304
⑱	Flange**	Cast Stainless Steel	A351 Gr.CF8	—
⑲	Drain Plug Gasket***	Stainless Steel	AISI316L	SUS316L
⑳	Drain Plug***	Stainless Steel	AISI303	SUS303

* Equivalent ** Shown on reverse *** Option
Replacement kits available: (M) maintenance parts, (R) repair parts, (F) float

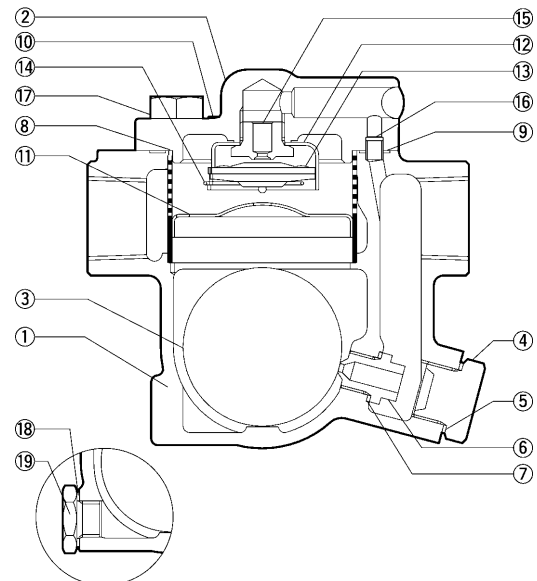

Dimensions

● **J3S-X** Screwed

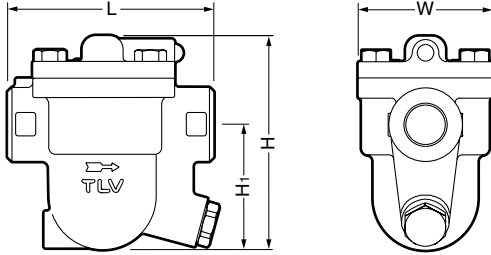

J3S-X Screwed* (in)

Size	L	H	H ₁	W	Weight (lb)
1/2	4 3/4	4 11/16	3	3 1/8	5.5
3/4			2 7/8		5.7
1		5	3		6.2

* NPT, other standards available

● **J3S-X** Flanged

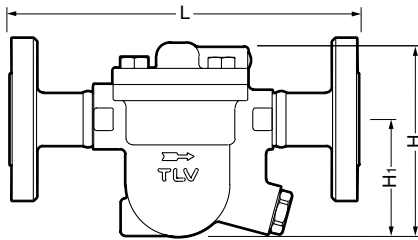

J3S-X Flanged (in)

Size	L		H	H ₁	Weight* (lb)
	Connects to ASME Class				
	150RF	300RF			
1/2	7 11/16	7 11/16	4 11/16	3	8.4
3/4	8 7/16	8 7/16			11
1	9 1/4	9 1/4			12

Other standards available, but length and weight may vary
* Weight is for Class 300 RF

Discharge Capacity

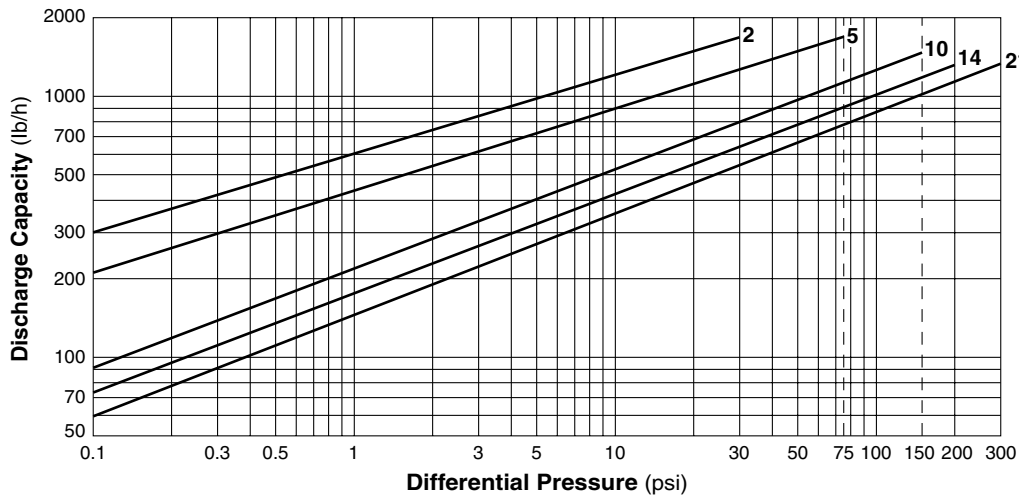

1. Line numbers within the graph are orifice numbers.
2. Differential pressure is the difference between the inlet and outlet pressure of the trap.
3. Capacities are based on continuous discharge of condensate 11°F below saturated steam temperature.
4. Recommended safety factor: at least 1.5.

CAUTION Do not use traps under conditions that exceed maximum differential pressure, as condensate backup will occur!

TLV CORPORATION

13901 South Lakes Drive, Charlotte, NC 28273-6790
 Phone: 704-597-9070 Fax: 704-583-1610
 E-mail: tlv@tlvengineering.com
 For Technical Service 1-800 "TLV TRAP"



Manufacturer

TLV CO., LTD.
 Kakogawa, Japan
 is approved by LRQA Ltd. to ISO 9001/14001

ISO 9001/ISO 14001

