



DIRECT-ACTING PRESSURE REDUCING VALVE FOR STEAM AND AIR

MODEL DR20 STAINLESS STEEL

COMPACT STAINLESS STEEL DIRECT-ACTING PRV FOR STEAM AND AIR

Features

Extremely compact pressure reducing valve for use on small process equipment.

1. Exceptionally light and compact PRV.
2. Wetted parts are of all stainless steel construction with high durability and corrosion resistance for long service life.
3. Stable secondary pressure.
4. High flow rate for its class.
5. Capable of a 30:1 pressure reduction.
6. Easy to operate and adjust.
7. Built-in screen ensures extended trouble-free operation.
8. Easy, in-line access to internal parts simplifies cleaning and reduces maintenance cost.

For installation in horizontal piping (with adjustment handle facing up).



Specifications

Model	DR20-2	DR20-6	DR20-10
Connection	Screwed, Flanged		
Size	1/2", 3/4", 1" / DN 15, 20, 25		
Maximum Operating Pressure (barg) PMO	16		
Maximum Operating Temperature (°C) TMO	220		
Primary Pressure Range (barg)	2 – 16		6 – 16
Adjustable Pressure Range (barg)	0.14 – 2, but not less than 1/30 of primary pressure	1.8 – 6	5.4 – 10
Applicable Fluids*	Secondary pressure must not exceed 90% of primary pressure Steam, Air		

* Do not use for toxic, flammable, or otherwise hazardous fluids.

1 bar = 0.1 MPa

PRESSURE SHELL DESIGN CONDITIONS (NOT OPERATING CONDITIONS): Maximum Allowable Pressure (barg) PMA: 20
Maximum Allowable Temperature (°C) TMA: 220



To avoid abnormal operation, accidents or serious injury, DO NOT use this product outside of the specification range.
Local regulations may restrict the use of this product to below the conditions quoted.

No.	Description	Material	DIN*	ASTM/AISI*
①	Body	Cast Stainless Steel A351 Gr.CF8	1.4312	—
②	Cover	Cast Stainless Steel A351 Gr.CF8	1.4312	—
③ ^V	Screen	Stainless Steel SUS430	1.4016	AISI430
④ ^V	Coil Spring	Stainless Steel SUS304	1.4301	AISI304
⑤ ^V	Main Valve	Stainless Steel SUS420F	1.4028	AISI420F
⑥ ^{MV}	Valve Seat Gasket	Fluorine Resin PTFE	PTFE	PTFE
⑦ ^V	Valve Seat	Stainless Steel SUS420F	1.4028	AISI420F
⑧ ^S	Spacer	Cast Stainless Steel A351 Gr.CF8	1.4312	—
⑨	Snap Ring	Stainless Steel SUS304	1.4301	AISI304
⑩ ^S	Valve Stem	Stainless Steel SUS303	1.4305	AISI303
⑪ ^B	Bellows	Stainless Steel SUS321	1.4541	AISI321
⑫ ^{MSVB}	Cover Gasket	Fluorine Resin PTFE	PTFE	PTFE
⑬	Coil Spring	Stainless Steel SUS303	1.4301	AISI304
⑭	Spring Guide	Carbon Tool Steel SPCC	1.0330	A109
⑮	Steel Ball	High-Cr Bearing Steel SUJ2	1.2067	A485
⑯	Cover Bolt	Stainless Steel SUS304	1.4301	AISI304
⑰	Locknut	Stainless Steel SUS304	1.4301	AISI304
⑱	Adjustment Handle	Nylon/Stainless Steel SUS304	-/1.4301	-/AISI304
⑲	Nameplate	Stainless Steel SUS304	1.4301	AISI304
⑳	Retaining Ring	Stainless Steel SUS304	1.4301	AISI304
㉑	Retainer	Carbon Tool Steel SPCC	1.0330	A109
㉒ ^S	Slide Bearing**	Polymer Resin	—	—
㉓ ^S	Snap Ring**	Stainless Steel SUS316	1.4401	AISI316
㉔	Flange***	Cast Stainless Steel A351 Gr.CF8	1.4312	—

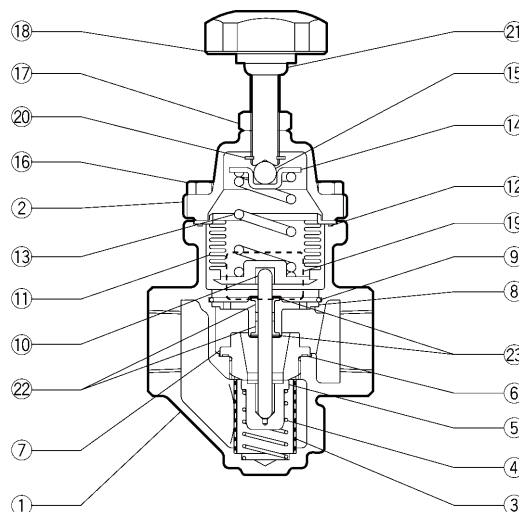

* Equivalent material ** Incorporated with the spacer and must be replaced as a set with the spacer.

Replacement kits available: (M) maintenance parts, (S) repair parts for spacer, (V) repair parts for main valve, (B) repair parts for bellows

*** Shown on reverse

Dimensions

● **DR20**
Screwed

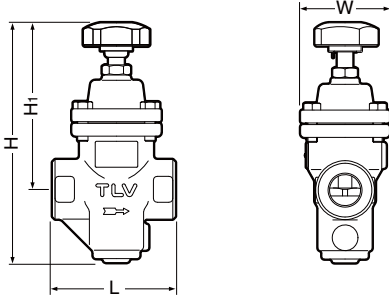

DR20 Screwed* (mm)

Size	L	W	H	H ₁	Weight (kg)
1/2"	95	69	185	130	1.9
3/4"					1.8
1"					

* BSP DIN 2999, other standards available

● **DR20**
Flanged

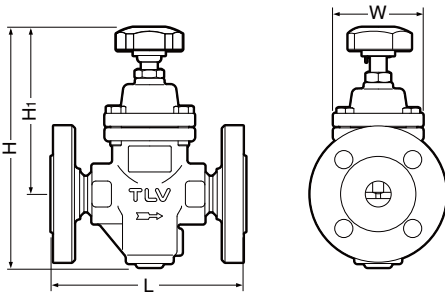

DR20 Flanged (mm)

DN	L			W	H	H ₁	Weight* (kg)
	DIN 2501	ASME Class					
	PN25/40	150RF	300RF				
15	150	150	150	69	185	130	3.3
20							3.8
25							4.2

Other standards available, but length and weight may vary

* Weight is for DIN PN 25/40

Sizing Chart and Flow Graph (Max. Flow Rate)

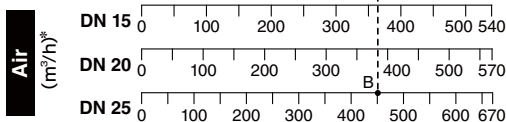
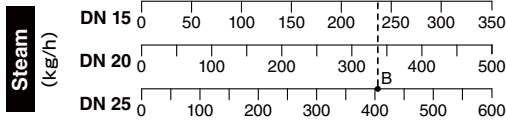
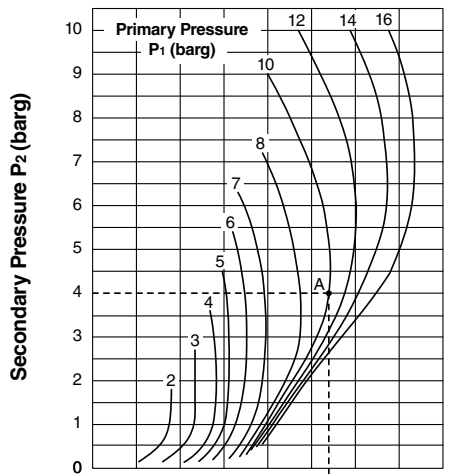

* Equivalent flow of air at 20°C under atmospheric pressure

Sizing Example

For a primary pressure of 10 barg, a set pressure of 4 barg, and a maximum saturated steam flow rate of 400 kg/h, or air flow rate of 400 m³/h, select an appropriate size.

Locate point A, where the primary pressure (P₁ = 10 barg) intersects the set pressure (P₂ = 4 barg). Move straight down from point A until reaching a size with a rated flow rate exceeding the desired flow rate. This first occurs at point B on the DN 25 flow rate line.

- The DN 25 size should be selected.
- For a set pressure of 4 barg, model DR20-6 should be selected (see the adjustable pressure range information given in the specifications (overleaf)).

Cv & Kvs Values

Size (DN)	15	20	25
Kvs (DIN)	1.7	2.6	3.1
Cv (UK)	1.7	2.5	3.0
Cv (US)	2.0	3.0	3.6

Cv & Kvs values are for maximum flow

Manufacturer

ISO 9001/ISO 14001

TLV CO., LTD.
Kakogawa, Japan

is approved by LRQA Ltd. to ISO 9001/14001

