



FREE FLOAT® AIR TRAP

MODEL JA3 DUCTILE CAST IRON

FREE FLOAT DRAIN TRAP WITH TIGHT SHUT-OFF FOR AIR SERVICE

Features

Light free float air trap for pipe-end installation to automatically drain condensate and oil from compressed air systems.

1. Self-modulating free float provides soft, continuous, and smooth, low velocity discharge as process loads vary.
2. Perfect air-tight seal, even under low-load conditions.
3. Only one moving part, the free float, prevents concentrated wear and provides long maintenance-free service life.
4. Built-in screen with large surface area ensures trouble free service.
5. Manual blow down device allows cleaning of the valve seat from outside during operation.
6. Major internal parts made of stainless steel.



Specifications

Model	JA3	
Connection	Screwed	
Size	1/2", 3/4", 1"	
Maximum Operating Pressure (barg) PMO	16	
Maximum Differential Pressure (bar) ΔPMO	16	
Maximum Operating Temperature (°C) TMO	100	
Applicable Fluid*	Air	

* Do not use for toxic, flammable or otherwise hazardous fluids.

1 bar = 0.1 MPa

PRESSURE SHELL DESIGN CONDITIONS (NOT OPERATING CONDITIONS): Maximum Allowable Pressure (barg) PMA: 21
Maximum Allowable Temperature (°C) TMA: 100



To avoid abnormal operation, accidents or serious injury, DO NOT use this product outside of the specification range. Local regulations may restrict the use of this product to below the conditions quoted.

No.	Description	Material	DIN*	ASTM/AISI*
①	Body	Ductile Cast Iron GGG40.3	0.7043	A395
②	Cover	Ductile Cast Iron FCD450	0.7040	A536
③ ^F	Float	Stainless Steel SUS316L	1.4404	AISI316L
④ ^{MR}	Holder Nut Gasket	Fluorine Resin PTFE	PTFE	PTFE
⑤ ^{MR}	Valve Seat Holder O-Ring	Nitrile Rubber NBR	NBR	D2000BF
⑥ ^R	Valve Seat	Nitrile Rubber NBR	NBR	D2000BF
⑦	Nameplate	Stainless Steel SUS304	1.4301	AISI304
⑧ ^R	Valve Seat Holder Nut	Stainless Steel SUS420F	1.4028	AISI420F
⑨	Balancing Line Plug	Carbon Steel SS400	1.0037	A6
⑩	Alignment Pin	Bearing Steel SUJ2	1.2067	A485
⑪ ^{MR}	Cover Gasket	Fluorine Resin PTFE	PTFE	PTFE
⑫ ^R	Screen	Stainless Steel SUS430	1.4016	AISI430
⑬	Cover Bolt	Carbon Steel S45C	1.0503	AISI1045
⑭ ^R	Cleaning Needle	Stainless Steel SUS420F	1.4028	AISI420F
⑮ ^{MR}	Needle O-Ring	Nitrile Rubber NBR	NBR	D2000BF
⑯ ^R	Coil Spring	Stainless Steel SUS304	1.4301	AISI304
⑰ ^R	Split Pin	Stainless Steel SUS304	1.4301	AISI304
⑱ ^R	Plunger	Stainless Steel SUS420F	1.4028	AISI420F
⑲ ^R	Guard Bushing	Carbon Steel SGP	1.0035	A53 Type F
⑳ ^R	Valve Seat Holder	Stainless Steel SUS420F	1.4028	AISI420F
㉑ ^R	Snap Ring	Stainless Steel SUS304	1.4301	AISI304
㉒ ^R	Washer	Stainless Steel SUS304	1.4301	AISI304
㉓	Drain Plug Gasket**	Soft Iron SUYP	1.1121	AISI1010
㉔	Drain Plug**	Carbon Steel S25C	1.1158	AISI1025

* Equivalent materials * Option

Replacement kits available: (M) maintenance parts, (R) repair parts, (F) float

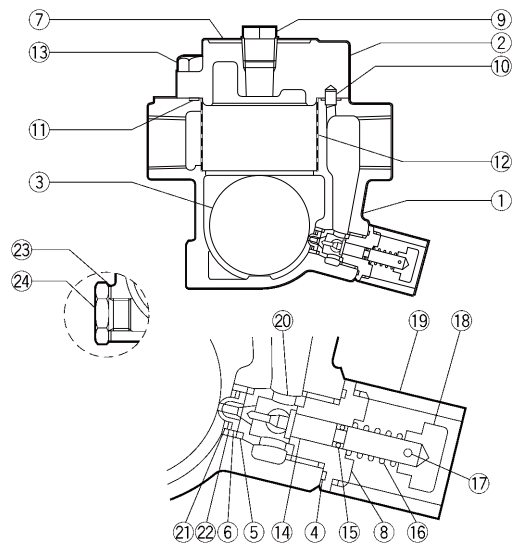

Copyright © TLV

Dimensions

● **JA3** Screwed

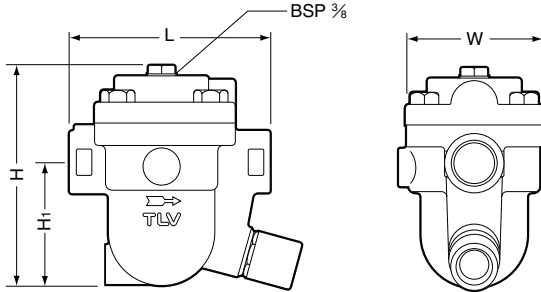

JA3 Screwed* (mm)

Size	L	H	H ₁	W	Weight (kg)
1/2"	120	130	75	80	2.7
3/4"			73		2.8
1"		137	75		3.0

* BSP DIN 2999, other standards available

NOTE

A pressure-balancing line must be connected to the air system from the balancing port at the top of the trap to a place above any possible condensate accumulation in the system.

Discharge Capacity

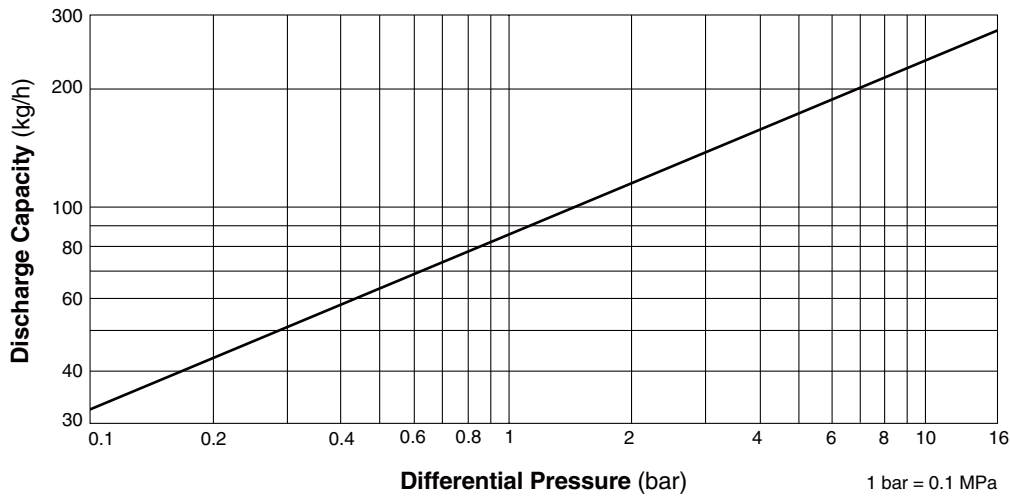

1. Differential pressure is the difference between the inlet and outlet pressure of the trap.
2. The chart is applicable to condensate below 100 °C.
3. The discharge capacity is for a liquid with specific gravity of 1.
4. Recommended safety factor: at least 1.5.



DO NOT use traps under conditions that exceed maximum differential pressure, as condensate backup will occur!

Manufacturer

ISO 9001/ISO 14001

TLV CO., LTD.
Kakogawa, Japan

is approved by LRQA Ltd. to ISO 9001/14001

