



TRAP STATION

MODEL V1/V2

FORGED TRAP STATION EQUIPPED WITH BUILT-IN BELLOWS SEALED VALVE

Features

Compact valve and steam trap station for use with condensate manifolds or applications with limited installation space.

1. All wetted components are stainless steel.
2. Rugged, compact and versatile design minimizes installation area and easily adapts to plant requirements.
3. Built-in bellows-sealed valves have durable stainless steel bellows to eliminate gland leakage.
4. Good seal with stellite hardened surfaces on valve plug and valve seat.
5. **QuickTrap** 2-bolt universal connection permits trap unit replacement in minutes without disturbing piping.
6. Built-in screen with large surface area ensures trouble-free operation.
7. Includes built-in BD2 blowdown valves for station blowdown and trap testing.

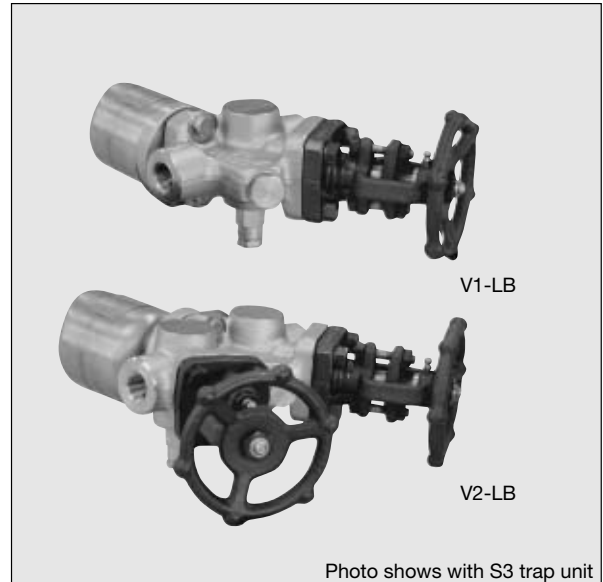

Photo shows with S3 trap unit

Specifications

Model	V1-RB, V1-LB		V2-RB, V2-LB	
	Connection	Screwed	Socket Welded	Screwed
Size	1/2", 3/4"		1/2", 3/4"	
Built-in Valve Location	1 valve at trap inlet		1 valve at trap inlet, 1 valve at trap outlet	
Maximum Operating Pressure (barg) PMO	46*			
Maximum Operating Temperature (°C) TMO	400*			

PRESSURE SHELL DESIGN CONDITIONS (**NOT** OPERATING CONDITIONS): Maximum Allowable Pressure (barg) PMA: 46* 1 bar = 0.1 MPa

* For trap station only; further restricted by mounted trap unit.

Maximum Allowable Temperature (°C) TMA: 400*



To avoid abnormal operation, accidents or serious injury, DO NOT use this product outside of the specification range. Local regulations may restrict the use of this product to below the conditions quoted.

No.	Description	Material	DIN*	ASTM/AISI*
①	Body	Stainless Steel SUS304	1.4301	AISI304
② ^R	Valve Bonnet	Carbon Steel A105	1.0460	—
③ ^R	Valve Plug	Stainless Steel A276-304 + Stellite	—	—
④	Valve Seat	Stainless Steel A276-410 + Stellite	—	—
⑤ ^R	Valve Stem	Stainless Steel A276-410	—	—
⑥ ^R	Bellows	Stainless Steel SUS316L	1.4404	AISI316L
⑦ ^R	Bellows Flange	Stainless Steel A276-316L	1.4404	—
⑧ ^R	Lower Bonnet Gasket	Graphite/Stainless Steel SUS316	- /1.4401	- /AISI316
⑨ ^R	Upper Bonnet Gasket	Graphite/Stainless Steel SUS304	- /1.4301	- /AISI304
⑩ ^R	Bonnet Bolt	Alloy Steel A193 Gr.B7	1.7225	—
⑪ ^R	Gland Packing	Graphite	—	—
⑫ ^R	Gland Bushing	Stainless Steel A276-410	—	—
⑬ ^R	Gland Flange	Carbon Steel A105	1.0460	—
⑭ ^R	Gland Eye Bolt	Alloy Steel A193 Gr.B7	1.7225	—
⑮ ^R	Gland Nut	Carbon Steel A194 Gr.2H	—	—
⑯ ^R	Handwheel	Ductile Cast Iron FCD450	0.7040	A536
⑰ ^R	Handwheel Nut	Carbon Steel S25C	1.1158	AISI1025
⑱	Nameplate	Stainless Steel SUS304	1.4301	AISI304
⑲ ^R	Screen	Stainless Steel SUS430	1.4106	AISI430
⑳ ^{MR}	Screen Holder Gasket	Stainless Steel SUS316L	1.4404	AISI316L
㉑	Screen Holder Plug	Stainless Steel SUS303	1.4305	AISI303
㉒	Blowdown Valve BD2	Stainless Steel A351 Gr.CF8	1.4312	—
㉓ ^{MR}	BD2 Gasket	Stainless Steel SUS316L	1.4404	AISI316L

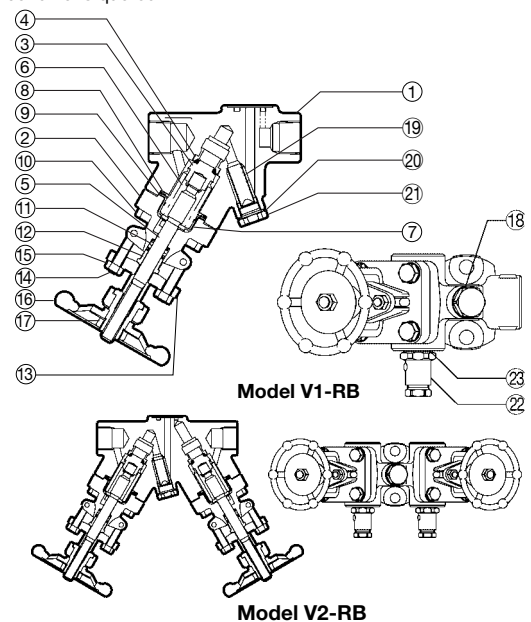

* Equivalent materials

Replacement kits available: (M) maintenance parts, (R) repair parts
Kits include parts for only one valve unit; V2 may require two kits.

Dimensions

● **V1-RB • V1-LB** Screwed & Socket Welded

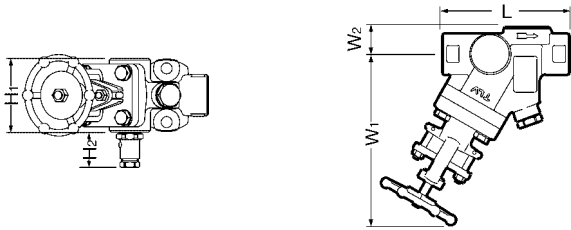

V1-RB shown; V1-LB is inverted (opposite flow direction)

● **V2-RB • V2-LB** Screwed & Socket Welded

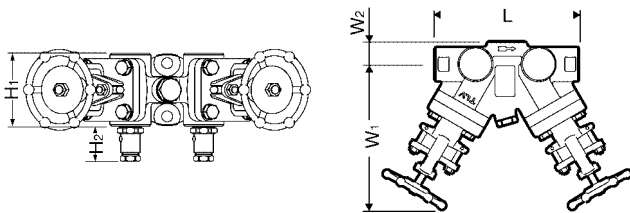

V2-RB shown; V2-LB is inverted (opposite flow direction)

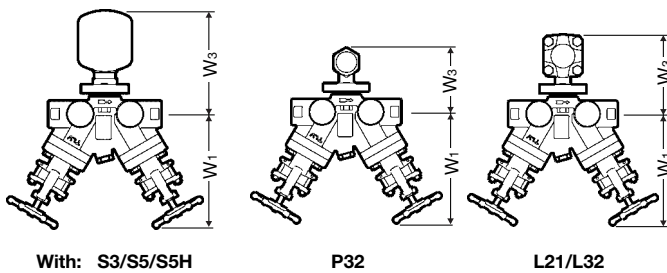

With: S3/S5/S5H

P32

L21/L32

V1-RB • V1-LB (mm)

Size	DN	L	H ₁	H ₂	W ₁ *	W ₂	Weight (kg)
1/2"	15	120	70	33	180	26	3.4
3/4"	20						

Screwed connections are NPT; socket welded connections are ASME B16.11 (see below); other standards available
* At full-open position

V2-RB • V2-LB (mm)

Size	DN	L	H ₁	H ₂	W ₁ *	W ₂	Weight (kg)
1/2"	15	160	70	33	180	26	5.8
3/4"	20						

Screwed connections are NPT; socket welded connections are ASME B16.11-2005 (see below); other standards available
* At full-open position

● **Socket Weld Connections** (mm)

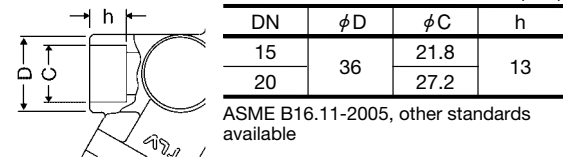

DN	φ D	φ C	h
15	36	21.8	13
20		27.2	

ASME B16.11-2005, other standards available

Model	W ₁ (mm)	W ₃ (mm)	Weight (kg)	
			With V1*	With V2*
S3	180	143	4.3	6.7
S5		175	4.7	7.1
S5H		178	4.1	6.5
P32		89	4.4	6.8
L21/L32		110	4.4	6.8

* Combined weight of trap station with mounted trap unit

Valve Series

Model	V1-RB	V1-LB	V2-RB	V2-LB
Station Picture				
Flow Diagram				
Flow Direction	Right	Left	Right	Left
Inlet Valve	✓	✓	✓	✓
Outlet Valve	—	—	✓	✓
Trap Inlet Blowdown Valve	✓	✓	✓	✓
Trap Outlet Blowdown Valve	—	—	✓	✓
Available Trap Units*	Free Float	S3 / S5 / S5H		
	Thermodynamic	P32		
	Thermostatic	L21 / L32		

* For more information, see the **QuickTrap** specifications data sheet for the steam trap employing the desired trap unit (trap unit - **QuickTrap** data sheet): S3 - FS3; S5 - FS5; S5H - FS5; P32 - FP32; L21 - FL21/FL32; L32 - FL21/FL32

** Capacities shown here will vary depending on orifice numbers, type of X-element and/or pressure differential.

● **Steam Trap Unit Specifications***

Free Float Steam Trap S3 / S5 / S5H	
PMO: 21 / 32 / 46 barg	
TMO: 400 / 400 / 425 °C	
Max. Discharge Capacity** 215 / 670 / 245 kg/h	
Thermodynamic Steam Trap P32	
PMO: 32 barg	
TMO: 350 °C	
Max. Discharge Capacity** 540 kg/h	
Thermostatic Steam Trap L21 / L32	
PMO: 21 / 32 barg	
TMO: 235 / 240 °C	
Max. Discharge Capacity** 760 / 530 kg/h	

Manufacturer

TLV® CO., LTD.
Kakogawa, Japan

is approved by LRQA Ltd. to ISO 9001/14001

ISO 9001/ISO 14001

