



Manufacturer
TLV. CO., LTD.

Kakogawa, Japan
is approved by LRQA LTD. to ISO 9001/14001



Instruction Manual

Free Float Air Trap
JA3·JAF3 / JA5·JAF5
JA7 / JA7.2 / JA7.5 / JA8

Copyright © 2015 by TLV CO., LTD.

All rights reserved

Contents

Safety Considerations	2
Checking the Piping	4
Operation	5
Specifications	6
Configuration	7
Installation	10
The Need for a Pressure-balancing Line	11
Maintenance.....	12
Disassembly / Reassembly	13
Troubleshooting	18
Product Warranty	19

Introduction

Thank you for purchasing the **TLV** free float air trap.

This product has been thoroughly inspected before being shipped from the factory. When the product is delivered, before doing anything else, check the specifications and external appearance to make sure nothing is out of the ordinary. Also be sure to read this manual carefully before use and follow the instructions to be sure of using the product properly.







If detailed instructions for special order specifications or options not contained in this manual are required, please contact **TLV** for full details.

This instruction manual is intended for use with the model(s) listed on the front cover. It is necessary not only for installation, but for subsequent maintenance, disassembly/reassembly and troubleshooting. Please keep it in a safe place for future reference.

Safety Considerations

- Read this section carefully before use and be sure to follow the instructions.
- Installation, inspection, maintenance, repairs, disassembly, adjustment and valve opening/closing should be carried out only by trained maintenance personnel.
- The precautions listed in this manual are designed to ensure safety and prevent equipment damage and personal injury. For situations that may occur as a result of erroneous handling, three different types of cautionary items are used to indicate the degree of urgency and the scale of potential damage and danger: DANGER, WARNING and CAUTION.
- The three types of cautionary items above are very important for safety: be sure to observe all of them as they relate to installation, use, maintenance and repair. Furthermore, TLV accepts no responsibility for any accidents or damage occurring as a result of failure to observe these precautions.

Symbols

	Indicates a DANGER, WARNING or CAUTION item.
	Indicates an urgent situation which poses a threat of death or serious injury
	Indicates that there is a potential threat of death or serious injury
	Indicates that there is a possibility of injury or equipment / product damage
	NEVER apply direct heat to the float. The float may explode due to increased internal pressure, causing accidents leading to serious injury or damage to property and equipment.
	Install properly and DO NOT use this product outside the recommended operating pressure, temperature and other specification ranges. Improper use may result in such hazards as damage to the product or malfunctions that may lead to serious accidents. Local regulations may restrict the use of this product to below the conditions quoted.
	DO NOT use this product in excess of the maximum operating pressure differential. Such use could make discharge impossible (blocked).
	Use hoisting equipment for heavy objects (weighing approximately 20 kg (44 lb) or more). Failure to do so may result in back strain or other injury if the object should fall.
	Take measures to prevent people from coming into direct contact with product outlets. Failure to do so may result in burns or other injury from the discharge of fluids.

Safety considerations continued on next page.

 CAUTION	<p>When disassembling or removing the product, wait until the internal pressure equals atmospheric pressure and the surface of the product has cooled to room temperature.</p> <p>Disassembling or removing the product when it is hot or under pressure may lead to discharge of fluids, causing burns, other injuries or damage.</p>
	<p>Be sure to use only the recommended components when repairing the product, and NEVER attempt to modify the product in any way.</p> <p>Failure to observe these precautions may result in damage to the product and burns or other injury due to malfunction or the discharge of fluids.</p>
	<p>Do not use excessive force when connecting threaded pipes to the product.</p> <p>Over-tightening may cause breakage leading to fluid discharge, which may cause burns or other injury.</p>
	<p>Use only under conditions in which no freeze-up will occur.</p> <p>Freezing may damage the product, leading to fluid discharge, which may cause burns or other injury.</p>
	<p>Use only under conditions in which no water hammer will occur.</p> <p>The impact of water hammer may damage the product, leading to fluid discharge, which may cause burns or other injury.</p>

Checking the Piping



Use only under conditions in which no water hammer will occur. The impact of water hammer may damage the product, leading to fluid discharge, which may cause burns or other injury.

Check to make sure that the pipes to be connected to the trap have been installed properly.

1. Is the pipe diameter suitable?
2. Is the piping where the trap is to be installed horizontal?
3. Has sufficient space been secured for maintenance?
4. Have isolation valves been installed at the inlet and outlet? If the outlet is subject to back pressure, has a check valve (TLV-CK) been installed?
5. Is the inlet pipe as short as possible, with as few bends as possible, and installed so the liquid will flow naturally down into the trap?
6. Has the piping work been done correctly, as shown in the figures below?

NOTE: Selected examples are from piping for main lines.

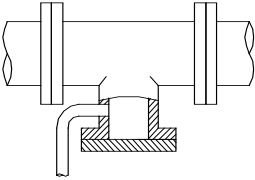
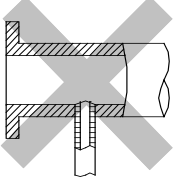
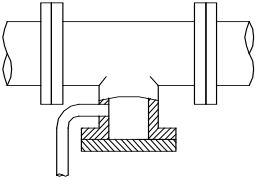
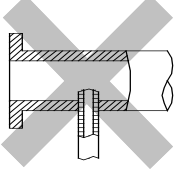
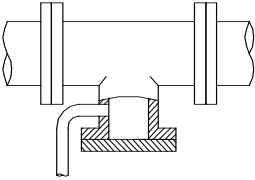
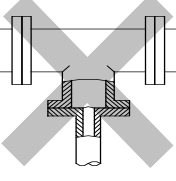
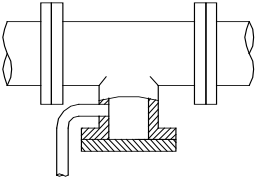
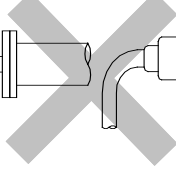
Requirement	Correct	Incorrect
Install catchpot with the proper diameter.		 Diameter is too small.
Make sure the flow of condensate is not obstructed.		 Diameter is too small and inlet protrudes into pipe interior.
To prevent rust and scale from flowing into the trap, the inlet pipe should be connected 25 – 50 mm (1 – 2 in) above the base of the T-pipe.		 Rust and scale flow into the trap with the condensate.
When installing on the blind end, make sure the flow of condensate is not obstructed.		 Condensate collects in the pipe.

Operation

Principles of condensate discharge:

1. Startup

At startup, a small amount of condensate will have accumulated in the body. The float and the valve seat will form a water-seal.

Note: When there is no condensate in the body, it will be necessary to prime the trap with a small amount of water through the pressure-balancing port or line to ensure a seal (after initial installation and after disassembly or maintenance)

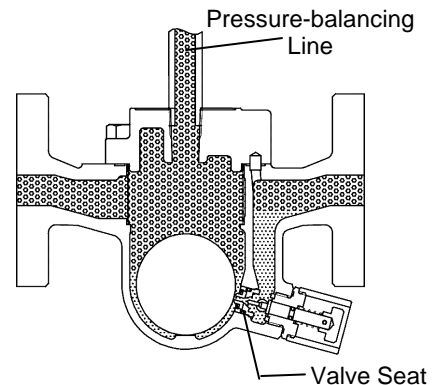

2. Condensate Discharge

As air is supplied, condensate flow begins. The rising condensate level causes the float to rise due to buoyancy, opening the valve seat and allowing condensate to be discharged.

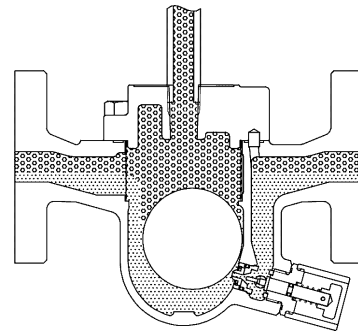

3. Discharge of Large Quantities of Condensate

Increases in the condensate inflow rate cause the condensate level in the trap to rise. The float consequently rises and enlarges the opening of the valve seat, allowing more condensate to be discharged. In this manner, continuous condensate discharge occurs while the opening size of the valve seat varies depending on the condensate flow rate.

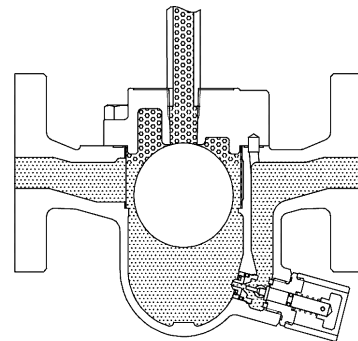

4. Closed Position

When the condensate flow rate decreases, the float falls, closing off the valve seat opening. A water seal is maintained at all times over the valve seat to prevent air loss.

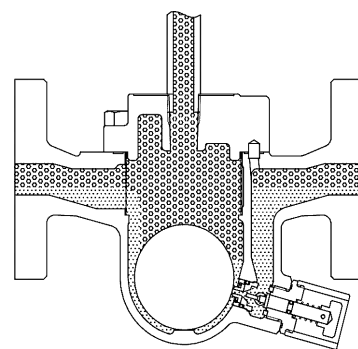

Air



Condensate

Specifications



Install properly and **DO NOT** use this product outside the recommended operating pressure, temperature and other specification ranges. Improper use may result in such hazards as damage to the product or malfunctions which may lead to serious accidents. Local regulations may restrict the use of this product to below the conditions quoted.



DO NOT use this product in excess of the maximum operating pressure differential; such use could make discharge impossible (blocked).



Use only under conditions in which no freeze-up will occur. Freezing may damage the product, leading to fluid discharge, which may cause burns or other injury.

Refer to the product nameplate for detailed specifications.

JA3•JAF3

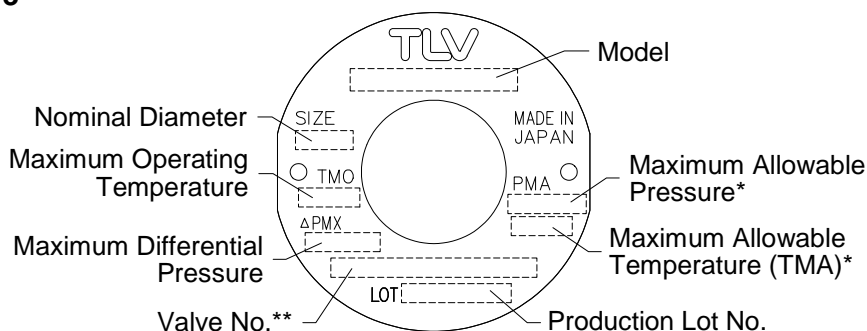

JA5•JAF5 / JA7 / JA7.2 / JA7.5 / JA8

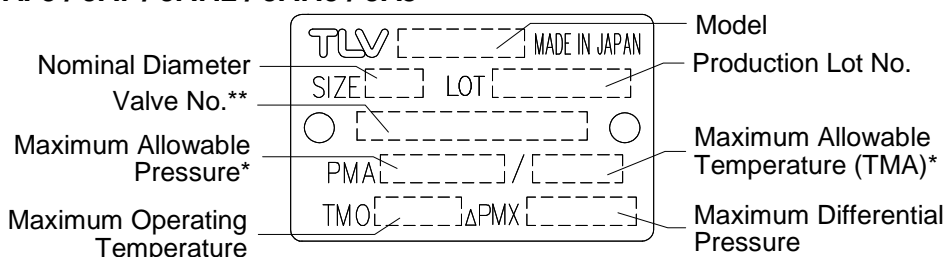

* Maximum allowable pressure (PMA) and maximum allowable temperature (TMA) are PRESSURE SHELL DESIGN CONDITIONS, **NOT** OPERATING CONDITIONS.

** Valve No. is displayed for products with options. This item is omitted from the nameplate when there are no options.

Minimum Required Condensate Load

Tight sealing can be secured by maintaining the Minimum Required Condensate Load, as air leaks may result if the inflowing condensate load falls below it.

Model		JA7.2	JA7.5	JA8	
				Orifice No.5 or below	Above orifice No.5
Minimum Required Condensate Load	kg/h	10	10	20	15
	lb/h	22	22	44	33

NOTE: Orifice No. is the indication to distinguish the valve seats usable at different operating pressures.

Configuration

JA3•JAF3

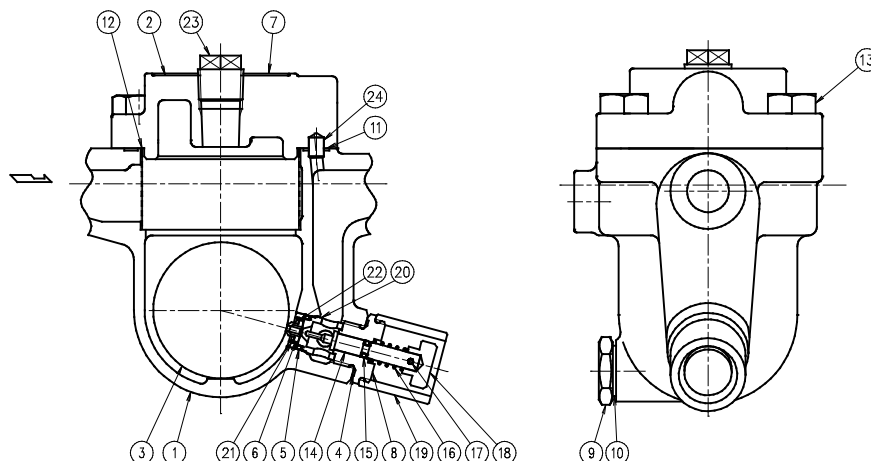

No.	Name	M*	R*	F*	No.	Name	M*	R*	F*
1	Body				13	Cover Bolt			
2	Cover				14	Needle		✓	
3	Float			✓	15	Needle O-Ring	✓	✓	
4	Holder Nut Gasket	✓	✓		16	Coil Spring		✓	
5	Valve Seat Holder O-Ring	✓	✓		17	Split Pin		✓	
6	Valve Seat		✓		18	Plunger		✓	
7	Nameplate				19	Guard Bushing		✓	
8	Valve Seat Holder Nut		✓		20	Valve Seat Holder		✓	
9	Drain Plug**				21	Snap Ring		✓	
10	Drain Plug Gasket**	✓	✓		22	Washer		✓	
11	Cover Gasket	✓	✓		23	Balancing Line Plug			
12	Screen		✓		24	Alignment Pin			

* Replacement parts are available only in the following kits: **M** = Maintenance Kit, **R** = Repair Kit, **F**= Float

** Optional

JA5•JAF5

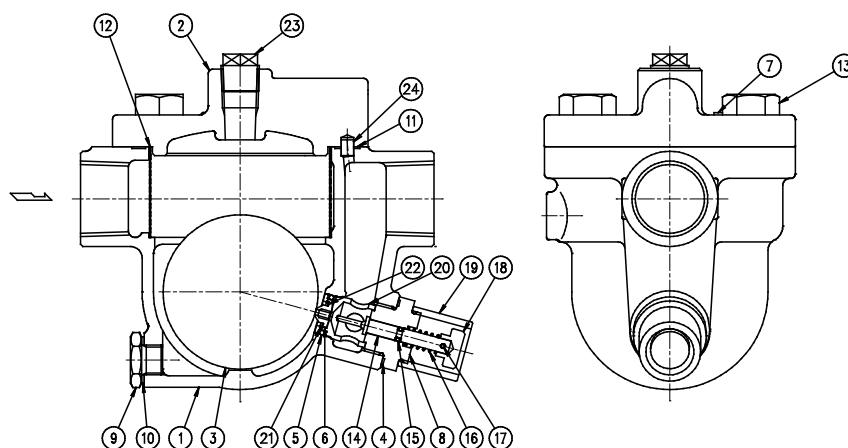

No.	Name	M*	R*	F*	No.	Name	M*	R*	F*
1	Body				13	Cover Bolt			
2	Cover				14	Needle		✓	
3	Float			✓	15	Needle O-Ring	✓	✓	
4	Holder Nut Gasket	✓	✓		16	Coil Spring		✓	
5	Valve Seat Holder O-Ring	✓	✓		17	Split Pin		✓	
6	Valve Seat		✓		18	Plunger		✓	
7	Nameplate				19	Guard Bushing		✓	
8	Valve Seat Holder Nut		✓		20	Valve Seat Holder		✓	
9	Drain Plug**				21	Snap Ring		✓	
10	Drain Plug Gasket**	✓	✓		22	Washer		✓	
11	Cover Gasket	✓	✓		23	Balancing Line Plug			
12	Screen		✓		24	Alignment Pin			

* Replacement parts are available only in the following kits: **M** = Maintenance Kit, **R** = Repair Kit, **F**= Float

** Optional

JA7

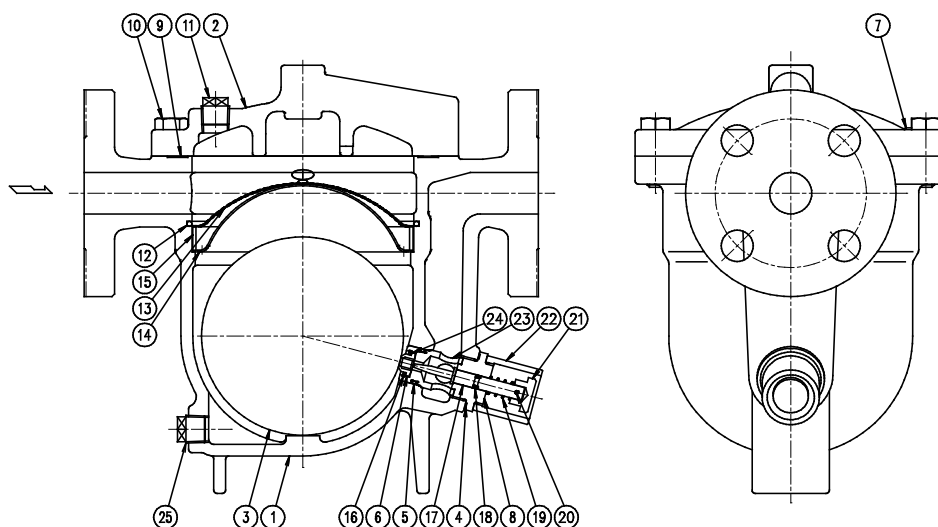

No.	Name	M*	R*	F*	No.	Name	M*	R*	F*
1	Body				14	Screen Holder			
2	Cover				15	Screen Holder Retainer			
3	Float			✓	16	Snap Ring		✓	
4	Holder Nut Gasket	✓	✓		17	Needle		✓	
5	Valve Seat Holder O-Ring	✓	✓		18	Needle O-Ring	✓	✓	
6	Valve Seat		✓		19	Coil Spring		✓	
7	Nameplate				20	Split Pin		✓	
8	Valve Seat Holder Nut		✓		21	Plunger		✓	
9	Cover Gasket	✓	✓		22	Guard Bushing		✓	
10	Cover Bolt				23	Valve Seat Holder		✓	
11	Balancing Line Plug				24	Washer		✓	
12	Snap Ring				25	Drain Plug			
13	Screen		✓						

* Replacement parts are available only in the following kits: **M** = Maintenance Kit, **R** = Repair Kit, **F**= Float

JA7.2

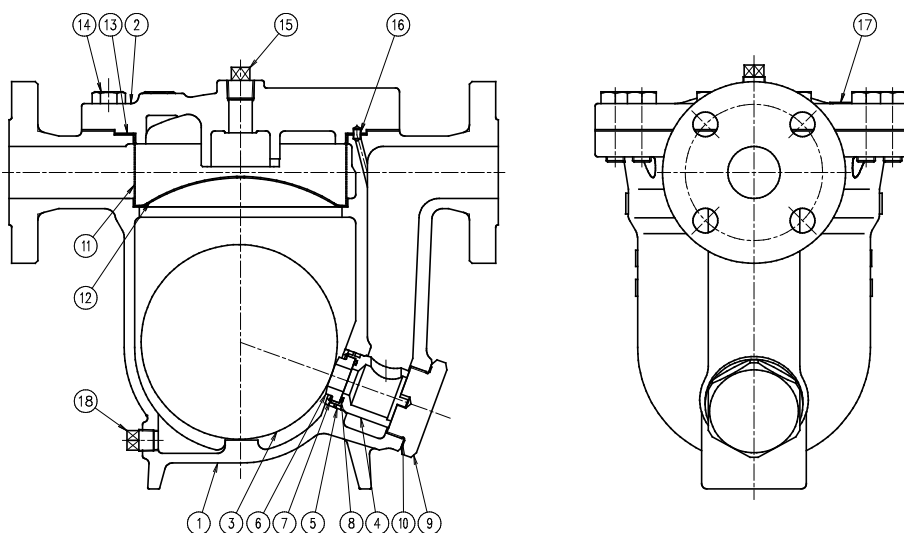

No.	Name	M*	R*	F*	No.	Name	M*	R*	F*
1	Body				10	Holder Plug Gasket	✓	✓	
2	Cover				11	Screen		✓	
3	Float			✓	12	Screen Holder			
4	Valve Seat Holder		✓		13	Cover Gasket	✓	✓	
5	Valve Seat Holder O-Ring	✓	✓		14	Cover Bolt			
6	Valve Seat		✓		15	Balancing Line Plug			
7	Snap Ring		✓		16	Alignment Pin			
8	Valve Seat O-Ring	✓	✓		17	Nameplate			
9	Valve Seat Holder Plug				18	Drain Plug			

* Replacement parts are available only in the following kits: **M** = Maintenance Kit, **R** = Repair Kit, **F**= Float

JA7.5/JA8

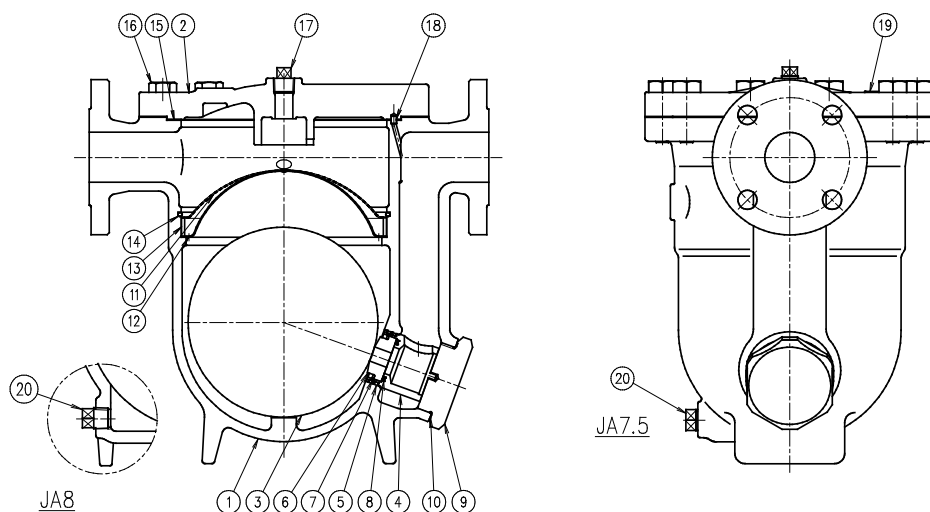

No.	Name	M*	R*	F*	No.	Name	M*	R*	F*
1	Body				11	Screen		✓	
2	Cover				12	Screen Holder			
3	Float			✓	13	Screen Holder Retainer			
4	Valve Seat Holder		✓		14	Snap Ring			
5	Valve Seat Holder O-Ring	✓	✓		15	Cover Gasket	✓	✓	
6	Valve Seat		✓		16	Cover Bolt			
7	Snap Ring		✓		17	Balancing Line Plug			
8	Valve Seat O-Ring	✓	✓		18	Alignment Pin			
9	Valve Seat Holder Plug				19	Nameplate			
10	Holder Plug Gasket	✓	✓		20	Drain Plug			

* Replacement parts are available only in the following kits: **M** = Maintenance Kit, **R** = Repair Kit, **F** = Float

Installation



Install properly and **DO NOT** use this product outside the recommended operating pressure, temperature and other specification ranges. Improper use may result in such hazards as damage to the product or malfunctions which may lead to serious accidents. Local regulations may restrict the use of this product to below the conditions quoted.



Use hoisting equipment for heavy objects (weighing approximately 20 kg (44 lb) or more). Failure to do so may result in back strain or other injury if the object should fall.



Take measures to prevent people from coming into direct contact with product outlets. Failure to do so may result in burns or other injury from the discharge of fluids.



Do not use excessive force when connecting threaded pipes to the product. Over-tightening may cause breakage leading to fluid discharge, which may cause burns or other injury.

Installation, inspection, maintenance, repairs, disassembly, adjustment and valve opening/closing should be carried out only by trained maintenance personnel.

1. Before installation, be sure to remove all protective seals.
2. Before installing the product, blow out the inlet piping to remove any piping scraps, dirt and oil. Close the inlet valve after blowdown.
3. Install the product so that the arrow on the body is pointing in the direction of flow.
4. The trap should be inclined no more than 5° horizontally and front-to-back.
5. Install a condensate outlet valve and outlet piping.
6. To ensure proper condensate flow into the trap, remove the balancing line plug and install a pressure-balancing line. Connect the end of the pressure-balancing line to the air main or an air space above any possible condensate accumulation in the system. For more details, see the section "The Need for a Pressure-balancing Line".
7. To facilitate inspection and maintenance, install a union or a flange where the product has a connection (inlet, pressure-balancing line, condensate outlet). For more details, see the section "The Need for a Pressure-balancing Line".
8. Prime the trap with a small amount of water through the pressure-balancing port or line to ensure a seal. After priming and connecting the pressure-balancing line, open the inlet and outlet valves and check to make sure that the product functions properly.

If there is a problem, determine the cause using the "Troubleshooting" section in this manual.

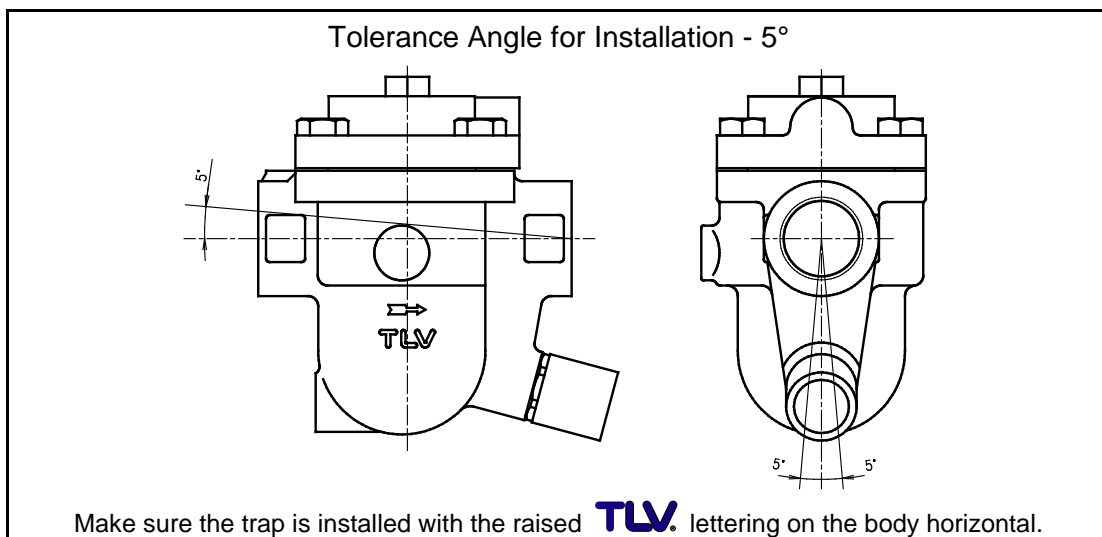

The Need for a Pressure-balancing Line

This air trap is designed to automatically discharge inflowing condensate. However, if the condensate completely fills the inlet path of the trap, air in the trap body will not be able to escape, preventing displacement by condensate, and thus preventing condensate from entering the trap. This phenomena is called air binding. Air binding occurs more often in piping with long horizontal lengths, smaller diameters or multiple bends. To prevent air binding and ensure air can be displaced by incoming condensate, a pressure-balancing line should be installed between the trap cover and the dry portion of the receiver tank or piping.

Connect the pressure-balancing line in the follow manner:

Receiver Tank

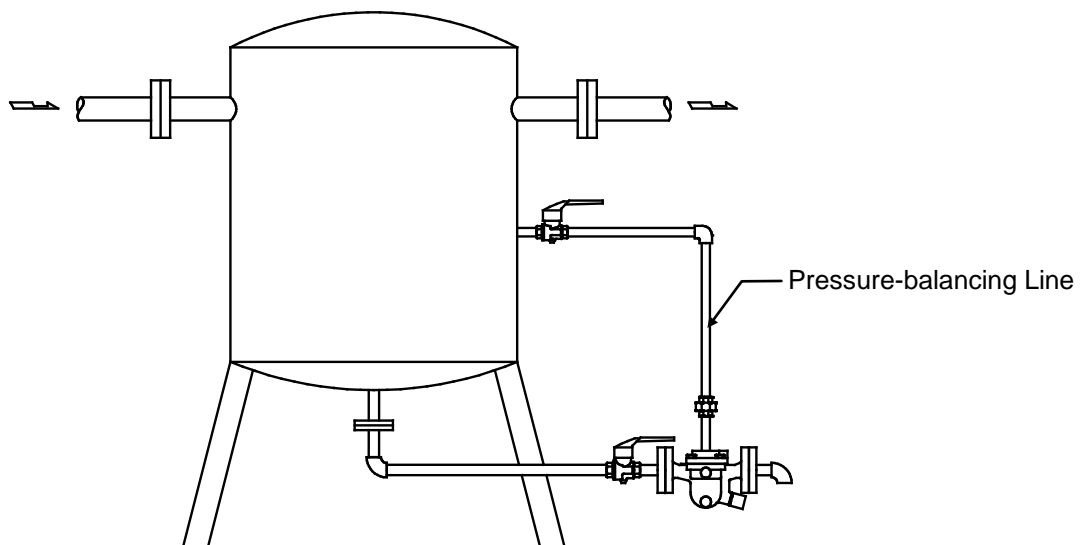

Air Main

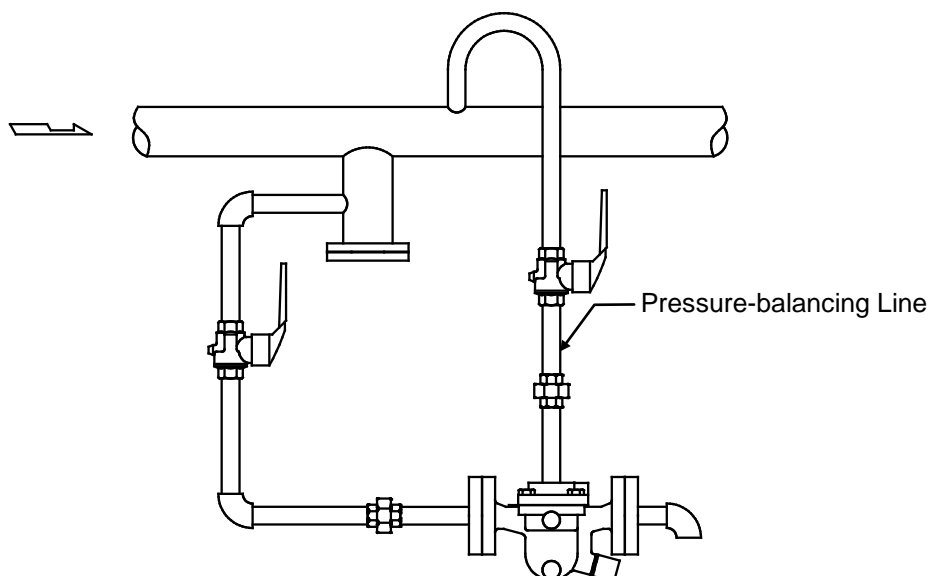

Maintenance



Take measures to prevent people from coming into direct contact with product outlets. Failure to do so may result in burns or other injury from the discharge of fluids.



Be sure to use only the recommended components when repairing the product, and NEVER attempt to modify the product in any way. Failure to observe these precautions may result in damage to the product or burns or other injury due to malfunction or the discharge of fluids.

Operational Inspection

A visual inspection of the following items should be done on a daily basis to determine whether the trap is operating properly or has failed. Periodically (at least biannually) the operation should also be checked by using diagnostic equipment such as a stethoscope or thermometer.

Normal:	Condensate is discharged continuously and the sound of flow can be heard. If there is very little condensate, there is almost no sound of flow.
Blocked: (Discharge Impossible)	No condensate is discharged.
Blowing:	Air continually flows from the outlet and there is a continuous high-pitched sound of flow.
Air Leakage:	Air is discharged through the trap outlet together with condensate, accompanied by a high-pitched sound.

Parts Inspection

When parts have been removed, or during periodic inspections, use the following table to inspect the parts and replace any that are found to be defective.

Procedure	
Gaskets:	check for warping or damage
Screen:	check for clogging or corrosion
Valve Seat:	check for warping or damage
Valve Seat Opening:	check for dirt, oil film, wear or scratches
Float:	check for scratches or dents
Body Interior:	check for build-up

Disassembly / Reassembly



WARNING

NEVER apply direct heat to the float. The float may explode due to increased internal pressure, causing accidents leading to serious injury or damage to property and equipment.



CAUTION

Use hoisting equipment for heavy objects (weighing approximately 20 kg or more). Failure to do so may result in back strain or other injury if the object should fall.



CAUTION

When disassembling or removing the product, wait until the internal pressure equals atmospheric pressure and the surface of the product has cooled to room temperature. Disassembling or removing the product when it is hot or under pressure may lead to discharge of fluids, causing burns, other injuries or damage.

Use the following procedures to remove components. Use the same procedures in reverse to reassemble. (Installation, inspection, maintenance, repairs, disassembly, adjustment and valve opening/closing should be carried only by trained maintenance personnel.)

Drain Plug

Part	JA3 / JAF3 JA5 / JAF5	JA7 / JA7.2 JA7.5 / JA8	During Disassembly	During Reassembly
Drain Plug*	✓	—	Remove with a socket wrench	Consult the table of tightening torques and tighten to the proper torque
Drain Plug Gasket*	✓	—	—	Replace with a new gasket, coat with anti-seize
Drain Plug	—	✓	Remove with a wrench	Wrap threads with sealing tape, consult the table of tightening torques and tighten to the proper torque

*Optional for JA3/JAF3/JA5/JAF5

Detaching / Reattaching Cover

NOTE: Disconnect any lines that must be disconnected before disassembly can take place (inlet piping, pressure-balancing line, condensate discharge piping, etc.).

Part	During Disassembly	During Reassembly
Cover Bolt	Remove with a socket wrench	Consult the table of tightening torques and tighten to the proper torque
Cover	Lift the cover up and off	Make sure the arrow on the cover is pointing in the direction of flow (JA7) Align the cover with the alignment pin (except JA7) and reattach
Alignment Pin	Remove the alignment pin (except JA7)	Insert into the hole its in the body
Cover Gasket	Remove the gasket	Replace with a new gasket if damaged
Balancing Line Plug (When connecting the line for the first time)	Remove with a wrench	— (Connect the pressure-balancing line) When the pressure-balancing line is not necessary, wrap threads with sealing tape, consult the table of tightening torques and tighten to the proper torque

Detaching / Reassembling Components Inside the Body (JA3·JAF3/JA5·JAF5)

Part	During Disassembly	During Reassembly
Screen	Remove by lifting straight up and out while turning	Turn gently while inserting, make sure the top of the screen does not stick up out of the body
Float	Remove, being careful not to scratch the polished surface	Insert, being careful not to scratch the polished surface
Guard Bushing	Turn by finger to remove from the valve seat holder nut	Turn by finger to tighten loosely

Continued on the following page

Part	During Disassembly	During Reassembly
Valve Seat Holder Nut	Remove with a socket wrench	Consult the table of tightening torques and tighten to the proper torque
Holder Nut Gasket	—	Replace with a new gasket if damaged
Valve Seat Holder	Push out from inside the body toward the valve seat holder nut	Pushing it in until it contacts the stopper inside
Valve Seat Holder O-Ring	Be careful not to damage the O-ring as it is made of rubber	Coat with heat resistant grease**; replace with a new valve seat holder O-ring if warped or damaged; fit securely into the groove in the valve seat holder
Snap Ring	Pinch the insides together and remove from the valve seat holder	Insert securely into groove up against the washer be sure that the break in the snap ring lines up with the slot in the groove
Washer	—	—
Valve Seat	Be careful not to damage the rubber valve seat	Replace with a new valve seat if sealing surfaces are warped or damaged
Split Pin*	Be careful not to lose	—
Plunger*	Remove from needle	—
Coil Spring*	—	—
Needle*	Remove without bending	—
Needle O-Ring*	Be careful not to damage the O-ring as it is made of rubber	Coat with heat resistant grease**; replace with a new needle O-ring if warped or damaged; fit securely into the groove in the needle

Detaching / Reassembling Components Inside the Body (JA7)

Part	During Disassembly	During Reassembly
Snap Ring	Pinch the insides together and remove from body	Insert securely into the snap ring groove in the body
Screen	Remove by lifting up and out	Make sure the correct side is facing up
Screen Holder Retainer	Remove by lifting up and out	Place on the screen holder without tilting
Screen Holder	Remove without bending	Place on the ledge inside the body, making sure the rounded side is on top
Float	Remove, being careful not to scratch the polished surface	Insert, being careful not to scratch or misshape
Guard Bushing	Turn by finger to remove from the valve seat holder nut	Turn by finger to tighten loosely
Valve Seat Holder Nut	Remove with a socket wrench	Consult the table of tightening torques and tighten to the proper torque
Holder Nut Gasket	—	Replace with a new gasket if damaged
Valve Seat Holder	Push out from inside the body toward the valve seat holder nut	Push in until it contacts the stopper inside
Valve Seat Holder O-Ring	Be careful not to damage the O-ring as it is made of rubber	Coat with heat resistant grease**; replace with a new O-ring if warped or damaged; fit securely into the groove in the valve seat holder
Snap Ring (for Valve Seat Holder Nut)	Pinch the insides together and remove from the valve seat holder (Fig. A)	Insert securely into groove up against the washer be sure that the break in the snap ring lines up with the slot in the groove
Washer	—	—
Valve Seat	Be careful not to damage the rubber valve seat	Replace with a new valve seat if sealing surfaces are warped or damaged
Split Pin*	Be careful not to lose	—
Plunger*	Remove from needle	—
Coil Spring*	—	—
Needle*	Remove without bending	—
Needle O-Ring*	Be careful not to damage the O-ring as it is made of rubber	Coat with heat resistant grease**; replace with a new O-ring if warped or damaged; fit securely into the groove in the needle

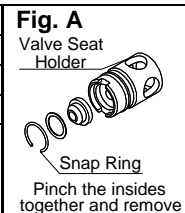

*Detach / Reassemble only when the needle is replaced

**Use silicone grease (for heat resistant grease)

Detaching / Reassembling Components Inside the Body (JA 7.2 / JA7.5 / JA8)

Part	During Disassembly	During Reassembly
Snap Ring (JA7.5 / JA8)	Pinch the insides together and remove from the body	Insert securely into the snap ring groove in the body
Screen	Remove by lifting up and out	Make sure the correct side is facing up (JA7.5 / JA8)
Screen Holder Retainer (JA7.5 / JA8)	Remove by lifting up and out	Place on the screen holder without tilting
Screen Holder	Remove without bending	Place on the ledge inside the body, making sure the rounded side is on top
Float	Remove, being careful not to scratch the polished surface	Insert, being careful not to scratch or misshape
Valve Seat Holder Plug	Remove with a socket wrench	Consult the table of tightening torques and tighten to the proper torque
Holder Plug Gasket	—	Replace with a new gasket if damaged
Valve Seat Holder	Push out from inside the body toward the valve seat holder plug	Insert with the proper orientation; insert from the outside of the body, pushing it in until it contacts the stopper inside; if the condensate discharge hole is pointing sideways, extended use may result in a hole in the body (Fig. B)
Valve Seat Holder O-Ring	Be careful not to damage the O-ring as it is made of rubber	Coat with heat resistant grease*; replace with a new valve seat holder O-ring if warped or damaged; fit securely into groove in the valve seat holder
Snap Ring (for Valve Seat Holder)	Pinch the insides together and remove from the valve seat holder (Fig. C)	Insert securely into groove up against the valve seat, be sure that the break in the snap ring lines up with the slot in the groove
Valve Seat	Be careful not to scratch the sealing surfaces	Replace with a new valve seat if sealing surfaces are warped or damaged. Push replacement valve seat in to insert
Valve Seat O-Ring	Be careful not to damage the O-ring as it is made of rubber	Coat with heat resistant grease*; replace with a new O-ring if warped or damaged; fit securely into groove in the valve seat holder

*Use silicone grease (for heat resistant grease)

Fig. B

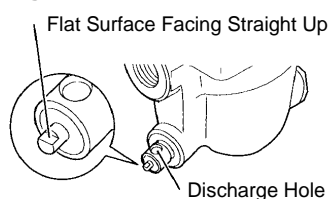

Fig. C

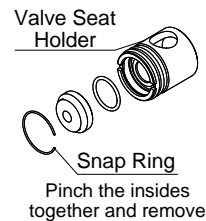

Table of Tightening Torques

Model	Valve Seat Holder Nut or Valve Seat Holder Plug		Drain Plug		Cover Bolt		Balancing Line Plug	
	Torque	Dist. Across Flats	Torque	Dist. Across Flats	Torque	Dist. Across Flats	Torque	Dist. Across Flats
	N·m (lbf·ft)	mm (in)	N·m (lbf·ft)	mm (in)	N·m (lbf·ft)	mm (in)	N·m (lbf·ft)	mm (in)
JA3-JAF3	50 (37)	24 (¹⁵ / ₁₆)	35* (26*)	21 (¹³ / ₁₆)	50 (37)	17 (²¹ / ₃₂)	30** (22**)	12 (¹⁵ / ₃₂)
JA5-JAF5	80 (59)	32 (1 ¹ / ₄)	35* (26*)	21 (¹³ / ₁₆)	80 (59)	22 (⁷ / ₈)	30** (22**)	12 (¹⁵ / ₃₂)
JA7	120 (88)	36 (1 ¹³ / ₃₂)	30** (22**)	12 (¹⁵ / ₃₂)	70 (51)	17 (²¹ / ₃₂)	30** (22**)	12 (¹⁵ / ₃₂)
JA7.2	400 (290)	70 (2 ³ / ₄)	30** (22**)	12 (¹⁵ / ₃₂)	110 (81)	22 (⁷ / ₈)	40** (29**)	14 (⁹ / ₁₆)
JA7.5	600 (440)	85 (3 ¹¹ / ₃₂)	40** (29**)	14 (⁹ / ₁₆)	160 (115)	24 (¹⁵ / ₁₆)	40** (29**)	14 (⁹ / ₁₆)
JA8	800 (590)	105 (4 ¹ / ₈)	40** (29**)	14 (⁹ / ₁₆)	250 (185)	32 (1 ¹ / ₄)	40** (29**)	14 (⁹ / ₁₆)

* Optional for JA3/JAF3/JA5/JAF5

(1 N·m ≈ 10 kg·cm)

** Torque values with sealing tape wrapped 3-3.5 turns around the threads

NOTE: - Coat all threaded portions with anti-seize.

- If drawings or other special documentation were supplied for the product, any torque given there takes precedence over values shown here.

Exploded View

JA3•JAF3 / JA5•JAF5

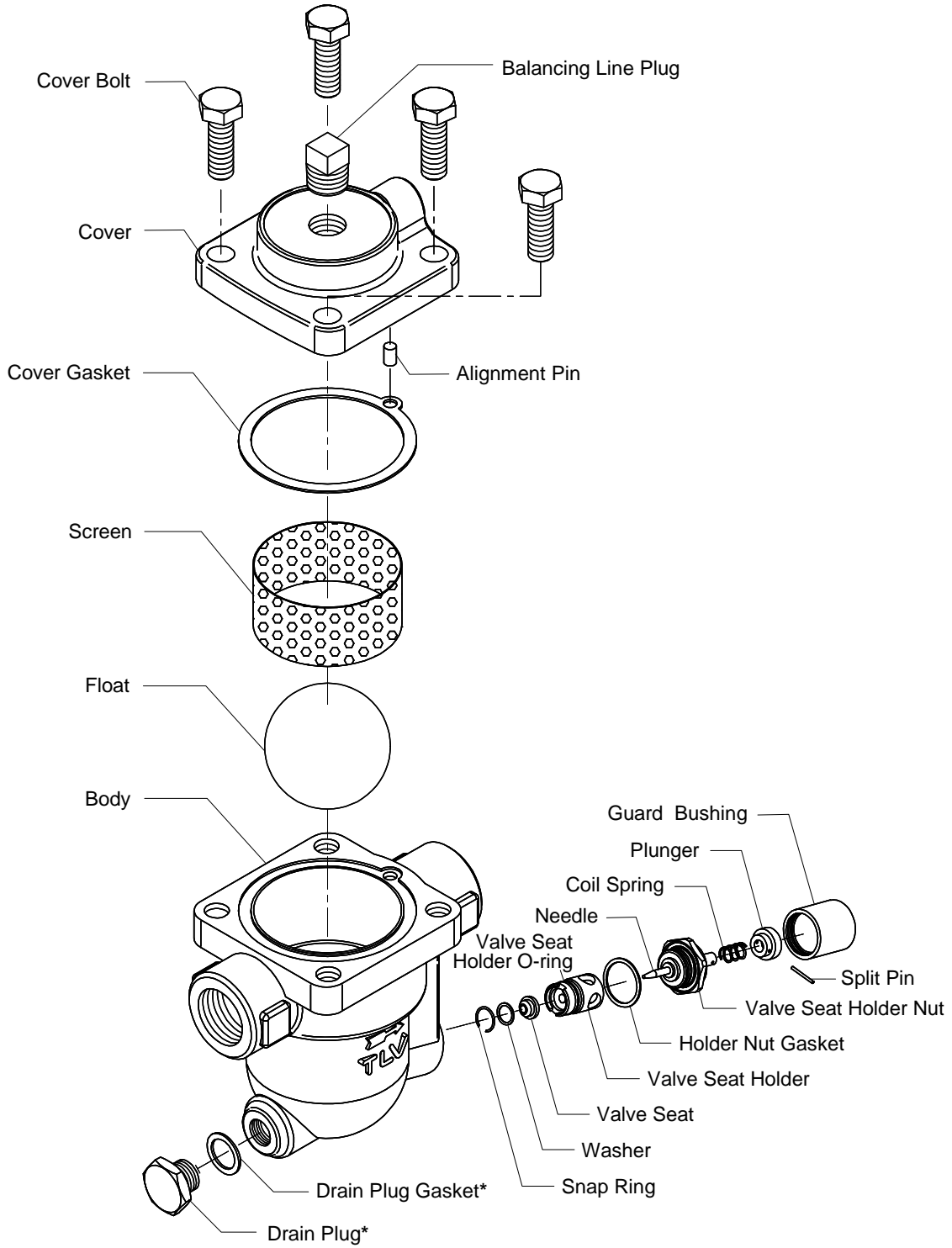

*Option

JA7 / JA7.2 / JA7.5 / JA8

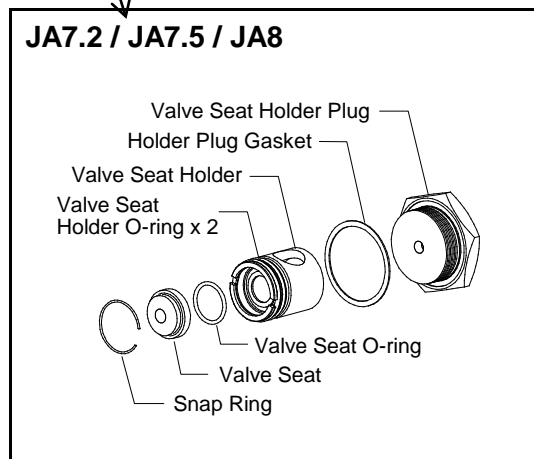
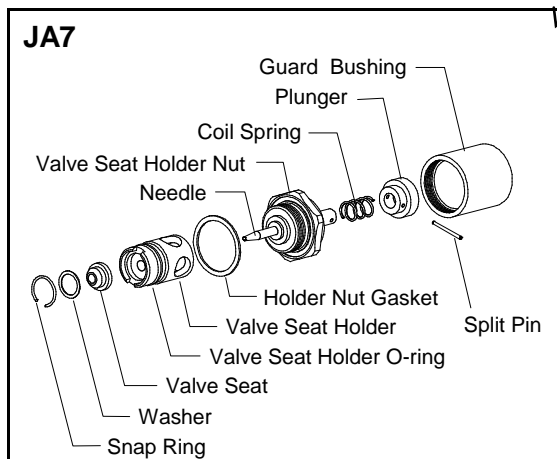
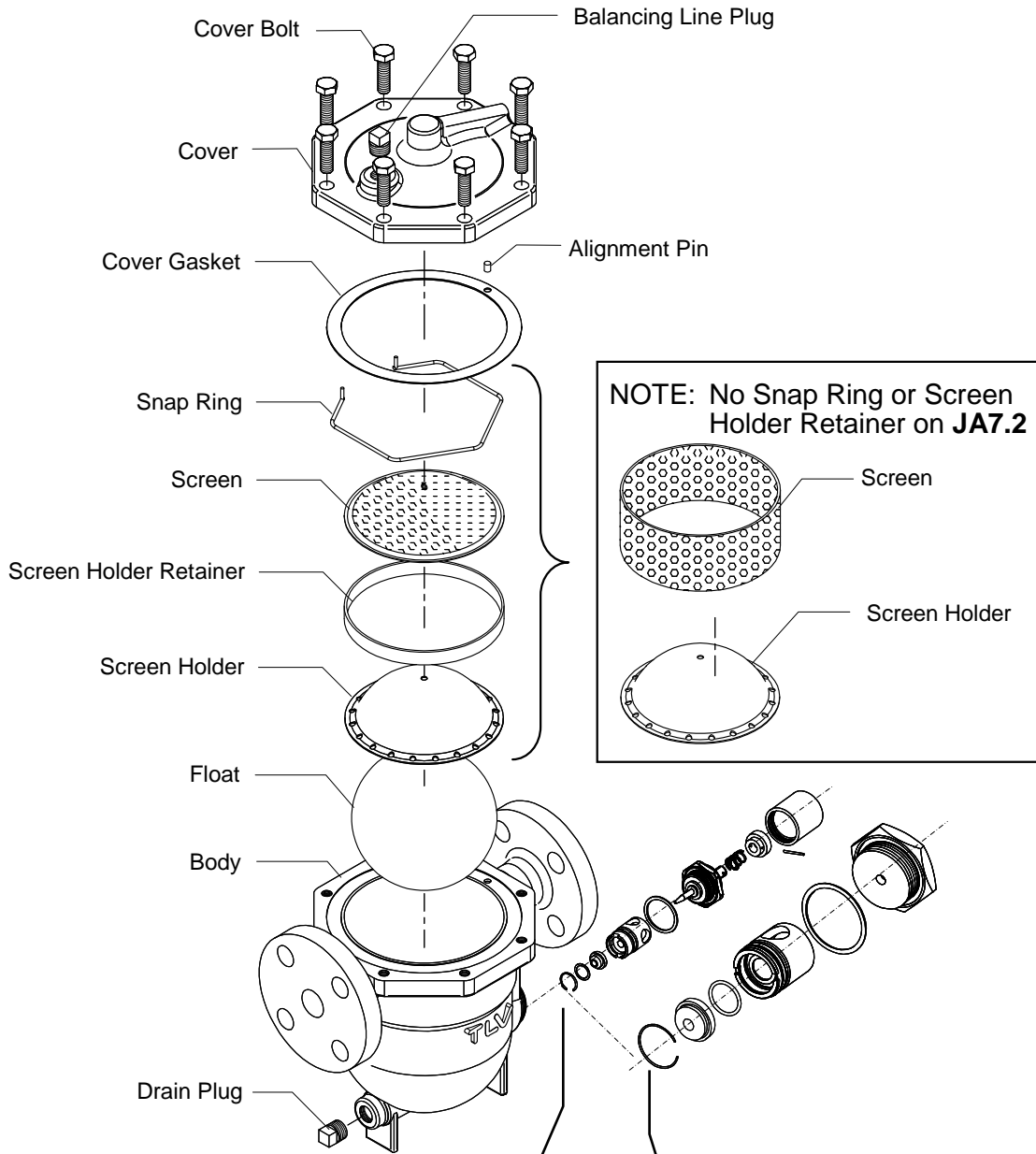

Troubleshooting



NEVER apply direct heat to the float. The float may explode due to increased internal pressure, causing accidents leading to serious injury or damage to property and equipment.



When disassembling or removing the product, wait until the internal pressure equals atmospheric pressure and the surface of the product has cooled to room temperature. Disassembling or removing the product when it is hot or under pressure may lead to discharge of fluids, causing burns, other injuries or damage.

If the trap fails to operate properly, use the following table to locate the cause and remedy.

Problem	Cause	Remedy
No condensate is discharged (blocked) or discharge is poor	The float is damaged or filled with condensate	Replace with a new float
	The valve seat opening, screen or piping are clogged with rust and scale	Clean parts; where available, use the needle to clean the valve seat opening* ²
	The trap operating pressure exceeds the maximum specified pressure or there is insufficient pressure differential between the trap inlet and outlet	Compare specifications and actual operating conditions
	Air binding has occurred	Make sure a pressure-balancing line is installed; if already installed, make sure it has not become dislodged or is not incorrectly installed
Air is discharged or leaks from the outlet* ¹ (blowing) (air leakage)	Build-up on the seating surface of the valve seat or rust and scale build-up beneath the float	Clean parts; where available, use the needle to clean the valve seat opening* ²
	Damage to the valve seat	Replace with a new valve seat
	The float is misshapen or has surface build-up	Clean float or replace with a new float
	Improper installation orientation	Correct the installation
	Trap vibration	Lengthen inlet piping and fasten securely
	There is no condensate in the air trap body, no water seal around the valve seat	Prime the air trap
Air is leaking from a place other than the outlet	Gasket deterioration or damage	Replace with new gasket(s)
	Improper tightening torques were used	Tighten to the proper torque
	There are scratches on the sealing surfaces	If leaking continues even after replacing the gasket, replace the product
Float frequently becomes damaged	Water hammer has occurred	Study and correct the piping

*¹ JA7.2/JA7.5/JA8: Make sure to maintain the Minimum Required Condensate Load, as air leaks may result if the inflowing condensate load falls below it.
(See the "Minimum Required Condensate Load" in the "Specifications" section.)

*² JA3•JAF3/JA5•JAF5/JA7: These models are equipped with a device that allows the valve to be forcibly opened from the outside of the trap.

If an oil clog occurs, activate the plunger by pushing it in several times with a fingertip.

The needle forces the float off of the valve seat. This results in the valve opening, which allows the discharge of any foreign matter or oil, thus remedying the problem.

When the finger is removed from the plunger, the force of the coil spring causes the plunger to return to its original position.

Product Warranty

1. Warranty Period
One year following product delivery.
2. Warranty Coverage
TLV CO., LTD. warrants this product to the original purchaser to be free from defective materials and workmanship. Under this warranty, the product will be repaired or replaced at our option, without charge for parts or labor.
3. This product warranty will not apply to cosmetic defects, nor to any product whose exterior has been damaged or defaced; nor does it apply in the following cases:
 - 1) Malfunctions due to improper installation, use, handling, etc., by other than TLV CO., LTD. authorized service representatives.
 - 2) Malfunctions due to dirt, scale, rust, etc.
 - 3) Malfunctions due to improper disassembly and reassembly, or inadequate inspection and maintenance by other than TLV CO., LTD. authorized service representatives.
 - 4) Malfunctions due to disasters or forces of nature.
 - 5) Accidents or malfunctions due to any other cause beyond the control of TLV CO., LTD.
4. Under no circumstances will TLV CO., LTD. be liable for consequential economic loss damage or consequential damage to property.

* * * * *

For Service or Technical Assistance:

Contact your **TLV** representative or your regional **TLV** office.

Manufacturer

TLV CO., LTD.
881 Nagasuna, Noguchi
Kakogawa, Hyogo 675-8511 JAPAN
Tel: 81-(0)79 - 427 - 1800