



Manufacturer

TLV CO., LTD.

Kakogawa, Japan

is approved by LRQA LTD. to ISO 9001/14001



Instruction Manual

Free Ball-Bucket Steam Trap
UFO3-BN • UFO3F-BN

Copyright © 2015 by TLV CO., LTD.

All rights reserved

Contents

Introduction	1
Safety Considerations	2
Checking the Piping	4
Operation	5
Specifications	6
Configuration	6
Installation	7
Maintenance.....	8
Disassembly / Reassembly	9
Troubleshooting	11
Product Warranty	12
Option: Insulation Cover.....	13

Introduction

Thank you for purchasing the **TLV** Free Ball-Bucket Steam Trap.

This product has been thoroughly inspected before being shipped from the factory. When the product is delivered, before doing anything else, check the specifications and external appearance to make sure nothing is out of the ordinary. Also be sure to read this manual carefully before use and follow the instructions to be sure of using the product properly.

The Free Ball-Bucket Steam Trap is suitable for applications where there is a possibility of steam-locking or for batch process equipment, such as heat exchangers, heaters, cylinder dryers and pressing machines.





If detailed instructions for special order specifications or options not contained in this manual are required, please contact **TLV** for full details.

This instruction manual is intended for use with the model(s) listed on the front cover. It is necessary not only for installation but for subsequent maintenance, disassembly/reassembly and troubleshooting. Please keep it in a safe place for future reference.

Safety Considerations

- Read this section carefully before use and be sure to follow the instructions.
- Installation, inspection, maintenance, repairs, disassembly, adjustment and valve opening/closing should be carried out only by trained maintenance personnel.
- The precautions listed in this manual are designed to ensure safety and prevent equipment damage and personal injury. For situations that may occur as a result of erroneous handling, three different types of cautionary items are used to indicate the degree of urgency and the scale of potential damage and danger: DANGER, WARNING and CAUTION.
- The three types of cautionary items above are very important for safety: be sure to observe all of them as they relate to installation, use, maintenance, and repair. Furthermore, TLV accepts no responsibility for any accidents or damage occurring as a result of failure to observe these precautions.

Symbols

	Indicates a DANGER, WARNING or CAUTION item.
	Indicates an urgent situation which poses a threat of death or serious injury
	Indicates that there is a potential threat of death or serious injury
	Indicates that there is a possibility of injury or equipment / product damage
	<p>Install properly and DO NOT use this product outside the recommended operating pressure, temperature and other specification ranges. Improper use may result in such hazards as damage to the product or malfunctions that may lead to serious accidents. Local regulations may restrict the use of this product to below the conditions quoted.</p> <p>DO NOT use this product in excess of the maximum operating pressure differential. Such use could make discharge impossible (blocked).</p> <p>Take measures to prevent people from coming into direct contact with product outlets. Failure to do so may result in burns or other injury from the discharge of fluids.</p> <p>When disassembling or removing the product, wait until the internal pressure equals atmospheric pressure and the surface of the product has cooled to room temperature. Disassembling or removing the product when it is hot or under pressure may lead to discharge of fluids, causing burns, other injuries or damage.</p>

Safety considerations continued on next page.



Be sure to use only the recommended components when repairing the product, and NEVER attempt to modify the product in any way.

Failure to observe these precautions may result in damage to the product and burns or other injury due to malfunction or the discharge of fluids.

Do not use excessive force when connecting threaded pipes to the product.

Over-tightening may cause breakage leading to fluid discharge, which may cause burns or other injury.

Use only under conditions in which no freeze-up will occur.

Freezing may damage the product, leading to fluid discharge, which may cause burns or other injury.

Use only under conditions in which no water hammer will occur.

The impact of water hammer may damage the product, leading to fluid discharge, which may cause burns or other injury.

Checking the Piping



Use only under conditions in which no water hammer will occur. The impact of water hammer may damage the product, leading to fluid discharge, which may cause burns or other injury.

Check to make sure that the pipes to be connected to the trap have been installed properly.

1. Is the pipe diameter suitable?
2. Is the piping where the trap is to be installed horizontal?
3. Has sufficient space been secured for maintenance?
4. Have isolation valves been installed at the inlet and outlet? If the outlet is subject to back pressure, has a check valve (TLV-CK) been installed?
5. Is the inlet pipe as short as possible, with as few bends as possible, and installed so the liquid will flow naturally down into the trap?
6. Has the piping work been done correctly, as shown in the figures below?

Requirement	Correct	Incorrect
Install catchpot with the proper diameter.		 Diameter is too small.
Make sure the flow of condensate is not obstructed.		 Diameter is too small and inlet protrudes into pipe interior.
To prevent rust and scale from flowing into the trap, the inlet pipe should be connected 25 – 50 mm above the base of the T-pipe.		 Rust and scale flow into the trap with the condensate.
When installing on the blind end, make sure the flow of condensate is not obstructed.		 Condensate collects in the pipe.

Operation

Principles of air and condensate discharge:

1. Start-up Air and Cold Condensate Discharge

At start-up, The UFO is on the launching pad and initial air is discharged. When air flows in with cold condensate, the UFO floats off of the launching pad. However, the bimetal is contracted due to the low temperature. This holds the UFO away, preventing it from closing against the drain-jet allowing the discharge of all initial air and cold condensate.

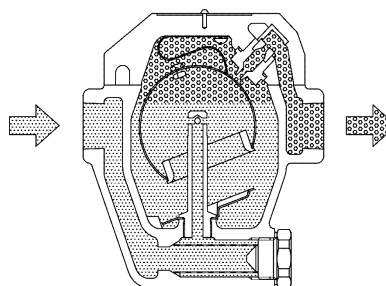
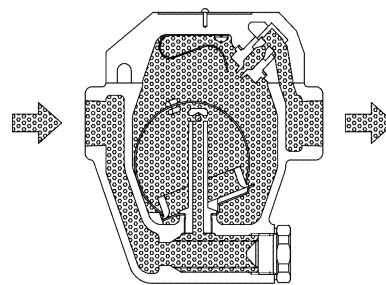

2. Entry of Steam

When steam flows in, the higher temperature causes the bimetal to expand, releasing the UFO. This allows the UFO to float up and close off the drain-jet.

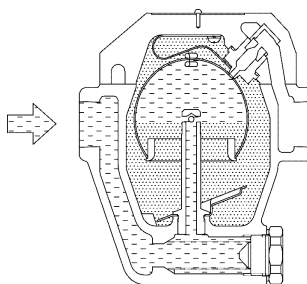

3. Entry and Discharge of Condensate

As hot condensate enters replacing the steam, the UFO loses buoyancy and sinks back down to the launching pad, allowing condensate discharge through the drain-jet. When steam flows in again, the UFO will once more rise and close off the drain-jet.

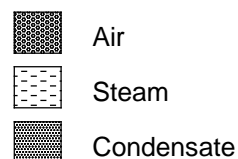
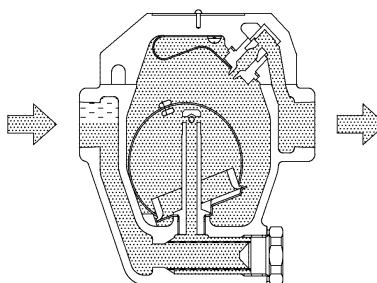

Specifications



Install properly and **DO NOT** use this product outside the recommended operating pressure, temperature and other specification ranges. Improper use may result in such hazards as damage to the product or malfunctions which may lead to serious accidents. Local regulations may restrict the use of this product to below the conditions quoted.



DO NOT use this product in excess of the maximum operating pressure differential; such use could make discharge impossible (blocked).



Use only under conditions in which no freeze-up will occur. Freezing may damage the product, leading to fluid discharge, which may cause burns or other injury.

Refer to the product nameplate for detailed specifications.

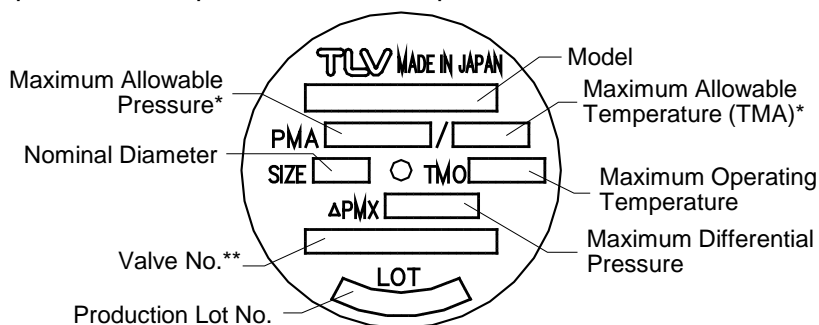

* Maximum allowable pressure (PMA) and maximum allowable temperature (TMA) are **PRESSURE SHELL DESIGN CONDITIONS, NOT OPERATING CONDITIONS.**

** Tag No. is displayed for products with options. This item is omitted from the nameplate when there are no options.

Configuration

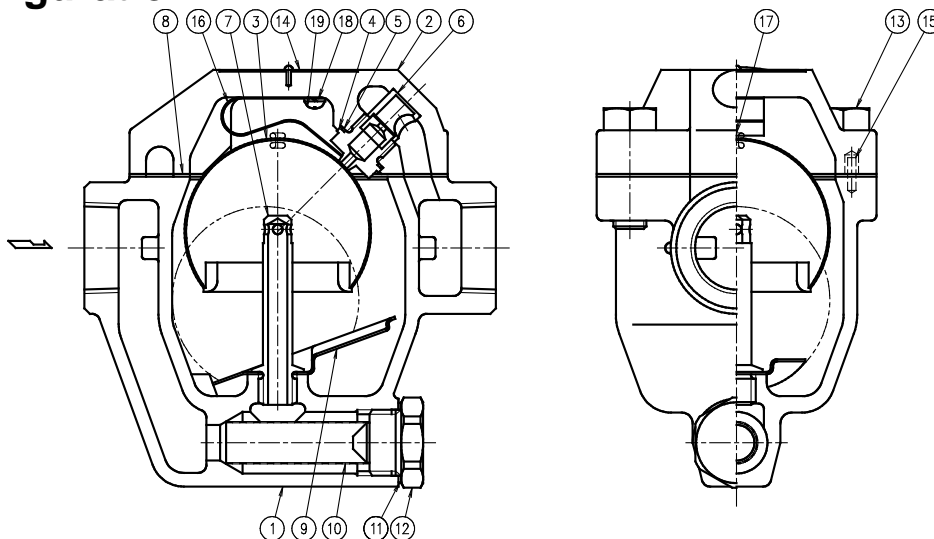

No.	Name	M	R	U	No.	Name	M	R	No.	Name	M	R	U
1	Case				8	Cover Gasket	✓	✓	15	Guide Pin			
2	Cover				9	Launching Pad			16	Bimetal Strip		✓	
3	UFO Ball-bucket			✓	10	Screen		✓	17	Pin			✓
4	Drain-jet		✓		11	Screen Holder Gasket	✓	✓	18	Spring Washer		✓	
5	Drain-jet Gasket	✓	✓		12	Screen Holder			19	Screw			✓
6	Bushing				13	Cover Bolt							
7	Blast-off Nozzle				14	Nameplate							

Replacement parts are available only in the following kits: M = Maintenance Kit; R = Repair Kit; U = UFO kit

Installation



Install properly and **DO NOT** use this product outside the recommended operating pressure, temperature and other specification ranges. Improper use may result in such hazards as damage to the product or malfunctions which may lead to serious accidents. Local regulations may restrict the use of this product to below the conditions quoted.



Take measures to prevent people from coming into direct contact with product outlets. Failure to do so may result in burns or other injury from the discharge of fluids.



Do not use excessive force when connecting threaded pipes to the product. Over-tightening may cause breakage leading to fluid discharge, which may cause burns or other injury.

Installation, inspection, maintenance, repairs, disassembly, adjustment and valve opening/closing should be carried out only by trained maintenance personnel.

1. Before installation, be sure to remove all protective seals.
2. Before installing the product, open the inlet valve and blow out the piping to remove any piping scraps, dirt and oil. Close the inlet valve after blowdown.
3. Install the product so the arrow on the body is pointing in the direction of flow.
4. The trap should be inclined no more than 5° horizontally and front-to-back.
5. Install a condensate outlet valve and outlet piping.
6. Open the inlet and outlet valves and check to make sure that the product functions properly.

If there is a problem, determine the cause using the “Troubleshooting” section in this manual.

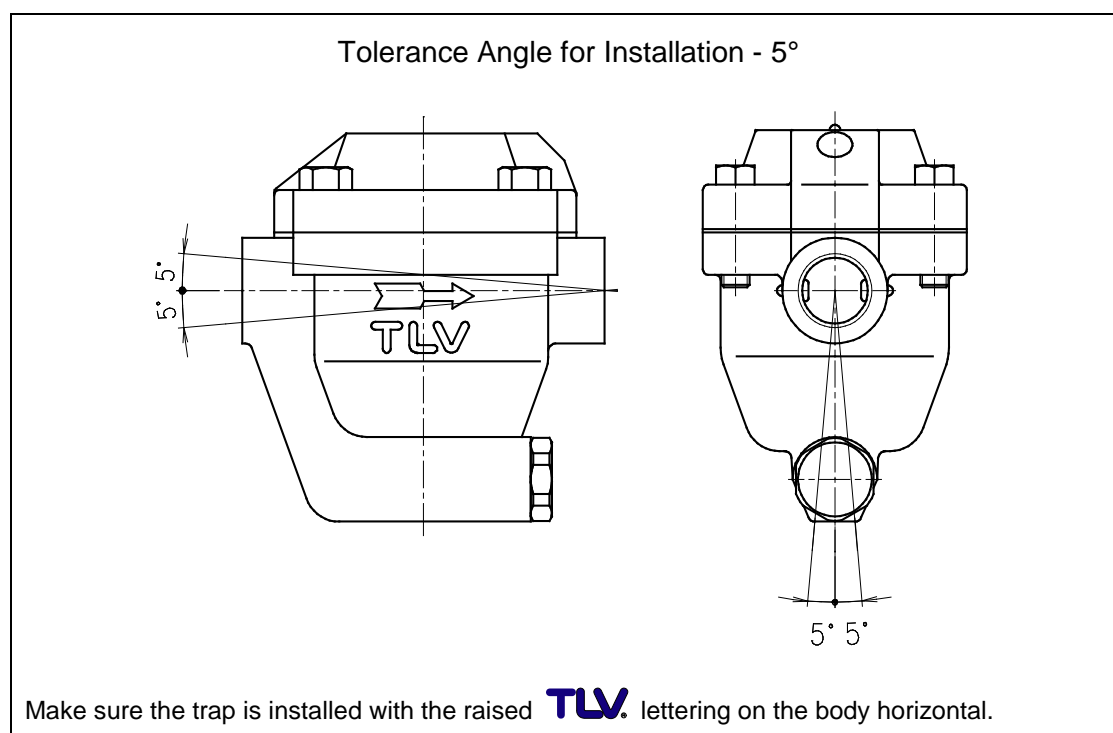

Maintenance



Take measures to prevent people from coming into direct contact with product outlets. Failure to do so may result in burns or other injury from the discharge of fluids.



Be sure to use only the recommended components when repairing the product, and NEVER attempt to modify the product in any way. Failure to observe these precautions may result in damage to the product or burns or other injury due to malfunction or the discharge of fluids.

Operational Check

A visual inspection of the following items should be done on a daily basis to determine whether the trap is operating properly or has failed. Periodically (at least biannually) the operation should also be checked by using diagnostic equipment, such as a stethoscope, thermometer or TLV Pocket TrapMan or TLV TrapMan.

If the trap should fail, it may cause damage to piping and equipment, resulting in faulty or low quality products or losses due to steam leakage.

- Normal : Condensate, together with flash steam, is discharged intermittently, and the sound of flow can be heard at the time of discharge.
- Blocked (Discharge Impossible) : No condensate is discharged. The trap is quiet and makes no noise, and the surface temperature of the trap is low.
- Blowing : Live steam continually flows from the outlet and there is a continuous metallic sound.
- Steam Leakage : Live steam is discharged through the trap outlet together with condensate, accompanied by a high-pitched sound.

(When conducting a visual inspection, flash steam is sometimes mistaken for steam leakage. For this reason, the use of a steam trap diagnostic instrument [TLV: TrapMan] in conjunction with the visual inspection is highly recommended.)

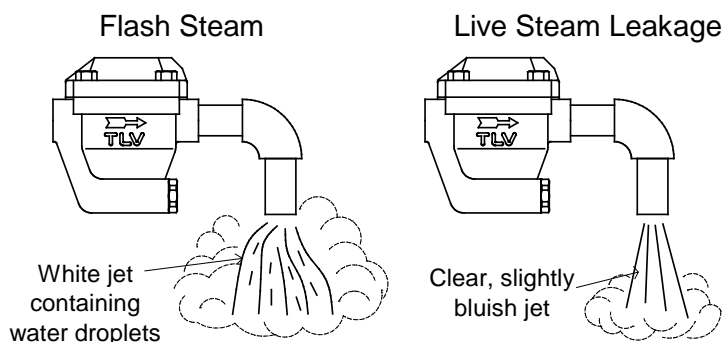

Parts Inspection

When parts have been removed, or during periodic inspections, use the following table to inspect the parts and replace any that are found to be defective.

Procedure
Gaskets: check for warping or scratches
Screen: check for clogging or corrosion
Drain-jet: Check for damage
UFO Ball-bucket: check for scratches or dents

Disassembly / Reassembly



When disassembling or removing the product, wait until the internal pressure equals atmospheric pressure and the surface of the product has cooled to room temperature. Disassembling or removing the product when it is hot or under pressure may lead to discharge of fluids, causing burns, other injuries or damage.



Be sure to use only the recommended components when repairing the product, and NEVER attempt to modify the product in any way. Failure to observe these precautions may result in damage to the product or burns or other injury due to malfunction or the discharge of fluids.

Use the following procedures to remove components. Use the same procedures in reverse to reassemble. (Installation, inspection, maintenance, repairs, disassembly, adjustment and valve opening/closing should be carried out only by trained maintenance personnel.)

Detaching / Reattaching the Cover

Part	During Disassembly	During Reassembly
Cover Bolt	Remove with a socket wrench	Consult the table of tightening torques and tighten to the proper torque
Cover	Lift up the cover; remove, being careful not to damage the seating surface	Make sure there are no pieces of the old gasket left on the seating surfaces; make sure the arrow points in the direction of condensate flow
Cover Gasket	Remove, being careful not to damage the seating surface and clean the seating surface	Replace with a new gasket

Disassembly / Reassembly of Components Inside the Cover

Part	During Disassembly	During Reassembly
Bimetal Strip	Remove with a screwdriver; being careful not to bend the bimetal strip	Consult the table of tightening torques and tighten to the proper torque, being careful not to bend the bimetal strip
Drain-jet	Remove with a socket wrench	Consult the table of tightening torques and tighten to the proper torque
Drain-jet Gasket	Remove the gasket and clean the seating surface	Replace with a new gasket if warped or damaged

Disassembly / Reassembly of Screen Parts

Part	During Disassembly	During Reassembly
Screen Holder	Remove with a socket wrench	Consult the table of tightening torques and tighten to the proper torque
Screen Holder Gasket	Remove the gasket and clean sealing surfaces	Replace with a new gasket; coat surfaces with anti-seize
Screen	Remove without bending	Reinsert without bending

Disassembly / Reassembly of Components Inside the Body

Part	During Disassembly	During Reassembly
UFO Ball-bucket	Use needle-nose pliers to grasp the UFO by the pin on the top and lift up to remove	Insert, being careful not to mishape the UFO ball-bucket

Table of Tightening Torques

Part Name	Torque		Dist. Across Flats	
	N·m	(lbf·ft)	mm	(in)
Cover Bolt	30	(22)	13	(¹ / ₂)
Drain Jet	15	(11)	13	(¹ / ₂)
Screen Holder	60	(44)	22	(⁷ / ₈)
Screw (for Bimetal Strip)	0.3	(0.22)	+	

(1 N·m ≈ 10 kg·cm)

NOTE: -Coat all threaded portions and orifice gasket with anti-seize.

-If drawings or other special documentation were supplied for the product, any torque given there takes precedence over values shown here.

Exploded View

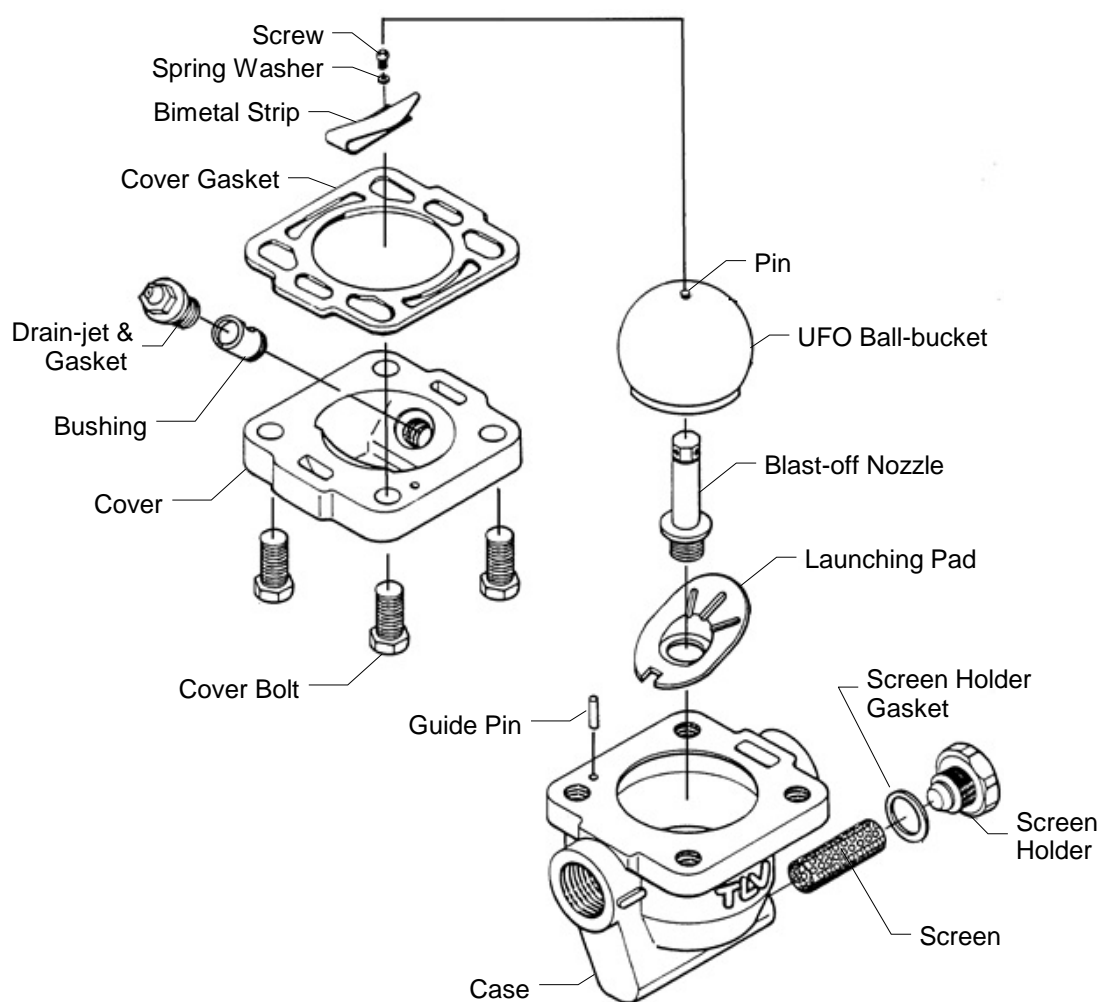

Troubleshooting



When disassembling or removing the product, wait until the internal pressure equals atmospheric pressure and the surface of the product has cooled to room temperature. Disassembling or removing the product when it is hot or under pressure may lead to discharge of fluids, causing burns, other injuries or damage.

If the product fails to operate properly, use the following table to locate and remedy the cause.

Problem	Cause	Remedy
No condensate is discharged (blocked) or discharge is poor	The UFO ball-bucket is stuck to the drain-jet	Clean Parts
	The drain-jet valve port, screen or piping is clogged with rust or scale	Clean parts
	The steam trap has an insufficient capacity	Compare specifications with actual operating conditions
	The trap operating pressure exceeds the maximum specified pressure, or whether there is insufficient pressure differential between the trap inlet and outlet	Compare specifications and actual operating conditions
	Steam-locking has occurred	Perform a bypass blowdown or close the trap inlet piping and allow the trap to cool
Steam is discharged or leaks from the outlet (blowing) (steam leakage)	Build-up of rust or scale on the drain-jet valve port or on the UFO ball-bucket surface	Clean parts
	Drain-jet is damaged	Replace with a new drain-jet
	The UFO ball-bucket is misshapen or damaged	Replace with a new UFO ball-bucket
	Improper installation orientation	Correct the installation
	The bimetal strip is damaged	Replace with a new bimetal strip
Trap vibration	Lengthen the inlet piping and fasten it securely	
Steam is leaking from a place other than the outlet	Gasket deterioration or damage	Replace with new gasket(s)
	Improper tightening torques were used	Tighten to the proper torque

NOTE: -Blowing may occur on bucket-type steam traps used at less than 10% of their maximum discharge capacity. Therefore, do not use this trap for applications in which only small quantities of condensate are produced.

-When replacing parts with new, use the parts list for reference, and replace with parts from the Maintenance kit, Repair kit, etc. Please note that replacement parts are only available as part of a replacement parts kit.

Product Warranty

1. Warranty Period
One year following product delivery.
2. Warranty Coverage
TLV CO., LTD. warrants this product to the original purchaser to be free from defective materials and workmanship. Under this warranty, the product will be repaired or replaced at our option, without charge for parts or labor.
3. This product warranty will not apply to cosmetic defects, nor to any product whose exterior has been damaged or defaced; nor does it apply in the following cases:
 - 1) Malfunctions due to improper installation, use, handling, etc., by other than TLV CO., LTD. authorized service representatives.
 - 2) Malfunctions due to dirt, scale, rust, etc.
 - 3) Malfunctions due to improper disassembly and reassembly, or inadequate inspection and maintenance by other than TLV CO., LTD. authorized service representatives.
 - 4) Malfunctions due to disasters or forces of nature.
 - 5) Accidents or malfunctions due to any other cause beyond the control of TLV CO., LTD.
4. Under no circumstances will TLV CO., LTD. be liable for consequential economic loss damage or consequential damage to property.

* * * * *

For Service or Technical Assistance:

Contact your **TLV** representative or your regional **TLV** office.

Manufacturer

TLV CO., LTD.
881 Nagasuna, Noguchi
Kakogawa, Hyogo 675-8511 JAPAN
Tel: 81-(0)79 - 427 - 1800

Option: Insulation Cover



When disassembling or removing the product, wait until the internal pressure equals atmospheric pressure and the surface of the product has cooled to room temperature. Disassembling or removing the product when it is hot or under pressure may lead to discharge of fluids, causing burns, other injuries or damage.

One insulation cover set consists of a soft ceramic fiber case and 2 binding straps.

Use the following procedures to install the insulation cover. (Installation, inspection, maintenance, repairs, disassembly, adjustment and valve opening/closing should be carried out only by trained maintenance personnel.)

Attaching the Insulation Cover to the Steam Trap

1. Allow the trap to cool to ambient temperature.
2. Open the cover along the Velcro strip.
3. Place cover evenly around the body with the arrow on the cover facing the same direction as the arrow on the trap body.
4. Reattach the Velcro strip.
5. Secure the ends of the cover around the trap inlet and outlet with the binding straps.

Applicable insulation cover for UFO3-BN/UFO3F-BN: RK3

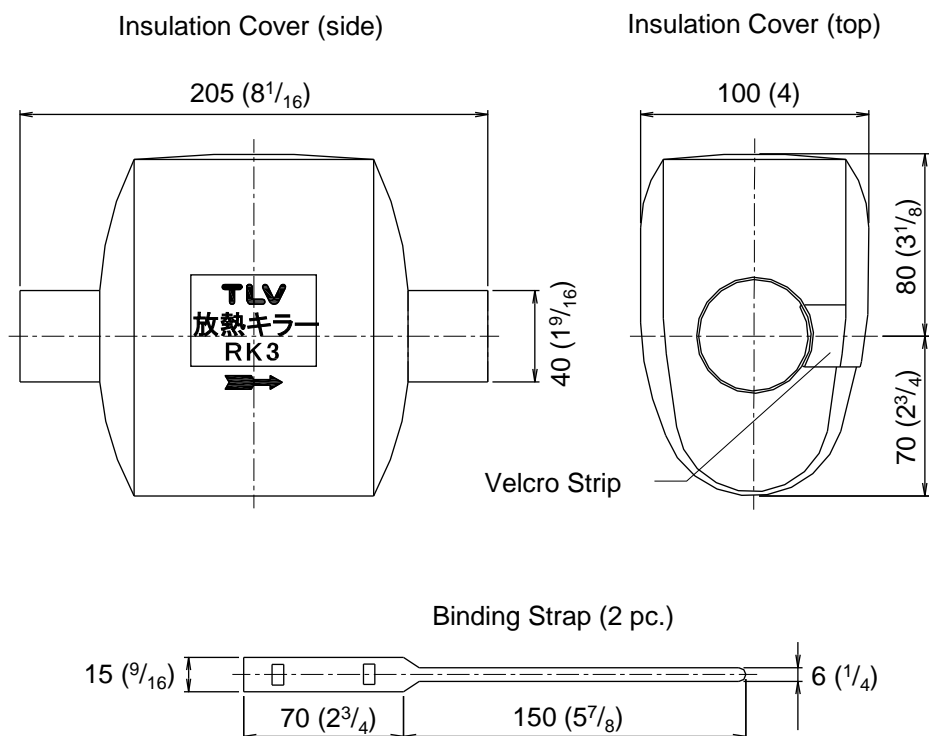

Thickness: 0.2 (0.008)

Unit: mm (in)