



Manufacturer
TLV. CO., LTD.

Kakogawa, Japan

is approved by LRQA LTD. to ISO 9001/14001



Instruction Manual

Thermodyne Steam Trap
A46S / A46SW / A65S

Copyright © 2010 by TLV CO., LTD.
All rights reserved

Contents

Introduction	1
Safety Considerations	2
Checking the Piping	4
Specifications	5
Configuration	5
Operation	6
Installation	7
Maintenance.....	8
Disassembly / Reassembly	9
Troubleshooting	11
Product Warranty	12
Options.....	13

Introduction

Thank you for purchasing the **TLV** Thermodyne Steam Trap.

This product has been thoroughly inspected before being shipped from the factory. When the trap is delivered, before doing anything else, check the specifications and external appearance to make sure nothing is out of the ordinary. Also be sure to read this manual carefully before use and follow the instructions to be sure of using the trap properly.

The Thermodyne Steam Trap features a bimetal ring for thermostatic air venting, which allows the quick, automatic discharge of large quantities of initial air and cold condensate immediately after operation start-up, thereby greatly reducing start-up time. It also reacts with great sensitivity to the inflow of large quantities of condensate and hot air during operation, preventing air binding.

The Thermodyne Steam Trap, with its superior features listed above, in combination with the proven performance record of the bimetal thermostatic air vent, increases heating efficiency and reduces manpower requirements for maintenance and bypass blowdown.

If detailed instructions for special order specifications or options not contained in this manual are required, please contact **TLV** for full details.

This instruction manual is intended for use with the models listed on the front cover. It is necessary not only for installation but for subsequent maintenance, disassembly/reassembly and troubleshooting. Please keep it in a safe place for future reference.

Safety Considerations

- Read this section carefully before use and be sure to follow the instructions.
- Installation, inspection, maintenance, repairs, disassembly, adjustment, and valve opening/closing should be carried out only by trained maintenance personnel.
- The precautions listed in this manual are designed to ensure safety and prevent equipment damage and personal injury. For situations that may occur as a result of erroneous handling, three different types of cautionary items are used to indicate the degree of urgency and the scale of potential damage and danger: DANGER, WARNING and CAUTION.
- The three types of cautionary items above are very important for safety: be sure to observe all of them as they relate to installation, use, maintenance, and repair. Furthermore, TLV accepts no responsibility for any accidents or damage occurring as a result of failure to observe these precautions.

Symbols

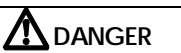
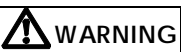
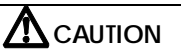
	Indicates a DANGER, WARNING or CAUTION item.
 DANGER	Indicates an urgent situation which poses a threat of death or serious injury
 WARNING	Indicates that there is a potential threat of death or serious injury
 CAUTION	Indicates that there is a possibility of injury or equipment / product damage

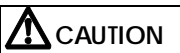
 CAUTION	<p>Install properly and DO NOT use this product outside the recommended operating pressure, temperature and other specification ranges. Improper use may result in such hazards as damage to the product or malfunctions that may lead to serious accidents. Local regulations may restrict the use of this product to below the conditions quoted.</p> <p>Take measures to prevent people from coming into direct contact with product outlets. Failure to do so may result in burns or other injury from the discharge of fluids.</p> <p>When disassembling or removing the product, wait until the internal pressure equals atmospheric pressure and the surface of the product has cooled to room temperature. Disassembling or removing the product when it is hot or under pressure may lead to discharge of fluids, causing burns, other injuries or damage.</p> <p>Be sure to use only the recommended components when repairing the product, and NEVER attempt to modify the product in any way. Failure to observe these precautions may result in damage to the product and burns or other injury due to malfunction or the discharge of fluids.</p>
---	---

Safety cautions continued on next page.

 CAUTION	Do not use excessive force when connecting threaded pipes to the product.
	Over-tightening may cause breakage leading to fluid discharge, which may cause burns or other injury.
	Use only under conditions in which no freeze-up will occur.
	Freezing may damage the product, leading to fluid discharge, which may cause burns or other injury.
	Use only under conditions in which no water hammer will occur.
	The impact of water hammer may damage the product, leading to fluid discharge, which may cause burns or other injury.

Checking the Piping



Use only under conditions in which no water hammer will occur. The impact of water hammer may damage the product, leading to fluid discharge, which may cause burns or other injury.

Check to make sure that the pipes to be connected to the trap have been installed properly.

1. Is the pipe diameter suitable?
2. Has sufficient space been secured for maintenance?
3. Have maintenance valves been installed at the inlet and outlet? If the outlet is subject to back pressure, has a check valve (TLV-CK) been installed?
4. Is the inlet pipe as short as possible, with as few bends as possible, and installed so the liquid will flow naturally down into the trap?
5. Has the piping work been done with the proper methods, shown in the figures below?

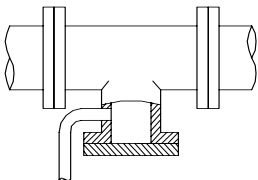
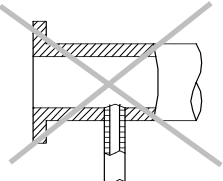
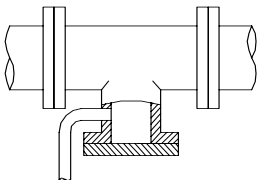
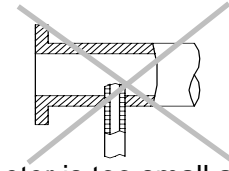
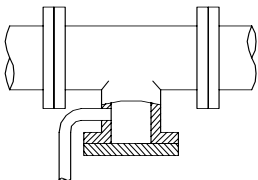
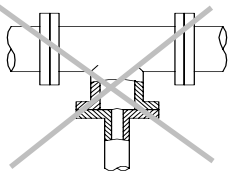
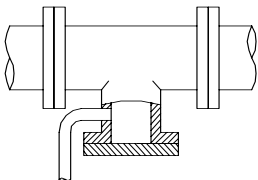
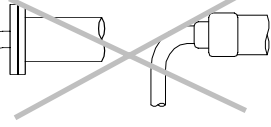
Requirement	Correct	Incorrect
Install catchpot with the proper diameter.		 Diameter is too small.
Make sure the flow of condensate is not obstructed.		 Diameter is too small and inlet protrudes into pipe interior.
To prevent rust and scale from flowing into the trap, the inlet pipe should be connected 25 – 50 mm (1 – 2 in) above the base of the T-pipe.		 Rust and scale flow into the trap with the condensate.
When installing on the blind end, make sure the flow of condensate is not obstructed.		 Condensate collects in the pipe.

Specifications

CAUTION Install properly and **DO NOT** use this product outside the recommended operating pressure, temperature and other specification ranges. Improper use may result in such hazards as damage to the product or malfunctions which may lead to serious accidents. Local regulations may restrict the use of this product to below the conditions quoted.

CAUTION Use only under conditions in which no freeze-up will occur. Freezing may damage the product, leading to fluid discharge, which may cause burns or other injury.

Refer to the product nameplate for detailed specifications.

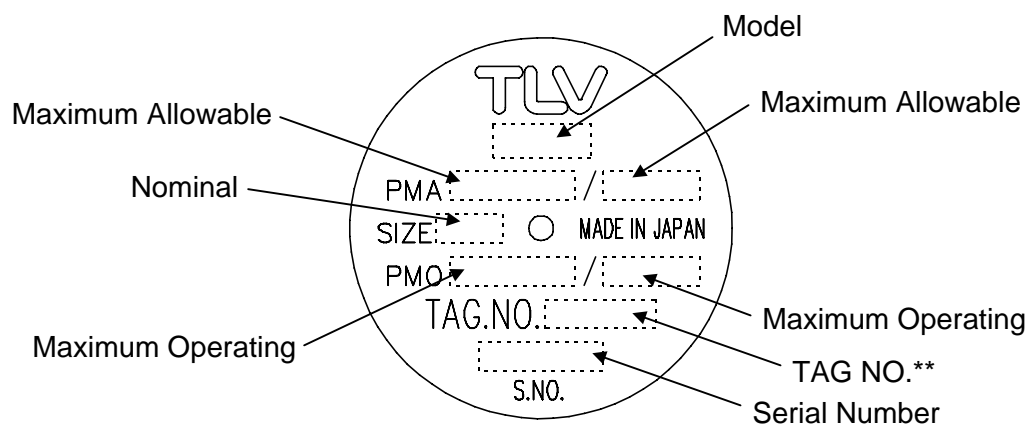

* Maximum allowable pressure (PMA) and maximum allowable temperature (TMA) are PRESSURE SHELL DESIGN CONDITIONS, **NOT** OPERATING CONDITIONS.

** TAG NO. is displayed for products with options. This item is omitted from the nameplate when there are no options.

Configuration

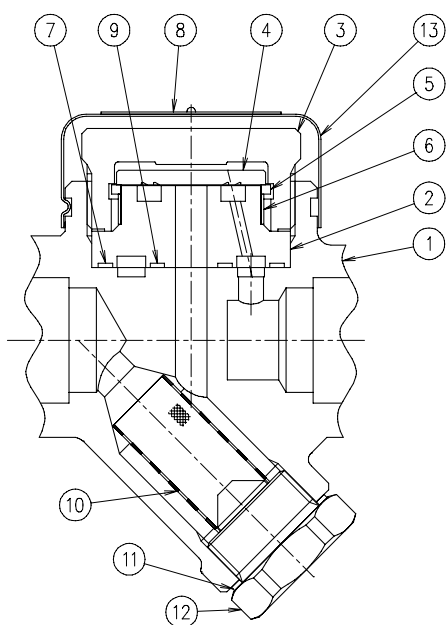

No.	Name	Maintenance Kit	Repair Kit
1	Body		
2	Module Valve Seat		√
3	Inner Cover		√
4	Disc		√
5	Disc Holder Ring		√
6	Air Vent Ring		√
7	Outer Module Gasket	√	√
8	Nameplate		
9	Inner Module Gasket	√	√
10	Screen		√
11	Screen Holder Gasket	√	√
12	Screen Holder		
13	Cap		

Operation

Principle of Air and Condensate Discharge

1. Start-up: Discharge of Initial Air and Cold Condensate

At start-up, the bimetal air vent ring is cold and has therefore contracted, causing it to ride up to the narrower area under the disc, thus lifting the disc off the seat and holding the valve open. This allows for the rapid discharge of initial air and cold condensate.

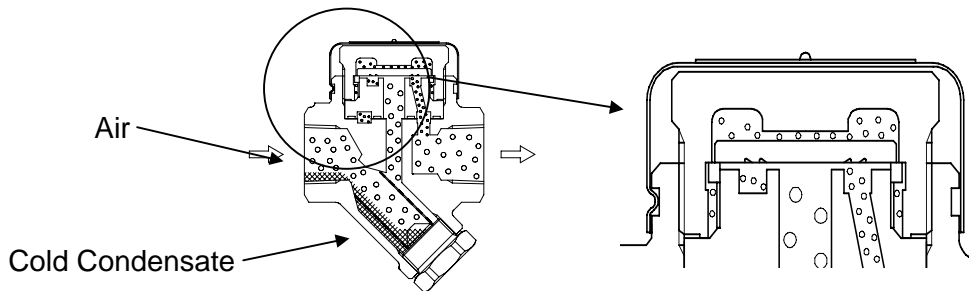

2. Steam Enters, Valve Closes

As the bimetal air vent ring is heated by the entering steam, it expands and slips back down, freeing the disc. The rapid flow of steam creates a low-pressure region under the disc, which suctions it onto the seat. The pressure chamber above the disc becomes a high pressure region when entering steam is compressed. This difference in the pressures above and below the disc gives the closed valve a tight seal.

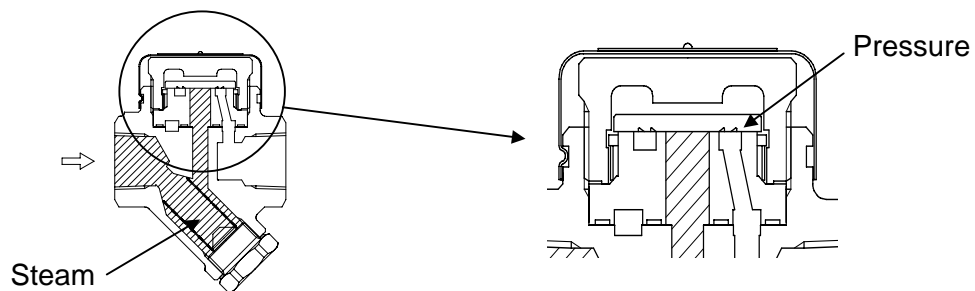

3. Condensate Discharge

When condensate enters the trap, the temperature in the pressure chamber drops, causing the steam to condense and the pressure to drop. The inlet pressure then pushes up the disc, opening the valve and allowing condensate to discharge. The bimetal air vent ring remains in its expanded, low position state. When steam again enters the trap, the valve closes, as in step 2, while allowing no steam to escape.

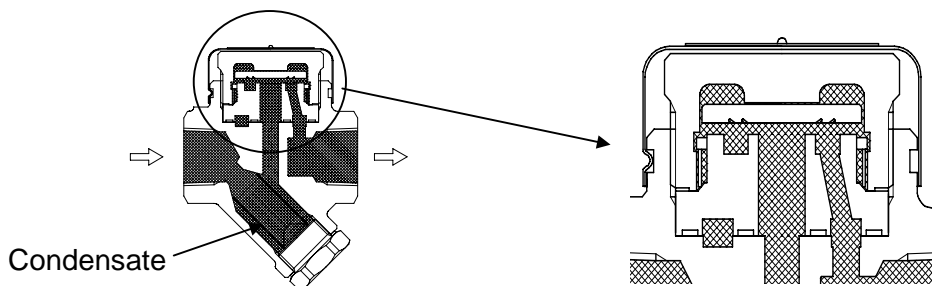

Installation



Take measures to prevent people from coming into direct contact with product outlets. Failure to do so may result in burns or other injury from the discharge of fluids.



Do not use excessive force when connecting threaded pipes to the product. Over-tightening may cause breakage leading to fluid discharge, which may cause burns or other injury.

Note: For products with socket weld connections, electric weld with a single pass. As internal parts are not damaged by the welding process if limited to a single pass, there is no need to remove them before welding.

Installation, inspection, maintenance, repairs, disassembly, adjustment and valve opening/closing should be carried out only by trained maintenance personnel.

1. Before installation, be sure to remove all protective seals.
2. Before installing the trap, blow out the inlet piping to remove any piping scraps, dirt and oil. Close the inlet valve after blowdown.
3. Install the trap so the arrow on the trap is pointing in the direction of condensate flow.
4. The trap may be installed either horizontally or vertically; there are no restrictions on the direction of installation. (Fix the trap securely in place.)
5. Connect the outlet piping.
6. Open the inlet valve and check to make sure that the trap functions properly.

If there is a problem, determine the cause by using the “Troubleshooting” section in this manual.

Maintenance



Take measures to prevent people from coming into direct contact with product outlets. Failure to do so may result in burns or other injury from the discharge of fluids.



Be sure to use only the recommended components when repairing the product, and NEVER attempt to modify the product in any way. Failure to observe these precautions may result in damage to the product or burns or other injury due to malfunction or the discharge of fluids.

Operational Check

A visual inspection of the items on the following page should be done on a daily basis to determine whether the trap is operating properly or has failed. Periodically (at least biannually) the operation should also be checked by using diagnostic equipment, such as a stethoscope, thermometer, TLV TrapMan or TLV Pocket TrapMan.

If the trap should fail, it may cause damage to piping and equipment, resulting in faulty or low quality products or losses due to steam leakage.

- Normal : Condensate is discharged intermittently together with flash steam, and the sound of flow can be heard.
- Blocked (Discharge Impossible) : No condensate is discharged. The trap is quiet and makes no noise, and the surface temperature of the trap is low.
- Blowing : Live steam continually flows from the outlet and there is a continuous metallic sound.
- Steam Leakage : Live steam is discharged through the trap outlet together with condensate, accompanied by a high-pitched sound.

(When conducting a visual inspection, flash steam is sometimes mistaken for steam leakage. For this reason, the use of a steam trap diagnostic instrument [TLV: TrapMan] in conjunction with the visual inspection is highly recommended.)

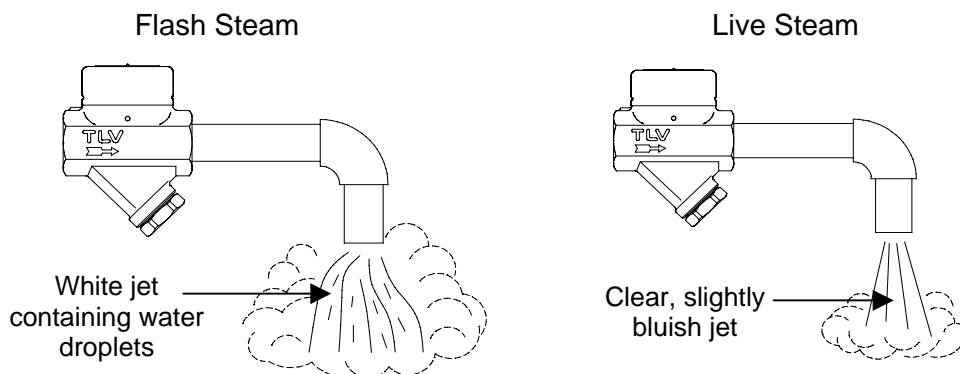

Parts Inspection

When parts have been removed, or during periodic inspections, use the following table to inspect the parts and replace any that are found to be defective.

Procedure
Gaskets: check for warping or damage
Screen: check for clogging or corrosion damage
Disc: check for damage or wear
Disc Holder Ring: check for damage or wear
Air Vent Ring: check for damage or wear
Module Valve Seat Surface: check for damage or wear

Disassembly / Reassembly



When disassembling or removing the product, wait until the internal pressure equals atmospheric pressure and the surface of the product has cooled to room temperature. Disassembling or removing the product when it is hot or under pressure may lead to discharge of fluids, causing burns, other injuries or damage.

Use the following procedures to remove components. Use the same procedures in reverse to reassemble.

(Installation, inspection, maintenance, repairs, disassembly, adjustment and valve opening/closing should be carried out only by trained maintenance personnel.)

Removing / Replacing the Cap

Figure A

Part	During Disassembly	During Reassembly
Cap	Gently turn the cap until the notch on the cap lines up with the knob on the body, then remove	Being careful not to bend it, gently turn the cap until the notch on the cap lines up with the knob on the body, then tighten (see Figure A)

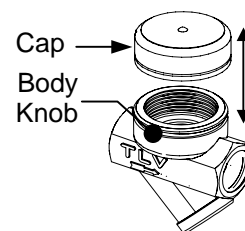

Removing / Replacing the Valve Seat Unit

Part	During Disassembly	During Reassembly
Inner Cover	Remove with a socket wrench	Consult the table of tightening torques and tighten to the proper torque
Disc	Remove, being careful not to scratch the lapped surface	Make sure that the seat surface (lapped side with groove) is facing down toward the valve seat (see Figure B)
Disc Holder Ring	Remove without bending	Set on the air vent ring and make sure that it does not sit on the valve seat surface
Air Vent Ring	Remove without bending, as it will not return to its proper shape	Reinsert without bending
Module Valve Seat	Remove carefully, being careful not to scratch the polished seat surface	Insert into the body levelly, being careful not to tilt
Outer Module Gasket	Remove with a screwdriver, or other suitable tool and clean the gasket housing	Replace with a new gasket
Inner Module Gasket	Remove with a screwdriver, or other suitable tool and clean the gasket housing	Replace with a new gasket

Figure B

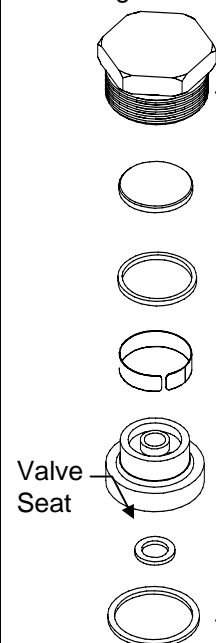

Removing / Replacing the Parts Inside the Body

Part	During Disassembly	During Reassembly
Screen Holder	Remove with a socket wrench	Consult the table of tightening torques and tighten to the proper torque
Screen Holder Gasket	—	Can be reused if not damaged, but replacement with a new gasket is recommended
Screen	Remove without bending	Reinsert, being careful not to bend

Table of Tightening Torques

Model	Inner Cover		Screen Holder	
	Torque		Torque	
	N·m (ft·lb)	Distance Across Flats mm (in)	N·m (ft·lb)	Distance Across Flats mm (in)
A46S, A65S	250 (185)	46 (1 ³ / ₁₆)	100 (73)	30 (1 ³ / ₁₆)
A46SW	320 (235)	50 (2)	100 (73)	30 (1 ³ / ₁₆)

NOTE: Be sure to coat threads with anti-seize

(1 N·m ≈ 10 kg·cm)

Exploded View

* Asteriskisked parts make up the valve seat unit

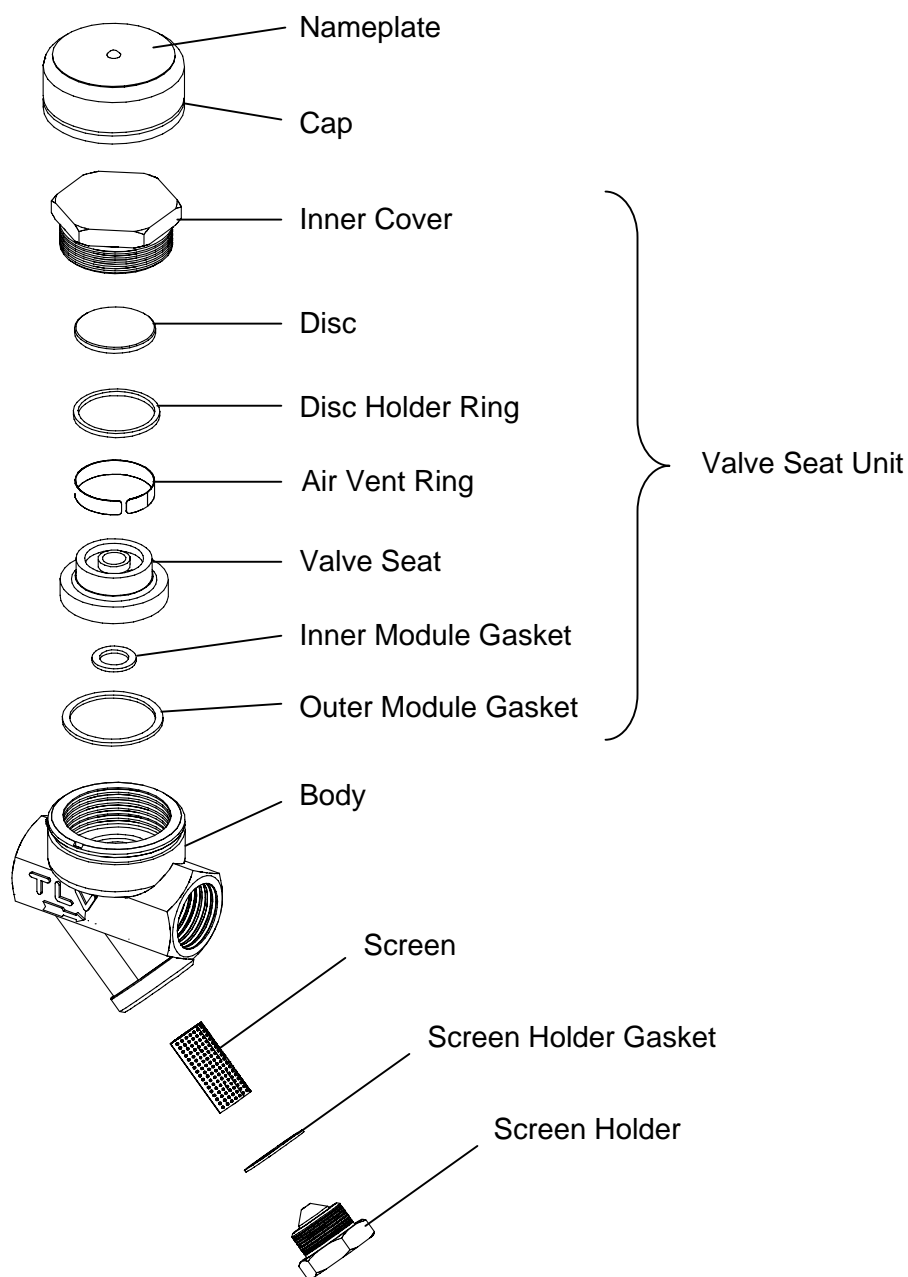

Troubleshooting



When disassembling or removing the product, wait until the internal pressure equals atmospheric pressure and the surface of the product has cooled to room temperature. Disassembling or removing the product when it is hot or under pressure may lead to discharge of fluids, causing burns, other injuries or damage.

When the trap fails to operate properly, use the following table to locate the cause.

Problem	Cause	Remedy
No condensate is discharged or discharge is poor (blocked)	Check the module valve seat, screen and piping to see if they are clogged with rust or scale	Clean parts
	Check to see if the disc is stuck to the module valve seat	Clean parts
	Check to see if air-locking has occurred	Perform a bypass blowdown, or close the trap inlet valve and allow the trap to cool
	Air-locking has occurred due to disc holder ring and or air vent ring wear	Replace with new disc holder ring or air vent ring
	Check to see if steam-locking has occurred	Perform a bypass blowdown, or close the trap inlet valve and allow the trap to cool
	Check to see if the trap operating pressure exceeds the maximum specified pressure, or whether there is insufficient pressure differential between the trap inlet and outlet	Compare specifications and actual operating conditions
Steam is discharged or leaks from the outlet (blowing) (steam leakage)	Check to see if there is rust or scale on the disc or on the module valve seat	Clean parts
	Check the disc and the module valve seat for damage or wear	Replace with new disc or module valve seat
	Check for improper installation	Correct the installation
	Check for trap vibration	Lengthen inlet piping and fasten securely
	Check to see if the trap operating pressure is less than the minimum specified pressure or whether the back pressure exceeds the allowable back pressure	Compare specifications and actual operating conditions
Steam is leaking from a place other than the outlet	Check for gasket deterioration or damage	Replace with new gasket(s)
	Check to make sure that the proper tightening torques were used	Tighten to the proper torque

NOTE: When replacing parts with new, use the parts list for reference, and replace with parts from the Maintenance Kit and/or Repair Kit. Please note that replacement parts are only available as part of a replacement parts kit.

Product Warranty

1. Warranty Period

One year following product delivery.

2. Warranty Coverage

TLV CO., LTD. warrants this product to the original purchaser to be free from defective materials and workmanship. Under this warranty, the product will be repaired or replaced at our option, without charge for parts or labor.

3. This product warranty will not apply to cosmetic defects, nor to any product whose exterior has been damaged or defaced; nor does it apply in the following cases:

- 1) Malfunctions due to improper installation, use, handling, etc., by other than TLV CO., LTD. authorized service representatives.
- 2) Malfunctions due to dirt, scale, rust, etc.
- 3) Malfunctions due to improper disassembly and reassembly, or inadequate inspection and maintenance by other than TLV CO., LTD. authorized service representatives.
- 4) Malfunctions due to disasters or forces of nature.
- 5) Accidents or malfunctions due to any other cause beyond the control of TLV CO., LTD.

4. Under no circumstances will TLV CO., LTD. be liable for consequential economic loss damage or consequential damage to property.

* * * * *

For Service or Technical Assistance:

Contact your **TLV** representative or your regional **TLV** office.

Manufacturer

TLV CO., LTD.
881 Nagasuna, Noguchi
Kakogawa, Hyogo 675-8511 JAPAN
Tel: 81-(0)79 - 427 - 1800

Options



When operating the blowdown valve, stand to the side well clear of the outlet to avoid contact with internal fluids that will be discharged. Failure to do so may result in burns or other injury.



Do not use excessive force when opening the blowdown valve. Such force may break the pin equipped as a valve stopper pin, causing a blowout from internal pressure resulting in burns or other injury.

With Blowdown Valve (TLV BD2)

Configuration

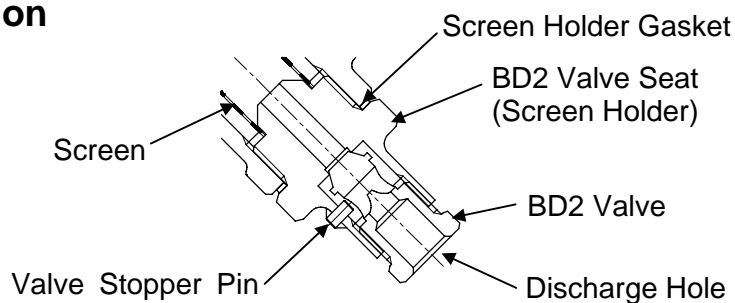

TLV Blowdown Valve: BD2

The BD2 Blowdown Valve, installed in the screen area of the body, uses the trap's internal pressure to blow any condensate, steam, dirt or scale accumulated around the screen area out to atmosphere.

BD2 Blowdown Valve Operation



Install properly and DO NOT use this product outside the recommended operating pressure, temperature and other specification ranges. Improper use may result in such hazards as damage to the product or malfunctions which may lead to serious accidents. Local regulations may restrict the use of this product to below the conditions quoted.



Take measures to prevent people from coming into direct contact with product outlets. Failure to do so may result in burns or other injury from the discharge of fluids.



Do not use excessive force when connecting threaded pipes to the product. Over-tightening may cause breakage leading to fluid discharge, which may cause burns or other injury.

1. The BD2 valve is in the closed position when the BD2 is shipped from the factory. Before attempting to operate the BD2, reconfirm that the BD2 valve is still in the closed position. Locate the blow outlet and, during operation, stand to the side and well clear of it, as the jet of condensate or steam could cause burns.
2. Remain in the area the entire time the BD2 valve is in the open position. Before opening the BD2 valve, grip the BD2 valve seat with a wrench and hold firmly in place so that it will not rotate when the BD2 valve is loosened. Grip the BD2 valve with another wrench and slowly loosen. Condensate and steam will discharge from the blow outlet in a jet stream. Be careful not to loosen the BD2 valve so far that it becomes removed from the BD2 valve seat. (If the grooved pin becomes damaged, large quantities of steam will be discharged in a jet stream.)
3. Close the BD2 valve until the flow of fluid completely stops. If the flow of fluid does not stop, re-open the valve (as in step "2") to blow out any scale or dirt that may be caught in the valve. Re-tighten the valve until the flow of fluid stops completely.

Tightening Torques and Distance Across Flats				
Part	Torque		Distance Across Flats	
	N·m	(lbf·ft)	mm	(in)
BD2 Valve	30	(22)	17	(²¹ / ₃₂)

(1 N·m ≈ 10 kg·cm)

Note: Avoid the use of excessive tightening torques, as threaded parts may become damaged.