

Multicontroller

SC-F70

Auto-Tuning PID and Heating, Cooling PID Operating Instructions

172-65281M-00

Table of Contents

Preface	4
For Your Safety	4
Checking the Model Code and Accessories	5
1. Introduction and Installation	6
1.1 How to Use This Book	6
1.2 Setting Feature Jumpers	7
1.3 Attaching to the Panel	9
1.4 Wiring Procedure	11
2. Using the Panel	17
2.1 Names and Functions on the Panel	17
2.2 Guides for Using Keys	19
3. Operation	28
3.1 Setting Up the Basic Parameters	28
3.2 Test Operation (LOC/MAN Mode)	37
3.3 Automatic Operation (LOC/AUT Mode)	43
3.4 Area Switching Automatic Operation (LOC/AUT Mode)	46
3.5 Compensation for Control Responsiveness	51
3.6 PID Constants Fine-Tuning Method	52
3.7 PID Constants Setting and Control Operation	53
4. Remote Operation (REM/AUT Mode)	55
4.1 Remote Analog Setting Operation	55
4.2 Remote Area Switching Operation	58
5. Using Other Functions	62
5.1 Using Alarms	62
5.2 Using the Transmission Output	65
5.3 Using the Communications Function	66
5.4 Using Other Convenient Features	66
5.5 What Happens When Power Is Lost	67
6. Summary of Parameter Groups and Areas	68
6.1 Parameters	68
6.2 Areas	81
7. Troubleshooting	84
7.1 Problem Area	84
7.2 Error Displayable Controller Problems	89
7.3 No Error-Displayable Problems	92
7.4 Actuator Control Problems	95
7.5 Sensor Problems	96
7.6 Area Switching External Contact Problems	99
7.7 External Analog Input Problems	100
7.8 Communication Problems	101

7.9 Other Problems	102
8. PID Constants Manual Tuning Method	103
8.1 Step Response Method	103
8.2 Ultimate Sensitivity Method	105
9. Specifications	106
9.1 Display Functions	106
9.2 Measurement Input	106
9.3 Settings	107
9.4 Control Operation	108
9.5 Control Output	108
9.6 Alarm Output	110
9.7 Transmission Output	111
9.8 External Contact Input	111
9.9 Communication Output	112
9.10 Self-Diagnostic Function	114
9.11 General Specifications	115
9.12 Environmental Conditions (Normal Operation)	115
9.13 Shipping and Storage Conditions	116
10. Product Warranty	117

Preface

Thank you for choosing the **TLV SC-F70** Multicontroller, a multipurpose, multifunction, easy-to-use controller for your steam system.

About This Book

The multicontroller (hereafter, called the *controller*) can be used to control various things, as listed here:

- Auto-tuning PID operation and heating, cooling PID operation (These operating instructions)
- Pressure control
- Temperature control

We have prepared a book containing operating instructions for each type of use.

It is important that you use the correct book for your controller.

When the controller was shipped from our factory, the correct book should have been packed according to your order, but please recheck it now. This book contains instructions for using the controller for Auto-tuning PID operation and heating, cooling PID operation.

This book provides, for both inexperienced users and experts, information for installing and operating your controller, and troubleshooting problems. It also contains product specifications and warranties.

For Your Safety

• Safety mark

Every safety notice in this book is shown with a safety mark (). Please read these notices carefully before proceeding.

Danger: Protecting electrical terminals

This product is designed and manufactured to be used mounted on an instrument panel and the electrical terminals on the back side of the controller are left exposed.

Therefore, the user must install a protective cover over the terminals to prevent electrical shock to the user or damage to the multicontroller.

This book will be updated from time to time according to improvements made to the product. But if you find a discrepancy between the descriptions in this book and actual operation, and need help, contact TLV.

Checking the Model Code and Accessories

Check to make sure you received the correct model of controller and features, and that the necessary accessories were enclosed.

1. Model code

The model code label is attached to the side of the controller case. The label should read:

SC-F70- $\frac{*}{a}$ $\frac{*}{b}$ $\frac{*}{c}$

a is one of the following numbers:

- 0: Auto-tuning PID operation
- 1: Heating, cooling PID operation

b shows the type of external contact:

- N: No external contact feature
- A: External analog input
- D: External area switching contact input

c shows the communication type:

- N: No communication feature
- 1: RS-232C
- 4: RS-422A
- 5: RS-485

2. Accessories

The controller package contains:

1. The controller
2. The *Operating Instructions* (this book)
3. A mounting hardware set (2 brackets)
4. The *Operating Instructions for Communications* (If the communication feature is specified)

If the model code differs from your order, or accessories are missing or damaged, please contact TLV immediately.

1. Introduction and Installation

This chapter describes how the controller should be set up, mounted, and cabled.

1.1 How to Use This Book

This chart shows an overview of installation flow, with page numbers for reference.

Checking model code and accessories	• Confirms that you received the correct model and accessories (see page 5).
Setting feature jumpers	• Customizes the controller with jumpers on a controller board (see page 7).
Attaching to the panel	• Mounts the controller on a panel (see page 9).
Wiring	• Connects the cable to a control valve, sensor, and other connectors (see page 11).
Setting up basic parameters	• Turns power on and sets up the basic parameters (see page 28).
Running in test operation	• Runs the controller in manual mode (see page 37).
Running in automatic mode	• Runs using areas and parameters in local, automatic mode (see page 43).
Running in remote mode	• Runs using external contacts in remote, automatic mode (see page 55).
Using other functions	• Runs using alarms, transmission output, or communications (see page 62).
Troubleshooting	• Resolves problems you may encounter (see page 84).

1.2 Setting Feature Jumpers

The following feature jumpers can be set to customize your controller.

- To select measurement input type
- To select analog input (used only with the analog input feature).

These jumpers are set at the factory to your order specifications. If BOTH of the following conditions are met, there is NO need to check the jumper setting. You can go to "1.3 Attaching to the Panel" directly.

1. The sensor to be used is a pressure transmitter MBS33M (from Danfoss A/S), KH15 (from Nagano Instrument Corp.), or a temperature sensor TR1 obtained from TLV.
2. Remote analog setting operation is not used.



Warning:

Do not try to use the controller without setting the jumpers correctly according to your mode of operation. If you do, an unexpected malfunction may arise.

Use these steps to set the jumpers

1. Make sure the controller is turned off.
2. Remove the controller body from its case (see Figure 1).
 1. While pushing the stopper tab **1** upward,
 2. Pull the body by the frame of the display panel **2**.
3. To identify the two groups of jumpers, see Figure 2.

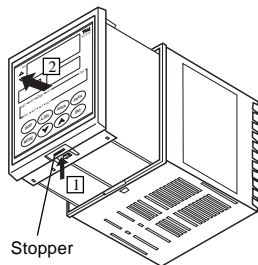

[Figure 1]



Warning:

To prevent damage, do NOT touch any metal parts on the boards when you do the next step.

4. Using tweezers, remove and insert the jumpers at the appropriate positions. Refer to Figure 2 for the jumper positions to select Measurement Input and Analog Input.

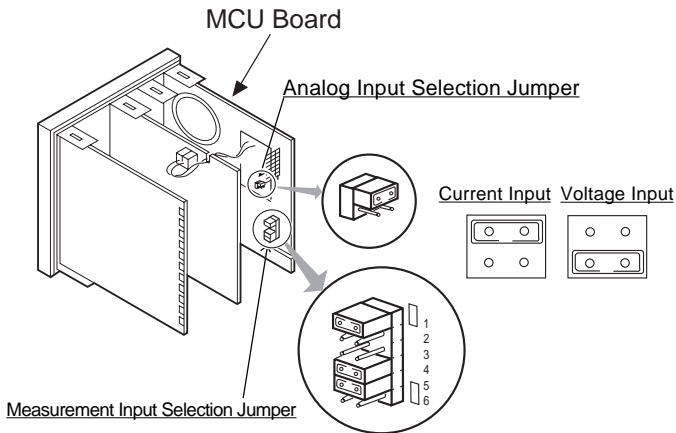

Current Input

RTD
Thermocouple

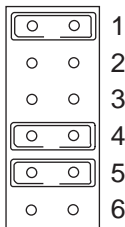

Voltage Input
(High)

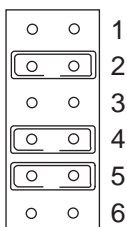

Voltage Input (Low)

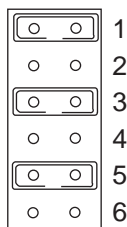

[Figure 2. Jumper Setting Guide]

- Restore the body into the case, and make sure it latches firmly at the stopper.

1.3 Attaching to the Panel

⚠ Warning: Do not install the multicontroller in the following conditions:

- Where the ambient temperature is higher than 50°C (122°F) or lower than 0°C (32°F).
- Where the relative humidity is lower than 20% or higher than 80%.
- Where corrosive gas is generated.
- Where strong vibrations and the potential for shock exist.
- Where there is flooding or splashing of oil.
- Where there is excessive dust.
- Where there is any inductive disturbance which adversely affects electrical instruments.

Controller Dimensions and Panel Cut Sizes

These figures show the sizes of the controller and the panel cut needed to fit the controller in millimeters (inches).

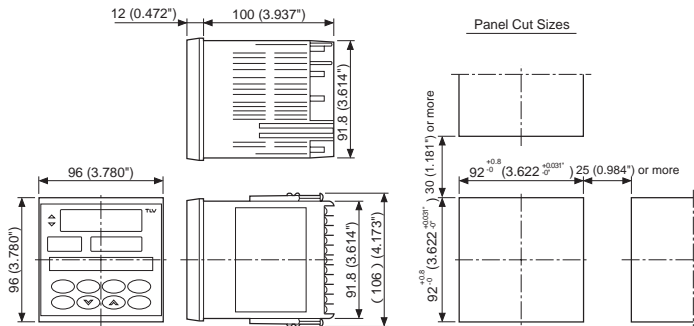

Procedure for Attaching to the Panel

1. Referring to the previous figures, cut as many square holes in the panel as are needed for the number of controllers to be installed.

Note: The panel thickness must be between 1 to 10 mm (0.04 to 0.4 inch).

2. Mount the controller into the cut from the front of the panel.
3. Insert one of the brackets shipped with the controller into the slot on the top of the controller (see Figure 1).
4. With a Phillips head screwdriver, tighten the screw from the rear of the bracket (see Figure 2).



When a gap is no longer seen between the panel and the controller tighten one more full turn.

Be careful not to tighten too much, because the controller case becomes distorted when overly tightened.

5. Repeat steps 3 and 4 to insert the other bracket on the bottom of the controller and fasten it in place.

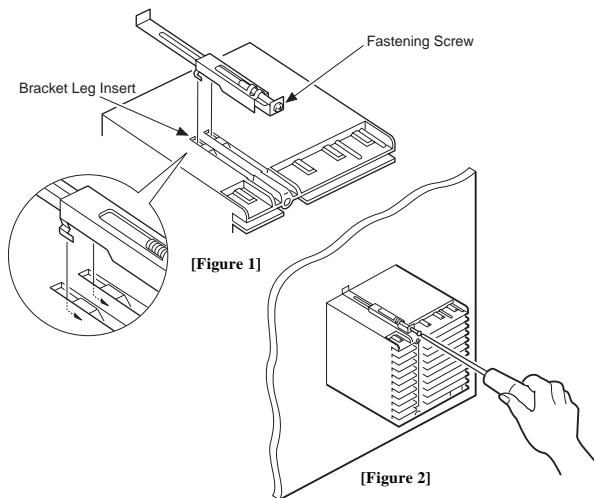

1.4 Wiring Procedure

Refer to the following "Wiring Precautions" and to "Terminal Configuration" on page 14, to install the cabling.

⚠ Warning

Read the following precautions for selecting and wiring cables. Improper wiring may cause unexpected, intermittent, or difficult-to-analyze problems.

Wiring Precautions

1. For input and output signal wire (measurement input, analog input, transmission output, and control output to the valve):
 - 1.) Lay input and output cables as far as possible from power lines to the controller or other equipment to avoid noise interference, especially from inverter power lines as they are liable to produce interference requiring countermeasures be taken on the inverter side to suppress noise emission.
 - 2.) Use an electrically isolated receiver when transmission outputs are utilized. If the receiver is not an isolated type, the connection must be made using an isolation amplifier.
 - 3.) Use shielded cables for input and output signal cables.
 - 4.) When using shielded cables, to prevent noise from being generated due to floating capacity and the difference in grounding potential between the cable core and shield, ground the shield as follows:
 - a. If the signal source is grounded, ground only the side closest to the signal source.

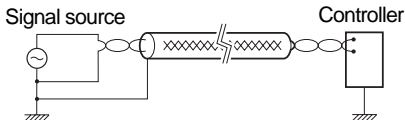

- a. If the signal source is not grounded, ground the controller side.

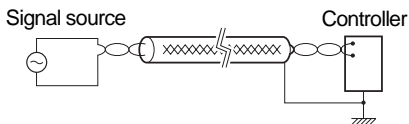

2. For power lines

Wiring of the controller power source should be done so it will not be affected by noise from power sources. When a source of noise is nearby and the controller is affected by the noise, use a noise filter.

- 1.) Certain types of noise filter may not perform properly. Consider the line voltage, filter frequency characteristics, and other things before selecting a filter.

We recommend using the **ZCB2203-11S** filter, manufactured by **TDK**.

- 2.) Be sure to mount noise filters on grounded panels, and use the shortest cable possible between the noise filter output and controller power terminal. A filter mounted on a longer cable may be ineffective.
- 3.) When power cables and other cables for the controller are adversely affected by noise, twist the power supply cables together. The smaller the pitch, the greater effectiveness against noise.
- 4.) Do not install fuses, switches, or other such items on the cables between the noise filter output and the controller power terminals, because this may adversely affect filter performance.

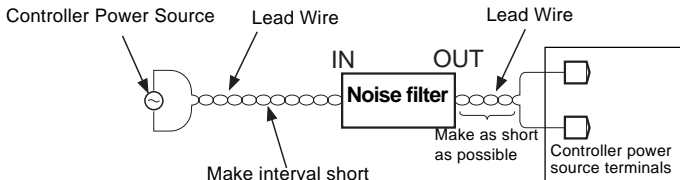

3. For grounding

- 1.) Use only power cables that conform to local electrical codes. To ground the controller, use cables with a nominal cross-sectional area of 2.0 mm² (0.031 sq.in.) or more, use the same contact point as the contact ground on the actuator, and ground in the shortest possible distance.
- 2.) It will take about 3 seconds for the controller to prepare for contact output when the power is turned on. When using the controller to send a signal to an external interlock circuit or other circuits, add a delay relay.

4. Other Precautions

- 1) Use M3.5 crimp terminals with insulating sleeves.
- 2) Use a time-lag fuse rated for 250 V, 1 A, if you install an external fuse.
- 3) Refer to this wire specification table when selecting cables.

Recommended Wire Specifications

	Wire Specifications		
	Diameter (mm ²)	AWG*	Type
Power line	1.25 or larger	16 or larger	Cabtyre
Grounding wire	2.00 or larger	14 or larger	Cabtyre
In, out signal	0.75 or larger	18 or larger	2-wire or 3-wire shielded

* American Wire Gage



Warning

Do not turn on power supply to the value with which this controller will be used until instructed to do so in section 3.2 "Test Operation".

Terminal Configuration and Wiring

The next diagram shows a minimum configuration and its wiring. This is the simplest configuration in which basic operations can be performed; using the pressure transmitter MBS33M (from Danfoss A/S) or the temperature sensor TR1 and the control valve CV10 or CV16 shipped with the controller from TLV. (Other possible connections are shown on page 16.)

a. An example for auto-tuning PID operation

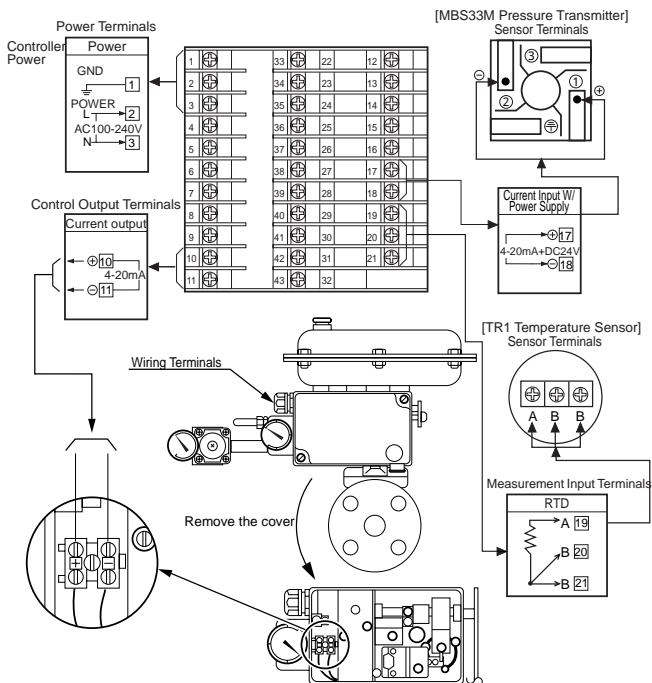

[Figure 1. Minimum Configuration]

⚠ Warning

1. Do not use unused terminals as relay terminals.
2. There are temperature compensating elements at the bottom of the terminal marked 21. Be careful not to damage these elements when wiring cables.

b. An example for heating, cooling PID operation

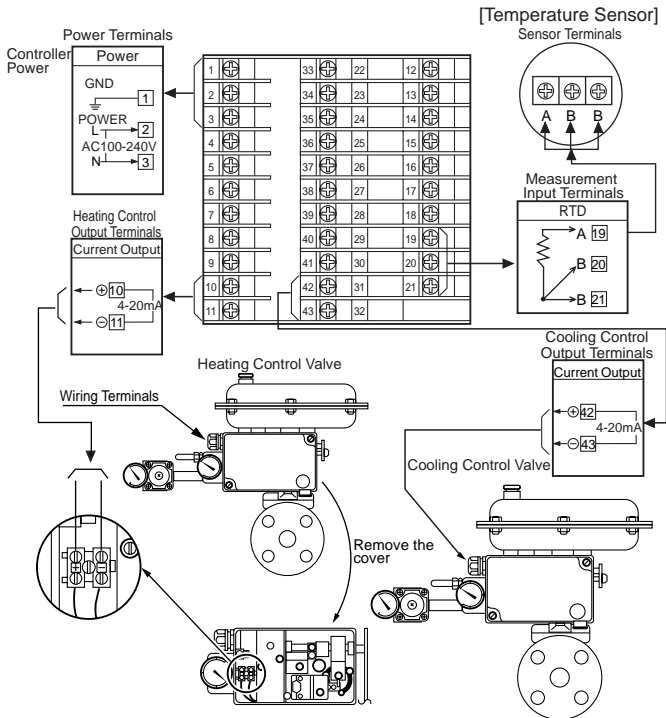

[Figure 2. Minimum Configuration]

This figure shows all possible connections.

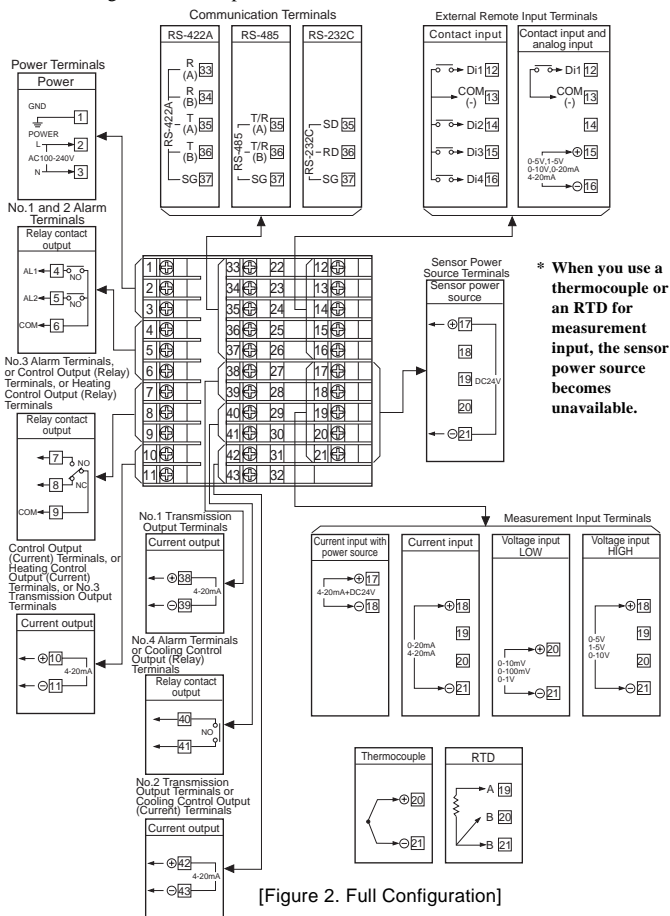

2. Using the Panel

To run the controller, data must be entered into some areas and parameters in advance. This chapter shows how to use the keys and how to read messages displayed on the LEDs, and explains how to enter the necessary data.

2.1 Names and Functions on the Panel

□ : LED Display
○ : Keys

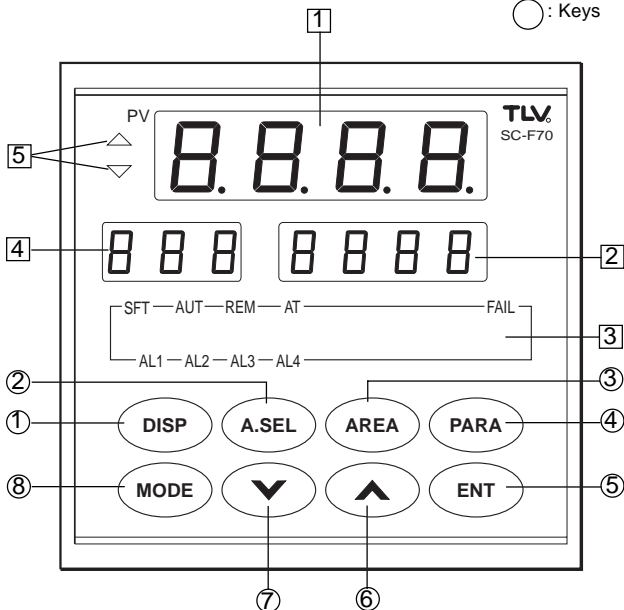

LED Display

No.	Name	Functions
1	Measured Value (PV)	<ul style="list-style-type: none"> Shows measured values Shows symbols while setting areas or parameters
2	Set Value (SV)	<ul style="list-style-type: none"> Shows set values Shows changed values while setting areas or parameters
3	Indicator Lamp SFT AUT REM AT FAIL AL1 AL2 AL3 AL4	<ul style="list-style-type: none"> Shows the status of the controller On during control when set values SoFT start through time On during AUTo mode On during REMote mode Blinks during auto-tuning On when a CPU FAILure is detected On when an ALarm condition exists
4	Symbol Display	<ul style="list-style-type: none"> Shows symbol code to indicate what is shown on Set Value display
5	Deviation Display	<ul style="list-style-type: none"> Shows status of deviation between set value (SV) and measured value (PV) On when PV is greater than SV On when PV is less than SV

Keys

No.	Name	Functions
①	Display key (DISP)	<ul style="list-style-type: none"> Calls up and scrolls through operational displays
②	Area Select key (A.SEL)	<ul style="list-style-type: none"> Selects an area number
③	Area key (AREA)	<ul style="list-style-type: none"> Refers to or sets an area group
④	Parameter key (PARA)	<ul style="list-style-type: none"> Refers to or sets a parameter group
⑤	Enter key (ENT)	<ul style="list-style-type: none"> Registers the new setting
⑥	Up key (Λ)	<ul style="list-style-type: none"> Increments a setting value
⑦	Down key (V)	<ul style="list-style-type: none"> Decrements a setting value
⑧	Mode key (MODE)	<ul style="list-style-type: none"> Changes operation modes

2.2 Guide for Using keys

This section explains how to use keys to accomplish your specific tasks:

- 1) If you want to know the controller's target set value, soft start time, or valve control output during normal controller operation, or you want to end any of the following 2), 3), 4), or 5) key operations:

Go to "**DISP** Key Operation Flow" on page 20.

- 2) If you want to select an area number for an operation:

Go to "**A.SEL** Key Operation Flow" on page 22.

- 3) If you want to know or change the values set in a specific area:

Go to "**AREA** Key Operation Flow" on page 23.

- 4) If you want to know or change the values set in a specific parameter:

Go to "**PARA** Key Operation Flow" on page 24.

- 5) If you want to know or change the mode of operation:

Go to "**MODE** Key Operation Flow" on page 25.

◆ (DISP) Key Operation Flow

At any time, pressing the (DISP) key displays the following controller values:

a. Auto-tuning PID operation

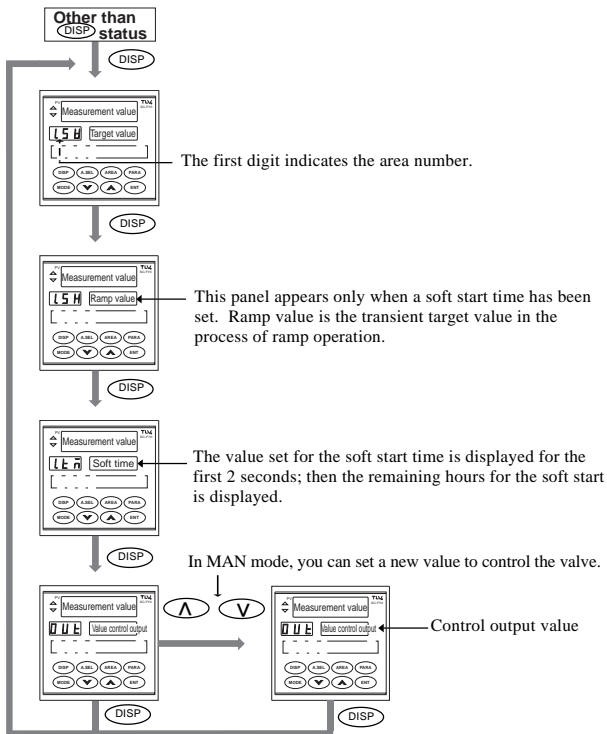

Note: When you press the (DISP) key the first time in MAN mode, the current control value is displayed.

b. Heating, cooling PID operation

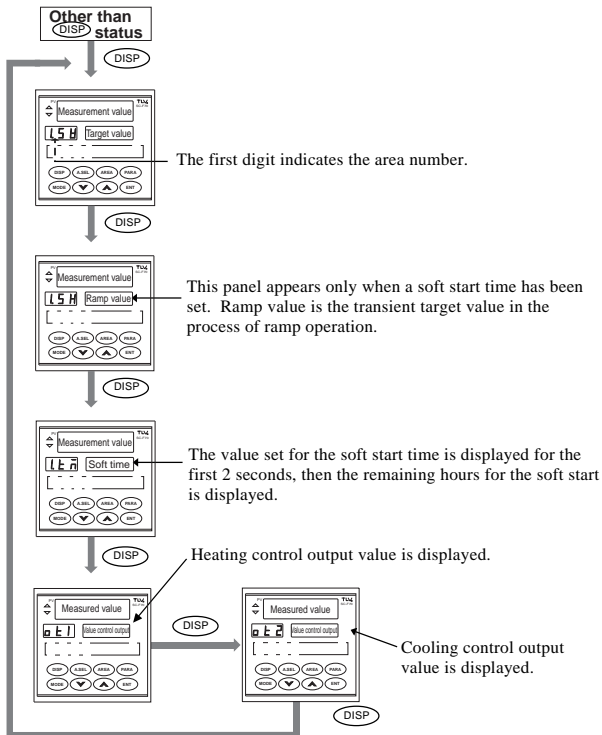

Note 1: In MAN mode, the control output value at the switching time to MAN mode is maintained. You cannot change the control output value manually using the Δ , ∇ keys.

However, if you have set a preset value for the control output at the switching time to MAN mode in PG 08 (see page 78), the preset value is maintained only for the heating control output, and the cooling control output value will go to zero.

Note 2: In MAN mode, when you press the DISP key from another operating environment, the heating control output value (ot1) is displayed first.

◆ (A.SEL) Key Operation Flow

The controller provides eight memory areas in which target values and other control values are stored. The storage location is called an *area*. Each push of the (A.SEL) key increases the area number sequentially, and pressing the (ENT) key selects the displayed area number for the operation.

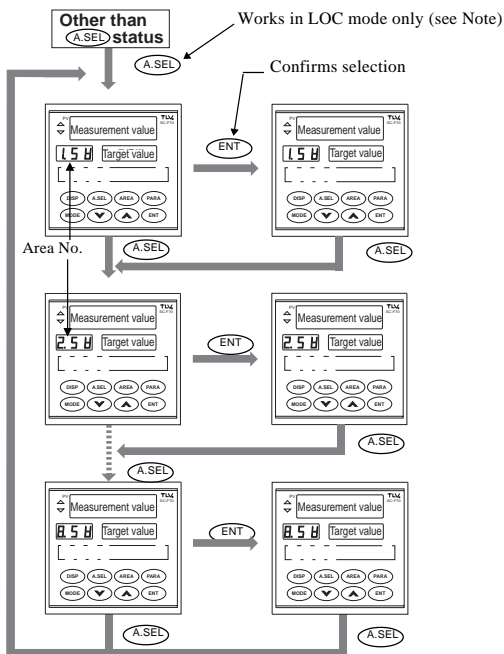

Note: When in REM mode, pressing the (A.SEL) key is invalid and an E22 error code appears. Change to LOC mode first, then try again.

◆ (AREA) Key Operation Flow

Each area contains 14 items (Note 5 and Note 6); SV, tM, A1, A2, A3, A4, P, I, d, oH, oL, Mr, db and Cr. By pressing the (AREA) key, you can display the contents of each item, and in combination with the (V) (Λ) and (ENT) keys, you can change these values.

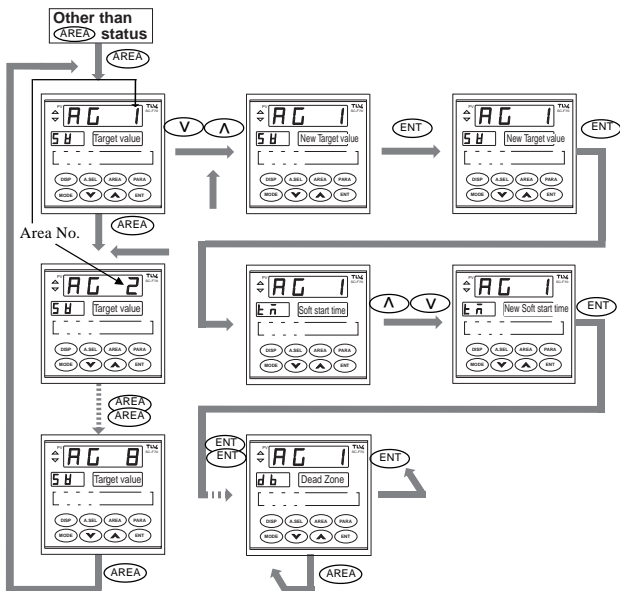

Notes:

1. Each push of the (AREA) key advances the area group number displayed.
2. Each push of the (ENT) key advances the area item number displayed.
3. When a new value is entered by (V) (Λ) keys, the decimal point of the target value starts blinking. When you press the (ENT) key to register the new value, the blinking stops.
4. When you press the (AREA) key the first time, the area number currently in use is displayed.
5. In heating, cooling PID operation, each area contains 18 items; SV, tM, A1, A2, A3, A4, P, I, d, Pc, oH, oL, oHc, Mr, Mrc, db, dbc, and Cr.
6. See page 81 for details on each item.

◆ (PARA) Key Operation Flow

The (PARA) key displays the content of any item for any one of 12 parameter groups. With the (Λ) (V) keys and the (ENT) key, you can change the value of the parameter.

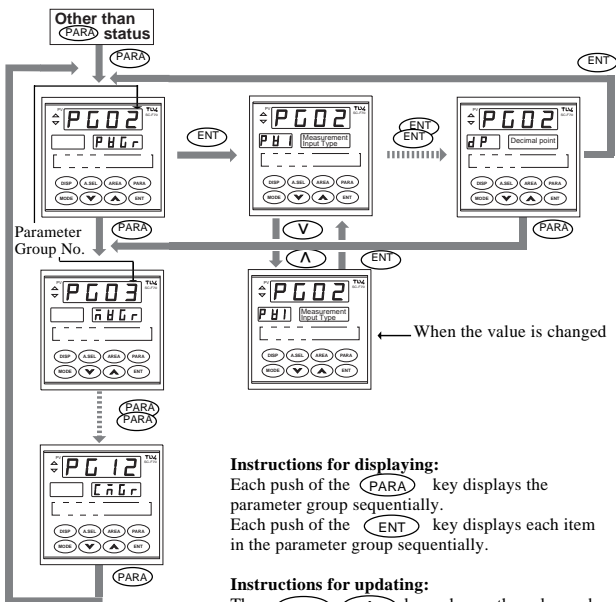

Instructions for displaying:

Each push of the (PARA) key displays the parameter group sequentially.

Each push of the (ENT) key displays each item in the parameter group sequentially.

Instructions for updating:

The (V) (Λ) keys change the value and (ENT) key registers the new value.

◆ (MODE) Key Operation Flow

By using the (MODE) key, you can switch between Local and Remote and Manual and Auto modes, or you can start or stop Auto-tuning. The AUT, REM, or AT lamp glows to indicate the controller is in Auto, Remote, or Auto-tuning mode, respectively. When these lamps are out (not glowing), the system is in Manual or Local mode. When you press (MODE), the current mode is shown in the symbol LED (on the left), and the mode you can select is shown blinking in the set-value LED (on the right).

Pressing (ENT) makes the new mode effective immediately, and the panel displays the new state automatically.

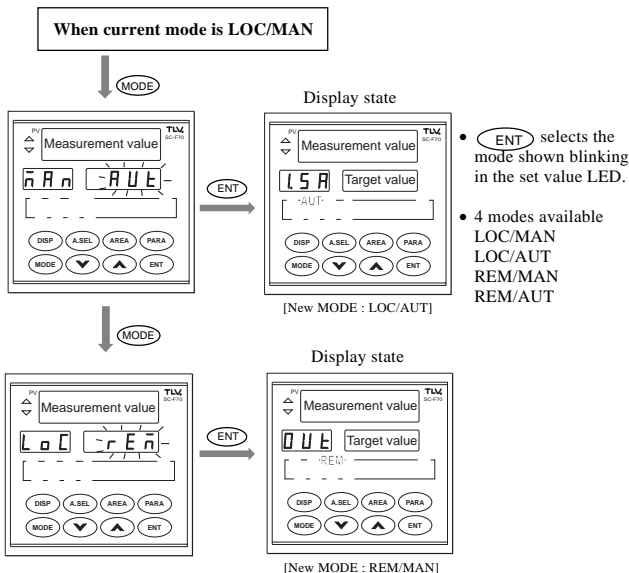

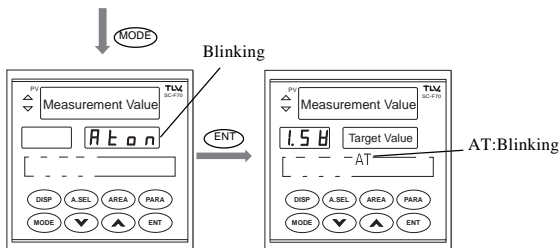

! When you press the **ENT** key while Aton is blinking, Auto-tuning starts. Then the AT lamp blinks to indicate that Auto-tuning is in operation.

To use Auto-tuning, see "Setting the PID constants for Auto-tuning Operation" on page 40.

*During the Auto-tuning process, MAN to AUT or LOC to REM switching is prohibited; therefore, their selection displays do not appear.

*In heating, cooling PID operation, you cannot use Auto-tuning; therefore, Aton is not displayed.

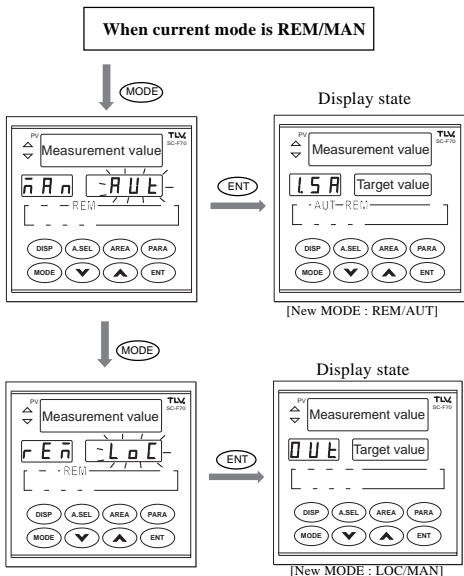

***In REM mode, the Auto-tuning operation is prohibited; therefore, Aton does not appear.**

3. Operation

This chapter describes how to run the controller in various situations, from simple operations to more complex ones.

- Setting up the basic parameters
- Test operation (in local/manual mode)
- Automatic operation (in local/automatic mode)
- More convenient automatic operation (using area switching)

⚠ Warning:

Do not turn on power or the air supply to the actuator (for control valves, etc) until you are instructed to do so.

- ⚠ When the controlled unit is a control valve, keep the inlet shutoff valve closed until you are instructed to open it.**

If you encounter any problems or the controller does not work as expected while completing these steps, go to "7. Troubleshooting" on page 84 to analyze the problems.

3.1 Setting Up the Basic Parameters

Before using the controller, you must set up the following two parameters (basic parameters):

1. Measurement input (PG02)
2. Control output (PG03)

◆ How to Set Up Basic Parameters

This step-by-step procedure describes how to set up the basic parameters .

- ① Turn on the controller.

⚠ Do not apply power or the air supply to the actuator (for control valves, etc.) at this point.

- ② Set the controller in LOC mode by referring to " **MODE** Key Operation Flow" on page 25. If the REM indicator lamp is off, it is already in LOC mode, so you can omit this step.

- ③ Press **PARA**.

The display changes to:
 PV: Group number (PG02)
 SV: Group name (PVGr)
 Symbol: Blank

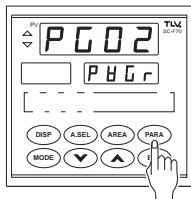

- ④ Press **ENT** once.

The display changes to:
 PV: Group number (PG02)
 SV: Content value of the item No.1,
 coefficient factor (0)
 Symbol: Symbol for item No.1 (PV1)

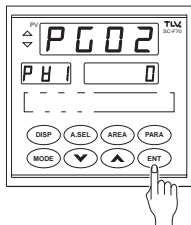

- ⑤ Change the coefficient value of item PV1 by **Λ** or **V**.

The value for each item must be determined as described on page 32.

- * When you press the **Λ** or **V** key, the decimal point starts to blink to indicate it is being updated.
- * If the set value does not contain a decimal fraction, the decimal point appears next to the last digit.
- * Continuous pressure on the key will make the value change rapidly.

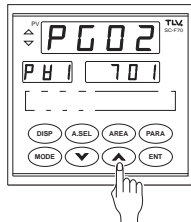

Note: If the **Λ** or **V** key does not work, make sure the mode is MAN.
 Return to step ② to set the mode correctly.

- ⑥ Press **ENT** to register the new value.
- * The decimal point will stop blinking.
 - * If the value contains no decimal fraction, the decimal point next to the last digit will disappear.

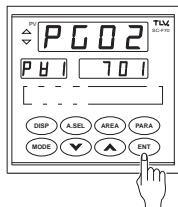

- ⑦ Press **ENT** to go to the next item.
- * The next item (coefficient PVL) will appear.

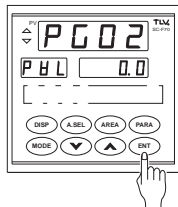

- ⑧ Repeat steps ④ to ⑦ to address all items, 1 to 8 (on page 33), of the parameter PG02.
- * If no change is necessary, press **ENT** only to scroll to the next item.
 - * Pressing **ENT** advances the item number sequentially.

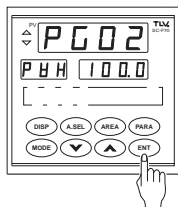

- ⑨ To advance to the parameter group (PG03), press **PARA** once.
- * If **PARA** was pressed twice and PG04 is shown, press **PARA** repeatedly until PG03 is shown again.
 - * Refer to PG03 on page 35 to determine the value for each item.

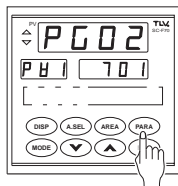

- * By referring to steps ④ to ⑦, set all the items for PG03 in the same manner.
- ⑩ When item number 8 (time proportional period for cooling) of PG03 is entered, basic parameter setup is complete.
- Press **DISP** to exit set-up mode.

◆ **Basic Parameter Groups (PG02 and PG03)**

The controller needs the parameters to be set correctly to control the system. Parameter groups 2 and 3 are mandatory for running the controller, while other groups are optional.

This section describes what values should be set for every item in PG02 and PG03.

1. PG02/PVGr (measurement input)

No.	Symbol	Name	Description	Range	Factory setting
1	\overline{PVI}	Measurement input type	To set this value, see the table of Measurement Input Types and Ranges shown on the next page.	0 to 701	Depends on order specifications.
2	\overline{PVL}	Lower limit of measurement input range	These values are used to set a range for the sensor used. * When the PVI range is set between 0 to 511, these parameters do not appear.	-199.9 to 999.9 (See Note 1) 1. PVL < PVH 2. For decimal position, see item No. 6.	Depends on order specifications.
3	\overline{PVH}	Upper limit of measurement input range			
4	\overline{PVF}	Measurement input filter	Applies a first-order lag to reduce noise from measurement input.	0 to 100 sec.	0
5	\overline{PVb}	Measurement input bias	Applies bias to measurement input for sensor accuracy correction.	± 5 % of measurement span [Measurement unit] (See Note 2)	0.00
6	\overline{PVR}	Extraction of the square root of measurement input	Specifies if an extraction function of the square root is required. * This parameter is displayed only when the measurement type PVI is set to 600-701.	0: Not required 1: Required	0
7	\overline{PVC}	Low-cut of measurement input	Cuts low values and measurements that may amplify the result of the extraction of the square root. * This parameter is displayed only when PVR=1.	0.00 ~ 25.00%	0.00
8	\overline{dp}	Decimal position	Designates the decimal position for measurement input by the number of digits after the point. (See Note 3)	0 - 3	Depends on order specifications.

Note 1: Use the same unit system as the measurement unit of the control target.







Note 2: Use the same unit system as the measurement unit which is used for the upper limit and the lower limit of the measurement input range. When the measurement input type is 0 ~ 511, use the corresponding unit of °C or °F.

Note 3: When the decimal position is changed, set the upper limit and the lower limit of the measurement input range, and all items set with the measurement unit.

Measurement Input Types and Ranges

Group	Sensor	Input Range	Setting	Group	Sensor	Input Range	Setting	Group	Sensor	Input Range	Setting	
Thermo-couple	K	0.0~400.0°C	0	Thermo-couple	K	0.0~800.0°F	200	Voltage Input	Low	0~10mV	600	
		0.0~800.0°C	1			0~100mV	601					
	J	0.0~400.0°C	10		J	0.0~700.0°F	210			0~1V	602	
		0.0~800.0°C	11			E	0.0~999.9°F			220	0~5V	610
	T	0.0~400.0°C	30		T		0.0~700.0°F			230	High	1~5V
	U	0.0~600.0°C	40		U	0.0~999.9°F	240			0~10V		612
L	0.0~400.0°C	50	L	0.0~700.0°F	250	Current Input	0~20mA	700				
RTD	JPt	0.0~300.0°C	400	JPt	0.0~600.0°F		500	4~20mA	701			
	100	0.0~500.0°C	401	100	0.0~900.0°F	501	/					
	Pt	0.0~300.0°C	410	Pt	0.0~600.0°F	510						
	100	0.0~600.0°C	411	100	0.0~999.9°F	511						

2. PG03/MVGr (Control output)

No.	Symbol	Name	Description	Range	Factory setting
1		Control output type (see Note 1)	Specifies output type for the control output and for the cooling control output. * otc is displayed in the heating, cooling PID operation.	0: Current output 1: Relay output	0
2		Control output type for cooling			1
3		Control output forward or reverse selection	Used to select the type of control output (forward or reverse). * Displayed in the auto-tuning PID operation. * In the heating, cooling PID operation, the movement is always reverse for heating, and always forward for cooling.	0: Reverse 1: Forward	0
4		Hysteresis (see Note 1)	Sets the hysteresis for the ON-OFF operation.	0 ~10% of measurement span	0.1% of measurement span
5		Hysteresis for cooling	* HSc is displayed in the heating, cooling PID operation.	[measurement unit]	
6		Output change rate limiter	Imposes restrictions on the amount of change per unit of time when control output values are changed. * The change rate limiter is OFF when the value is set to 0.0.	0.0 ~100.0 %/second	0.0

No.	Symbol	Name	Description	Range	Factory setting
7	\overline{CY}	Time proportional period (see Note 1)	For current control output: Sets the renewal period for control output.	For current output: 0.0~100seconds * When set to 0, minimum 250 msec.	0
8	\overline{CYc}	Time proportional period for cooling	For relay control output: Sets the proportional period for control output. * CYc is displayed in the heating, cooling PID operation.	For relay output: 1~100seconds	20

Note 1: This parameter is set for the heating in the heating, cooling PID operation.

3.2 Test Operation (LOC/MAN Mode)

This operation verifies the functions of the controller, the actuator (for control valves, etc), and the sensor used in the system.

This section describes an example of the controller operation with the Auto-tuning PID operation in which a general-purpose control valve is used as the actuator (see Note 1).

In the heating, cooling PID operation, the control output value is fixed in MAN mode, and the test operation described here cannot be run.

Therefore, set the PID constants for both heating and cooling (see Note 2) following "8. PID Constants Manual Tuning Method" (page 103), then go to "3.3 Automatic Operation (LOC/AUT Mode)" (page 43).

Note 1: If you use other equipment for the actuator, consider the general-purpose control valve as that equipment, and refer to this description. For details or clarification, contact TLV.

Note 2: The heating, cooling PID operation has no Auto-tuning function, and PID constants must be set manually.

◆ Running the Test Operation

You can run the test operation by following two procedures:

1. Verifying the control valve actions in the MAN mode
2. Setting the PID constants by running auto-tuning

Procedure-1 Verifying the Valve Actions in MAN Mode

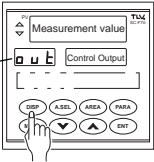
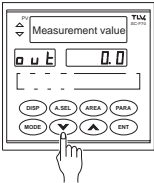
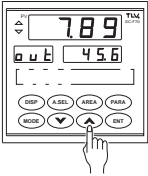
Step	Action											
1	<ul style="list-style-type: none"> Make sure that the AUT and REM lamps are off. If either is on, change the mode to LOC/MAN by referring to "Mode Key Operation Flow" on page 25. 											
2	<ul style="list-style-type: none"> Set the control output to 0 %. <ol style="list-style-type: none"> Press DISP several times until the Symbol Display shows OUT. Press Λ or V key to set the control output value to 0.0 (%). <p>Note: Continuous pressure on Λ or V will change the value rapidly.</p>  											
3	<ul style="list-style-type: none"> Turn on power supply and air supply to the actuator. 											
4	<ol style="list-style-type: none"> Gradually increase and decrease the control output by pressing the Λ or V key. Check that the control valve moves (see Note 1 on next page) as follows: <table border="1" data-bbox="191 1049 740 1188"> <thead> <tr> <th rowspan="2">Control Output</th> <th colspan="2">Control Valve Movement</th> </tr> <tr> <th>Reverse Movement</th> <th>Forward Movement</th> </tr> </thead> <tbody> <tr> <td>Increase</td> <td>open</td> <td>close</td> </tr> <tr> <td>Decrease</td> <td>close</td> <td>open</td> </tr> </tbody> </table> <p>Note: Continuous pressure on Λ or V will move the valve actuator rapidly.</p> 	Control Output	Control Valve Movement		Reverse Movement	Forward Movement	Increase	open	close	Decrease	close	open
Control Output	Control Valve Movement											
	Reverse Movement	Forward Movement										
Increase	open	close										
Decrease	close	open										

Step	Action
5	<ul style="list-style-type: none"> Press V to set the control output below 0.
6	<ul style="list-style-type: none"> Ensure that supplying steam to the equipment is safe. Then gradually open the shutoff valve. Because the control valve is shut (Note 1), check that no steam flows to the secondary side of the control valve.
7	<ul style="list-style-type: none"> By pressing V and Λ, adjust the control output value gradually to reach and stay on a target set value in everyday operation. In the same manner, adjust the control output to obtain several other target set values. Record the control output values and respective target set values for quick reference for later manual operation. You can use the controller for production with this procedure. <div data-bbox="754 398 943 579" data-label="Image"> </div> <p data-bbox="774 589 927 713">In this example, the temperature rises 120°C when the control output is set to 55.5%.</p>
8	<ul style="list-style-type: none"> Decrease the control output to zero percent by pressing V. Make sure that the control valve has been closed (see Note 1). <div data-bbox="754 739 943 965" data-label="Image"> </div>
<ul style="list-style-type: none"> You have completed the verification of valve actions in MAN mode. If you found any problem with the controller, control valve, or sensor during this test procedure, refer to the troubleshooting guides in "7. Troubleshooting" on page 84. 	

Note 1: This description assumes that the control valve actuator moves in a reverse direction. When the actuator moves in a forward direction, the valve behaves in the opposite way.

Procedure-2 Setting the PID Constants with Auto-Tuning

The controller computes the optimal control output value from the difference between the target set value and the measured value for automatic operation. To obtain proper control output, you must provide the controller proper PID constants.

You can use the following two ways to obtain the proper P, I, and D constants.

1. Study the individual characteristics of your control process equipment yourself and generate the proper constants.
2. Run the Auto-tuning operation on the controller. The controller calculates the data based on the characteristics of the process to get the optimal PID constants for the process.



Notice for Running Auto-Tuning



The auto-tuning operation requires temporary On and Off actions during its process. Due to the On-Off actions, the measured value (and the control output) oscillates above and below the target set value. Therefore, if the measured value is higher than the target set value or the oscillation impedes your production, you must either lower the target set value or do a manual PID setting by referring to "PID Constants Manual Tuning Method" on page 103.



In some cases, the optimum PID constants may not be obtainable through the Auto-tuning operation.

Step	Action
1	<ul style="list-style-type: none"> Choose an Area that you are going to set a target value and PID constants for. <p>* Refer to " A.SEL Key Operation Flow" on page 22.</p> 
2	<ul style="list-style-type: none"> Enter the valve control target value into the selected Area. <p>* Refer to " AREA Key Operation Flow" on page 23.</p> <ul style="list-style-type: none"> In the example on the right, 120.0 has been entered as a target set value into Area number 1. 
3	<p>Set the mode to LOC with the MODE Key.</p> <p>* Refer to " MODE Key Operation Flow" on page 25.</p> <p>Notes:</p> <ol style="list-style-type: none"> In REM mode, Auto-tuning cannot be run. Auto-tuning runs in either AUT or MAN. <p>When Auto-tuning ends, the controller resumes as follows.</p> <p>Auto-tuning in AUT:</p> <ul style="list-style-type: none"> Resumes in AUT mode. PID constants are updated for the operation to resume. <p>Auto-tuning in MAN:</p> <ul style="list-style-type: none"> Resumes in MAN mode. PID constants are updated. Operation resumes with the previous valve control output value.

Step	Action
4	<p>• Start Auto-tuning</p> <p>① Press the MODE Key several times until "A t o n" is displayed, blinking.</p> <p>② Press ENT.</p> <ul style="list-style-type: none"> • Auto-tuning starts with the current Area (preselected). • The AT lamp starts blinking to show that Auto-tuning is running. • The AT lamp goes off when Auto-tuning ends. • When Auto-tuning ends normally, the PID constants are updated with optimal constant values.
Note	<p>• To stop Auto-tuning immediately, do the following:</p> <p>① Press the MODE Key. "A t o F" will be blinking.</p> <p>② Press ENT.</p> <ul style="list-style-type: none"> • Auto-tuning stops and returns to Display mode. • The AT lamp goes off. • No update of PID constants takes place.

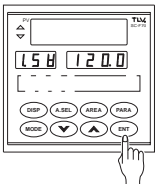
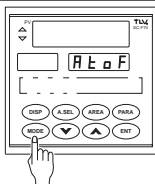
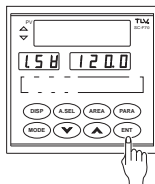
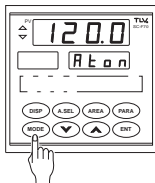
**Notes:**

1. If you try to start Auto-tuning while the ramp operation is in process, Auto-tuning begins after the end of ramp operation.
2. PID constants must be set into each Area you are going to use.
Each PID constant must match the target value of the Area.
3. The Auto-tuning operation sets the PID constants that will perform the best compensation actions against possible external disturbance. If you want to improve the control responsiveness, refer to "3.5 Compensation of Control Responsiveness" on page 51.

3.3 Automatic Operation (LOC/AUT Mode)

In automatic operation, the controller calculates and controls its output according to a new target value. For automatic operation, control target values must be entered by AREA number in the LOC/MAN mode. You can choose various control operation of the actuator when you change the set values of the PID constants. Please refer to "3.7 PID Constants Setting and Control Operation" (page 53), and choose a suitable control operation.

◆ Automatic Operation Procedure

This procedure describes how to set up a target value in an AREA, start the AUT mode, change the target value, and end the operation to turn off the controller.

Step	Action
1	<ul style="list-style-type: none"> • Set up the target set value for item No.1 in the AREA group 1. <ol style="list-style-type: none"> ① Make sure the AUT and REM lamps are off. (If either or both of them are on, set their modes to MAN and LOC, respectively, by referring to "Mode Key Operation Flow" on page 25.) ② Press AREA. The display should look like the example at right. PV: Area group symbol (AG 1) SV: Target set value (0.00) Symbol: Symbol of the target setting (SV) <ul style="list-style-type: none"> * If another area group number is shown, press AREA repeatedly until "AG 1" appears. ③ Set the target set value by using ▲ or ▼. <ul style="list-style-type: none"> * When you press the key, the decimal point starts blinking. * If the value does not contain a decimal fraction, a blinking decimal point appears next to the last digit. * Continuous pressure on the key will change the value rapidly.

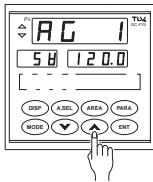
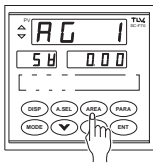

Step	Action
1	<p>④ Press ENT to register the new value.</p> <ul style="list-style-type: none"> * The decimal point will stop blinking. * If the value contains no decimal fraction, the decimal point next to the last digit disappears. * The example shows 120.0 set for target set value. <p>⑤ Set the PID constants as necessary.</p> <p>Refer to "Procedure-2 Setting the PID Constants with Auto-tuning" on page 40 or "8. PID Constants Manual Tuning Method" on page 103.</p> <ul style="list-style-type: none"> * This procedure assumes that you do not need to set the rest of the area items.
2	<ul style="list-style-type: none"> • Select AUT mode. <p>① Press MODE.</p> <p>AUT appears blinking in the SV display.</p> <p>② Press ENT.</p> <p>The controller switches to AUT mode and turns on the AUT lamp. The display changes to the display state automatically.</p> <ul style="list-style-type: none"> * AUT operation starts automatically at this point.
3	<ul style="list-style-type: none"> • Verify the operation panel display. <ul style="list-style-type: none"> * The control panel should display the following, as shown at right. <p>PV: Current measurement value (120.0) SV: Target set value of the area (120.0) Symbol: Area number + SV (1.SV)</p> <ul style="list-style-type: none"> * It will take longer when the new target set value is much larger or smaller than the current value.

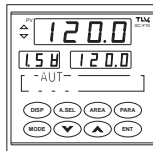
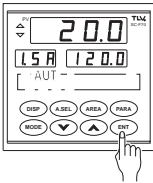
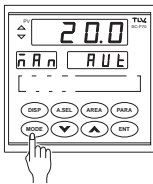
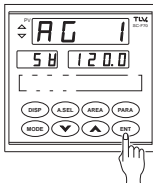

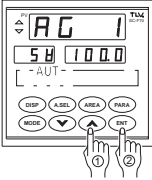
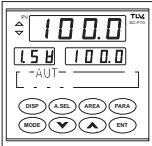
Step	Action
4	<p>• Change the target set value while the operation is in process.</p> <p>① Press AREA . * The display shown at right appears.</p>  <p>② Press Λ or V to set the new target value, and press ENT to register the change. * The example shows 100.0 as the new target.</p>  <p>③ Press DISP to see if the measurement value moves to the new target set value.</p> 
5	<p>• Stop operation to turn off the controller.</p> <p>① Press MODE to change the mode from AUT to MAN. * MAN blinks in the SV display.</p> <p>② Press ENT . * The mode changes to MAN from AUT.</p> <p>③ Press V until 0.0 appears in the SV display to shut off the valve.</p> <p>④ Turn off the controller and the valve power to stop operation.</p>
<p>Now, you have completed the automatic operation (LOC/AUT mode).</p>	

3.4 Area Switching Automatic Operation (LOC/AUT Mode)

In the previous section, only one area (AG01) is used for the target control. This section describes how to set up to 8 areas as needed. It also describes how to select the area number for operation.

Operation Procedure

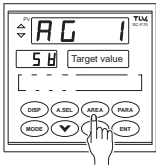
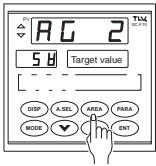
Step	Action
1	<ul style="list-style-type: none"> Select LOC/MAN mode. * If you need instruction, see page 25.
2	<ul style="list-style-type: none"> Set up the areas. * See page 23. <p>① Press AREA.</p> <p>The panel looks like the example at right: PV: Area group symbol (AG 1) SV: Target set value of the area Symbol: Symbol for the target setting (SV)</p>  <p>② Change the setting value of each item as desired. (See page 48 for the items you can set for each area)</p> <ol style="list-style-type: none"> Change the value by pressing Λ or V. Register the value by pressing ENT. Go to the next item by pressing ENT. Repeat steps a to c for all the items. <p>Note: Press only ENT when you do not need to alter the value in these steps.</p> <ul style="list-style-type: none"> * You can use Auto-tuning to set PID constants instead of manual setting in the Auto-tuning PID operation. Refer to "Procedure-2 Setting the PID Constants with Auto-tuning" on page 40. <p>③ Press AREA to move to Area No. 2. Area Group 2 (AG 2) will appear as shown at right. Set all items in the group as described in step .</p>  <p>④ Repeat steps ① to ③ above to set as many AREA groups as you want to use. * Each AREA must have its optimal PID constants.</p>

Step	Action
3	<ul style="list-style-type: none"> • Select the new area group number you want to use. * Refer to page 22. <p>① Press A.SEL.</p> <ul style="list-style-type: none"> * If group 2 is in process, the example shown at right appears. <p>PV: Current measurement value (100.0) Symbol: Area number. + item symbol (2.SV) SV: Target set value (120.0)</p> <p>Both the symbol and SV blink.</p> <p>② If the area number displayed is correct, press ENT.</p> <ul style="list-style-type: none"> * When you press ENT, the new area number operation becomes ready with the new target value and other control values, and the panel returns to the display state.
4	<ul style="list-style-type: none"> • Select LOC/AUT mode. * If you need instruction, see page 25. • The controller starts automatic operation with the preselected area group number. • If you want to use another group, press A.SEL until your target number appears. Each push of A.SEL increments the area number, and displays its target value. <p>Press ENT when the correct number is shown. Operation using the new area group starts immediately, and the panel returns to the display state automatically.</p> <ul style="list-style-type: none"> * You can select a new area without changing the mode to MAN for this operation.
This completes the area switching automatic operation procedure.	

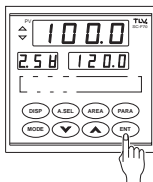

◆ Area Setting Values

The next table shows a summary of all AREA items.

These items are common to all AREA groups, AG1 through AG8.

No.	Symbol	Name	Description	Range	Factory Setting
1	SV — SV	Target setting	Defines the target value for the control. Note: The range is subject to the restrictions imposed by setting the measurement range lower and upper limits of the parameter. See PG10 on page 79.	Same as measurement range $SVL \leq SV \leq SVH$ [Measurement unit]	Measurement range lower limit
2	tM — tM	Soft start time	Sets the soft start time so that a new setting is implemented gradually. * A value of 0.00 sets the soft start to OFF. * This item is shown when SSL=0 in PG10.	0.00 - 99.59 Hr. min or min. sec (see Note 1)	0.00
2'	Sr — Sr	Setting change rate limiter	Places restrictions on the amount of change for each unit of time when settings are changed. * A value of 0 sets the setting change rate limiter to OFF. * This item is displayed when SSL=1 in PG10.	0~ measurement span or 9999 [Measurement unit/minute]	0
3 to 6	A1 to A4 — A1 to A4	Alarm 1 to alarm 4	Sets an alarm value. * The type of alarm is selected by the parameter settings. See PG04 on page 73.	For deviation alarm: 0 to the measurement span For measured alarm: Same as measurement range [Measurement unit]	See page 63
7	P — P	Proportional band (see Note 2)	Sets proportional band for the control output. * A value of 0.0 sets On and Off actions. * In the heating, cooling PID operation, a value of 0.0 sets On and Off actions for both heating and cooling.	0.0 to 999.9%	10.0

No.	Symbol	Name	Description	Range	Factory Setting
8	I — I	Integral time	Sets integral time for control output. * A value of 0 sets proportional action. * This item is not displayed when P=0.0.	0 to 3600 sec.	240
9	D — D	Differential time	Sets differential time for the control output. * A value of 0 sets proportional integral action. * This item is not displayed when P=0.0 or I=0.	0 to 3600 sec.	60
10	P_c — \bar{P}_c	Proportional band for cooling (see Note 3)	Sets proportional band for the control output for cooling. * A value of 0.0 sets On and Off actions. * Displayed in heating, cooling PID operation. * This item is not displayed when P=0.0.	0.0 to 999.9%	10.0
11	oH — $o\bar{H}$	Output limiter upper limit (see Note 2)	Restricts upper and lower limits for control output values. * oL is not displayed in heating, cooling PID operation. * This item is not displayed when the control output is a relay output, and P=0.0.	-5.0 to 105.0% * oL < oH	105.0
12	oL — $o\bar{L}$	Output limiter lower limit			-5.0
13	oH_c — oH_c	Output limiter upper limit for cooling	Restricts upper limit for cooling control output values. * Displayed in heating cooling PID operation. * This item is not displayed when the control output is a relay output, and P=0.0 or Pc=0.0.	-5.0 to 105.0%	105.0
14	$\bar{M}r$ — Mr	Manual reset (see Note 2)	Sets manual reset value. * This item is displayed when P≠0.0 and I=0.	-5.0 to 105.0%	0.0

No.	Symbol	Name	Description	Range	Factory Setting
15	$\bar{n}rc$ — Mrc	Manual reset for cooling	Sets the manual reset value for cooling control output. * This item is displayed when $P \neq 0.0$, $P_c \neq 0.0$, and $I=0$ in heating, cooling PID operation.	-5.0 to 105.0%	0.0
16	db — db	Dead zone (see Note 2)	[Auto-tuning PID operation] Adds db value to a target set value and compensates the target set value virtually in On and Off actions ($P=0.0$). * This item is displayed when $P=0.0$.	$\pm 10\%$ of the measurement span [Measurement unit]	0
			[Heating, cooling PID operation] Provides a control dead zone between the heating proportional band and the cooling proportional band.	$\pm 10\%$ of the measurement span [Measurement unit]	0
17	dbc — dbc	Dead zone for cooling	Provides a control dead zone between the heating proportional band and the cooling proportional band. * This item is displayed in heating, cooling PID operation.	$\pm 10\%$ of the measurement span [Measurement unit]	0
18	Cr — Cr	Control responsiveness selection (See Note 4)	Sets the responsiveness when the control setting has been changed.	0: Slow 1: Medium 2: Fast	0

Notes:

- The soft start time units can be set by the parameter PG10/SVGr, item No. 3 (see page 79). The factory default units are hour.minute.
- The parameter is set for heating in the heating, cooling PID operation.
- The Integral time I, and the Differential time d for cooling are automatically set to the same values as these parameters for heating.
- Refer to "3.5 Compensation for Control Responsiveness" on page 51 for selecting a value.

3.5 Compensation for Control Responsiveness

The Auto-tuning operation sets the PID constants that will take the best compensation actions against possible external disturbance. If you want to improve the control responsiveness, use the following procedure:

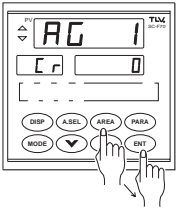
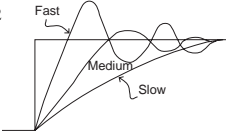
Step	Action
1	<p>① Press the AREA key until the Area number you want to set is displayed.</p> <p>② Press the ENT key until " [r " is displayed.</p> 
2	<p>Press the Λ or V key to select 0, 1, or 2 for setting.</p> <p>0: Slow Priority is given to suppressing overshooting. Rising is more gradual.</p> <p>1: Medium Intermediate between 0 and 2.</p> <p>2: Fast Priority is given to rising rapidly. Overshooting is inevitable.</p> <p>* The initial setting is 0. * Each setting affects the control output, as shown at right.</p> 

Notes:

1. A change in the responsiveness setting affects only the algorithm, not values of PID.
2. Cr must be set for each AREA.
3. If you cannot get enough improvement by setting the Cr, change the PID setting by referring to "3.6 PID Constants Fine Tuning Method" on page 52.

3.6 PID Constants Fine-Tuning Method

Determining the best PID constant values needs numerous trials. This section summarizes the relationship between the PID constants and control responsiveness. Use the following information to obtain fine-tuned PID constants.

1) Effect of Proportional Band (P)

If you decrease only the P value, responsiveness is affected as follows:

1. The offset amount decreases when the integral time is set to 0 seconds.
2. The first peak fluctuation of the measured value after controlling caused by external disturbance decreases.
3. The measured value oscillates more. The oscillation damping ratio becomes smaller and the measured value finally diverges.
4. The oscillation cycles shorten.

2) Effect of Integral Time (I)

When you decrease only the I value, responsiveness is affected as follows:

1. The offset amount can be decreased to zero.
2. The first peak fluctuation of the measured value after controlling caused by external disturbance decreases.
3. Overshooting becomes larger when the target setting is changed.
4. The measured value oscillates more. The oscillation damping ratio becomes smaller, and the measured value finally diverges.
5. The time the deviated value takes to return to the target value becomes shorter.

3) Effect of Differential Time (D)

When you decrease only the D value, responsiveness is affected as follows:

1. The first peak fluctuation of the measured value after controlling caused by external disturbance decreases.
2. Oscillation becomes suppressed. The oscillation damping ratio increases, but it decreases again if the D value is increased too much.
3. The oscillation cycles shorten.

3.7 PID Constants Setting and Control

Operation

(1) Auto-tuning PID operation

① ON-OFF operation ($P=0.0$)

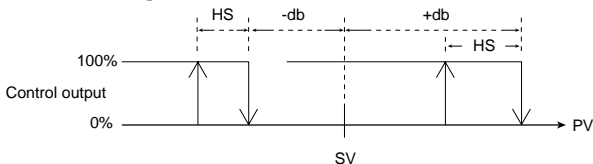

② Proportional operation ($P \neq 0.0, I=0$)

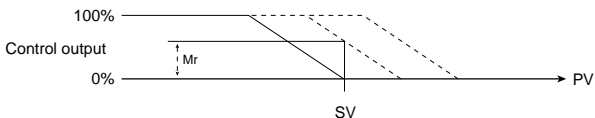

③ PID operation ($P \neq 0.0^*, I \neq 0^*$)

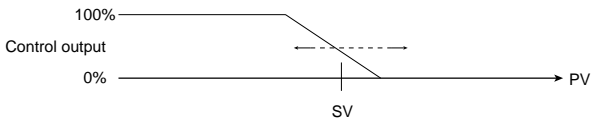

HS : hysteresis

db : dead zone

Mr : manual reset

* Optimum values for P, I, and D should be set by Auto-tuning or manual tuning.

(2) Heating, cooling PID operation

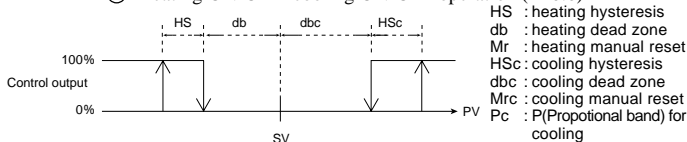
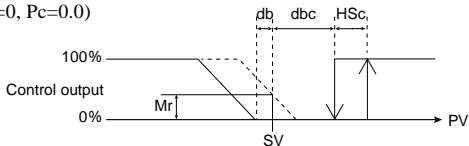
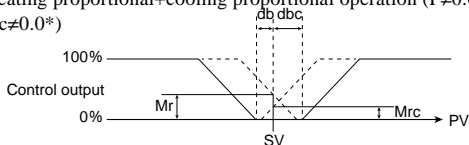
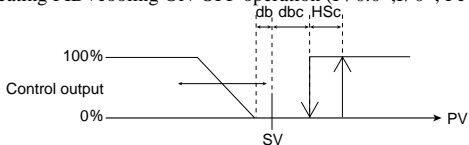
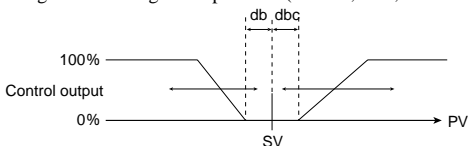
① heating ON-OFF+cooling ON-OFF operation ($P=0.0$)② heating proportional+cooling ON-OFF operation ($P \neq 0.0^*$, $I=0$, $Pc=0.0$)③ heating proportional+cooling proportional operation ($P \neq 0.0^*$, $I=0$, $Pc \neq 0.0^*$)④ heating PID+cooling ON-OFF operation ($P \neq 0.0^*$, $I \neq 0^*$, $Pc=0.0$)⑤ heating PID+cooling PID operation ($P \neq 0.0^*$, $I \neq 0^*$, $Pc \neq 0.0^*$)

* Optimum values for P, I, D, and Pc should be manually tuned.

4. Remote Operation (REM/AUT Mode)

Remote operation enables you to set the target value from a remote location in one of the following two ways:

- **Remote analog input operation**
Target values are set by using an externally connected analog input device.
- **Remote area switching operation**
Area selection is done by using a set of external contacts.

Users must specify which feature is to be included in the controller when their order is placed. Only one of the above (analog or area switching) can be included.

With either of these features, you can operate the controller from a remote site just as if you are standing in front of the operation panel.

4.1 Remote Analog Setting Operation

- The following setups must be done before starting the remote analog setting operation.
 1. Select the mode of analog input, current or voltage, by setting the analog input selection jumper by referring to page 7.
⚠ Warning:
Improper setting of this jumper may damage the controller.
 2. Setup all 6 items of parameter PG05/AiGr (analog setting input) by referring to page 75.
⚠ Warning:
Improper setting of the parameter PG05/AiGr may produce unexpected controller output.
 3. Connect the analog input device by referring to the following figure and tables.

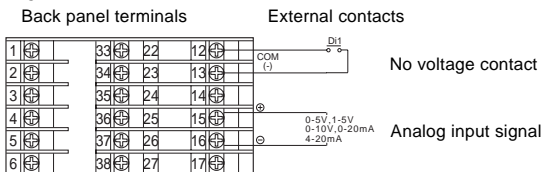

There are two ways to use contact point Di1 on previous page, as defined in the parameter PG06/DiGr item 1 (diS value): (refer to page 76)

diS value

0: MAN and AUT switching

1: LOC and REM switching

To start remote operation, set the mode to REM.

You can set REM mode either by setting the diS value to 1 and using the contact for it, or you can set it using the control panel. Select the diS value for the operation you plan to use.

Terminals 15 and 16 accept the analog input in either DC voltage or DC current, as shown on previous page. The analog signal corresponds to the target setting value.

◆ Contact Operation

● MAN and AUT Switching Plus Analog Input Contact Operation (diS = 0)

Terminal No.	Contact Action	Mode Switches To
No.12 - No.13(Di1)	Close to open Open to close	MAN mode (about 2 seconds later) AUT mode (about 2 seconds later)
No.15 - No.16	Analog input signal	

● LOC and REM Switching Plus Analog Input Contact Operation (diS = 1)

Terminals No.	Contact Action	Mode Switches To
No.12 - No.13(Di1)	Close to open Open to close	LOC mode (about 2 seconds later) REM mode (about 2 seconds later)
No.15 - No.16	Analog input signal	

◆ Remote Analog Input Operation

The next procedure describes how to run the controller using remote analog input.

Step	Action
1	<ul style="list-style-type: none"> Set the feature jumper to select current or voltage for the analog input. See "Analog Input Selection Jumper" on page 8.
2	<ul style="list-style-type: none"> Set all 6 items of PG05. See page 75.
3	<ul style="list-style-type: none"> Set the diS parameter of the PG06. See page 76.
4	<ul style="list-style-type: none"> Set the target value on the external analog input signal. Note: Do not change the mode to REM before the target value has been set. Otherwise, an unexpected analog value will result, or a set value input error will occur.
5	<ul style="list-style-type: none"> Set the mode to REM. Do the following on the operation panel (diS = 0): LOC → REM switching (Operation panel) ① Press MODE twice. * LOC and REM (blinking) appear on the Symbol and SV display, respectively. ② Press ENT. * The REM lamp of the status indicator turns on, and the panel changes to the display state. or Do the following if you use the external contact (on back panel) (diS = 1): LOC → REM switching (External contact) ① If Dil contact point is open, close it; if closed, open and close it.
6	<ul style="list-style-type: none"> Set the mode to AUT. Do the following on the operation panel (diS = 1): MAN → AUT switching (Operation panel) ① Press MODE once. * MAN and AUT (blinking) appear on the Symbol and SV display, respectively. ② Press ENT. The AUT lamp of the status indicator turns on, and the panel changes to the display state. or Do the following when you use the external contact (on back panel) (diS = 0): MAN → AUT switching (External contact) ① If Dil contact point is open, close it; if closed, open and close it.
7	<ul style="list-style-type: none"> Once this procedure is completed, only analog input value set by the external device will be accepted by the controller. Note: The analog input signal fluctuation must be less than ± 0.1 % F.S. If the fluctuation exceeds this, the controller may accept the fraction as a new set value, which can cause a hunting problem in the valve actuator.

4.2 Remote Area Switching Operation

This diagram shows the wiring of external contacts for remote area switching.

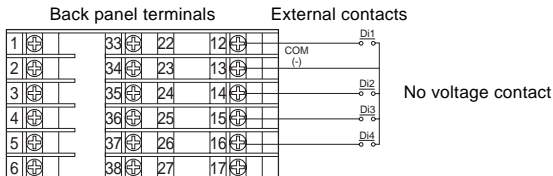

There are three ways to use these four points (Di1 - Di4), as defined in the parameter PG06/DiGr item 1 (diS value). See page 76.

diS value

- 0: MAN/AUT switching plus area selection
- 1: LOC/REM switching plus area selection
- 2: Area selection

To start remote operation, set the mode to REM.

You can set REM mode either by setting the diS value to 1 and using the contact for it, or you can set it using the control panel. Select the diS value for the operation you plan to use.

The next diagram shows how to allocate the contact points for the area number and switching functions.

• diS=0

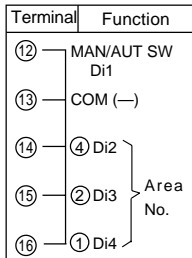

• diS=1

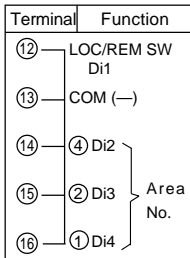

• diS=2

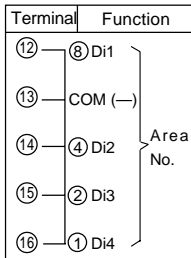

● **When Used for MAN/AUT Switching Plus Area Selection (diS = 0)**

The table shows the contact status for mode and area numbers.

Legend

X: Closed O: Open —:N/A

Terminals	Mode		Area Number Selected							
	MAN	AUT	1	2	3	4	5	6	7	8
13 - 12 (Di1)	X→O	O→X	—	—	—	—	—	—	—	—
13 - 14 (Di2)	—	—	O	O	O	O	X	X	X	X
13 - 15 (Di3)	—	—	O	O	X	X	O	O	X	X
13 - 16 (Di4)	—	—	O	X	O	X	O	X	O	X

Notes:

1. The new value given by the external contacts becomes effective after about 2 seconds.
2. Mode switching requests are honored by detecting a status change.
3. An area number is determined only by the status of the contact points.

● **When Used for LOC/REM Switching Plus Area Selection (diS = 1)**

This table shows the contact status for mode and area numbers.

Legend

X: Closed O: Open —: N/A

Terminals	Mode		Area Number Selected							
	LOC	REM	1	2	3	4	5	6	7	8
13 - 12 (Di1)	X→O	O→X	—	—	—	—	—	—	—	—
13 - 14 (Di2)	—	—	O	O	O	O	X	X	X	X
13 - 15 (Di3)	—	—	O	O	X	X	O	O	X	X
13 - 16 (Di4)	—	—	O	X	O	X	O	X	O	X

Notes:

1. The new value given by the external contacts becomes effective after about 2 seconds.
2. Mode switching requests are honored by detecting a status change.
3. An area number is determined only by the status of the contact points.

● **When Used for Area Selection (diS = 2)**

The next table shows the contact status for area numbers.

X: Closed O: Open

Terminals	Area Number Selected							
	1	2	3	4	5	6	7	8
13 - 12 (Di1)	O	O	O	O	O	O	O	X
13 - 14 (Di2)	O	O	O	X	X	X	X	O
13 - 15 (Di3)	O	X	X	O	O	X	X	O
13 - 16 (Di4)	X	O	X	O	X	O	X	O

Note:

1. The new value given by the external contacts becomes effective after about 2 seconds.
2. An area number is determined only by the status of the contact points.

◆ Remote Area Switching Operation

The next procedure describes how to run the controller using remote area switching.

Step	Action
1	<ul style="list-style-type: none"> Set the diS parameter of the PG06. See page 76.
2	<ul style="list-style-type: none"> Set the external contacts to a new area number for operation. Note: Do not change the mode to REM/AUT before a new area number setting is completed. Otherwise, an unexpected area number will be selected, or a selection error will occur.
3	<ul style="list-style-type: none"> Set the mode to REM. Do the following on the operation panel (diS = 0 and 2): LOC → REM switching (Operation panel) ① Press MODE twice. * LOC and REM (blinking) appear on the Symbol and SV display, respectively. ② Press ENT. * The REM lamp of the status indicator turns on, and the panel changes to display state. or Do the following if you use the external contact (on back panel) (diS = 1): LOC → REM switching (External contact) ① If Dil contact point is open, close it; if closed, open and close it.
4	<ul style="list-style-type: none"> Set the mode to AUT. Do the following on the operation panel (diS = 1 and 2): MAN → AUT switching (Operation panel) ① Press MODE once. * MAN and AUT (blinking) appear on the Symbol and SV display, respectively. ② Press ENT. * The AUT lamp of the status indicator turns on, and the panel changes to the display state. or Do the following when you use the external contact (on back panel) (diS = 0): MAN → AUT switching (External contact) ① If Dil contact point is open, close it; if closed, open and close it.
5	<ul style="list-style-type: none"> Once this procedure is completed, the new area number set by the external contacts is used by the controller.

5. Using Other Functions

In addition to the various functions introduced in the previous chapters, the controller lets you use other advanced functions.

1. Alarm
2. Transmission output
3. Communication (option)

This chapter introduces these functions and other useful hints. It concludes with information on what happens when power is lost.

5.1 Using Alarms

One good way to monitor the system operation performed by the controller is to utilize the alarm functions.

• Alarm Wiring

Up to four alarm points (AL1, AL2, AL3*¹ and AL4*²) can be used and should be wired as shown in the diagram.

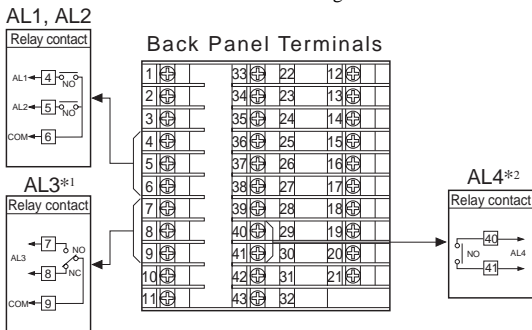

*1: Cannot be used if the control output or the heating control output is a relay contact output.

*2: Cannot be used if the cooling control output is a relay contact output in the heating, cooling PID operation.

• Types of Alarm

The following types of alarms can be selected by setting the parameters PG04/ALGr for each alarm, AL1 to AL4. See page 73. When you select a type of alarm, alarm control values are initialized to their defaults, as shown in the next table. If needed, you can change the settings to the values that best suit your requirements.

Type	Description	Default value set in PG02
0	Alarm is not used.	Not set/ Not displayed
1	Alarm activates when measurement value exceeds the upper limit of the range.	Upper limit
2	Alarm activates when measurement value exceeds the lower limit of the range.	Lower limit
3	Alarm activates when deviation value exceeds the preset value ($PV > SV$).	Measurement span (Note 1)
4	Alarm activates when deviation value goes below the preset alarm value ($PV < SV$).	Measurement span (Note 1)
5	Alarm activates when deviation exceeds either upper or lower limits.	Measurement span (Note 1)
6	Alarm activates when deviation value stays within the preset alarm value.	Measurement span (Note 1)
7	Same as Type 1 with standby operation (Note 2).	Upper limit
8	Same as Type 2 with standby operation (Note 2).	Lower limit
9	Same as Type 3 with standby operation (Note 2).	Measurement span (Note 1)
10	Same as Type 4 with standby operation (Note 2).	Measurement span (Note 1)
11	Same as Type 5 with standby operation (Note 2).	Measurement span (Note 1)
12	Alarm activates when input error occurs (Note 4).	Not set/ Not displayed
13	Alarm activates when a failure is detected (FAIL lamp lit) (Note 3).	Not set/ Not displayed

Notes:

1. The Measurement span is the difference between the upper and lower limits of the measurement range (upper limit minus lower limit). Differential greater than 9999 is limited to 9999.
2. The Standby operation ignores the alarm if the alarm condition occurs immediately after the target value is changed. When the measurement value drops within the normal range, however, and then the alarm condition is again satisfied, the alarm is activated. As a result, the standby operation separates a real alarm from a usual time lag alarm because of a sudden target change.
3. Alarm relay contact is open for no alarm state, and is closed when alarm conditions are met.
4. Inputs to be monitored are measurement input, analog setting input, and area switching input.

• Using the Alarm

This procedure describes how to use the alarm.

Step	Action				
1	<ul style="list-style-type: none"> Wired the back panel terminals to set up the alarm for AL1 to AL4 (see page 62). 				
2	<ul style="list-style-type: none"> Determine and set the parameter PG04 for the type of alarm, the excitation, the hysteresis, and the timer. (see page 73) <p>Note: The Exciting or Non-exciting parameter controls the alarm relay contacts as follows:</p> <table border="1"> <tbody> <tr> <td>Exciting</td> <td>Normally open contacts close when alarm is activated</td> </tr> <tr> <td>Non-exciting</td> <td>Normally open contacts open when alarm is activated</td> </tr> </tbody> </table> <p>In both cases, Normally closed points act conversely.</p>	Exciting	Normally open contacts close when alarm is activated	Non-exciting	Normally open contacts open when alarm is activated
Exciting	Normally open contacts close when alarm is activated				
Non-exciting	Normally open contacts open when alarm is activated				
3	<ul style="list-style-type: none"> Determine and set the alarm values in the AREA you plan to use. 				
4	<ul style="list-style-type: none"> Start your control operation. * If needed, create the alarm condition artificially to test your alarm setup. 				
5	<ul style="list-style-type: none"> Monitor the alarms. 				

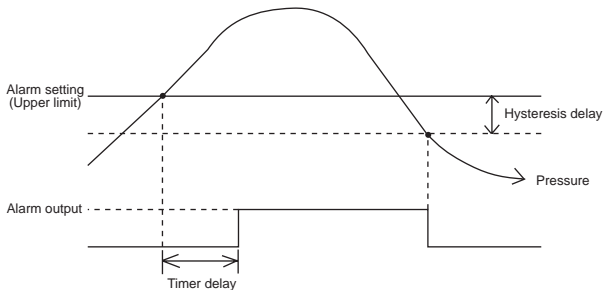

Timer: Delays the alarm output activation.

Hysteresis: Delays the alarm output deactivation.

Use of these timer and hysteresis delays provides additional control to prevent frequent alarm activation due to the unstable pressure.

5.2 Using the Transmission Output

Up to three transmission outputs are available from the controller. These outputs can be fed to devices, such as a pen-recorder or indicator.

The diagram shows back panel terminal assignments and wiring for transmission output. All three outputs are in electrical DC current.

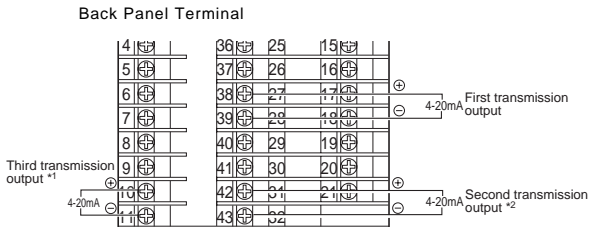

The type of control value transmitted from each output is determined by the value in each item of the parameter PG07/AoGr (see page 76) as follows:

Item No.1 is for first transmission output, and item No. 4 is for second transmission output, and Item No.7 is for third transmission output.

- 0: Measurement value
- 1: Deviation value
- 2: Target set value
- 3: Control output value (heating control output value in the heating, cooling PID operation)
- 4: Cooling control output value (specified in the heating, cooling PID operation)

*1: If the control output is a current output, the third transmission output cannot be used.

*2: If the cooling control output is a current output in the heating, cooling PID operation, the second transmission output cannot be used.

5.3 Using the Communication Functions

When the controller is equipped with communication functions, a remotely installed personal computer (PC) can perform all functions that would normally be done locally on the operation panel.

The communication functions enable you to read from or write to any or all of, the AREAs and PARAMETERS.

Each controller can have a unique device address so that multiple controllers (to a maximum of 31) can be controlled by one PC.

◆ Communication Specifications

Use one of the following interface types (specify with order):

- EIA RS-422A: 4-wire multidrop connection
- EIA RS-485: 2-wire multidrop connection
- EIA RS-232C: 3-wire point-to-point connection

See page 112 for other specifications.

For operation details, refer to the "SC-F70 Multicontroller Operating Instructions for Communications" booklet.

5.4 Using Other Convenient Features

The following commonly used features enable more sophisticated operation.

1. Starting automatic operation just after the controller is turned on:
 - Set item No.5 (MSL) of the parameter PG08 to '1'.
 2. Shutting off the valve output from a remote location:
 - Set item No.3 (MMV) of the parameter PG08 to '3', and at the appropriate time, change the operation mode to MAN by remote contact input.*
 3. Preventing the controller from being set above (or below) the predetermined pressure level by an operator:
 - Set item No.1(SVL) or 2(SVH) of the parameter PG10 to the upper or lower limiter value.
- * This operation can be done only when the control valve actuator moves in reverse. In addition, the description is valid only for the heating portion of the heating, cooling PID operation.

5.5 What Happens When Power Is Lost?

When the controller power is lost, the control output is also lost. The controller operation is the same as when the control output is not available.

To shut down the control fluid supply when the controller power is lost, install an additional shutdown valve which closes when power is lost.

6. Summary of PARAMETER Groups and AREAs

This chapter summarizes all PARAMETER groups and AREAs in tables beginning on the next page.

6.1 Parameters

Parameters are grouped in 10 related families (PG02 through PG10, and PG12). To change the value in the parameters, you must set the controller in MAN mode, if in AUT mode, precedently.

1. PG02/PVGr (measurement input)

No.	Symbol	Name	Description	Range	Factory setting
1	PVI	Measurement input type	To set this value, see the table of Measurement Input Types and Ranges shown on next page.	0 to 701	Depends on order specifications.
2	PVL	Lower limit of measurement input range	These values are used to set a range for the sensor used. * When the PVI range is set between 0 to 511, these parameters do not appear.	-199.9 to 999.9 (See Note1) 1. $PVL < PVH$ 2. For decimal position, see item No. 6.	Depends on order specifications.
3	PVH	Upper limit of measurement input range			
4	PVF	Measurement input filter	Applies a first-order lag to reduce noise from measurement input.	0 to 100 sec.	0
5	PVb	Measurement input bias	Applies bias to measurement input for sensor accuracy correction.	$\pm 5\%$ of measurement span [Measurement unit] (See Note 2)	0.00
6	PVr	Extraction of the square root of measurement input	Specifies if an extraction function of the square root is required. * This parameter is displayed only when the measurement type PVI is set to 600-701.	0: Not required 1: Required	0
7	PVc	Low-cut of measurement input	Cuts low values and measurements that may amplify the result of the extraction of the square root. * This parameter is displayed only when $PVr=1$.	0.00 ~ 25.00%	0.00
8	dp	Decimal position	Designates the decimal position for measurement input by the number of digits after the point. (See Note 3)	0 - 3	Depends on order specifications.

Note 1: Use the same unit system as the measurement unit of the control target.

Note 2: Use the same unit system as the measurement unit which is used for the upper limit and the lower limit of the measurement input range. When the measurement input type is 0 ~ 511, use the corresponding unit of °C or °F.

Note 3: When the decimal position is changed, set the upper limit and the lower limit of the measurement input range, and all items set with the measurement unit.

Measurement Input Types and Ranges

Group	Sensor	Input Range	Setting	Group	Sensor	Input Range	Setting	Group	Sensor	Input Range	Setting
Thermo-couple	K	0.0~400.0°C	0	Thermo-couple	K	0.0~800.0°F	200	Voltage Input	Low	0~10mV	600
		0.0~800.0°C	1			0~100mV	601				
	J	0.0~400.0°C	10		J	0.0~700.0°F	210			0~1V	602
		0.0~800.0°C	11			E	0.0~999.9°F			220	0~5V
	E	0.0~700.0°C	20		T		0.0~700.0°F			230	1~5V
	T	0.0~400.0°C	30		U	0.0~999.9°F	240			0~10V	612
U	0.0~600.0°C	40	L	0.0~700.0°F	250	Current Input	0~20mA	700			
L	0.0~400.0°C	50	RTD	JPt	0.0~600.0°F		500	4~20mA	701		
RTD	JPt	0.0~300.0°C		400	100	0.0~900.0°F	501				
		0.0~500.0°C		401	Pt	0.0~600.0°F	510				
	Pt	0.0~300.0°C		410	100	0.0~999.9°F	511				
	100	0.0~600.0°C		411							

2. PG03/MVGr (Control output)

No.	Symbol	Name	Description	Range	Factory setting
1	ot	Control output type (see Note 1)	Specifies output type for the control output and for the cooling control output. * otc is displayed in the heating, cooling PID operation.	0: Current output 1: Relay output	0
2	otc	Control output type for cooling			1
3	oS	Control output forward or reverse selection	Used to select the type of control output (forward or reverse). * Displayed in the auto-tuning PID operation. * In the heating, cooling PID operation, the movement is always reverse for heating, and always forward for cooling.	0: Reverse 1: Forward	0
4	HS	Hysteresis (see Note 1)	Sets the hysteresis for the ON-OFF operation. * HSc is displayed in the heating, cooling PID operation.	0 ~10% of measurement span [measurement unit]	0.1% of measurement span
5	HSc	Hysteresis for cooling			
6	or	Output change rate limiter	Imposes restrictions on the amount of change per unit of time when control output values are changed. * The change rate limiter is OFF when the value is set to 0.0.	0.0 ~100.0 %/second	0.0

No.	Symbol	Name	Description	Range	Factory setting
7	\overline{CY}	Time proportional period (see Note 1)	For current control output: Sets the renewal period for control output.	For current output: 0.0~100seconds * When set to 0, minimum 250 msec.	0
8	\overline{CYc}	Time proportional period for cooling	For relay control output: Sets the proportional period for control output. * CYc is displayed in the heating, cooling PID operation.	For relay output: 1~100seconds	20

Note 1: This parameter is set for the heating in the heating, cooling PID operation.

3. PG04/ALGr (Alarm output)

No.	Symbol	Name	Description	Range	Factory setting
1	$\overline{AL1}$	Type for Alarm 1	Selects the type of alarm for AL1.	0-13 (Note 1)	3
2	\overline{ALc}	Exciting or non-exciting for AL1	Selects whether the alarm is an exciting or non-exciting type.	0: Exciting 1: Non-exciting (Note 4)	0
3	$\overline{A1H}$	Hysteresis for AL1	Sets the hysteresis for the alarm.	0-10% of measurement span (Note 5)	0.1% × Span
4	$\overline{A1t}$	Timer for AL1	Sets the delay between the time the value enters the alarm range and the time the alarm turns on.	0-600 sec.	0
5	$\overline{AL2}$	Type for Alarm 2	Selects the type of alarm for AL2.	0-13 (Note 1)	4
6	$\overline{A2c}$	Exciting or non-exciting for AL2	Selects whether the alarm is an exciting or non-exciting type.	0: Exciting 1: Non-exciting (Note 4)	0
7	$\overline{A2H}$	Hysteresis for AL2	Sets the hysteresis for the alarm.	0-10% of measurement span (Note 5)	0.1% × Span
8	$\overline{A2t}$	Timer for AL2	Sets the delay between the time the value enters the alarm range and the time the alarm turns on.	0-600 sec.	0
9	$\overline{AL3}$	Type for Alarm 3 (See Note 6)	Selects the type of alarm for AL3.	0-13 (Note 1)	1
10	$\overline{A3c}$	Exciting or non-exciting for AL3 (See Note 6)	Selects whether the alarm is an exciting or non-exciting type.	0: Exciting 1: Non-exciting (Note 4)	0
11	$\overline{A3H}$	Hysteresis for AL3 (See Note 6)	Sets the hysteresis for the alarm.	0-10% of measurement span (Note 5)	0.1% × Span
12	$\overline{A3t}$	Timer for AL3 (See Note 6)	Sets the delay between the time the value enters the alarm range and the time the alarm turns on.	0-600 sec.	0
13	$\overline{AL4}$	Type for Alarm 4 (See Note 7)	Selects the type of alarm for AL4.	0-13 (Note 1)	2

No.	Symbol	Name	Description	Range	Factory setting
14	<u>A4c</u> A4c	Exciting or non-exciting for AL4 (See Note 7)	Selects whether the alarm is an exciting or non-exciting type.	0: Exciting 1: Non-exciting (Note 4)	0
15	<u>A4H</u> A4H	Hysteresis for AL4 (See Note 7)	Sets the hysteresis for the alarm.	0-10% of measurement span (Note 5)	0.1% × Span
16	<u>A4t</u> A4t	Timer for AL4 (See Note 7)	Sets the delay between the time the value enters the alarm range and when the alarm turns on.	0-600 sec.	0
17	<u>ASL</u> ASL	Alarm in MAN mode	Selects whether an alarm operates occurs in MAN mode.	0: Occurs 1: Does not occur	0

Notes:

1. If you select a type for the alarm, the alarm set value in the AREAs are reset to default values as follow:
(For the details, see "Types of Alarm" on page 63.)

Type of Alarm

- 0: No alarm
- 1: Measurement upper limit
- 2: Measurement lower limit
- 3: Deviation upper limit
- 4: Deviation lower limit
- 5: Deviation upper and lower limits
- 6: Within deviation range
- 7: Measurement upper limit with standby operation
- 8: Measurement lower limit with standby operation
- 9: Deviation upper limit with standby operation
- 10: Deviation lower limit with standby operation
- 11: Deviation upper and lower limits with standby operation
- 12: Input error
- 13: FAIL alarm

Default Setting in the Area

- No alarm setting display
Upper limit of measurement range
Lower limit of measurement range
Measurement span or 9999
Measurement span or 9999
Measurement span or 9999
Measurement span or 9999
Upper limit of measurement range (see Note 2)
Lower limit of measurement range (see Note 2)
Measurement span or 9999 (see Note 2)
Measurement span or 9999 (see Note 2)
Measurement span or 9999 (see Note 2)
No alarm setting display (see Note 3)
No alarm setting display

2. The alarm standby operation is active when the power is turned on, when target settings are changed in AUT mode, and when the mode is changed from MAN to AUT.
It is suppressed in REM analog input mode operation even if alarm with standby operation is selected.
3. The input error refers to an error in measurement input, remote analog setting input, or external area selection input.
4. Exciting refers to the excitation of the alarm relay when an alarm condition is met, resulting in the N/O contact of the alarm relay to close.
Conversely, non-exciting means the NO contact will open.
5. Use the same unit specified in the measurement input unit.
6. This item is not displayed, if the control output (the heating control output when in the heating, cooling PID operation) is a relay output.
7. This item is not displayed if the cooling control output is a relay output in the heating, cooling PID operation.

4. PG05/AiGr (Analog setting input)

This group applies only when an analog setting input option is installed (specified with order).

No.	Symbol	Name	Description	Range	Factory setting
1	\overline{rSl}	Analog setting input	Selects the types of analog setting input	0:DC 0 - 5 V 1:DC 1 - 5 V 2:DC 0 - 10 V 3:DC 0 - 20mA 4:DC 4 - 20mA	4 or specify with order
2	\overline{rSL}	Lower limit for analog setting input	Selects the range for analog setting input	Same as measurement range ($rSL < rSH$) (Note)	Range lower limit
3	\overline{rSH}	Upper limit for analog setting input			Range upper limit
4	\overline{rSF}	Filter for analog input	Uses primary delay filter to reduce the noise in analog setting input	0-100 sec.	0
5	\overline{rSb}	Bias for analog input	Adds a bias value to the input for correction	$\pm 5\%$ of measurement span (Note)	0
6	\overline{rSr}	Extraction of the square root of setting input	Specifies if an extraction function of the square root is required.	0: Not Required 1: Required	0
7	\overline{rSc}	Low-cut of setting input	From the result of the extraction of the square root, cuts all sharply rising result signals whose amplitude is low. * This value is displayed when $rSr=1$	0.00~25.00%	0.00
8	\overline{rSt}	Remote setting tracking	Selects whether a REM analog mode setting should be replaced with LOC mode target settings when the mode is changed from REM to LOC.	0: No tracking 1: Tracking	0

Note: Use the same unit specified in the measurement input unit.

5. PG06/DiGr (Area switching contact input)

No.	Symbol	Name	Description	Range	Factory setting
1	d_{IS} dIS	Contact input function	Selects the function for the contact input terminals	0-1 or 0-2 (Note)	0

Note: On models equipped with analog setting input:

0: MAN/AUT changing and analog setting input

1: LOC/REM changing and analog setting input

On models equipped with area switching contact input:

0: MAN/AUT changing and area selection





1: LOC/REM changing and area selection

2: Area selection

6. PG07/AoGr (Transmission output)

No.	Symbol	Name	Description	Range	Factory setting
1	$Ao1$ Ao1	Type for transmission output 1	Select the type for transmission output 1.	0: Measured value 1: Deviation 2: Target setting 3: Control output 4: Cooling control output (Note 1)	0
2	$1.AL$ 1.AL	Lower limit for transmission output 1	Select the output range for transmission output 1.	When: Ao1 = 0 or 2: same as measurement range (Note 2) Ao1 = 1: ±measurement span (Note 2) Ao1 = 3 or 4: 0.0~100.0% (1.AL < 1.AH)	Lower limit
3	$1.AH$ 1.AH	Upper limit for transmission output 1			Upper limit
4	$Ao2$ Ao2	Type for transmission output 2	Select the type for transmission output 2. * This item is not displayed when the cooling control output is a current output in the heating, cooling PID operation.	0: Measured value 1: Deviation 2: Target setting 3: Control output 4: Cooling control output (Note 1)	2

6. PG07/AoGr (Transmission output)

No.	Symbol	Name	Description	Range	Factory setting
5	 2.AL	Lower limit for transmission output 2	Select the output range for transmission output 2. * This item is not displayed when the cooling control output is a current output in the heating, cooling PID operation.	When: Ao2 = 0 or 2: same as measurement range (Note 2) Ao2=1: ±measurement span (Note 2) Ao2=3 or 4: 0.0~100.0% (2.AL < 2.AH)	Lower limit
6	 2.AH	Upper limit for transmission output 2			Upper limit
7	 Ao3	Type for transmission output 3	Select the type for transmission output 3. * This item is not displayed when the control output is a current output.	0: Measured value 1: Deviation 2: Target setting 3: Control output 4: Cooling control output (Note 1)	3
8	 3.AL	Lower limit for transmission output 3	Select the output range for transmission output 3. * This item is not displayed when the control output is a current output.	When: Ao3 = 0 or 2: same as measurement range (Note 2) Ao3=1: ±measurement span (Note 2) Ao3=3 or 4: 0.0~100.0% (3.AL < 3.AH)	Lower limit
9	 3.AH	Upper limit for transmission output 3			Upper limit

Notes: 1. The cooling control output can be selected in the heating, cooling PID operation.

2. Use the same unit specified in the measurement input unit.

7. PG08/ErGr (Operation)

No.	Symbol	Name	Description	Range	Factory setting
1	\overline{IPE} — IPE	Operation during input error (Note 1)	Selects the control output value during a measurement input error, analog setting input error, or area selection input error. • Operates only in AUT mode.	0: Held at the value just before error occurred 1: Held at the preset value 2: Held at output limiter lower limit (Note 4) 3: Held at 0%	0
2	\overline{AtE} — AtE	Operation during auto-tuning error (Notes 1, 2)	Selects the action taken when an error occurs during the auto-tuning process. • Not displayed in the heating cooling PID operation.	0: Held at value just before AT was started 1: Held at preset value 2: Held at output limiter lower limit 3: Held at 0%	0
3	\overline{lot} — lot	Output value after power restoration (Note 1)	Selects the initial control output value at power restoration.	0: 0% 1: Preset value 2: Output limiter lower limit (Note 4) 3: Value just before power was cut off	0
4	\overline{MMV} — MMV	Output value for MAN mode change (Note 1)	Selects the control output value when the mode is changed from AUT to MAN.	0: Bump-less transition 1: Preset value 2: Output limiter lower limit (Note 4) 3: 0%	0
5	\overline{PrV} — PrV	Preset control output	Sets the control output preset value used for No. 1, 2, and 3 in this table. (Note 5)	-5.0 to 105.0%	0.0
6	\overline{MSL} — MSL	Operation after power restoration (Note 3)	Selects the initial mode when power is restored.	0: LOC/MAN 1: LOC/AUT 2: REM/MAN 3: REM/AUT 4: Mode when power was interrupted	0
7	\overline{Sft} — Sft	Starting point for soft start	Selects the start point for soft start control at startup or when mode has been changed from MAN to AUT.	0: Start at measured value 1: Start at zero point	0

Note: 1. No matter what is specified in this item, the control output is limited by the setting of the output upper or lower limiter. However, the control output becomes 0% when the control output is a relay output and in On-Off action (P=0.0).

2. When 1, 2, or 3 is specified in this item, and an Auto-tuning error occurs, an error code (E11 to E13) is displayed, until the $\text{\textcircled{DISP}}$ key is pressed.







3. Even if power restoration mode has been selected, mode selection with the external contact input, if used, overrides.
4. The control output becomes 0.0 for both heating and cooling in the heating, cooling PID operation.
5. This value becomes the preset value of the heating control output in the heating, cooling PID operation. The preset value of the cooling control output becomes 0.0.

8. PG09/AtGr (Auto-tuning)

The item of this group is not displayed in the heating, cooling PID operation.

No.	Symbol	Name	Description	Range	Factory setting
1	 Atb	Auto-tuning bias	Normally Auto-tuning on-off control is based on the target setting. When an Auto-tuning bias is set, Auto-tuning is based on the target setting plus the Atb value.	\pm measurement span or 9999	0

9. PG10/SVGr (Settings)

No.	Symbol	Name	Description	Range	Factory setting
1	 SVL	Setting limiter lower limit	Sets limiters for the lower and upper limits to restrict the range of target setting.	Same as measurement range. <small>(See Note)</small> SVL < SVH	Lower limit
2	 SVH	Setting limiter upper limit			Upper limit
3	 tMS	Soft start time unit	Selects the unit for the AREA setting soft start.	0: Hour.Minute 1: Minute.Second	0
4	 SSL	Soft start or change rate limiter selection.	Selects which is used for the AREA setting: a soft start time or a setting change rate limiter.	0: Soft start 1: Setting change rate limiter	0
5	 dVu	Deviation range for Up deviation LED	Sets the deviation range within which the Up and Down deviation LED will light up.	0~ measurement span <small>(See Note)</small>	5% \times span
6	 dVd	Deviation range for Down deviation LED			
7	 LoK	Setting lock	Selects which settings are locked.	0: All unlocked 1: Parameter settings locked 2: All locked	0

Note: Use the same unit specified in the measurement input unit.

10. PG12/CMGr (Communication)

This group is displayed only on models equipped with the communication function, specified with purchase order.

No.	Symbol	Name	Description	Range	Factory setting
1	$\begin{array}{c} b \text{ } l \text{ } t \\ \text{---} \\ \text{b} \text{ } l \text{ } t \end{array}$	Communication setting	Selects the bit configuration for communication data.	0 - 11 (See Note 1)	0
2	$\begin{array}{c} A \text{ } d \text{ } d \\ \text{---} \\ \text{A} \text{ } d \text{ } d \end{array}$	Device address	Sets the device address for the controller.	0 - 99	0
3	$\begin{array}{c} b \text{ } P \text{ } S \\ \text{---} \\ \text{b} \text{ } P \text{ } S \end{array}$	Baud rate	Selects the baud rate (communication speed).	0 - 4 (See Note 2)	3
4	$\begin{array}{c} I \text{ } n \text{ } t \\ \text{---} \\ \text{I} \text{ } n \text{ } t \end{array}$	Interval	Select the proper interval to ensure the correct timing for transmitting and receiving.	0 - 250 msec.	0

Notes:

1. Communication Settings

Setting	Parity bits	Data bits	Stop bits
0	None	8	1
1	None	8	2
2	Even	8	1
3	Even	8	2
4	Odd	8	1
5	Odd	8	2
6	None	7	1
7	None	7	2
8	Even	7	1
9	Even	7	2
10	Odd	7	1
11	Odd	7	2

2. Baud rates





- 0: 1200 bps
- 1: 2400 bps
- 2: 4800 bps
- 3: 9600 bps
- 4: 19200 bps

6.2 Areas

The next table shows a summary of all area items.
These items are common to all area groups, AG1 through AG8.

No.	Symbol	Name	Description	Range	Factory Setting
1	SV — SV	Target setting	Defines the target value for the control. Note: The range is subject to the restrictions imposed by setting the measurement range lower and upper limits of the parameter. See PG10 on page 79.	Same as measurement range $SVL \leq SV \leq SVH$ [Measurement unit]	Measurement range lower limit
2	tM — tM	Soft start time	Sets the soft start time so that a new setting is implemented gradually. * A value of 0.00 sets the soft start to OFF. * This item is shown when SSL=0 in PG10.	0.00 - 99.59 Hr. min or min. sec (see Note 1)	0.00
2'	Sr — Sr	Setting change rate limiter	Places restrictions on the amount of change for each unit of time when settings are changed. * A value of 0 sets the setting change rate limiter to OFF. * This item is displayed when SSL=1 in PG10.	0~ measurement span or 9999 [Measurement unit/minute]	0
3 to 6	A1 to A4 — A1 to A4	Alarm 1 to alarm 4	Sets an alarm value. * The type of alarm is selected by the parameter settings. See PG04 on page 73.	For deviation alarm: 0 to the measurement span For measured alarm: Same as measurement range [Measurement unit]	See page 63
7	P — P	Proportional band (see Note 2)	Sets proportional band for the control output. * A value of 0.0 sets On and Off actions. * In the heating, cooling PID operation, a value of 0.0 sets On and Off actions for both heating and cooling.	0.0 to 999.9%	10.0

No.	Symbol	Name	Description	Range	Factory Setting
8	I — I	Integral time	Sets integral time for control output. * A value of 0 sets proportional action. * This item is not displayed when P=0.0.	0 to 3600 sec.	240
9	d — d	Differential time	Sets differential time for the control output. * A value of 0 sets proportional integral action. * This item is not displayed when P=0.0 or I=0.	0 to 3600 sec.	60
10	Pc — $\bar{P}c$	Proportional band for cooling (see Note 3)	Sets proportional band for the control output for cooling. * A value of 0.0 sets On and Off actions. * Displayed in heating, cooling PID operation. * This item is not displayed when P=0.0.	0.0 to 999.9%	10.0
11	oH — $o\bar{H}$	Output limiter upper limit (see Note 2)	Restricts upper and lower limits for control output values. * oL is not displayed in heating, cooling PID operation. * This item is not displayed when the control output is a relay output, and P=0.0.	-5.0 to 105.0% * oL < oH	105.0
12	oL — $o\bar{L}$	Output limiter lower limit			-5.0
13	oHc — $o\bar{H}c$	Output limiter upper limit for cooling	Restricts upper limit for cooling control output values. * Displayed in heating cooling PID operation. * This item is not displayed when the control output is a relay output, and P=0.0 or Pc=0.0.	-5.0 to 105.0%	105.0
14	$\bar{M}r$ — $M\bar{r}$	Manual reset (see Note 2)	Sets manual reset value. * This item is displayed when P≠0.0 and I=0.	-5.0 to 105.0%	0.0

No.	Symbol	Name	Description	Range	Factory Setting
15	 Mrc	Manual reset for cooling	Sets the manual reset value for cooling control output. * This item is displayed when $P \neq 0.0$, $P_c \neq 0.0$, and $I = 0$ in heating, cooling PID operation.	-5.0 to 105.0%	0.0
16	 db	Dead zone (see Note 2)	[Auto-tuning PID operation] Adds db value to a target set value and compensates the target set value virtually in On and Off actions ($P = 0.0$). * This item is displayed when $P = 0.0$.	$\pm 10\%$ of the measurement span [Measurement unit]	0
			[Heating, cooling PID operation] Provides a control dead zone between the heating proportional band and the cooling proportional band.	$\pm 10\%$ of the measurement span [Measurement unit]	0
17	 dbc	Dead zone for cooling	Provides a control dead zone between the heating proportional band and the cooling proportional band. * This item is displayed in heating, cooling PID operation.	$\pm 10\%$ of the measurement span [Measurement unit]	0
18	 Cr	Control responsiveness selection (See Note 4)	Sets the responsiveness when the control setting has been changed.	0: Slow 1: Medium 2: Fast	0

Notes:

- The soft start time units can be set by the parameter PG10/SVGr, item No. 3 (see page 79). The factory default units are hour.minute.
- The parameter is set for heating in the heating, cooling PID operation.
- The Integral time I, and the Differential time d for cooling are automatically set to the same values as these parameters for heating.
- Refer to "3.5 Compensation for Control Responsiveness" on page 51 for selecting a value.

7. Troubleshooting

When the control system does not work correctly, you can isolate the problem, analyze it, and resolve it using the following approach.

1. Using the "Isolating the problem area procedure," identify the specific area of the system where the trouble has occurred.
2. Refer to the section "Troubleshooting Guide" for the isolated area, and analyze the problem further to resolve the problem.

7.1 Problem Area

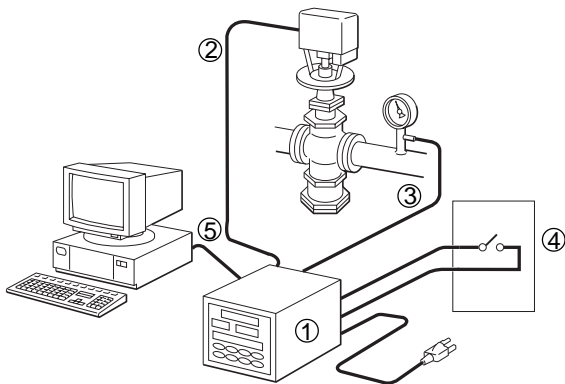

Generally, the controller system problems are categorized as follows:

- ① Controller problem
- ② Actuator control problem
- ③ Sensor problem
- ④ Remote external input problem
- ⑤ Communication problem

Each of them has the characteristics described in the following pages.

① Controller problems

The controller has a self-test function that checks the internal logic validity and the voltage. If an internal error is detected, the FAIL lamp comes on to let the operator know.

The controller also checks the validity of key inputs, the input value from the sensor, and inputs from external contacts. If invalid inputs are detected, the controller displays an error code according to the error source.

The controller problems fall into two categories:

- Error-displayable controller problems
- No error-displayable controller problems

② Actuator control problems

The controller supplies the output developed from the target value and other control factors to the actuator. There are three types of actuator control problems.

- Actuator itself or its wiring problems
- Controller output problems
- Setting errors or usage outside of specifications

③ Sensor problems

The controller receives a measured signal from the sensor, shows it on the Measurement Display on the panel, or calculates the deviations. There are three types of sensor-related problems.

- Sensor itself or its wiring problems
- Controller receiving problems
- Setting errors or usage outside of specifications

④ Remote external input problems

If the controller works without any problems in LOC mode, but experiences a problem when used in REM mode with external contacts, it may be an external contact or external analog input device problem. There are three types of external contact problems.

- External contact or wiring problems
- External analog input device or wiring problems
- Setting errors or usage outside of specifications

⑤ Communication Problems

If the controller works without any problems in all modes but experiences a problem when used for communications, it may be a communication problem. There are two types of communication problems.

- Controller communication problems
- PC (personal computer) or line communication problems

◆ Isolating the Problem Area

Determine your problem area by using the decision charts.

Perform the instructions in the center boxes, answer the questions in the diamond, and then go to the page shown under the determined-problem-area box.

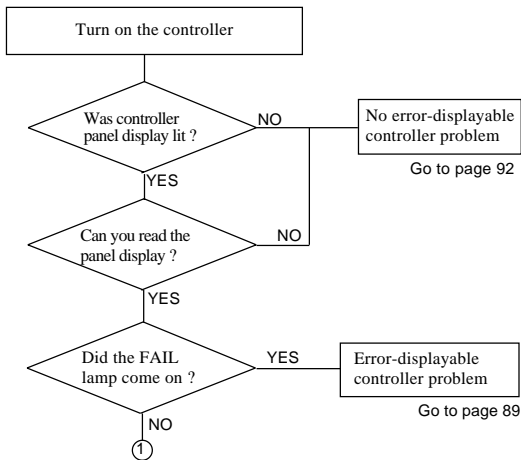

Continued on next page

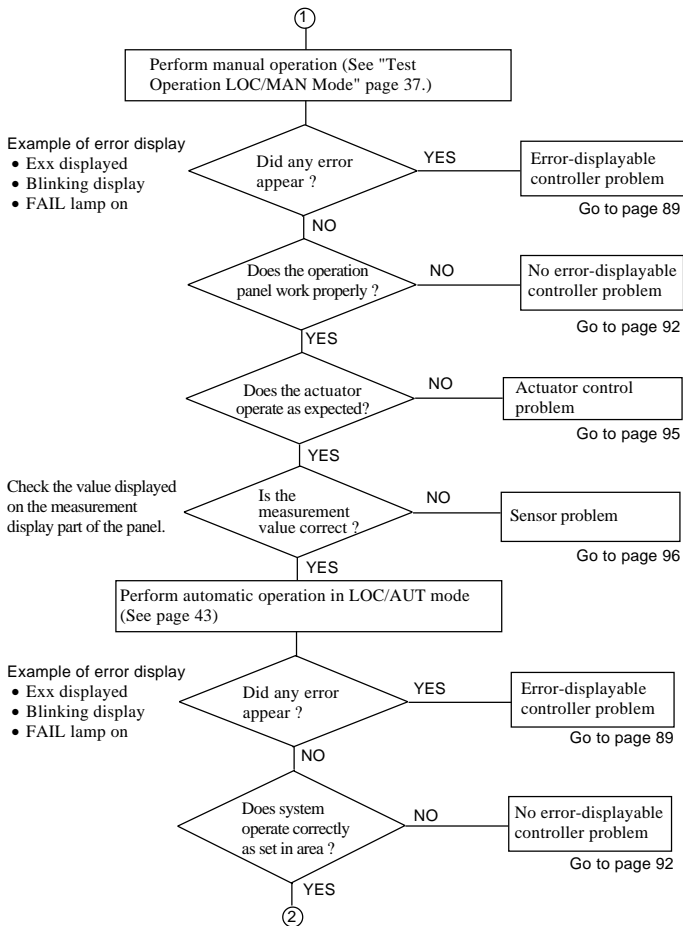

Continued on next page

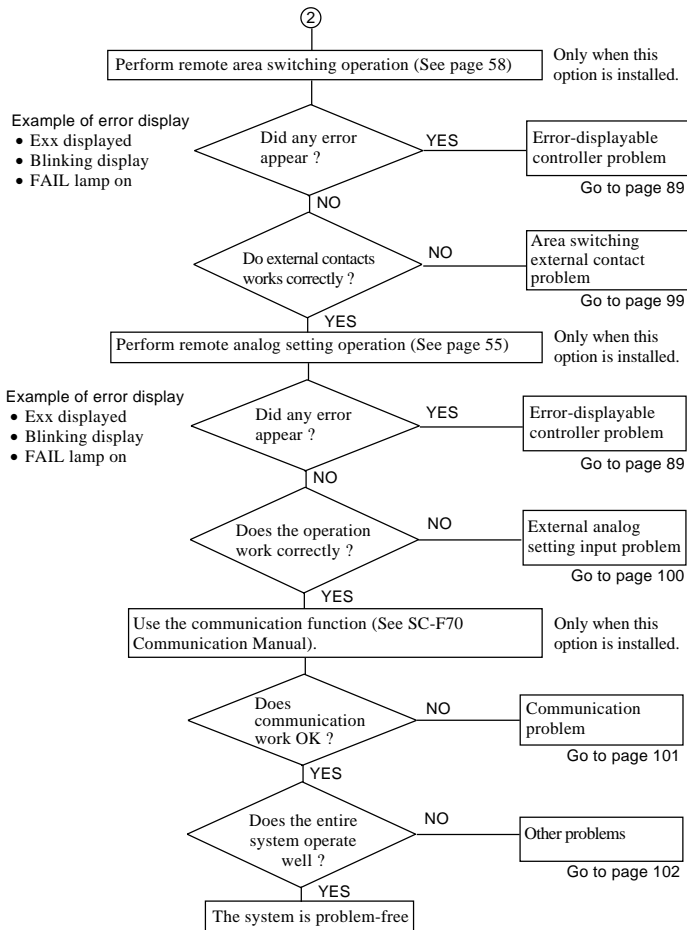

7.2 Error-Displayable Controller Problems

Check the error code and its displayed location, and take action.

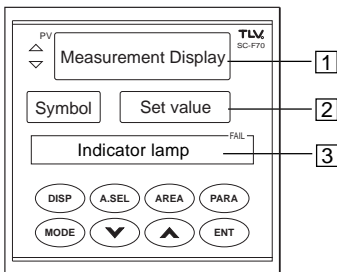

Error Code	Where	Error Description	Action
Measurement blinks	1	The sensor signal is 100% to 105% or -5 to 0% of the measurement range. Operation is not affected but blinking continues until the pressure comes inside the range.	1. Ensure the measurement input type is correct (See PG02 on page 69). 2. Go to "Sensor problem" on page 96.
0000 blinks		The sensor signal is above 105% of the measurement range. Recovery operation is defined by parameter PG08, item 1, and error code remains until the error has been corrected. (See parameter PG08 on page 78)	
UUUU blinks		The sensor signal is below -5% of the measurement range. Recovery operation is defined by parameter PG08, item 1, and error code remains until the error has been corrected. (See parameter PG08 on page 78)	
E04		The ambient temperature for the controller is more than 55°C (occurs only during thermocouple input). The error message is displayed until the error has been corrected; operation depends on the selection for what to do in the event of an input error.	Reinstall the equipment in a place where the ambient temperature is 0~50°C.
E05	The ambient temperature for the controller is less than -5°C (occurs only during thermocouple input). The error message is displayed until the error has been corrected; operation depends on the selection for what to do in the event of an input error.		

Error Code	Where	Error Description	Action
Analog input value blinks	2	The analog setting input signal is 100 to 105% or -5 to 0% of the input range. Operation is not affected but blinking continues until the error has been corrected.	<ol style="list-style-type: none"> 1. Ensure the analog input type is correct. (See PG05 on page 75) 2. Go to "External Analog Input Problems" on page 100.
0000 blinks		The analog setting input signal is above 105% of the input range. Recovery operation is defined by parameter PG08, item 1, and error code remains until the error has been corrected. (See parameter PG08 on page 78)	
UUUU blinks		The analog setting input signal is below -5% of the input range. Recovery operation is defined by parameter PG08, item 1, and error code remains until the error has been corrected. (See parameter PG08 on page 78)	
E08		No AREA number has been selected. Recovery operation is defined by parameter PG08, item 1, and error code remains until the error has been corrected. (See parameter PG08 on page 78)	<ol style="list-style-type: none"> 1. Check the value set by external contacts. 2. Go to "Area switching external contact problem" on page 99.
E09		An AREA number equal to or greater than 9 has been selected. Recovery operation is defined by parameter PG08, item 1, and error code remains until the error has been corrected. (See parameter PG08 on page 78)	
E11		An error occurs with the input value during Auto-tuning. The error message is displayed until the (DISP) is pressed; operation will follow the selection made for operation in the event of an Auto-tuning error (See parameter PG08 on page 78).	<p>If the same error occurs when Auto-tuning is executed again, set the PID constant manually. See "8. PID Constants Manual Tuning Method" on page 103.</p>
E12		The time for Auto-tuning execution has exceeded the allotted time (4 hours per cycle). The error message is displayed until the (DISP) is pressed; operation will follow the selection made for operation in the event of an Auto-tuning error (See parameter PG08 on page 78).	
E13	The PID constant derived through Auto-tuning exceeds the set range. The error message is displayed until the (DISP) is pressed; operation will follow the selection made for operation in the event of an Auto-tuning error (See parameter PG08 on page 78).		

Error Code	Where	Error Description	Action
E20	2	An attempt has been made to register a target setting outside the range of the setting limiter. The error code is displayed for 3 seconds, and then the controller reverts to the state before ENT was pressed.	Change the setting value or expand the limiter range.
E21		An attempt has been made to enter a value outside the setting input range. The error code is displayed for 3 seconds, and then the controller reverts to the state before ENT was pressed.	
E22		A key has been pressed when the present operation mode could not accept the entry. The error code is displayed for 3 seconds, and then the controller reverts to the status before ENT was pressed.	Change the control status and retry.
E30		AUT operation is occurring outside the range of the setting limiter. The error code is displayed until the error has been corrected. Operation is executed with the limiter value.	Re-enter a setting within the limiter range.
A11	1	RAM error has been detected. All other indicators turn off except the FAIL indicator and error code. All controller outputs are turned off.	Turn the controller off and on.
A12		Referenced input error has been detected. All other indicators turn off except the FAIL indicator and error code. All controller outputs are turned off.	If the error remains, have the controller serviced.
FAIL lights	3	ROM error or CPU power error or watchdog timer error occurred. All other indicators are turned off. All controller outputs are also turned off.	

7.3 No Error-Displayable Problems

This guide helps you analyze a problem when no error messages are displayed. Find your symptom in the left column, analyze it, and take action.

Display Symptom	Analysis	Action
No displays appear.	Make sure the correct line voltage is being applied.	Supply the correct line voltage.
	Make sure the power connection is to the proper terminals.	Connect the power to the terminals 1, 2, and 3.
Displays are abnormal.	Make sure that there is no noise source near the controller.	Move the noise source away from the controller.
	An analog setting input signal has been entered in parallel to multiple SC-F70 units using a grounded thermocouple.	Insert an isolator, etc. to ensure that an insulated analog setting signal is input to each unit.
Measured value displays differ from actual value.	Make sure the setting for measurement input range is correct.	Set the measurement input range by referring to the parameter PG02 on page 69.
	Check whether a measured input bias has been set.	Reset the bias to 0 (only if the measurement input bias can be changed) by referring to the parameter PG02 on page 69.
Analog setting input values differ from actual values.	Make sure that the analog setting input range is correct.	Set the analog setting input range correctly. See parameter PG05 on page 75.
	Make sure that a setting input bias has not been set.	Change the setting input bias to 0 (only if the setting input bias may be changed). See parameter PG05 on page 75.

Controller Symptom	Analysis	Action
Control is abnormal.	Check that input signal cables and the controller power cable or load cables are separated.	Separate the input signal cables from power cables or load cables.
	Check that there is no noise source near the controller.	Move the noise source away from the controller.
	Inappropriate PID constant.	Set the correct PID constant or execute Auto-tuning. See page 40, "Procedure-2 Setting the PID Constants with Auto-Tuning", or page 103, "PID Constants Manual Tuning Method".
	Check whether the two minus side (or two plus side) wires of the heating control output and the cooling control output are both connected to the actuator, in the heating, cooling PID operation.	Separate the two minus side (and two plus side) wires.
Even when Auto-tuning has been performed, the ideal PID constant is not obtained.	The characteristics of the equipment being controlled are not suited to the Auto-tuning process.	Set the PID constant manually. Refer to page 103 "8. PID Constants Manual Tuning Method".
	An output change rate limiter has been set.	Set the PID constant manually. Refer to page 103 "8. PID Constants Manual Tuning Method".
		Set the output change rate limiter to 0.0 (only if the output change rate limiter may be changed). Refer to PG03 on page 71.
The control output does not go above or below a certain value.	Check that an upper and lower output limiter have been set correctly.	Set the output upper or lower limiter appropriately when they can be changed, by referring to the area setting items on page 48.

Operating Panel Symptom	Analysis	Action
Setting cannot be changed with the controller keys.	Check whether or not a lock is set.	Change the setting data lock value to 0 by referring to the parameter PG10 on page 79.
Area selection cannot be made with the controller key.	Check whether operation mode is set to REM.	Change the operation mode to LOC by referring to "Mode Key Operation Flow" on page 25.
Area selection cannot be done through contact input.	The operation mode is set to local (LOC).	Change the operation mode to remote (REM) by referring to "Mode Key Operation Flow" on page 25.
Target value cannot be set above or below a certain value.	Check that proper setting limiter upper and lower limits have been set.	Change the setting limiters (only if this change is allowed) by referring to parameter PG10 on page 79.
When a new target setting value is entered, the new setting is not reflected immediately.	Check whether or not a soft start timer or setting rate limiter has been set.	Reset the soft start timer or setting change rate limiter to 0 by referring to the parameter PG10 on page 79 and the area setting value on page 48.
Other Symptom	Analysis	Action
Alarm operation is faulty.	Make sure the type of alarm, excitation, hysteresis setting, or alarm timer are selected correctly.	Reset these values to the ones you want by referring to "Using the Alarm" on page 64.

7.4 Actuator Control Problems

Use this guide when the actuator (for control valve, etc) does not perform as expected even though all panel operations are correct for manual operation.

Note: This section describes an example with a general-purpose control valve used as the actuator. If you are using a different actuator, contact TLV.

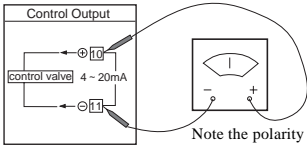
Analysis	Actions								
<p>Measure the controller output to the actuator while running test operation in MAN mode.</p> <p>Output Voltage in LOC/MAN</p> <table border="1" data-bbox="98 579 559 666"> <thead> <tr> <th>Control Output</th> <th>0%</th> <th>50%</th> <th>100%</th> </tr> </thead> <tbody> <tr> <td>Output Voltage</td> <td></td> <td></td> <td></td> </tr> </tbody> </table>  <p>Measure the voltage over terminals No.10 and 11 with a current and voltage meter.</p> <p>Note: Even if the output is in current mode, measure it in DC voltage.</p> <p>The output voltage changes proportionally with the target value settings.</p>	Control Output	0%	50%	100%	Output Voltage				<ul style="list-style-type: none"> When the voltages measured change proportionally: Control valve may be the cause of the problem. <p>See instruction manuals for the control valve to continue analysis.</p> <ul style="list-style-type: none"> When measurement shows about DC 0V, have the controller serviced. When measurement shows about DC 14V, the cable from the controller to the control valve is probably cut or disconnected; check cable and reconnect it.
Control Output	0%	50%	100%						
Output Voltage									

7.5 Sensor Problems

- When the measured values displayed are different from the actual sensor reading, use this analysis and action.

* This section describes an example with a pressure transmitter (MBS33M, from Danfoss A/S) and a temperature sensor (TR1) obtained from TLV. If you are using different equipment, contact TLV.

Analysis		Actions							
<p>• Using pressure transmitter (MBS33M)</p> <ol style="list-style-type: none"> Confirm that the pressure is correct using a pressure gauge. Confirm that PG02 parameters are set as follows. <ul style="list-style-type: none"> PVI : 701 PVL : Lower limit of pressure sensor range PVH : Upper limit of pressure sensor range PVF : 0 PVb : 0 Measure the sensor signal at the back panel by measuring the DC voltage between terminal 18 (+) and terminal 21 (-). 		<ul style="list-style-type: none"> If the parameter setting is not right, correct it. If the sensor signal is correct, the controller should be serviced. Contact TLV. If the measured voltage is over 5V, the pressure transmitter is damaged. Replace it. For other cases, go to the next step. 							
<div style="display: flex; align-items: flex-start;"> <div style="margin-right: 20px;"> </div> <div style="margin-right: 20px;"> </div> <div style="margin-right: 20px;"> <p>DC Voltage Range Note the polarity.</p> </div> <div> </div> </div> <table border="1" style="margin-top: 10px;"> <thead> <tr> <th>Secondary Pressure Value</th> <th>Measured Voltage (VDC)</th> </tr> </thead> <tbody> <tr> <td>Lower Limit</td> <td>1</td> </tr> <tr> <td>Upper Limit</td> <td>5</td> </tr> <tr> <td>Intermediate (PVH-PVL)÷2</td> <td>3</td> </tr> </tbody> </table> <p>The secondary pressure value is proportional to the measured voltage.</p>			Secondary Pressure Value	Measured Voltage (VDC)	Lower Limit	1	Upper Limit	5	Intermediate (PVH-PVL)÷2
Secondary Pressure Value	Measured Voltage (VDC)								
Lower Limit	1								
Upper Limit	5								
Intermediate (PVH-PVL)÷2	3								

Analysis	Actions								
<p>4. Measure the DC voltage between the \oplus terminal and the \ominus terminal of the pressure transmitter, and confirm that the voltage reading is about 19~23V.</p> <p>5. Remove the pressure transmitter from the measurement tube, and measure the sensor signal under atmospheric pressure.</p> <table border="1" data-bbox="108 720 487 870"> <thead> <tr> <th>Measurement Range of Pressure Sensor</th> <th>Sensor Output</th> </tr> </thead> <tbody> <tr> <td>0 ~ 2000 kPa G</td> <td>DC 1V</td> </tr> <tr> <td>0 ~ 500 kPa G</td> <td>DC 1V</td> </tr> <tr> <td>0 ~ 400 kPa abs</td> <td>DC 3V</td> </tr> </tbody> </table> <p>Take the actions in the right column depending on the measurement results.</p>	Measurement Range of Pressure Sensor	Sensor Output	0 ~ 2000 kPa G	DC 1V	0 ~ 500 kPa G	DC 1V	0 ~ 400 kPa abs	DC 3V	<ul style="list-style-type: none"> • If the voltage reading is about 0V, the wire between the controller and the pressure transmitter is broken. Repair the wiring. • If the voltage reading is about -19~-23V, the wires between the controller and the pressure transmitter are connected backward. Change the wiring for correct polarity. • For other cases, go to the next step. • If the measured value is adequate, clean the measurement tube to make sure there is no accumulation of dirt. • If the measured value is inadequate, replace the pressure transmitter or the wires to it. • If the measured value is not stable, check the signal wire shielding and the controller grounding.
Measurement Range of Pressure Sensor	Sensor Output								
0 ~ 2000 kPa G	DC 1V								
0 ~ 500 kPa G	DC 1V								
0 ~ 400 kPa abs	DC 3V								

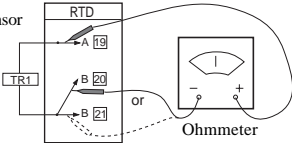
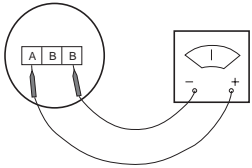
Analysis	Action
<p>• Using temperature sensor (TR1)</p> <ol style="list-style-type: none"> 1. Reconfirm that the temperature value indicated on the thermometer is correct. 2. Confirm that the settings for the sensor in the parameter PG02: PVI : 410 PVF : 0 PVb : 0 3. Meter the sensor resistance between wire No.19 and 20 or 21, after detaching them from the terminals. * The TR1 resistance value is affected by the ambient temperature. To know the correct resistance for a given condition, refer to the document that has the Pt100 standardized resistance values.  <ol style="list-style-type: none"> 4. Remove the sensor cables from the sensor terminal, and measure the sensor resistance between A and B as shown. 	<ul style="list-style-type: none"> • If the setting is not right, correct it. • If the resistance is adequate, have the controller serviced. • If the resistance reading differs largely from standard resistance, have the sensor serviced. • If the reading is zero Ω or infinity, go to the next step. • If the resistance is adequate, have the sensor cable serviced. If the resistance is not adequate, replace the sensor.

7.6 Area Switching External Contact Problems

When an area switching operation works correctly in LOC mode but not in REM mode using external contacts, refer to this guide.

Analysis	Action				
<p>1. Ensure your controller is equipped with the remote area switching feature.</p> <p>Model code = SC-F70- □ *D □</p> <p>The second-to-last digit should be a D.</p> <p>2. Check that the setting in item 1 of the parameter PG06 is correct. See page 76.</p> <p>3. Measure the voltages of the contacts on the back panel terminals.</p> <div data-bbox="85 678 314 992" style="border: 1px solid black; padding: 5px; margin: 10px 0;"> <p>The diagram shows a vertical terminal block with five terminals. From top to bottom: Di1 (12), COM (-) (13), Di2 (14), Di3 (15), and Di4 (16). Each terminal has a small circle above it representing a contact point. Arrows point from the contact points to the terminal labels.</p> </div> <table border="1" data-bbox="325 720 617 848" style="margin: 10px 0;"> <tbody> <tr> <td>Contact open</td> <td>About DC 5V or higher</td> </tr> <tr> <td>Contact closed</td> <td>About DC 2V or lower</td> </tr> </tbody> </table> <p>Measure between the common and Di1 to Di4 while opening or closing each contact point.</p>	Contact open	About DC 5V or higher	Contact closed	About DC 2V or lower	<ul style="list-style-type: none"> • If the code is different, this function cannot be used. • If the setting is incorrect, correct it. • If the measured voltages for all points are correct, have the controller serviced. • If any measured voltages are incorrect, have the external contacts or cables serviced.
Contact open	About DC 5V or higher				
Contact closed	About DC 2V or lower				

7.7 External Analog Input Problems

When operation is correct in LOC mode, but analog input operation does not work in REM mode using external analog input, refer to this guide.

Analysis	Action																
<p>1. Ensure your controller is equipped with the remote analog input feature.</p> <p>Model code = SC-F70- <input type="checkbox"/> *A <input type="checkbox"/></p> <p>The second-to-last digit should be an A.</p> <p>2. Check that the settings in all items of the parameter PG05 and PG06 are correct. See page 75 and 76.</p> <p>3. Measure the voltages of the contacts on the back panel terminals.</p> <div data-bbox="80 618 308 982" style="border: 1px solid black; padding: 5px;"> </div> <table border="1" data-bbox="319 647 614 728"> <tr> <td>Contact open</td> <td>More than DC 5V</td> </tr> <tr> <td>Contact closed</td> <td>Less than DC 2V</td> </tr> </table> <table border="1" data-bbox="319 742 614 1026"> <thead> <tr> <th>Type</th> <th>Voltage</th> </tr> </thead> <tbody> <tr> <td>For DC 0 - 5V</td> <td>DC 0 - 5V</td> </tr> <tr> <td>For DC 1 - 5V</td> <td>DC 1 - 5V</td> </tr> <tr> <td>For DC 0 - 10V</td> <td>DC 0 - 10V</td> </tr> <tr> <td>For 4 - 20mA</td> <td>DC 1 - 5V</td> </tr> <tr> <td>For 0 - 20mA</td> <td>DC 0 - 5V</td> </tr> </tbody> </table> <p>Instructions:</p> <ol style="list-style-type: none"> 1. Measure between COM and Di1 while opening or closing the contact point. 2. Measure the voltage between terminal 15 and 16 while varying the analog value. For analog input in DC current, measure it in DC voltage range. 	Contact open	More than DC 5V	Contact closed	Less than DC 2V	Type	Voltage	For DC 0 - 5V	DC 0 - 5V	For DC 1 - 5V	DC 1 - 5V	For DC 0 - 10V	DC 0 - 10V	For 4 - 20mA	DC 1 - 5V	For 0 - 20mA	DC 0 - 5V	<ul style="list-style-type: none"> • If the code is different, this function cannot be used. • If the settings are incorrect, correct them. • If the measured voltages for the point and the analog input are adequate, have the controller serviced. • If any measured voltages are inadequate, have the external analog input device or cables serviced.
Contact open	More than DC 5V																
Contact closed	Less than DC 2V																
Type	Voltage																
For DC 0 - 5V	DC 0 - 5V																
For DC 1 - 5V	DC 1 - 5V																
For DC 0 - 10V	DC 0 - 10V																
For 4 - 20mA	DC 1 - 5V																
For 0 - 20mA	DC 0 - 5V																

7.8 Communication Problems

When all operations in all modes work correctly but a communications function fails, use this guide.

Analysis	Action
<p>1. Confirm that there is no problem other than a communications problem.</p> <p>2. Ensure that your controller is equipped with the communication functions.</p> <div style="border: 1px solid black; padding: 5px; margin: 10px 0;"> Model code = SC-F70- <input type="checkbox"/>*<input type="checkbox"/> 1 (RS-232C) SC-F70- <input type="checkbox"/>*<input type="checkbox"/> 4 (RS-422A) SC-F70- <input type="checkbox"/>*<input type="checkbox"/> 5 (RS-485) </div> <p>The last digit should be either 1, 4, or 5.</p> <p>3. Check that the settings in all items of the parameter PG12 are correct. See page 80.</p>	<ul style="list-style-type: none"> • If problems exist without using communication function, analyze those problems first. • If the code is different, this function cannot be used. <ul style="list-style-type: none"> • If incorrect settings are found, correct them first, and try again. • If the settings are correct, continue analysis by referring to the "SC-F70 Communications Operating Instructions" manual.

7.9 Other Problems

This guide covers problems that are not mentioned in the preceding guides. One type is unstable measurement/analog setting value problems.

The other type is for problems with drifting, overshooting, or undershooting pressure problems.

Unstable measurement/analog setting value problems

Analysis	Action
1. Check that wiring is done properly for the sensor signal cable and control output signal cable, including their shield wires and their grounding. See "1.4 Wiring Procedure " on page 11 for precautions.	<ul style="list-style-type: none"> • If any flaws are found, correct them.
2. If an external analog input device is used, the signal fluctuation must be as follows: At the source: $\pm 0.1\%$ F.S. or less	<ul style="list-style-type: none"> • If more than 0.1% is observed, you must reduce fluctuation below the specification at the contact source points.
3. Check that there is no electrical noise at the installation place, or drifting or spikes in the AC power source.	<ul style="list-style-type: none"> • If any noise is observed, take the appropriate measures to remove the source of the interference.
4. Observe any changes in fluctuation as you remove the transmission output cables, the external input contact cable, the alarm cables, and communication line cables, one-by-one.	<ul style="list-style-type: none"> • If the symptom changes as a certain cable is disconnected, make a further check of the cable.

Overshooting/Undershooting, or unstable secondary pressure problems when target value is changed

Analysis	Actions
1. Confirm that the conditions under which the actuator is used are within the product specifications.	<ul style="list-style-type: none"> • If the control system is used outside of the product specifications, unpredictable problems can occur. Use the system within the specifications.
2. Check that the Cr is not set to 2 (fast). Refer to "3.5 Compensation for Control Responsiveness" on page 51.	<ul style="list-style-type: none"> • Reset Cr to 0 (slow).
3. Change the PID constants by referring to "3.6 PID Constants Fine Tuning Method" on page 52, and observe whether the symptom improves.	<ul style="list-style-type: none"> • If the symptom does not recur, leave the new setting and continue monitoring.

8. PID Constants Manual Tuning Method

Among various Auto-tuning or manual method for determining proper PID constants, this section introduces two manual methods. The manual methods are effective when Auto-tuning does not provide the proper values.

If you still cannot obtain satisfactory control results even if you use the methods described here, refer to "3.6 PID Constants Fine Tuning Method" on page 52.

8.1 Step Response Method

In this method, you change the control output values in steps, and you measure and analyze a value for each step to attain the best PID values. You need a recorder to trace the measured value change. This method is done in MAN/LOC mode.

1. Set the controller in the MAN/LOC mode. See page 25.
2. Adjust the control output with the \wedge or \vee key until the measured value almost reaches the target setting value.
3. Wait until the value stabilizes a little below the target measurement value.
4. Start a recorder to record the variation of the measured value.
5. Quickly increase the control output 5 to 15% over the value set in step 3. Write the variance (DMV) of this increase.
6. The recorder should show a graph like that shown at the lower right. Draw a tangent crossing the inflection point of the S curve. The intersection point of the tangent and old equilibrium value gives L and T (sec).
7. Specify the value variation as DPV, and define the process gain K_p using the following equation:

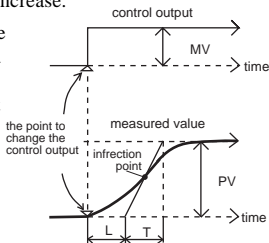

$$K_p = \frac{DPV}{(\text{Measurement range})} \times 100 \times \frac{1}{DMV}$$

8. Seek the PID constants using the following equations:

Proportional band $P=167\%K_p\%L/T$

Integral time $I=T$

Differential time $D=0.5L$

9. Entering the PID values determined in the previous step, run the controller in AUT mode and verify its control responsiveness.

Note: If the results do not meet your requirements, change the PID values by referring to "3.6 PID Constants Fine Tuning Method" on page 52.

8.2 Ultimate Sensitivity Method

In this method (also called Ziegler Nichols method), determine the PID constants by analyzing the oscillation waveforms of the measurement value. You need a recorder to get a picture of the oscillation behavior. This method is done in AUT/LOC mode.

1. Set the controller in the AUT/LOC mode. See page 25.
2. Set both the integral time (I) and the differential time (d) to 0 seconds. See page 23.
3. Set the proportional band (P) to a large value. See page 23.
4. Set the target setting and measure the value.
5. After the measurement value stabilizes, decrease the P value, and then change the target setting value.

6. Decrease the P value until the measurement value oscillates with a constant amplitude.
7. Specify the P value at this point as P_{Bu} (%), and the cycle time of the oscillation as P_u (sec).

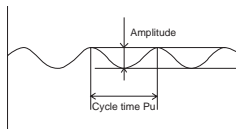

8. Determine the PID constants using the following equations:

$$\text{Proportional band} \quad P=1.7\%P_{Bu}$$

$$\text{Integral time} \quad I=0.5\%P_u$$

$$\text{Differential time} \quad d=0.125\%P_u$$

9. Entering the PID values determined in the previous step, run the controller in AUT mode and verify its control responsiveness.

Note: If the results do not meet your requirements, change the PID values by referring to "3.6 PID Constants Fine Tuning Method" on page 52.

9. Specifications

This chapter provides product specifications for pressure control.

9.1 Display Functions

- | | |
|----------------------------------|--------------------------------|
| (1) Measured value (PV) display: | 4-digit 7-segment LED (orange) |
| (2) Set value (SV) display: | 4-digit 7-segment LED (orange) |
| (3) Symbol display: | 3-digit 7-segment LED (orange) |
| (4) Operation LED: | |
| 1 SFT (Soft start control): | surface-emitting LED (green) |
| 2 AUT (Auto mode): | surface-emitting LED (green) |
| 3 REM (Remote mode): | surface-emitting LED (green) |
| 4 AT (Auto-tuning): | surface-emitting LED (orange) |
| 5 AL1-AL4 (Alarms): | surface-emitting LED (red) |
| 6 FAIL (Fail status): | surface-emitting LED (red) |
| 7 UP (Up deviation): | surface-emitting LED (orange) |
| 8 DOWN (Down deviation): | surface-emitting LED (green) |

9.2 Measurement Input

(1) Types

- | | |
|------------------------------|--------------------------|
| 1. Thermocouple input | |
| Input values: | K, J, E, T, U, L |
| Signal source resistance: | Approximately 0.2mV/W |
| Input impedance: | 1MΩmin. |
| 2. RTD input | |
| Input values: | Pt100, JPt100 |
| Sensor current: | Approximately 0.25mA |
| Input line resistance range: | 10Wmax. |
| 3. DC voltage (LOW) input | |
| Input values: | 0-10 mV, 0-100 mV, 0-1 V |
| Input impedance: | Approximately 1 MΩ |
| Input voltage range: | Within ± 4 V |
| 4. DC voltage (HIGH) input | |
| Input values: | 0-5 V, 1-5 V, 0-10 V |
| Input impedance: | Approximately 1 MΩ |
| Input voltage range: | Within ± 12 V |

5. DC current input
 Input values: 0-20 mA, 4-20 mA
 Input impedance: Approximately 250W
- (2) Measurement accuracy: \pm (0.1%F.S. + 1 digit)
- (3) Sampling period: 0.25 second
- (4) Measurement Input Bias: \pm (5% of measurement span)
- (5) PV Digital Filter: Primary delay filter 0-100 seconds (variable)
 Note: when set to 0, PV Digital Filter is OFF.

9.3 Settings

- (1) Setting range (SV): Same as measurement range
- (2) Setting resolution: Depending on measurement input range
- (3) Setting limiters (upper/lower): Arbitrary value within measurement input range
- (4) Soft start time: 0.00 to 99.59
 Note: Unit selectable (hour.minute or minute.second)
- (5) Setting change rate limiter: 0.0 to measurement span %/minute
 Note: When set to 0.0, the setting change rate limiter is OFF.
- (6) AREA function
- Number of AREAs: 8
- AREA switching method: * Using keys on front panel
 * Through external contacts when model is equipped with area switching external input feature
 * Through communications when model is equipped with communication feature

(7) Analog setting input on models equipped with analog setting input feature

1. Input values

- | | |
|----------------------|----------------------|
| a. DC voltage input: | 0-5 V, 1-5 V, 0-10 V |
| Input impedance: | Approximately 1 MW |
| b. DC current input: | 0-20 mA, 4-20 mA |
| Input impedance: | Approximately 250W |

Note: Input type a or b can be selected with a jumper.

- | | |
|-----------------------------|---|
| 2. Sampling period: | 0.5 second |
| 3. Input accuracy: | \pm (0.1% F.S. of input span + 1 digit) |
| 4. Input compensation bias: | \pm (5% of input span) |
| 5. Range setting: | Same as measurement input range |
| 6. Input digital filter: | Primary delay filter 0-100 seconds (variable) |
| | Note: Filter is OFF when set to 0. |
| 7. Allowable input voltage: | Within \pm 12 V |

9.4 Control Operation

(1) Types of control operation

1. Auto-tuning PID operation
2. Heating, cooling PID operation

(2) Control calculation period: 0.25 second

9.5 Control Output

9.5.1 First Control Output (OUT1)

This is the control output in the Auto-tuning PID operation, and the heating control output in the heating, cooling PID operation.

DC current output

- | | |
|---------------------------|----------------|
| 1. Output: | 4-20 mA |
| 2. Load resistance range: | 600W maximum |
| 3. Output impedance: | 5 MW minimum |
| 4. Output accuracy: | ± 0.1% of span |
| 5. Output resolution: | 11 bit minimum |

* When a relay output is selected for the first control output type, the first control output becomes the transmission output 3.

Relay output

- | | |
|-------------------------|-------------------------------------|
| 1. Contact: | 1c contact |
| 2. Output: | AC250V 3A (resistor load) |
| 3. Electric life: | More than 300,000 times(rated load) |
| 4. Proportional period: | 1~100 seconds, variable |

* When a current output is selected for the first control output type, the first control output becomes the alarm output 3 (AL3).

*** Either the DC current output or the relay output can be specified as the first control output type.**

9.5.2 Second Control Output (OUT2)

This is the cooling control output in the heating, cooling PID operation. This output becomes the transmission output 2 or the alarm output 4 (AL4), respectively, in Auto-tuning PID operation.

DC current output

- | | |
|---------------------------|----------------|
| 1. Output: | 4-20 mA |
| 2. Load resistance range: | 600W maximum |
| 3. Output impedance: | 5 MW minimum |
| 4. Output accuracy: | ± 0.1% of span |
| 5. Output resolution: | 11 bit minimum |

* When a relay output is selected for the second control output type, the second control output becomes the transmission output 2.

Relay output

- | | |
|-------------------------|-------------------------------------|
| 1. Contact: | 1a contact |
| 2. Output: | AC250V 3A (resistor load) |
| 3. Electric life: | More than 300,000 times(rated load) |
| 4. Proportional period: | 1~100 seconds, variable |

* When a current output is selected for the second control output type, the second control output becomes the alarm output 4 (AL4).

*** Either the DC current output or the relay output can be specified as the second control output type.**

9.6 Alarm Output

- (1) Number of alarm points: 4 points maximum
 *The number of alarm points decreases, if the control output is a relay output.
- (2) Alarm types: Alarm suppressed, measurement upper limit, measurement lower limit, deviation upper limit, deviation lower limit, deviation upper/lower limits, within deviation range, measurement upper limit with standby, measurement lower limit with standby, deviation upper limit with standby, deviation lower limit with standby, deviation upper/lower limit with standby, input error, FAIL status
 Note: Selectable with alarm settings
- (3) Setting range
 1. Measurement alarms: Same as measurement input range
 2. Deviation alarms: 0 to measurement span or 0 to 9999
 Note: Unit/decimal point position is the same as for measurement input.
- (4) Operation hysteresis: 0 to 10% of measurement span
- (5) Alarm timer: 0 to 600 seconds for each alarm
- (6) Exciting/Non-exciting: Selectable
 Note: The FAIL alarm acts on non-exciting settings only, opening the relay contact in FAIL status and closing it in normal status.
- (7) Output
 1. Relay contact output: 1a contact
 (1c contact for AL3 output)
2. Rating
 1) AL1 and AL2: AC 250 volts, 1 ampere with resistance load
 2) AL3 and AL4: AC 250 volts, 3 amperes with resistance load
3. Electrical service life
 1) AL1 and AL2: 50,000 times minimum under rated load
 2) AL3 and AL4: 300,000 times minimum under rated load
- (8) Alarm display: Red surface-emitting LED (AL1 to AL4)

9.7 Transmission Output

- | | |
|----------------------------------|---|
| (1) Number of output points: | 3 points maximum
*The number of transmission output points decreases, if the control output is a current output. |
| (2) Output types (selectable): | Measured value, set value, deviation, or control output |
| (3) Output signal: | DC 4 mA to 20 mA |
| (4) Load resistance: | 600W maximum |
| (5) Output scaling setting range | |
| 1. Measurement value (PV): | Same as measurement input range |
| 2. Deviation (DEV): | ±measurement span or -1999 to 9999 |
| 3. Set value (SV): | The same as for the measurement input range |
| | Note: Decimal point position is the same as for the measurement range, for 1, 2, and 3. |
| 4. Control output (OUT): | 0.0 to 100.0% |
| (6) Output accuracy: | ±0.1% of span |
| (7) Output resolution: | 11 bits minimum |

9.8 External Contact Input

- | | |
|---|--|
| (1) When external analog setting input function is installed: | |
| 1. Number of input points: | 1 |
| 2. Input method used: | No-voltage type contact |
| Resistance when OPEN: | 500 kW minimum |
| Resistance when CLOSED: | 10W maximum |
| 3. Voltage when OPEN: | DC 5 V |
| 4. Functions (selectable): | Operation mode switching, MAN/AUT or LOC/REM |

- (2) When external AREA selection contact input is installed:
1. Number of input points: 4
 2. Input method used: No-voltage type contact
 - Resistance when OPEN: 500 kW minimum
 - Resistance when CLOSED: 10W maximum
 3. Voltage when OPEN: DC 5 V
 4. Functions (selectable)
 - a. MAN/AUT selection + area selection
 - b. LOC/REM selection + area selection
 - c. Area selection

9.9 Communication Output

- (1) Specifications
1. Communication interface (specify type at time of order)
 - a. Conforms to EIA RS-422A
 - b. Conforms to EIA RS-485
 - c. Conforms to EIA RS-232C
 2. Protocol: Conforms to ANSI X3.28 sub-category 2.5 A4
- (2) Communication line
1. RS-422A: 4-wire, multidrop
 2. RS-485: 2-wire, multidrop
 3. RS-232C: 3-wire, point-to-point
- (3) Communication distance
1. RS-422A: 1 km (3281 ft) maximum
 2. RS-485: 1 km (3281 ft) maximum
 3. RS-232C: 15 m (49 ft) maximum
- Note: These values may differ slightly depending on cables and other factors in the surrounding environment.
- (4) Synchronization: Start-stop synchronization
- (5) Communication speed: 1200 bps, 2400 bps, 4800 bps, 9600 bps, or 19200 bps
- (6) Data format
1. Start bit: 1

2. Data bit: 7 or 8
 3. Parity bit: None or Yes (odd or even)
 4. Stop bit: 1 or 2

(7) Maximum unit connection

1. RS-422A: 32 units including host computer

Note: Depending on host computer driver capability, the maximum number might not be supported.

2. RS-485: 32 units including host computer
 3. RS-232C: 1 unit

(8) Communication code: ASCII (JIS) 7-bit code

(9) Terminals

1. RS-422A, 4-wire

Terminal No.	Signal	SC-F70 <Signal Direction> Host	Remarks
33	R(A)		Receive data
34	R(B)		Receive data
35	T(A)		Transmit data
36	T(B)		Transmit data
37	SG		Signal ground

2. RS-485, 2-wire

Terminal No.	Signal	SC-F70 <Signal Direction> Host	Remarks
35	T/R(A)		Transmit/receive data
36	T/R(B)		Transmit/receive data
37	SG		Signal ground

3. RS-232C, 3-wire

Terminal No.	Signal	SC-F70 <Signal Direction> Host	Remarks
35	SD		Transmit data
36	RD		Receive data
37	SG		Signal ground

(10) Signal logic

1. RS-422A and RS-485

Signal Voltage	Logic
$V(A) > (B)$	0 (space)
$V(A) < (B)$	1 (mark)

2. RS-232C

Signal Voltage	Logic
+ 3 V or more	0 (space)
- 3 V or less	1 (mark)

(11) Bit configuration

(The example shows 1 start bit, 7 data bits, 1 parity bit, and 2 stop bits.)

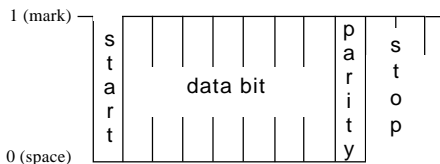

9.10 Self-Diagnostic Function

(1) Check items:

1. ROM/RAM check
2. Input value check
3. CPU power monitoring
4. Watchdog timer

(2) Error display:

1. FAIL lamp lights for CPU error
[(1) 1,3,4 above]
2. Error codes for input error
[(1) 2]

(3) Output in the event of error

1. When the FAIL lamp lights: All output is turned OFF

Note: The alarm function can be used to detect the FAIL condition.

2. When an input error occurs: Depends on the operation selection in the event of an input error

9.11 General Specifications

- | | |
|-----------------------------|--|
| (1) Insulation resistance: | DC 500 V, 20 MW minimum between measurement terminals and ground terminals
DC 500 V, 20 MW minimum between power terminals and ground terminals |
| (2) Dielectric strength: | AC 1000 V for one minute between measurement terminals and ground terminals
AC 1500 V for one minute between power terminals and ground terminals |
| (3) Line voltage: | AC 90 V to AC 264 V including line voltage fluctuations, 50/60 Hz, rated AC 100V to AC 240 V |
| (4) Power consumption: | 13 VA at AC 240V
10 VA at AC 100V |
| (5) Effect of power outage: | No effect on operation if power outage is 50 msec. or less |
| (6) Warm-up time: | 1 hour |
| (7) Memory backup: | Data is backed up by a lithium battery.
Battery service life: Approximately 10 years, depends on product storage time, storage environment, usage, and other conditions |
| (8) Weight: | Approximately 500 g (1.1 lb) |
| (9) Accessories: | A pair of mounting brackets |

9.12 Environmental Conditions (Normal Operation)

- | | |
|--------------------------|-------------------------|
| (1) Ambient temperature: | 0 to 50°C (32 to 122°F) |
|--------------------------|-------------------------|

(2) Ambient humidity:	20% to 80% RH
(3) Atmosphere:	No corrosive gases and no excessive dust
(4) Line voltage:	Within rated value \pm 10%
(5) Power frequency:	Within rated value \pm 5%
(6) Magnetic field:	400 AT/meter maximum
(7) Warm-up time:	1 hour minimum

9.13 Shipping and Storage Conditions

(1) Temperature:	-20 to 70°C (-4 to 158°F)
(2) Humidity:	95% RH maximum, no dew
(3) Vibration:	5 m/sec ² (16.4 ft/sec ²)
(4) Shock:	100 m/sec ² (328 ft/sec ²)

10. Product Warranty

1. **Warranty Period**
One year following product delivery.
2. **Warranty Coverage**
TLV Co., Ltd. warrants this product to the original purchaser to be free from defective materials and workmanship. Under this warranty the product will be repaired or replaced, at our option, without charge for parts or labor.
3. This product warranty will not apply to appearance items nor to any product whose exterior has been damaged or defaced, nor does it apply in the following cases:
 1. Malfunctions due to improper installation, use, handling, etc., by other than TLV Co., Ltd., authorized service representatives.
 2. Malfunctions due to dirt, scale, or rust, etc.
 3. Malfunctions due to improper disassembly and reassembly, or inadequate inspection and maintenance by other than TLV Co., Ltd., authorized service representatives.
 4. Malfunctions due to disasters or forces of nature.
 5. Accidents or malfunctions due to any other cause beyond the control of TLV Co., Ltd.
4. Under no circumstances will TLV Co., Ltd. be liable for consequential economic damage or consequential damage to property.

For Service or Technical Assistance:

Contact your TLV® representative or your regional TLV® office listed on the next page.

TLV INTERNATIONAL, INC.

881 Nagasuna, Noguchi,
Kakogawa, Hyogo 675, Japan
Tel: [81]-(0)794-27-1818 Fax: [81]-(0)794-25-7033

Manufacturer

TLV CO., LTD.

881 Nagasuna, Noguchi, Kakogawa, Hyogo 675, Japan
Tel: [81]-(0)794-22-1122 Fax: [81]-(0)794-22-0112
Home Page:<http://www.tlv.com>

For Service or Technical Assistance:

Contact your **TLV** representative or your regional **TLV** office

In North America:

TLV CORPORATION

13901 South Lakes Drive
Charlotte, NC 28273-6790 U.S.A.
Tel: [1]-704-597-9070 Fax: [1]-704-583-1610

In Europe:

TLV EURO ENGINEERING GmbH

Main Office
Dimler-Benz-Strassen 16-18
74915 Waibstadt, Germany
Tel: [49]-(0)7263-9150-0 Fax: [49]-(0)7263-9150-50

U.K. Office

Priory Lodge, London Road,
Cheltenham, Gloucestershire GL52 6HQ U.K.
Tel: [44]-(0)1242-221180 Fax: [44]-(0)1242-221055

In Southeast Asia:

TLV EAST ASIA PTE LTD

66 Tannery Lane,
#03-10B Sindo Building, Singapore 347805
Tel: [65]-7474600 Fax: [65]-7420345

TLV®

TLV® CO., LTD.