



Manufacturer

**TLV** CO., LTD.

Kakogawa, Japan

is approved by LRQA LTD. to ISO 9001/14001



# Instruction Manual

Free Float Steam Trap

**JH7.2R-P**

(Optional Models)

**JH7.2R-W / JH7.2R-F / JH7.2R-V**

Copyright © 2015 by TLV CO., LTD.

All rights reserved

## Contents

Introduction .....	1
Safety Considerations .....	2
Checking the Piping .....	4
Operation .....	5
Specifications .....	6
Configuration .....	6
Installation .....	7
Maintenance .....	8
Disassembly / Reassembly .....	9
Instructions for Plug / Holder Disassembly and Reassembly	12
Troubleshooting .....	13
Product Warranty .....	14
Options .....	15

## Introduction

Thank you for purchasing the **TLV** Free Float Steam Trap.

This product has been thoroughly inspected before being shipped from the factory. When the product is delivered, before doing anything else, check the specifications and external appearance to make sure nothing is out of the ordinary. Also be sure to read this manual carefully before use and follow the instructions to be sure of using the product properly.

This instruction manual is edited based on the JH-P Series (with cover plug). The JH-W Series (with socket welded cover connection), JH-F Series (with flanged cover connection) and JH-V Series (with manual air vent valve) are described at the end of this manual in the 'Option' section.

This free float steam trap employs a hinge-less and lever-less free float to rapidly, automatically and continuously discharge the inflowing condensate that is continuously generated inside the equipment, thus preventing the accumulation of condensate and thereby improving the heat transfer efficiency of the equipment.

This free float steam trap is suitable for process systems and steam-using equipment under long continuous operation with the introduction of almost no air.







If detailed instructions for special order specifications or options not contained in this manual are required, please contact **TLV** for full details.

This instruction manual is intended for use with the model(s) listed on the front cover. It is necessary not only for installation but for subsequent maintenance, disassembly/reassembly and troubleshooting. Please keep it in a safe place for future reference.

## Safety Considerations

- Read this section carefully before use and be sure to follow the instructions.
- Installation, inspection, maintenance, repairs, disassembly, adjustment and valve opening/closing should be carried out only by trained maintenance personnel.
- The precautions listed in this manual are designed to ensure safety and prevent equipment damage and personal injury. For situations that may occur as a result of erroneous handling, three different types of cautionary items are used to indicate the degree of urgency and the scale of potential damage and danger: DANGER, WARNING and CAUTION.
- The three types of cautionary items above are very important for safety: be sure to observe all of them as they relate to installation, use, maintenance, and repair. Furthermore, TLV accepts no responsibility for any accidents or damage occurring as a result of failure to observe these precautions.

### Symbols

	Indicates a <b>DANGER, WARNING or CAUTION</b> item.
	Indicates an urgent situation which poses a threat of death or serious injury
	Indicates that there is a potential threat of death or serious injury
	Indicates that there is a possibility of injury or equipment / product damage
	<b>NEVER apply direct heat to the float.</b> The float may explode due to increased internal pressure, causing accidents leading to serious injury or damage to property and equipment.
	<b>Install properly and DO NOT use this product outside the recommended operating pressure, temperature and other specification ranges.</b> Improper use may result in such hazards as damage to the product or malfunctions that may lead to serious accidents. Local regulations may restrict the use of this product to below the conditions quoted.
	<b>DO NOT use this product in excess of the maximum operating pressure differential.</b> Such use could make discharge impossible (blocked).
	<b>Use hoisting equipment for heavy objects (weighing approximately 20 kg (44 lb) or more).</b> Failure to do so may result in back strain or other injury if the object should fall.
	<b>Take measures to prevent people from coming into direct contact with product outlets.</b> Failure to do so may result in burns or other injury from the discharge of fluids.

Safety considerations continued on next page.

 <b>CAUTION</b>	<p><b>When disassembling or removing the product, wait until the internal pressure equals atmospheric pressure and the surface of the product has cooled to room temperature.</b> Disassembling or removing the product when it is hot or under pressure may lead to discharge of fluids, causing burns, other injuries or damage.</p>
	<p><b>Be sure to use only the recommended components when repairing the product, and NEVER attempt to modify the product in any way.</b> Failure to observe these precautions may result in damage to the product and burns or other injury due to malfunction or the discharge of fluids.</p>
	<p><b>Use only under conditions in which no freeze-up will occur.</b> Freezing may damage the product, leading to fluid discharge, which may cause burns or other injury.</p>
	<p><b>Use only under conditions in which no water hammer will occur.</b> The impact of water hammer may damage the product, leading to fluid discharge, which may cause burns or other injury.</p>

## Checking the Piping



Use only under conditions in which no water hammer will occur. The impact of water hammer may damage the product, leading to fluid discharge, which may cause burns or other injury.

Check to make sure that the pipes to be connected to the trap have been installed properly.

1. Is the pipe diameter suitable?
2. Is the piping where the trap is to be installed horizontal?
3. Has sufficient space been secured for maintenance?
4. Have isolation valves been installed at the inlet and outlet? If the outlet is subject to back pressure, has a check valve (TLV-CK) been installed?
5. Is a bypass valve installed?
6. Is the inlet pipe as short as possible, with as few bends as possible, and installed so the liquid will flow naturally down into the trap?
7. Has the piping work been done correctly, as shown in the figures below?

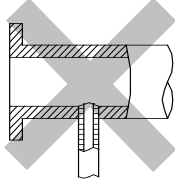
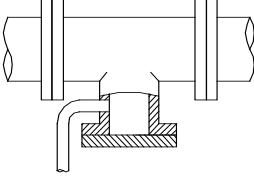
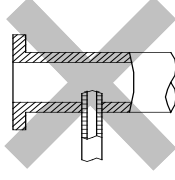
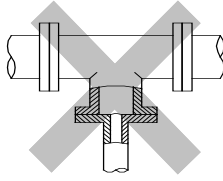
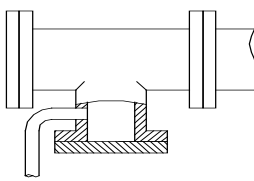
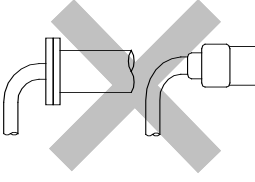
Requirement	Correct	Incorrect
Install catchpot with the proper diameter.		 <p>Diameter is too small.</p>
Make sure the flow of condensate is not obstructed.		 <p>Diameter is too small and inlet protrudes into pipe interior.</p>
To prevent rust and scale from flowing into the trap, the inlet pipe should be connected 25 – 50 mm (1 – 2 in) above the base of the T-pipe.		 <p>Rust and scale flow into the trap with the condensate.</p>
When installing on the blind end, make sure the flow of condensate is not obstructed.		 <p>Condensate collects in the pipe.</p>

## Operation

Principles of condensate discharge:

As much air as possible should be eliminated at start-up using a bypass valve or blowdown line.

### 1. Condensate Discharge

As steam is supplied, condensate flow begins. The rising condensate level causes the float to rise due to buoyancy, opening the orifice (A) and allowing condensate to be discharged.

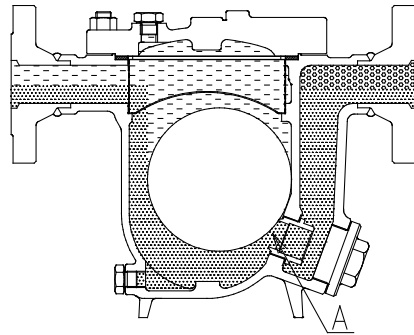

### 2. Discharge of Large Quantities of Condensate

Increases in the condensate inflow rate cause the condensate level in the trap to rise. The float consequently rises and enlarges the opening of the orifice (A), allowing more condensate to be discharged. In this manner, continuous condensate discharge occurs while the opening size of the orifice varies depending on the condensate flow rate.

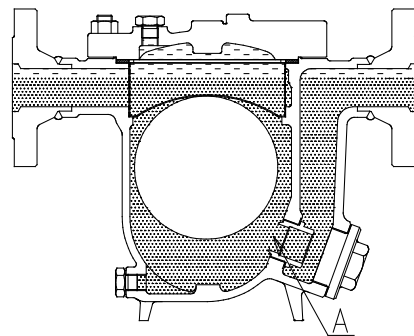

### 3. Closed Position

When the condensate flow rate decreases, the float falls, closing off the orifice (A) opening. A water seal is maintained at all times over the orifice (A) to prevent steam loss.

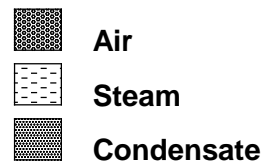
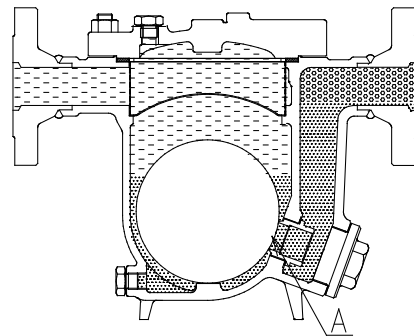

## Specifications



Install properly and **DO NOT** use this product outside the recommended operating pressure, temperature and other specification ranges. Improper use may result in such hazards as damage to the product or malfunctions which may lead to serious accidents. Local regulations may restrict the use of this product to below the conditions quoted.



**DO NOT** use this product in excess of the maximum operating pressure differential; such use could make discharge impossible (blocked).



Use only under conditions in which no freeze-up will occur. Freezing may damage the product, leading to fluid discharge, which may cause burns or other injury.

Refer to the product nameplate for detailed specifications.

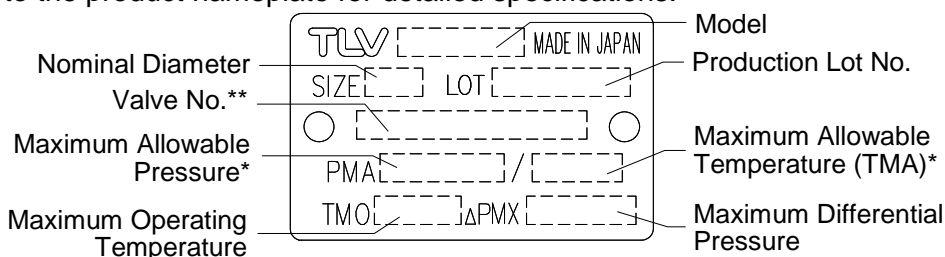

\* Maximum allowable pressure (PMA) and maximum allowable temperature (TMA) are PRESSURE SHELL DESIGN CONDITIONS, **NOT** OPERATING CONDITIONS.

\*\* Valve No. is displayed for products with options. This item is omitted from the nameplate when there are no options.

## Configuration

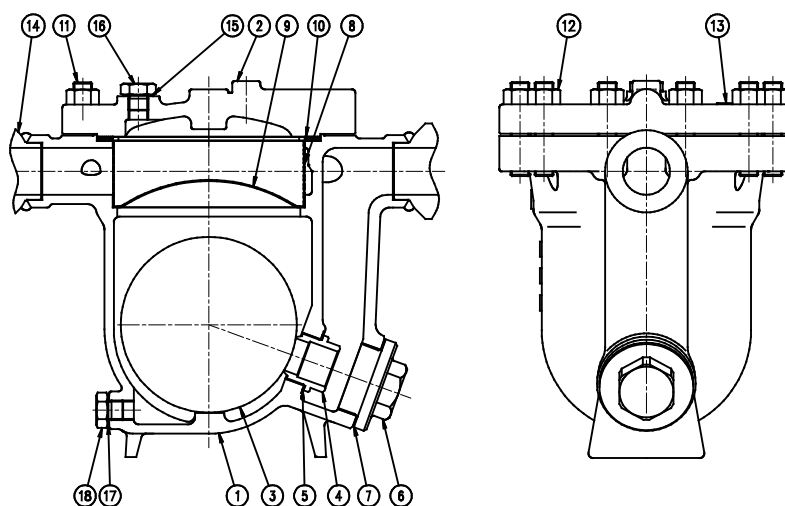

No.	Name	M*	R*	F*	No.	Name	M*	R*
1	Body				10	Cover Gasket	✓	✓
2	Cover				11	Cover Bolt		
3	Float			✓	12	Cover Nut		
4	Orifice		✓		13	Nameplate		
5	Orifice Gasket	✓	✓		14	Flange / Socket		
6	Orifice Plug				15	Cover Plug Gasket	✓	✓
7	Orifice Plug Gasket	✓	✓		16	Cover Plug		
8	Screen		✓		17	Drain Plug Gasket	✓	✓
9	Screen Holder				18	Drain Plug		

\* Replacement parts are available only in the following kits:

M = Maintenance Kit, R = Repair Kit, F = Float

## Installation



Install properly and **DO NOT** use this product outside the recommended operating pressure, temperature and other specification ranges. Improper use may result in such hazards as damage to the product or malfunctions which may lead to serious accidents. Local regulations may restrict the use of this product to below the conditions quoted.



Use hoisting equipment for heavy objects (weighing approximately 20 kg (44 lb) or more). Failure to do so may result in back strain or other injury if the object should fall.



Take measures to prevent people from coming into direct contact with product outlets. Failure to do so may result in burns or other injury from the discharge of fluids.

Installation, inspection, maintenance, repairs, disassembly, adjustment and valve opening/closing should be carried out only by trained maintenance personnel.

1. Before installation, be sure to remove all protective seals.
2. Before installing the product, open the inlet valve and blow out the piping to remove any piping scraps, dirt and oil. Close the inlet valve after blowdown.
3. Install the product so the arrow on the body is pointing in the direction of flow.
4. The trap should be inclined no more than 5° horizontally and front-to-back.
5. Install a condensate outlet valve and outlet piping.
6. Air in the system at start-up should be discharged using a bypass valve or blowdown line.
7. Open the inlet and outlet valves and check to make sure that the product functions properly.

If there is a problem, determine the cause using the “Troubleshooting” section in this manual.

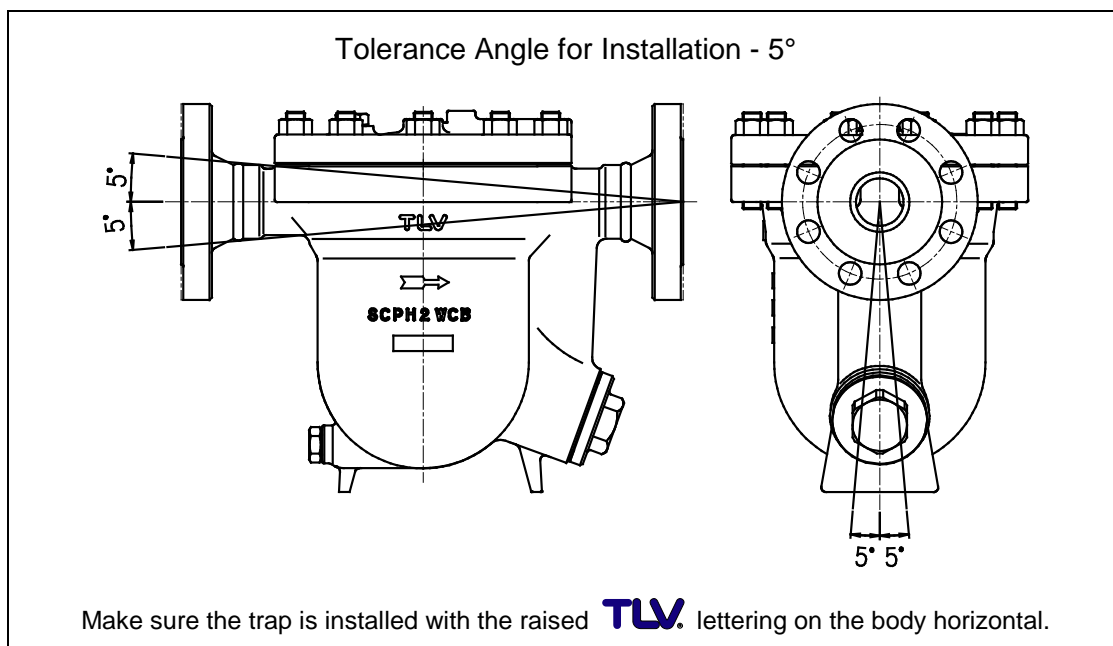



## Maintenance



Take measures to prevent people from coming into direct contact with product outlets. Failure to do so may result in burns or other injury from the discharge of fluids.



Be sure to use only the recommended components when repairing the product, and NEVER attempt to modify the product in any way. Failure to observe these precautions may result in damage to the product or burns or other injury due to malfunction or the discharge of fluids.

## Operational Check

A visual inspection of the following items should be done on a daily basis to determine whether the trap is operating properly or has failed. Periodically (at least biannually) the operation should also be checked by using diagnostic equipment, such as a stethoscope, thermometer, TLV Pocket TrapMan or TrapMan.

If the trap should fail, it may cause damage to piping and equipment, resulting in faulty or low quality products or losses due to steam leakage.

- Normal : Condensate is discharged continuously, together with flash steam, and the sound of flow can be heard. If there is very little condensate, there is almost no sound of flow.
- Blocked (Discharge Impossible) : No condensate is discharged. The trap is quiet and makes no noise, and the surface temperature of the trap is low.
- Blowing : Live steam continually flows from the outlet and there is a continuous metallic sound.
- Steam Leakage : Live steam is discharged through the trap outlet together with condensate, accompanied by a high-pitched sound.

(When conducting a visual inspection, flash steam is sometimes mistaken for steam leakage. For this reason, the use of a steam trap diagnostic instrument [TLV: TrapMan] in conjunction with the visual inspection is highly recommended.)

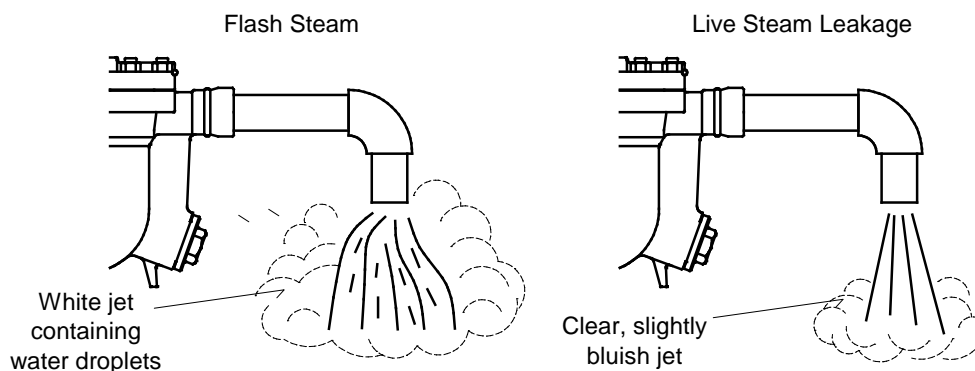

## Parts Inspection

When parts have been removed, or during periodic inspections, use the following table to inspect the parts and replace any that are found to be defective.

Procedure	
Gaskets:	check for warping or scratches
Screen:	check for clogging or corrosion
Float:	check for scratches or dents
Body interior:	check for build-up
Orifice Opening:	check for dirt, oil film, wear or scratches

## Disassembly / Reassembly



### WARNING

NEVER apply direct heat to the float. The float may explode due to increased internal pressure, causing accidents leading to serious injury or damage to property and equipment.



### CAUTION

Use hoisting equipment for heavy objects (weighing approximately 20 kg (44 lb) or more). Failure to do so may result in back strain or other injury if the object should fall.



### CAUTION

When disassembling or removing the product, wait until the internal pressure equals atmospheric pressure and the surface of the product has cooled to room temperature. Disassembling or removing the product when it is hot or under pressure may lead to discharge of fluids, causing burns, other injuries or damage.

Use the following procedures to remove components. Use the same procedures in reverse to reassemble. (Installation, inspection, maintenance, repairs, disassembly, adjustment and valve opening/closing should be carried out only by trained maintenance personnel.)

### Drain Plug

Part	During Disassembly	During Reassembly
Drain Plug	Remove with a socket wrench	Consult the table of tightening torques and tighten to the proper torque
Drain Plug Gasket	Remove the gasket and clean sealing surface	Replace with a new gasket; coat surfaces with anti-seize

### Detaching / Reattaching the Cover and its Components

Part	During Disassembly	During Reassembly
Cover Nut	Remove with a socket wrench	Consult the table of tightening torques and tighten to the proper torque
Cover	Remove, being careful not to scratch the gasket sealing surface	Make sure there are no pieces of the old gasket left on the sealing surfaces of the body and cover, align the arrows on the body and cover and reattach
Cover Gasket	Remove the gasket and clean sealing surface	Replace with a new gasket
Cover Plug	Remove with a socket wrench	Consult the table of tightening torques and tighten to the proper torque
Cover Plug Gasket	Remove the gasket and clean sealing surface	Replace with a new gasket; coat surfaces with anti-seize

### Disassembly / Reassembly of Components Inside the Body

Part	During Disassembly	During Reassembly
Screen	Remove by grasping the wire ring and lifting straight up and out	Set the screen on the screen holder and screen holder retainer and insert as far as the snap ring groove
Screen Holder	Remove without bending	Place on the ledge inside the body, making sure the rounded side is on top
Float	Remove, being careful not to scratch the polished surface	Insert, being careful not to scratch the polished surface
Orifice Plug	Remove with a socket wrench	Consult the table of tightening torques and tighten to the proper torque
Orifice Plug Gasket	Remove the gasket and clean sealing surface	Replace with a new gasket; coat surfaces with anti-seize
Orifice	Remove with a socket wrench	Consult the table of tightening torques and tighten to the proper torque
Orifice Gasket	Remove the gasket and clean sealing surface	Replace with a new gasket; coat surfaces with anti-seize

### Table of Tightening Torques

Part Name	Torque		Distance Across Flats	
	N·m	(lbf·ft)	mm	(in)
Cover Nut	180	(130)	24	( <sup>15</sup> / <sub>16</sub> )
Orifice Plug	700	(510)	46	(1 <sup>13</sup> / <sub>16</sub> )
Orifice	350	(260)	38	(1½)
Cover Plug (JH7.2R-P)	100	(73)	26	(1)
Drain Plug	100	(73)	26	(1)

NOTE: - Coat all threaded portions with anti-seize. (1 N·m ≈ 10 kg·cm)  
 - If drawings or other special documentation were supplied for the product, any torque given there takes precedence over values shown here.

**Exploded View**

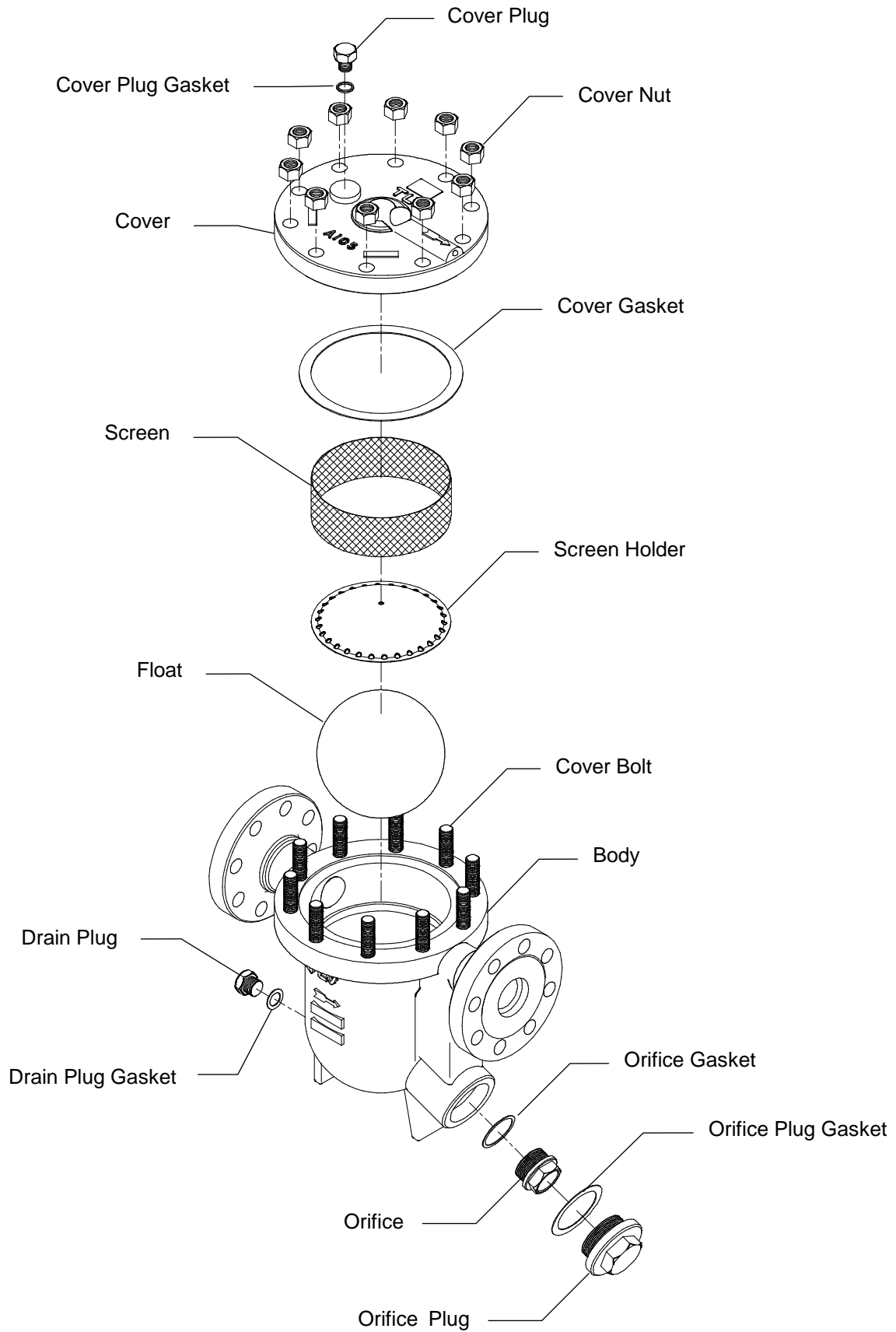

## Instructions for Plug / Holder Disassembly and Reassembly

The seal on the threaded plugs/holders found on TLV products is formed by a flat metal gasket. There are various installation orientations for the gaskets, such as horizontal, diagonal and downward, and the gasket may be pinched in the thread recesses during assembly.

### Instructions for Disassembly and Reassembly

- ① Remove the plug/holder using a tool of the specified size (distance across flats).
- ② The gasket should not be reused. Be sure to replace it with a new gasket.
- ③ Clean the gasket surfaces of the plug/holder and the product body using a rag and/or cleaning agents, then check to make sure the surfaces are not scratched or deformed.
- ④ Coat both the gasket surface of the plug/holder and the threads of the plug/holder with anti-seize, then press the gasket onto the center of the gasket surface of the plug/holder, making sure the anti-seize affixes the gasket tightly to the plug/holder. Check to make sure the gasket is not caught in the recesses of the threads.
- ⑤ Hold the plug/holder upside down to make sure that the anti-seize makes the gasket stick to the plug/holder even when the plug/holder is held upside down.
- ⑥ Screw the plug/holder by hand into the product body while making sure that the gasket remains tightly affixed to the center of the gasket surface of the plug/holder. Make sure the entire gasket is making contact with the gasket surface of the product body. It is important at this point to make sure the gasket is not pinched in the thread recesses of the plug/holder.
- ⑦ Tighten the plug/holder to the proper torque.
- ⑧ Next, begin the supply of steam and check to make sure there is no leakage from the part just tightened. If there is leakage, immediately close the inlet valve and, if there is a bypass valve, take the necessary steps to release any residual pressure. After the surface of the product cools to room temperature, repeat the procedure beginning from step 1.

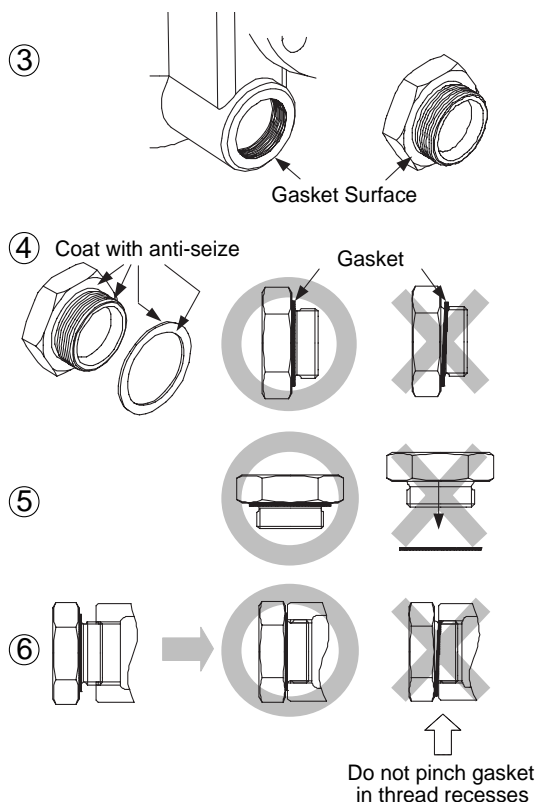

## Troubleshooting



### WARNING

NEVER apply direct heat to the float. The float may explode due to increased internal pressure, causing accidents leading to serious injury or damage to property and equipment.



### CAUTION

When disassembling or removing the product, wait until the internal pressure equals atmospheric pressure and the surface of the product has cooled to room temperature. Disassembling or removing the product when it is hot or under pressure may lead to discharge of fluids, causing burns, other injuries or damage.

When the product fails to operate properly, use the following table to locate and remedy the cause.

Problem	Cause	Remedy
No condensate is discharged (blocked) or discharge is poor	The float is damaged or filled with condensate	Replace with a new float
	The orifice opening, screen or piping are clogged with rust and scale	Clean parts
	The trap operating pressure exceeds the maximum specified pressure, or there is insufficient pressure differential between the trap inlet and outlet	Compare specifications and actual operating conditions
	Steam-locking has occurred	Perform a bypass blowdown or close the trap inlet valve and allow the trap to cool
	Air binding has occurred	Perform a bypass blowdown or consider switching to a product with a built-in air vent or air vent valve
Steam is discharged or leaks from the outlet (blowing) (steam leakage)	Build-up on the seating surface of the orifice or rust and scale build-up beneath the float	Clean parts
	Scratches on the orifice	Replace with a new orifice
	The float is misshapen or has a build-up	Clean or replace with new float
	Improper installation orientation	Correct the installation
	Trap vibration	Lengthen the inlet piping and fasten it securely
Steam is leaking from a place other than the outlet	Check for gasket deterioration or damage	Replace with new gasket(s)
	Check to make sure that the proper tightening torques were used	Tighten to the proper torque
Float frequently becomes damaged	Check to see if water hammer has occurred	Study and correct the piping

NOTE: When replacing parts with new, use the parts list for reference, and replace with parts from the Maintenance Kit, Repair Kit, etc. Please note that replacement parts are only available as part of a replacement parts kit.

## Product Warranty

1. Warranty Period  
One year following product delivery.
2. Warranty Coverage  
TLV CO., LTD. warrants this product to the original purchaser to be free from defective materials and workmanship. Under this warranty, the product will be repaired or replaced at our option, without charge for parts or labor.
3. This product warranty will not apply to cosmetic defects, nor to any product whose exterior has been damaged or defaced; nor does it apply in the following cases:
  - 1) Malfunctions due to improper installation, use, handling, etc., by other than TLV CO., LTD. authorized service representatives.
  - 2) Malfunctions due to dirt, scale, rust, etc.
  - 3) Malfunctions due to improper disassembly and reassembly, or inadequate inspection and maintenance by other than TLV CO., LTD. authorized service representatives.
  - 4) Malfunctions due to disasters or forces of nature.
  - 5) Accidents or malfunctions due to any other cause beyond the control of TLV CO., LTD.
4. Under no circumstances will TLV CO., LTD. be liable for consequential economic loss damage or consequential damage to property.

\* \* \* \* \*

For Service or Technical Assistance:

Contact your **TLV** representative or your regional **TLV** office.

### Manufacturer

**TLV** CO., LTD.  
881 Nagasuna, Noguchi  
Kakogawa, Hyogo 675-8511 JAPAN  
Tel: 81-(0)79 - 427 - 1800

## Options

The options shown below are available for this product on request. Please compare with the product you received.

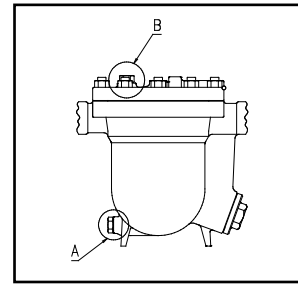

### Options for Area A (standard: with drain plug)

Without Drain Plug

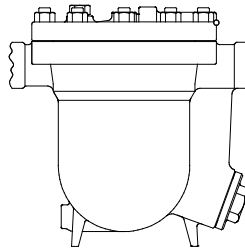

### Options for Area B (standard: with cover plug)

A pressure-balancing line connector can be attached to the place where the standard product has the cover plug.

Socket Type  
(Model: JH7.2R-W)

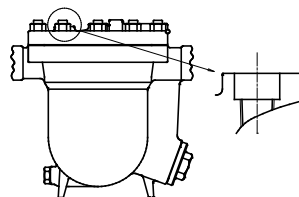

Flange Type  
(Model: JH7.2R-F)

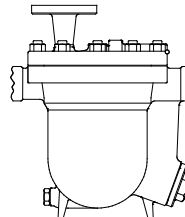

- In principle, steam traps automatically discharge inflowing condensate. However, if low-temperature condensate in the piping blocks the trap inlet passage, displacement inside the piping of steam by condensate is obstructed and condensate can no longer flow into the trap (steam-locking). Traps only function in the presence of condensate inflow. A pressure-balancing line prevents the occurrence of steam-locking.

Install the pressure-balancing line in the following manner:

Example: Heat Exchanger

Attach the pressure-balancing line to the trap and to either the equipment or to an area with a steam space.

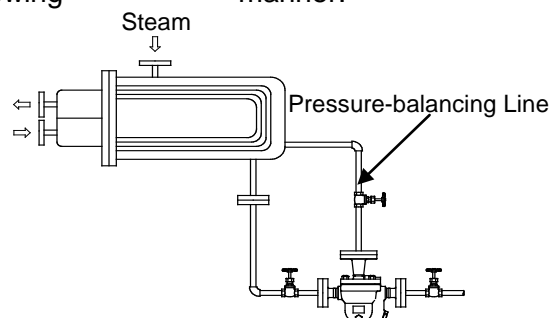



## Options for Area B

With Air Vent Valve  
(Model: JH7.2R-V)

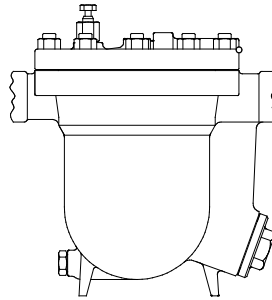

## Operating the Air Vent Valve



Be sure to use only the recommended components when repairing the product, and NEVER attempt to modify the product in any way. Failure to observe these precautions may result in damage to the product or burns or other injury due to malfunction or the discharge of fluids.

Installation, inspection, maintenance, repairs, disassembly, adjustment and valve opening/closing should be carried out only by trained maintenance personnel.

1. Locate the air vent valve exhaust port before operating the air vent valve, and take care to avoid being burned by hot air or steam blowing from the vent. The exhaust port is a 2 mm ( $1/16$ " ) diameter hole on the side of the air vent valve body.

**DO NOT** under any circumstances allow any unprotected part of your body to come in front of this hole.

2. Never leave an open air vent valve unattended.

Tools required: 1) open-end wrench (distance across flats 17 mm ( $21/32$ " ))

2) long-handled mirror to check for steam leakage after closing the exhaust port (leaking steam cloud the mirror)

- Using the open-end wrench, slowly turn the hexagonal head of the valve stem counterclockwise.
- Watch the exhaust port to determine the condition of the fluid discharged.

General guidelines:

Cloudy-water droplets and mist spraying out, indicating that air and condensate are being discharged

Clear---indicating that steam is being discharged; the valve port may now be closed

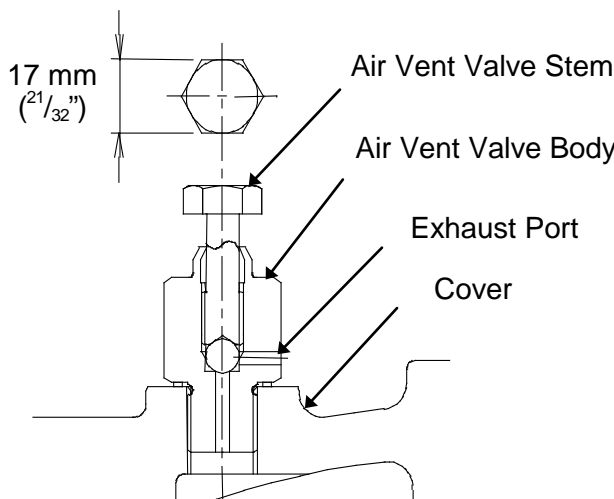

**CAUTION**

The air vent valve stem cannot be removed from the air vent valve body. Attempting to remove the valve stem by pulling it upward may damage it and cause burns or other injury due to malfunction or the discharge of steam or condensate.

3. Use the following procedure to close the valve and check for leaks:
  - Using the open-end wrench, close by slowly turning the hexagonal head of the valve stem clockwise until contact with the valve seat is felt.
  - Apply a little more pressure to tighten securely.  
 Note: Using an ordinary open-end wrench (handle length about 160 mm (6 1/4")), the valve will close with only a light turn pressure. Tightening with too much force may result in seizure or damage to the seat.
  - After tightening, place the mirror close to the front of the exhaust port. If the mirror clouds, the valve is not fully closed; tighten a bit more.
4. When air enters the piping at start-up, it may accumulate inside the trap and hinder the flow of condensate (air binding). Air binding may also occur during the normal course of trap operation, due to the slow accumulation of air inside the trap. The air vent valve on the top of this trap is to be operated only when air binding has occurred. Follow the instructions in the earlier part of this section to operate the air vent valve and release the air accumulated inside the trap. (The air vent valve is to be open only for as long as is necessary to release the accumulated air. If left open, it is extremely dangerous, so be sure to close tightly after operation.)

**Disassembly / Reassembly of Air Vent Valve**

Air Vent Valve Unit	Remove with a wrench	Consult the table of tightening torques and tighten to the proper torque
Air Vent Valve Gasket	Remove the gasket and clean sealing surface	Replace with a new gasket; coat surfaces with anti-seize

**Table of Tightening Torques**

Part Name	Torque		Distance Across Flats	
	N-m	(lbf-ft)	mm	(in)
Air Vent Valve Body	100	(73)	24	(15/16)

NOTE: -Coat all threaded portions with anti-seize. (1 N·m ≈ 10 kg·cm)  
 -If drawings or other special documentation were supplied for the product, any torque given there takes precedence over values shown here.