



Instruction Manual

SteamAqua[®]

Steam-Fired Instantaneous Water Heater

Compliant with the Water Supply Act (in Japan)

SQ10

Introduction

Thank you for purchasing the TLV steam-fired instantaneous water heater, SteamAqua (hereafter referred to as "the unit").

The unit has been thoroughly inspected before being shipped from the factory. When the unit is delivered, before doing anything else, check the specifications and external appearance to make sure nothing is out of the ordinary. Also be sure to read this manual carefully before use and follow the instructions to be sure of using the unit properly.

The unit has been certified by JET (Japan Electrical Safety & Environment Technology Laboratories) as a water supply instrument based on the Water Supply Act (in Japan).

If detailed instructions for special order specifications or options not contained in this manual are required, please contact TLV for full details.

Be sure to read the "Installation/Commissioning" chapter of this manual before installation. After reading and understanding its contents, correctly install the unit.

This manual should also be referred to for commissioning, and for daily operation, maintenance inspection, and when troubleshooting.

This instruction manual is intended for use with the model(s) listed on the front cover. It is necessary not only for installation but for subsequent maintenance and troubleshooting. Please keep it in a safe place for future reference.

Important Notice

The copyright of this manual belongs to TLV CO., LTD. Unauthorized reproduction of the contents of this manual in part or in whole is strictly prohibited.

This manual should be kept for future reference. If it becomes defaced or is misplaced, contact your local TLV representative, or download from the TLV website (<https://www.tlv.com>).

The contents of this manual are subject to change without notice. Please note that visuals such as the diagrams and illustrations found within this manual may differ slightly from the actual unit.

This manual was written for the purpose of use of the unit in the Japanese market.

Please carefully read all other documentation included for this unit and its components.

Make sure that the person supervising operation of the unit has received a thorough briefing on the contents of the 'Report on Commissioning Results' which is issued after finishing the commissioning.

Contents





Introduction.....	1
Operation	3
Safety Considerations	4
Temperature Stability	8
Configuration (Component Name and Function)	9
Optional Equipment Configuration	11
Control Panel Configuration	12
Touch Panel Display	13
Safety Function (Abnormal Temperature Rise Preventing Function).	24
Operation Flow	25
Operation Procedure	26
Prevention of Damage due to Freezing	30
Maintenance and Inspection	31
Storage	34
Storage Instructions	34
Troubleshooting.....	35
Service or Technical Assistance	37
Specifications	38
Disposal of the Unit	38
Product Warranty	39
Installation/Commissioning	42
Introduction.....	43
Safety Considerations	43
Precautions for Opening and Moving the Package.....	49
Precautions before Unit and Piping Installation	51
Piping Work.....	53
Installing Several SteamAqua Units in Parallel	58
Electrical Wiring.....	59
Commissioning Procedure	64
TLV EXPRESS LIMITED WARRANTY	71
Service	73

Operation

Safety Considerations

- Read this section carefully before use and be sure to follow the instructions.
- Installation, inspection, maintenance, repairs, disassembly, adjustment and valve opening/closing should be carried out only by trained maintenance personnel.
- The precautions listed in this manual are designed to ensure safety and prevent equipment damage and personal injury. For situations that may occur as a result of erroneous handling, three different types of cautionary items are used to indicate the degree of urgency and the scale of potential damage and danger: DANGER, WARNING and CAUTION.
- The three types of cautionary items above are very important for safety: be sure to observe all of them as they relate to installation, use, maintenance, and repair. Furthermore, TLV accepts no responsibility for any accidents or damage occurring as a result of failure to observe these precautions.
- There is a space under the control panel of the unit for storage of this manual.

Symbols

	Indicates a DANGER, WARNING and CAUTION item.
	Indicates an urgent situation which poses a threat of death or serious injury
	Indicates that there is a potential threat of death or serious injury
	Indicates that there is a possibility of injury or equipment/product damage

Be sure to follow the instructions, as each contains important information regarding safety.

To use the unit correctly and safely, be sure to follow the safety considerations written in this manual when checking the unit's "Caution/Warning sticker", installing the unit and/or wiring, starting or stopping operation, or carrying out maintenance or repairs etc.

Furthermore, TLV CO., LTD. does not bear responsibility or guarantee the unit for damages or accidents that arise from not following these considerations.

Checking the "Caution/Warning Stickers"

"Caution/Warning stickers" can be found on both the unit and some components. The operator of this unit should understand what is written on the "Caution/Warning stickers" before operating the unit.

Precautions for the Entire Unit

 CAUTION	<p>Install properly and DO NOT use this unit outside the recommended operating pressure, temperature and other specification ranges. Improper use may result in such hazards as damage to the unit or malfunctions that may lead to serious accidents. Local regulations may restrict the use of the unit to below the conditions quoted.</p>
	<p>When the unit is directly connected to municipal water supply piping, back flow prevention measures must be taken in accordance with the Water Supply Act (in Japan). Failure to do so may lead to serious accidents in the water main line.</p>
	<p>Use hoisting equipment for heavy objects (weighing approximately 20 kg or more). Failure to do so may result in back strain or other injury if the object should fall.</p>
	<p>Take measures to prevent people from coming into direct contact with the condensate outlet of the unit. Failure to do so may result in burns or other injury from the discharge of fluids.</p>
	<p>When disassembling or removing the unit and its components, wait until the internal pressure equals atmospheric pressure and the surface of the components have cooled to room temperature. Disassembling or removing components when hot or under pressure may lead to discharge of fluids, causing burns, other injuries or damage.</p>
	<p>Be sure to use only the recommended components when repairing the unit, and NEVER attempt to modify the unit in any way. Failure to observe these precautions may result in damage to the unit and burns or other injury due to malfunction or the discharge of fluids.</p>
	<p>Do not use excessive force when connecting threaded pipes to the unit. Over-tightening may cause breakage leading to fluid discharge, which may cause burns or other injury.</p>
	<p>Use only under conditions in which no freeze-up will occur. Freezing may damage the unit, leading to fluid discharge, which may cause burns or other injury.</p>
	<p>Use only under conditions in which no water hammer will occur. The impact of water hammer may damage the unit, leading to fluid discharge, which may cause burns or other injury.</p>
	<p>Make sure the power supply is OFF before carrying out work on the wiring or inspections involving disassembly. If such work is carried out with the power on, there is a danger that components may malfunction or electric shock may occur, leading to injury or other accidents.</p>
<p>Make sure that wiring work requiring a special license is carried out by qualified personnel. If carried out by unqualified personnel, overheating or short circuits leading to injury, fires, damage or other accidents may occur.</p>	

Precautions for Operation

	<p>When initially starting up the unit, make sure to check the display the measured temperature to prevent burns and do not touch the water until the temperature becomes stable. Be careful especially when using the water is used at high temperature.</p> <p>Failure to observe these precautions is dangerous, as there is a possibility that residual water in the pipe line, which is hotter than the set temperature, may flow.</p>
	<p>The unit should be operated in accordance with the proper operating steps, within the specifications of the unit, such as the maximum operating pressure (PMO) and maximum operating temperature (TMO). Refrain from sudden operation of any valves.</p> <p>Failure to observe these precautions is dangerous and may result in damage to the unit, malfunctions or failure of the unit, or lead to serious accidents.</p>
	<p>Do not intentionally allow the control panel to become wet.</p> <p>Operation of the unit while the control panel is wet may result in electric shock and/or malfunction of the unit.</p>
	<p>The tank must be full of water before operating the heat exchanger. In particular, if water has been discharged from inside the heat exchanger for freeze prevention etc., make sure to restart the unit after supplying water to the heat exchanger. (When the cooling circulation unit (optional) is installed.)</p> <p>Operating the heat exchanger empty of water for a long period of time is dangerous, and may result in the pump running dry and becoming damaged. .</p>
	<p>Do not rapidly reduce the valve opening on the hot water line. If it is reduced rapidly, do not touch the water for 30 seconds.</p> <p>Failure to observe this precaution is dangerous, as there is a possibility that water at a temperature higher than the set temperature may temporarily flow.</p>
	<p>Do not change the temperature settings without contacting the water user when washing hands, using a shower or cleaning.</p> <p>Failure to do so may result in burns to the water user.</p>
	<p>Each component of the unit such as the steam piping, motorized valve, control valve, etc. may become hot. Do not touch components with bare hands.</p> <p>Failure to observe these precautions may result in burns.</p>
	<p>In the event of an earthquake, close the main steam supply valve and shut down the unit promptly, then turn off the breaker.</p> <p>If the tube inside the heat exchanger of this unit is damaged due to an earthquake, a large amount of steam will enter the hot water piping, which may result in burns.</p>
	<p>Valve and unit operation must be carried out by personnel who have attended operation training ensuring the use of heat-resistant gloves, helmet, protective glasses, etc. to prevent burns.</p> <p>Failure to do so may result in burns, as the piping and cover of the unit become hot during operation.</p>

Continued on the next page

 CAUTION	<p>When finishing operation, the operation should be stopped in accordance with the proper steps. Incorrect operation of the unit during use for handwashing or showering, or cleaning, etc., may result in burns due to malfunction, which causes the temperature of the water to rise above the set temperature.</p>
	<p>When draining water from the unit, make sure to wait until the unit has cooled down. If carrying out work after hot water use, there is a risk of burns, as the components and the water inside the unit are hot.</p>

Precautions when the Unit is Shut Down for a Long Period of Time

 CAUTION	<p>When the unit is shut down for a long period of time or there is a possibility of freezing, make sure to completely discharge steam condensate or water in the unit and its components such as the steam piping, heat exchanger, etc. After doing so, there is a risk of burns or injury during operation start-up, as fluid may be discharged from piping.</p>
--	---

Precautions when Maintenance or Inspection is Conducted

 CAUTION	<p>Be sure to use only the recommended components when repairing the unit and its components, and NEVER attempt to modify the unit in any way. Failure to observe these precautions may result in damage to the unit or burns or other injury due to malfunction or the discharge of fluids.</p>
	<p>Do not climb on the components of the unit. The unit is not designed to be climbed on by people. Failure to observe this precaution may lead to injury, failure or abnormal operation due to deformation of the unit.</p>
	<p>When disassembling or removing the unit and its components, wait until the internal pressure equals atmospheric pressure and the surface of the components have cooled to room temperature. Disassembling or removing components when hot or under pressure may lead to discharge of fluids, causing burns, other injuries or damage.</p>
	<p>Do not disassemble, repair or modify the control panel by yourself. Failure to observe these precautions may result in burns, etc. due to malfunction.</p>
	<p>Make sure that the unit is used at a power supply specification matching the unit specifications. In particular, ensure that the power supply specification matches when moving the unit. Failure to do so may result in damage to the unit.</p>
	<p>Make sure to wear protective gear such as a helmet, safety glasses, long-sleeve shirt, heat-resistant gloves, protective footwear, etc. Failure to do so may result in burns or injuries.</p>
	<p>In case of an abnormality, install a safety fence or restrict access to the room with a sign stating "Authorized personnel only." etc. to prevent personnel unauthorized for the unit (including those who have not received the relevant safety education) touching the components. When doing so, stop the supply of steam, electrical power, water and air. Failure to prevent the access of unauthorized personnel may result in burns, electric shock, injury, or falls.</p>

Temperature Stability

The unit is capable of supplying water with a temperature deviation of ± 1 °C of the set temperature when there is little fluctuation in the amount of water and the unit is in stable operation. However, rapid operation of the valve for water supply, or rapid temperature changes of the supply water, may temporarily result in a temperature deviation greater than 1 °C of the set temperature.

The valve for water supply system should be adjusted as slowly as possible.

For reference, the table below gives examples of possible water temperature deviations, at a set temperature of 60 °C and 0.3 MPaG steam pressure, according to the relative change of water flow rate and valve operation time.

Example 1 below shows that when reducing the flow rate of the supply water from 2 m³/h to 1 m³/h (relative change of 50%), even operating the water supply valve for 30 seconds will result in a temporary water temperature deviation of ± 3 °C.

Example 4 shows that when reducing the flow rate of the water supply from 16 m³/h to 15 m³/h (relative change of 6%), even rapid operation of the water supply valve will result in a temporary water temperature variation of only ± 1 °C.

As the water temperature deviation increases with the relative change of water flow rate and reciprocal to valve operation time, operate the valve over a period equal to or longer than the corresponding valve operation time in order to keep the water temperature deviation equal to or lower than the value shown in the table below.

No.	Water Flow Rate Change (m ³ /h)	Relative Change of Water Flow Rate (%)	Valve Operation Time (seconds)	Water Temperature Deviation (°C)
1	2 → 1	50	30	± 3
2	4 → 3	25	3	± 3
3	8 → 7	12.5	0.5	± 1.5
4	16 → 15	6	0.3	± 1

Configuration (Component Name and Function)

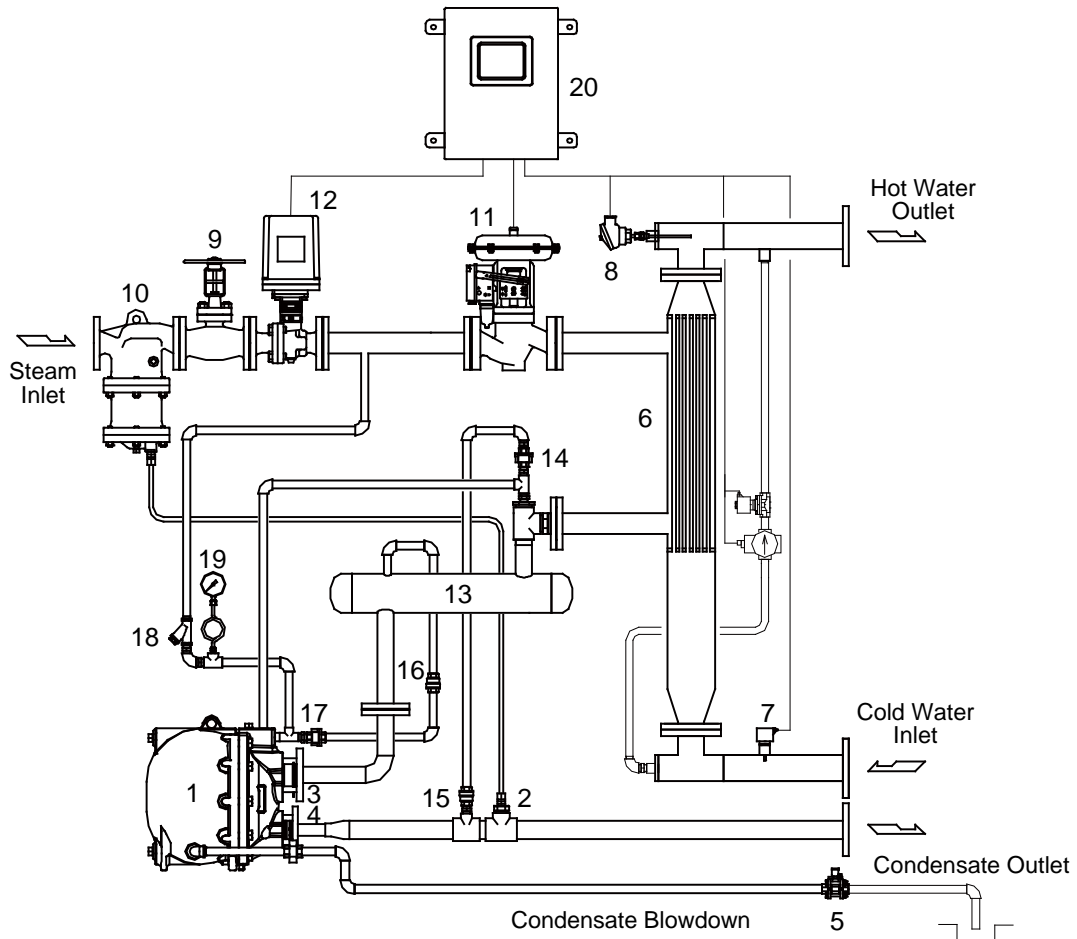
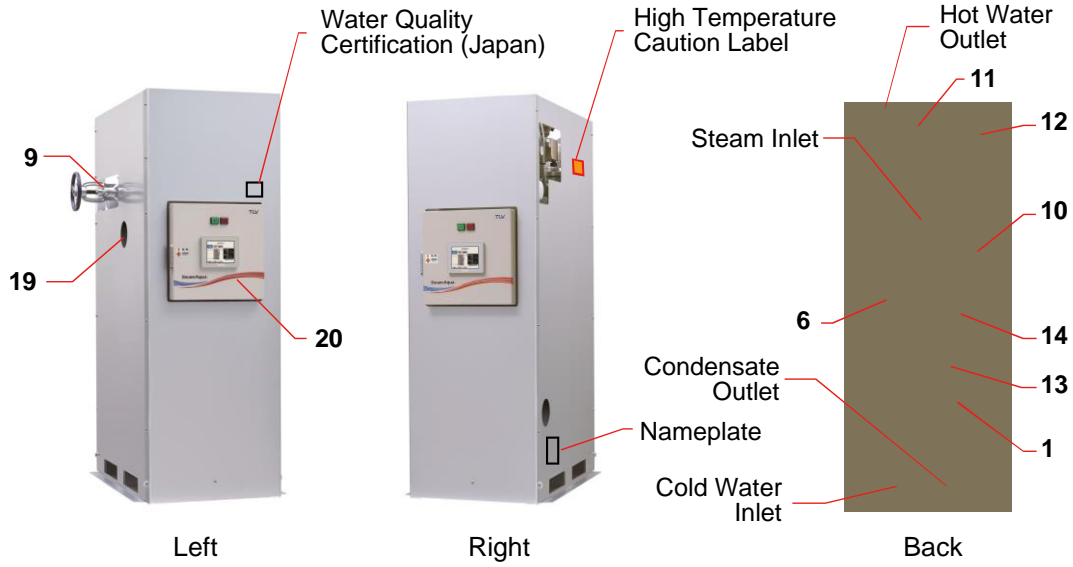

Component Configuration

Name	No.	Component	Description
Condensate Discharge Unit	1	PowerTrap	<p>Removes steam condensate consumed by the heat exchanger to produce hot water.</p> <ul style="list-style-type: none"> • The PowerTrap has both a steam trap function, and a pump function for discharging condensate even when there is very little pressure from the heat exchanger side. • The silencing bush reduces the sound of water hammer generated by flash steam and cold condensate in contact.
	2	Silencing Bush	
	3, 4	Check Valve	
	5	Condensate Blowdown Valve	
Heat Exchanger Unit	6	Heat Exchanger	<p>Produces hot water by exchanging heat from steam supplied by the steam supply unit to water.</p> <ul style="list-style-type: none"> • The flow sensor stops supplying steam when the water flow rate becomes equal to or lower than the controllable flow rate.
	7	Flow Sensor	
	8	Temperature Sensor	
Steam Supply Unit	9	Steam Inlet Valve	<p>Supplies the required amount of dry steam for the water temperature to become the set temperature.</p> <ul style="list-style-type: none"> • The control valve is pneumatically actuated. • Condensate separator separates and removes condensate in the steam piping. • When the unit stops or becomes abnormally high temperature, the motorized valve shuts out steam, preventing steam flowing into the heat exchanger.
	10	Condensate Separator	
	11	Control Valve	
	12	Motorized Valve	
Receiver Unit	13	Condensate Receiver	<p>Stores steam condensate temporarily while the PowerTrap discharges condensate.</p> <ul style="list-style-type: none"> • The air vent for steam removes air in the steam piping during initial operation.
	14	Air Vent for Steam	
	15	Check Valve	
PowerTrap Motive Steam Supply Unit	16	Check Valve	<p>Supplies motive steam to the PowerTrap for the pump operation.</p> <ul style="list-style-type: none"> • Steam trap (17) discharges condensate in the supply pipe. Discharged condensate flows into the condensate receiver (13). • Pressure gauge (19) indicates the source pressure of the steam.
	17	Steam Trap	
	18	Strainer	
	19	Pressure Gauge	
Control Panel	20	Control Panel	<p>Starts/stops operation and allows unit setting changes.</p> <ul style="list-style-type: none"> • Display of currently flowing hot water temperature and set temperature. • Adjust set temperature. • Sets/cancels each alarm.

Optional Equipment Configuration

External view of the standard product

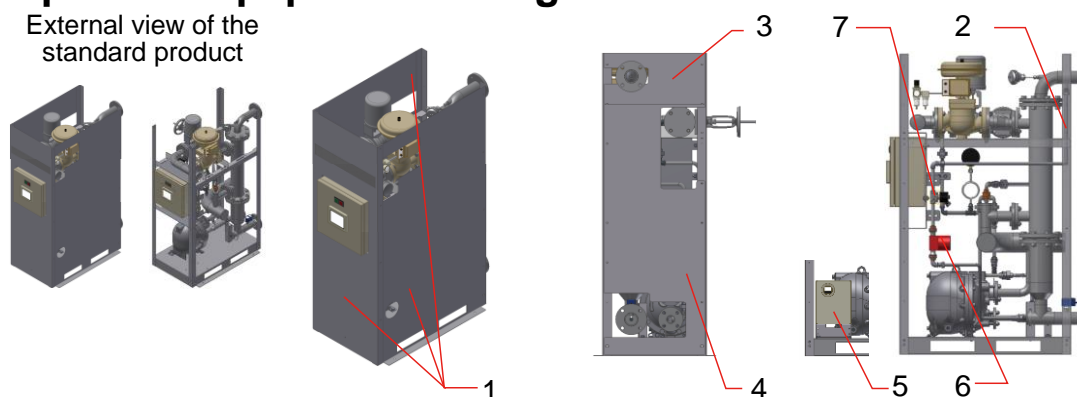

Optional Equipment

Option	No.	Component	Description
Stainless Steel 3-sided Cover/ Stainless Steel Frame Unit	1	3-sided Cover (Front, Left, Right)	The panel and frame (including base) material of the unit can be changed from iron to stainless steel.
	2	Base & Frame Unit	
Back Cover	3	Upper Back Cover	Can be installed at the back of the unit. <ul style="list-style-type: none"> • The cover is divided into upper and lower parts. • The material for the back cover is SUS304 stainless steel regardless of the frame material.
	4	Lower Back Cover	
Control Panel for Connection to Circulating Pump	5	Control Panel for Connection to Circulating Pump	A control panel can be installed for connecting the unit start-up to a low-power pump on a closed (hot) water circulation system. <ul style="list-style-type: none"> • Supply/control of motive power for 100 V AC single-phase pumps of 0.4 kW or less. • Pump not included in this option.
Cooling Circulation Unit	6	Circulating Pump	Additional safety function. <ul style="list-style-type: none"> • To prevent the water temperature exceeding the set temperature, water from the heat exchanger is circulated to prevent further temperature rise.
	7	Solenoid Valve	
Power Supply Voltage	—	Control Panel, Motorized Valve	Sets the power supply to the unit to 200 V. (Standard: 100 V AC) <ul style="list-style-type: none"> • The frequency is 50/60 Hz.

Control Panel Configuration

Front cover of the control panel

The front cover of the control panel is configured as shown in Figure A.

Since the electrical components are mounted behind the front cover inside the panel, it must not be opened by anyone other than a qualified electrician.

Figure B shows the internal configuration of the control panel. When a qualified electrician checks wiring or works on the control panel, ensure the main power is switched off and confirm that the power indicator (No. 3) is off.

(The layout of each component inside the control panel, as shown in Figure B, may differ from the layout in actual units.)

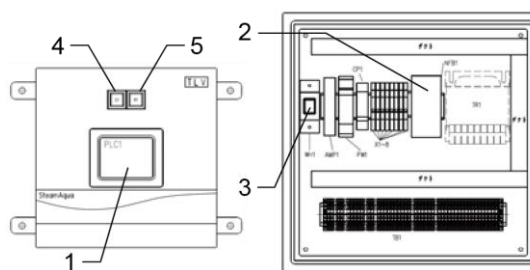

Figure A
Front panel

Figure B
Inside

No.	Name	Description
1	Touch Panel Display	All parameters, such as starting/stopping unit operation and changing the set temperature, can be confirmed and set via the display. <ul style="list-style-type: none"> All basic operations are performed using this touch panel display.
2	Earth Leakage Circuit Breaker (Non-fuse Breaker)	Circuit breaker for the unit. <ul style="list-style-type: none"> The circuit breaker is OFF when shipped. Make sure the breaker is turned ON by a qualified electrician or TLV personnel.
3	Power Supply Indicator (White)	Lights up when power is supplied to the control panel at 100 V AC. <ul style="list-style-type: none"> Lit while power is supplied, whether in operation or not.
4	Operation Lamp (Green)	Lights up when the operation button for the unit is switched ON. <ul style="list-style-type: none"> Automatic operation (water flow sensing, opening/closing of the steam valve, steam control, etc.) is performed while the operation lamp is lit.
5	Temperature Abnormal Alarm (Red)	Lights up when low temperature alarm or high temperature alarm is triggered. <ul style="list-style-type: none"> Refer to the "Alarm Log Screen" section for details. The unit still operates automatically when low temperature alarm is triggered. The unit will stop operates automatically and switches to standby mode (refer to the "Alarm Log Screen" section for details) when high temperature alarm is triggered. The lamp turns off once the unit is recovered from abnormalities.

Touch Panel Display

Items used during normal operation

The following items can be operated with the touch panel display to;

1. Starting operation of the unit,
2. Stopping operation of the unit, or
3. Adjusting the set (target) temperature.

The three buttons shown in the figure to the right are used during normal operation.

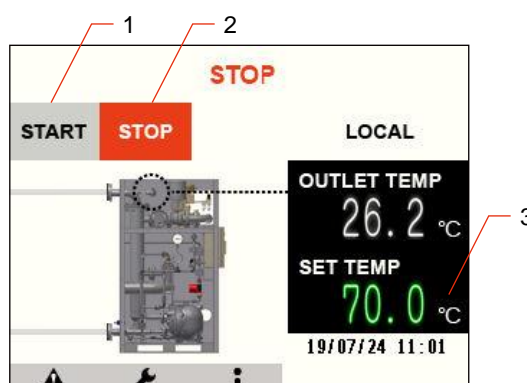

No.	Name	Description
1	Operation Display and START Button	<p>Starts automatic operation (automatic temperature adjustment) or ready to start automatic operation.</p> <ul style="list-style-type: none"> The button is activated by touching it for 0.5 seconds. START : In operation (blue), START : Not in operation (gray)
2	Operation Display and STOP Button	<p>Stops automatic operation, also for emergency use.</p> <ul style="list-style-type: none"> The button is enabled by touching it for 0.5 seconds. STOP : In operation (gray), STOP : Not in operation (red)
3	SET TEMP Display and SET TEMP Adjustment Button	<p>Displays the current set (target) value for the water temperature. Set temperature can be adjusted by touching the displayed numbers.</p> <ul style="list-style-type: none"> The set temperature can be adjusted only when adjustment input is carried out directly via this control panel. (However, operations such as set temperature display and adjustment, as described in the "Installation/ Commissioning" chapter, cannot be performed via external input/output.) When the set temperature can be adjusted via this control panel, the numbers will be displayed in green. When adjusting the set temperature via an external signal, the numbers will be displayed in white. <p>Set temperature adjustment via external signal (Green) Set temperature adjustment via control panel (White)</p> <div style="display: flex; justify-content: space-around; align-items: center;"> <div style="text-align: center;"> </div> <div style="text-align: center;"> </div> </div>

Main Screen

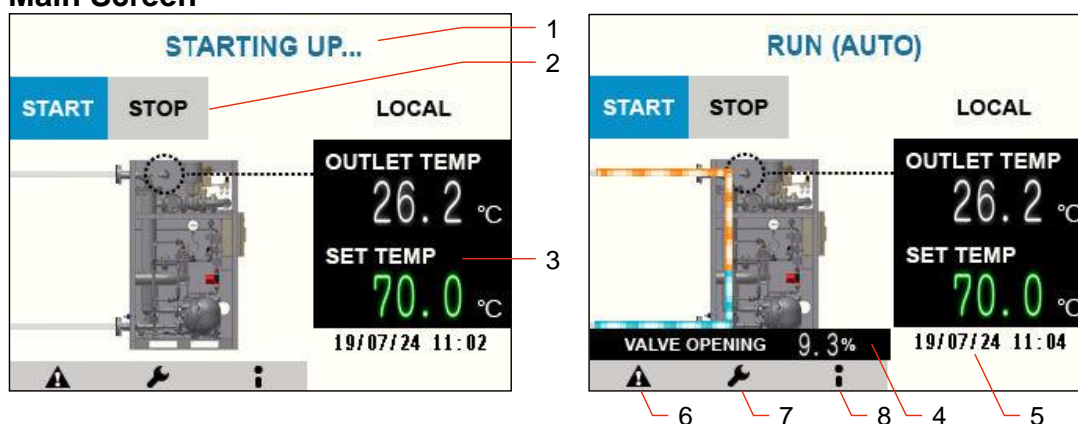

No.	Name	Description
1	Operating Status	<p>Displays the current operating status (STOP / STARTING UP... / RUN (AUTO) / STOPPING...).</p> <ul style="list-style-type: none"> • STOP: Operation is stopped. During this state, no heating will be performed. • STARTING UP...: When the flow sensor detects water flow, the unit switches to automatic operation. • RUN (AUTO): The control valve opens and heating is carried out. • STOPPING...: When the internal cooling circuit is in action, after the STOP button has been touched.
2	Set Temperature Input Location	<p>Displayed in green when the temperature setting value is input via external input (4 to 20 mA).</p> <ul style="list-style-type: none"> • When the target value is input and determined via the control panel, the text is displayed in gray.
3	OUTLET TEMP	<p>Displays the current water temperature at the outlet of the unit.</p> <ul style="list-style-type: none"> • The temperature is measured near the hot water outlet of the unit.
4	VALVE OPENING	<p>Displays the current valve opening of the control valve.</p> <ul style="list-style-type: none"> • Displayed range: 0 to 100% <p>(The value is not displayed unless Display Valve Opening is ON on the parameter settings screen, as described in a later section.)</p>
5	Current Time	<p>Displays the current time.</p> <ul style="list-style-type: none"> • Display format: YY/MM/DD hh:mm <p>(The current time can be adjusted on the parameter setting screen, as described in a later section.)</p>
6	Alarm Log	<p>Displays the alarm log screen.</p> <ul style="list-style-type: none"> • Alarm log (including active alarms) can be confirmed and deleted (only alarms that have been resolved can be deleted). (For more details, refer to the "Alarm log screen" section.)
7	Parameter Settings	<p>Displays the parameter setting(s) screen.</p> <ul style="list-style-type: none"> • Alarm conditions, control PID value, time, etc. can be changed or set. <p>(For more details, refer to the "Alarm log screen" section.)</p>
8	Contact Information	<p>Displays contact information for TLV.</p> <ul style="list-style-type: none"> • Contact information for TLV or TLV service and technical assistance personnel and the serial no. for the unit can be confirmed.

Flow display on the main screen

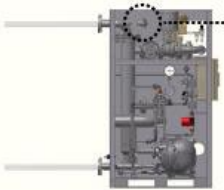
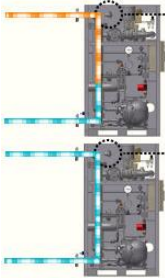
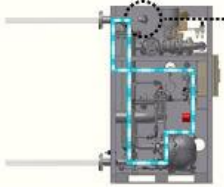
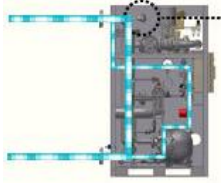
Screen Display	Status	Description
	The water flow rate is less than the set water amount for the flow sensor	<p>The amount of water flowing is less than the set water amount for the flow sensor (default: the amount of water that can be controlled under stable conditions)</p> <ul style="list-style-type: none"> • The unit is on stand-by because there is little or no water flow. • In this status, steam supply (control) cannot be performed by touching the START button.
	The water flow rate is more than (or equal to) the set water amount for the flow sensor	<p>The amount of water flowing is more than or equal to the set water amount for the flow sensor.</p> <ul style="list-style-type: none"> • When on stand-by, steam supply will start after a certain period of time. • Once steam supply is started, the water displayed in the image after the heat exchanger changes to orange.
	Cooling circulation unit is in operation (The water flow rate is less than the set water amount for the flow sensor)	<p>There is little or no water flowing, but the cooling circulation unit is in operation.</p> <ul style="list-style-type: none"> • When at an abnormally high temperature with no flow, the water inside the heat exchanger is cooled. <p>(Only displayed when the cooling circulation unit (optional) is installed.)</p>
	Cooling circulation unit is in operation (The water flow rate is more than (or equal to) the set water amount for the flow sensor)	<p>The cooling circulation unit is in operation, and water is flowing.</p> <ul style="list-style-type: none"> • When there is a flow, and the unit is at an abnormally high temperature, water will flow towards the hot water outlet and be cooled. <p>(Only displayed when the cooling circulation unit (optional) is installed.)</p>

Alarm Log Screen

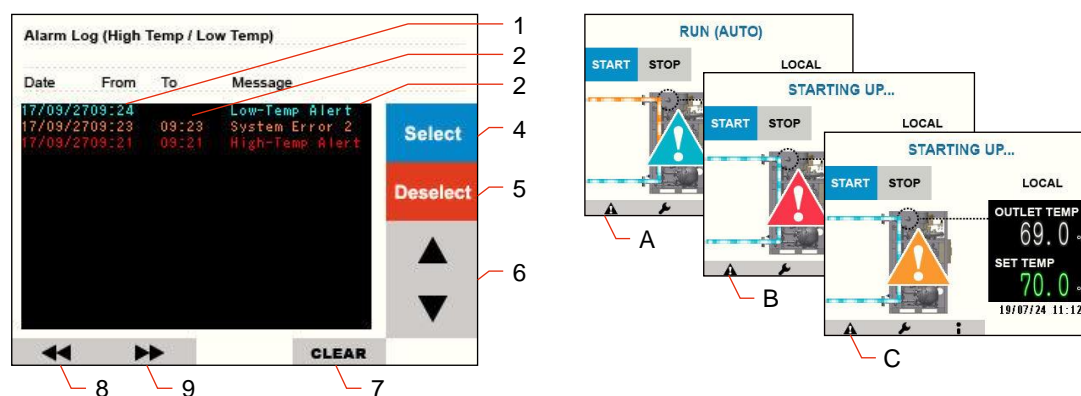

No.	Function	Description
1	Alarm Time	Displays the date and time (yy/mm/dd hh:mm) of an alarm. • The displayed time is derived from the clock on the display.
2	Alarm Details	Displays alarm details. • Low Temp Alarm : Triggered when the water temperature is below the alarm trigger temperature (defined as: set temperature – lower limit) for a certain period of time, and is displayed in blue text. It is also displayed on the main screen (A) (blue) when triggered. • High Temp Alarm : Triggered when the water temperature exceeds the alarm trigger temperature (defined as: set temperature + upper limit) for a certain period of time, and is displayed in red text. It is also displayed on the main screen (B) (red) when triggered. • Abnormal System Alarm 1: Triggered when any of the following occur: an abnormality in the analog input/output circuit inside the sequencer, an abnormality in the temperature sensor, or if any wires are disconnected. Displayed in amber text. It is also displayed on the main screen (C) (amber) when triggered. • Abnormal System Alarm 2: Triggered when there is no change in the temperature sensor measured value for a certain period of time during steam heating, and is displayed in amber text. It is also displayed on the main screen (C) (amber) when triggered.
3	Alarm Recovery Time	Displays the alarm recovery time (hh:mm). • The time is displayed when the unit recovers from an alarm status. (If after recovery the unit returns to an alarm status, it will be displayed as a separate alarm.) • If an alarm is displayed without a recovery time, then the alarm is active. • The displayed time is derived from the clock on the display.
4	Select Button	Enters the alarm log edit mode. • Executable actions in the edit mode: deleting alarm log records, displaying alarm log records that are not shown due to the display limit for the screen (14 records).
5	Deselect Button	Exits the alarm log edit mode.
6	▲/▼ (Up/Down) Button	Scrolls up/down the alarm log display. • When 14 or fewer alarm logs are displayed, the cursor will only move inside the white area of the screen.
7	CLEAR Button	Deletes all alarm log records. • Only recovered alarms will be deleted. (Active alarms will not be deleted.)
8	◀ (Back) Button	Returns to the main screen.
9	▶▶ (Data Log Function) Button	Displays the data log function screen. • Trend data such as water temperature can be confirmed/recorded.

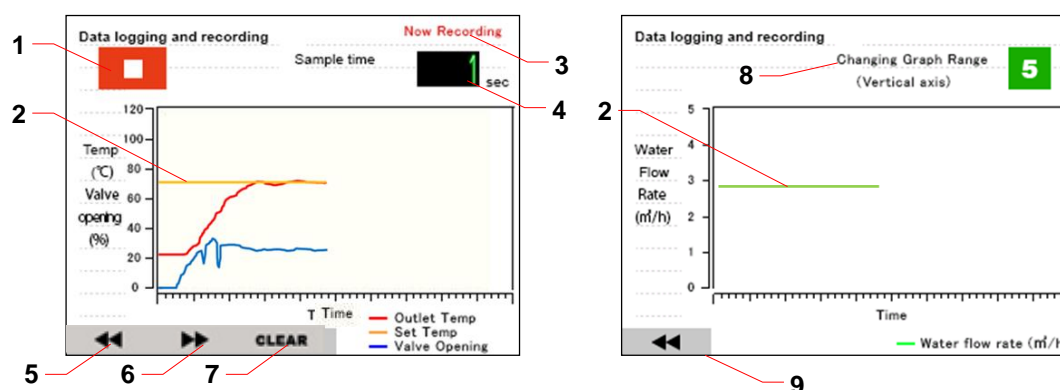

Data Log Function Screen

Recorded hot water outlet temperature (measured value, target value) and valve opening data can be output to an external storage device via the USB port.



Data log function screen (1)

Data log function screen (2)

No.	Function	Description
1	Start/End Recording	Starts/ends trend data recording/display <ul style="list-style-type: none"> Starts data recording/display. (When data is not currently being recorded/displayed.) Stops data recording/display. (While data is being recorded/displayed.)  
2	Trend Data	Displays various trend data against elapsed time. <ul style="list-style-type: none"> Hot water outlet temperature (PV): Displays the measured value of the hot water outlet temperature. Hot water outlet temperature (SV): Displays the target water temperature. Valve opening (%): Displays the degree of opening of the control valve. Hot water flow rate (m³/h): Displays the measured value of the hot water flow rate.
3	Writing...	Indicates that trend data is being displayed or written.
4	Sampling Time	Sets the sampling time. <ul style="list-style-type: none"> Factory setting: 1 Setting range: 1 to 6000 seconds
5	◀◀ (Back Button)	Returns to the alarm log screen.
6	CLEAR Button	Clears the displayed trend data. <ul style="list-style-type: none"> Does not clear data already written to a USB device.

Trend data output (data log function)

(1) Preparing for data transfer (recording)

For trend data output, prepare a USB device.

(USB device not included with the unit.)

- a) Open the front cover of the control panel.
(Control panel for outdoor specifications: the inner cover of the control panel should be opened.)
For safe use, make sure the breaker is switched OFF when removing/inserting the USB device.
- b) Insert the USB device into the USB port on the touch panel display inside the control panel.
- c) Once the USB device is inserted, switch the breaker ON and close the front cover of the control panel. (Control panel for outdoor specifications: the inner cover of the control panel should be closed.)



Figure:
Inside the control panel

When the USB device is recognized by the unit, the USB icon will be displayed in the lower right of the touch panel display.

(2) Data transfer (recording)

When the "Start/End Recording" button on the data log function screen is touched, the data log function starts and data is stored in the internal memory of the touch panel display.

After 250 entries of sampling data are stored, the stored data will be written to the USB device.

Trend data will be recorded and saved to the USB device as a CSV file.

The data will be written when: 1) 250 entries of sampling data are stored, or 2) the "Start/Stop Recording" button is touched.

If data recording continues after data is written, or when the data log function is restarted, data will continue to be written to the same CSV file.
(Data will be overwritten and appended.)

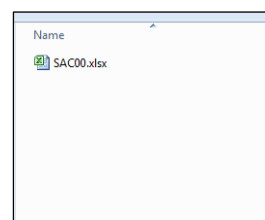
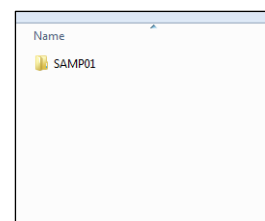

Figure:
Example of stored file

(3) Example of recorded data

The data written in the CSV file is recorded as in the figure below.

The upper limit of the collected data is dependent on the number of lines able to be displayed by the browsing/editing software.

If the number of data exceeds the maximum number of lines of the browsing/editing software, there is a possibility that the file may not be opened.

Once the data in the USB device is retrieved, make sure to delete files and folders on the USB device that have been automatically generated.

(If the data is not deleted, there is a possibility that new data will not be written as the automatic recording does not function if the USB device is used for the next record.)

	A	B	C	D	E	F	G	H	I
	Date	Time	OutletTemp(PV)	OutletTemp(SV)	ValveOpening(%)				
2	2017/1/17	14:40:26	61.9	65	4.5				
3	2017/1/17	14:40:27	61.9	65	4.8				
4	2017/1/17	14:40:28	62.1	65	5				
5	2017/1/17	14:40:29	62.4	65	5.1				
6	2017/1/17	14:40:30	62.9	65	4.8				
7	2017/1/17	14:40:31	63.7	65	4.5				
8	2017/1/17	14:40:32	64.4	65	3				
9	2017/1/17	14:40:33	65.2	65	2.5				
10	2017/1/17	14:40:34	65.8	65	2.7				
11	2017/1/17	14:40:35	66.4	65	2.1				
12	2017/1/17	14:40:36	67.1	65	15				
13	2017/1/17	14:40:37	67.4	65	0.9				
14	2017/1/17	14:40:38	67.5	65	0.6				
15	2017/1/17	14:40:39	67.3	65	0.5				
16	2017/1/17	14:40:40	66.7	65	2.4				
17	2017/1/17	14:40:41	66	65	1				
18	2017/1/17	14:40:42	65.5	65	2.4				
19	2017/1/17	14:40:43	65	65	1.9				
20	2017/1/17	14:40:44	64.5	65	2.4				
21	2017/1/17	14:40:45	64.1	65	3.6				
22	2017/1/17	14:40:46	63.9	65	3				
23	2017/1/17	14:40:47	63.6	65	4.3				
24	2017/1/17	14:40:48	63.5	65	3.6				
25	2017/1/17	14:40:49	63.6	65	2.9				
26	2017/1/17	14:40:50	63.6	65	3.9				
27	2017/1/17	14:40:51	64.1	65	3.6				
28	2017/1/17	14:40:52	64.6	65	1.6				
29	2017/1/17	14:40:53	65.3	65	2.9				
30	2017/1/17	14:40:54	65.8	65	1.4				
31	2017/1/17	14:40:55	66.4	65	0.8				
32	2017/1/17	14:40:56	67	65	1				
33	2017/1/17	14:40:57	67.2	65	0.6				
34	2017/1/17	14:40:58	67.2	65	0.3				
35	2017/1/17	14:40:59	66.9	65	1.3				
36	2017/1/17	14:41:00	66.5	65	1.4				

Figure: Example of recorded data

NOTE: The above figure is an example of when the data is viewed with Microsoft Excel (Microsoft Corporation). Microsoft Excel and Microsoft Corporation are registered trademarks or trademarks.



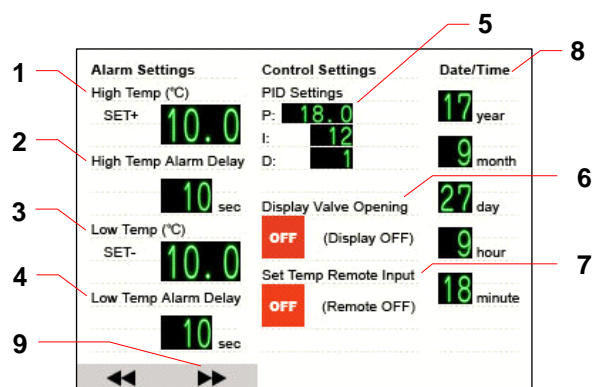

Parameter Settings Screen



Parameter Settings Screen (1)

No.	Function	Description
1	High Temp (°C)	<p>Sets the temperature at which the high temperature alarm is triggered.</p> <ul style="list-style-type: none"> • Defined as: Input value + set temperature = high temperature alarm value (When the temperature is set to 70 °C and upper limit alarm set temperature is set to 10 °C, the high temperature alarm value becomes 80 °C.) • When the water temperature falls below the alarm value during an active alarm, the unit will recover from the alarm status. • Factory setting: 10 °C
2	High Temp Alarm Delay	<p>Sets the alarm delay time for the high temperature alarm.</p> <ul style="list-style-type: none"> • When the water temperature exceeds the value set in No. 1 (High Temp) for a longer time period than set in No. 2, a high temperature alarm will be triggered. (When the high temperature alarm value is set to 80 °C and alarm delay is set to 10 seconds, an alarm will be triggered if the water temperature exceeds 80 °C for more than 10 seconds.) • When the temperature falls below the high temperature alarm value within the set alarm delay time, an high temperature alarm will not be triggered. • Factory setting: 10 seconds
3	Low Temp (°C)	<p>Sets the temperature at which the low temperature alarm is triggered.</p> <ul style="list-style-type: none"> • Defined as: Set temperature – input value = low temperature alarm value. (When the temperature is set to 70 °C and the lower limit alarm set temperature is set to 10 °C, the low temperature alarm value becomes 60 °C.) • When the water temperature exceeds the alarm value during an active alarm, the unit will recover from the alarm status. • Factory setting: 10 °C

Continued on next page

No.	Function	Description
4	Low Temp Alarm Delay	<p>Sets the alarm delay time for the low temperature alarm.</p> <ul style="list-style-type: none"> When the water temperature falls below the value set in No. 3 (Low Temp.) for a longer time period than set in No. 4, a low temperature will be triggered. (When the low temperature alarm value is set to 60 °C and alarm delay is set to 10 seconds, an alarm will be triggered if the water temperature falls below 60 °C for more than 10 seconds.) When the temperature exceeds the low temperature alarm value within the set alarm delay time, the low temperature alarm will not be triggered. Factory setting: 10 seconds <p>NOTE: Low temperature alarms will not be triggered for approximately the first 2 minutes after starting initial steam supply (at commissioning).</p>
5	PID Settings	<p>Sets the PID value (a constant to determine the operation sensitivity of the control valve).</p> <ul style="list-style-type: none"> The value is adjusted at the time of factory inspection according to application, flow rate, and temperature rise range. When "shortened start-up time" or "overshoot prevention" are required, make sure to confirm site safety before changing the PID constant. <p>Unnecessarily changing the PID value may result in being unable to obtain the set water temperature or in some cases overheating.</p> <p>For adjusting the PID constant (value), contact TLV.</p>
6	Display Valve Opening Button	<p>Displays the valve opening information on the main screen.</p> <ul style="list-style-type: none"> Display state can be changed by touching the square button. <ul style="list-style-type: none">  : Displayed  : Not displayed
7	Set Temp. Remote Input Button	<p>Switches between the main screen and the signal input to set the temperature.</p> <ul style="list-style-type: none"> Set temperature can be adjusted via either setting on the main screen of the touch panel, or by a 4 to 20 mA signal from an external input. <ul style="list-style-type: none">  : Via remote signal input <p>NOTE: When there is no signal input, the set temperature becomes 0 °C.</p> <ul style="list-style-type: none">  : Via the main screen (touch panel) <ul style="list-style-type: none"> Do not switch the input mode to set temperature while the unit is in operation.
8	Date/Time	<p>Adjusts the time displayed on the touch panel.</p> <ul style="list-style-type: none"> The time displayed at the bottom right on the main screen can be adjusted. Time displayed in the touch panel is required to record an alarm occurring time and recovery time. Factory setting: Date/Time is set according to Japan Standard Time.
9	▶▶ (Schedule Setting screen) Button	<p>Displays the schedule settings screen (weekly timer).</p>

Schedule Settings Screen (Weekly Timer)

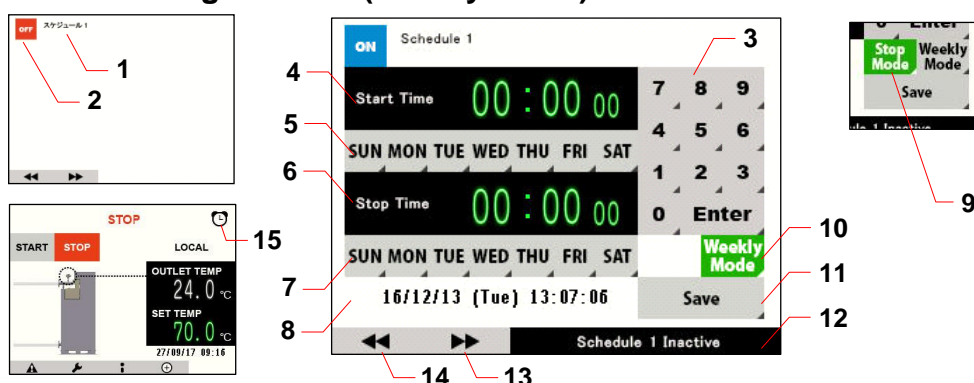

No.	Function	Description
1	Schedule No.	Displays the schedule number. • 3 (different) schedules can be set. (Schedule1/Schedule2/Schedule3)
2	ON/OFF Button (for the schedule function)	Activates/deactivates the schedule function. • Touching the ON button opens the settings screen. • Schedule function turns OFF when it is in the OFF mode. (Scheduled data will be saved.)
3	Numerical Keys	Inputs numerical values when setting date/time. • These keys are used to set Start Time and Stop Time. To input date/time: Input hour → touch "Enter" → input minute → touch "Enter" → input second → touch "Enter".
4	Start Time	The time to start the unit's automatic operation. • Touching the time displays an input screen with numerical keys.
5	Set the day to start operation	Sets the day to start operation. • Day buttons become green when pressed. Scheduled operation will be carried out on days displayed in green. (Automatic operation button switches on automatically.) • Multiple days can be selected. (Except days selected in "weekly mode", No. 10.) • Day buttons in green will be removed from the schedule if touched again.
6	Stop Time	The time to stop the unit's automatic operation • Touching the time displays an input screen with numerical keys. Touching the "Stop Time" button (no. 9) enables input.
7	Set the day to stop the operation	Sets the day to stop operation. • Day buttons become green when pressed. • Input enabled only in "weekly mode" (No. 10).
8	Current Time Display	Displays the current time. (YY/MM/DD (Day) hh:mm:ss)
9	Stop Time Button	Activates the settings for stop time (time when automatic operation is stopped). • Settings can be deactivated by touching this button again.
10	Mode Switch Button	Switches schedule mode between Daily Mode (described later) and Weekly Mode (described later). • When Weekly Mode is active, the button is displayed in green.
11	Save Button	Saves data after schedule data input. • Touching this button saves data. (Data will not be saved and will be deleted if navigating to another screen without touching this button.)
12	Status Display Bar	Displays the status of the scheduled timer. • Displays whether the unit is operating on a scheduled timer.

Continued on next page

No.	Function	Description
13	▶▶ (Displays the next schedule setting screen)	Displays the next schedule setting screen (1→2→3). <ul style="list-style-type: none"> • Touching this button displays the next schedule setting screen. • This button does not exist on the Schedule 3 setting screen.
14	Schedule setting display	This icon is displayed when the schedule function is ON. <ul style="list-style-type: none"> • This icon is displayed when Schedule 1, 2, or 3 are active.

1. How to set Daily Mode:

- (1) Make sure that Weekly Mode is inactive (the button is displayed in gray).
- (2) Touching any time value of Start Time enables input. Set values in the following order, touching Enter to confirm: Touch hour → Enter → minute → Enter → second.
- (3) Touch the days on which to set operation to start at the time input above. (See the figure to the right for an example of the schedule function set to Monday, Wednesday, and Friday).
- (4) When also setting Stop Time, touch the Weekly Mode button. This displays Stop Time and the Stop Time button becomes green. The input method is identical to the Start Time setting described above.
- (5) Finally, touch the Save button to save the settings. To deactivate the schedule function, touch the "ON/OFF" icon on the top left.

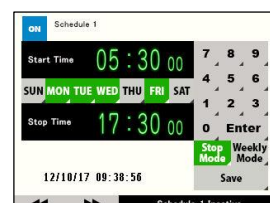
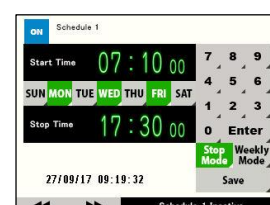
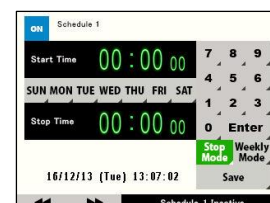

Input example:

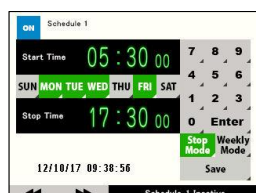

Automatic operation of the unit is turned ON at 7:10 on every Monday, Tuesday, Wednesday and Friday and OFF at 17:30 on the same day. (Will not operate on Sunday, Thursday and Saturday.)

2. How to set Weekly Mode:

- (1) Touch the Weekly Mode button to switch operation mode. (The button becomes green.)
- (2) Touching any time value of Start Time to set the time to start Weekly Mode.
- (3) Touch the day on which to set operation to start at the time input above.
- (4) Touching any time value of Stop Time to set the time to stop Weekly Mode.
- (5) Touch the day on which to stop the scheduled operation.
- (6) Finally, touch the Save button to save the settings. To deactivate the schedule function, touch the "ON/OFF" icon on the top left.



Input example:

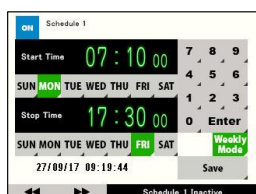

Automatic operation of the unit is turned ON at 7:10 on every Monday and OFF at 17:30 on every Friday of the same week. (After 7:10 on Monday, automatic operation is always ON on Tuesday, Wednesday, Thursday, Friday, and then (it will be) OFF at 17:30 on Friday.)

Safety Function (Abnormal Temperature Rise Preventing Function)

The safety function (abnormal temperature rise preventing function) activates when the water temperature exceeds, or is expected to exceed, the allowable upper limit temperature, in order to prevent an excessive temperature rise. This function activates under either of the following conditions 1. or 2.

1. When the water flow rate is below than the set flow rate*:

Below the set flow rate, the control valve (No. 11) is more likely to experience hunting (the valve is unable to control flow). As a result, not only will the water temperature become unobtainable, but there is the danger that the water temperature will rise suddenly.

The set flow rate of the unit varies depending on the usage conditions. Although the flow rate is set by the value stated in the 'product specification document' at the time of shipment, the approximate setting value per unit is approx. 2. to 4 m³/h.
2. When the water temperature exceeds the alarm value set at the High Temperature Alarm for the time set as the High Temp Alarm Delay or longer.
3. When the safety function is activated:
 - (1) The following actions are taken to prevent an abnormal temperature rise when under conditions described in 1. or 2. while the unit is in automatic operation:
 - a) Steam will be shut off:
The motorized valve (No. 12) of the steam supply unit and the control valve (No. 11) will close.
 - b) The cooling circulation system will start operation (when the cooling circulation unit (optional) is installed):
The solenoid valve (option: No. 7) of the cooling circulation unit opens and the circulating pump (option: No. 6) starts to operate. When the valves etc. on the hot water outlet line are shut off, the water discharged by the circulating pump will circulate the heat exchanger and water stored inside. When using water on the outlet side, the water discharged by the circulating pump will flow to the hot water outlet side and water as a priority.
 - (2) When both conditions 1. and 2. have been resolved, the motorized valve and control valve on the steam supply unit will recover (open), the solenoid valve on the cooling circulation unit will close, the circulating pump will stop (when the cooling circulation unit (optional) is installed) and the unit will return to normal automatic operation after the alarm delay time**.
4. When the safety function activates frequently:

It is assumed that the water flow rate is close to the set flow rate or the fluctuation is large. Either correct the system or consider measures to stabilize the water flow rate.

*The set flow rate of water is the minimum controllable flow rate for the unit under operating conditions. (Factory setting: see 'product specification document'.)

** Alarm delay time is the time required to reach stable flow after water begins to flow, or the time required for the circulating pump to operate to prevent overheating when the water flow stops. (Factory setting: 5 seconds).

Operation Flow

NOTE: For component names and numbers, refer to the unit/control panel configuration sections.

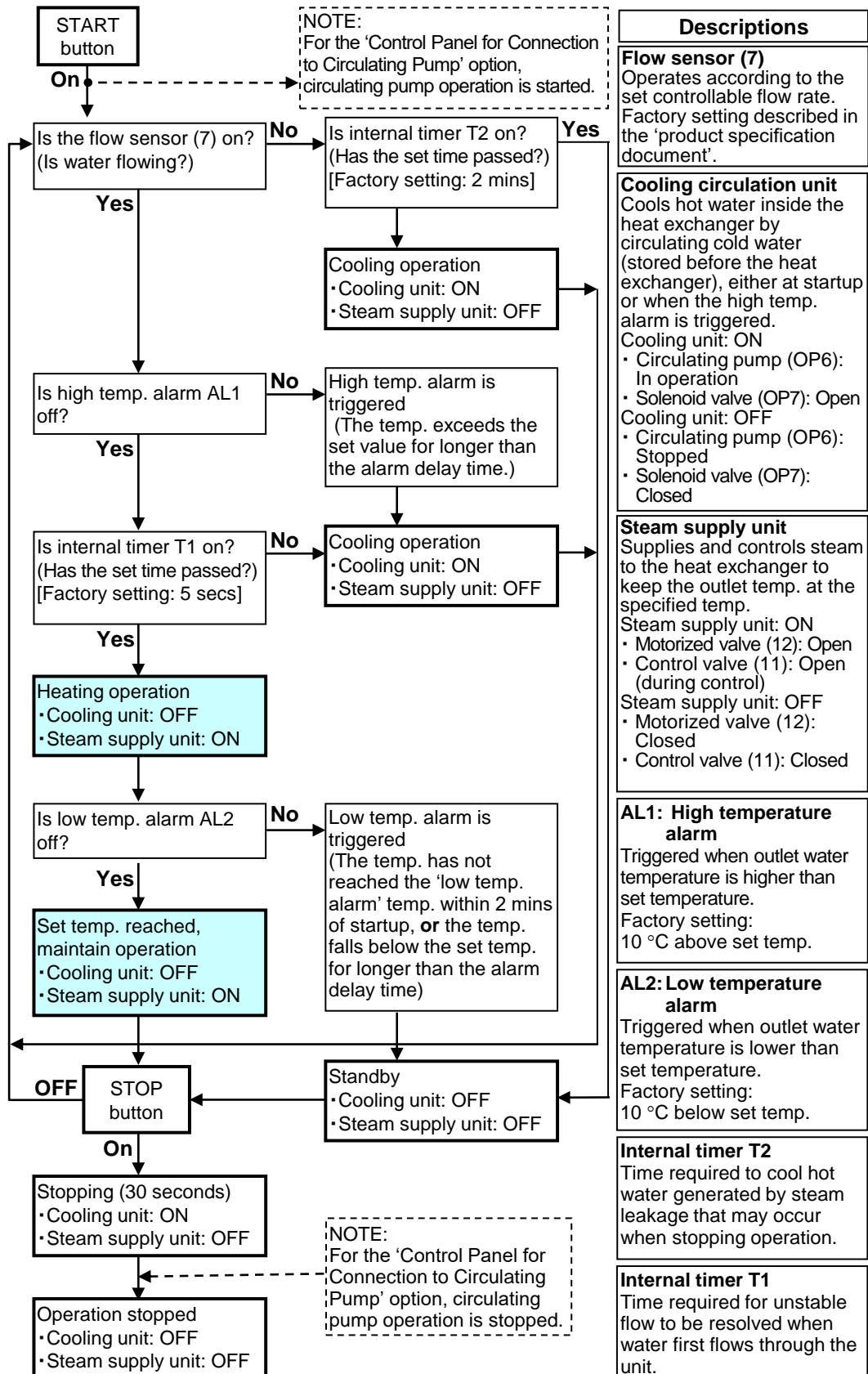

Descriptions
<p>Flow sensor (7) Operates according to the set controllable flow rate. Factory setting described in the 'product specification document'.</p>
<p>Cooling circulation unit Cools hot water inside the heat exchanger by circulating cold water (stored before the heat exchanger), either at startup or when the high temp. alarm is triggered. Cooling unit: ON • Circulating pump (OP6): In operation • Solenoid valve (OP7): Open Cooling unit: OFF • Circulating pump (OP6): Stopped • Solenoid valve (OP7): Closed</p>
<p>Steam supply unit Supplies and controls steam to the heat exchanger to keep the outlet temp. at the specified temp. Steam supply unit: ON • Motorized valve (12): Open • Control valve (11): Open (during control) Steam supply unit: OFF • Motorized valve (12): Closed • Control valve (11): Closed</p>
<p>AL1: High temperature alarm Triggered when outlet water temperature is higher than set temperature. Factory setting: 10 °C above set temp.</p>
<p>AL2: Low temperature alarm Triggered when outlet water temperature is lower than set temperature. Factory setting: 10 °C below set temp.</p>
<p>Internal timer T2 Time required to cool hot water generated by steam leakage that may occur when stopping operation.</p>
<p>Internal timer T1 Time required for unstable flow to be resolved when water first flows through the unit.</p>

Operation Procedure

Start-up

When operating the unit after a prolonged period of no operation, initial blowdown should be conducted on the steam and water piping preceding the unit.

Initial blowdown refers to the removal of residual condensate from steam piping and rusty water from water piping.

If blowdown is not conducted, problems such as water hammer in the steam piping and red water discharge in the water piping may occur. For details, refer to the "Commissioning" section in the "Installation/Commissioning" chapter.

To operate the unit, perform 1. and 2. described below.

Refer to the "Configuration (Component Name and Function)" section for the names of components.

1. Prior confirmation

- (1) Make sure that the condensate blowdown valve (No. 5) on the PowerTrap unit is closed.

In cold climates, valves may be mistakenly left open after condensate removal, in order to prevent freezing. Mistakenly leaving the valve open is dangerous, as steam or condensate may be discharged during operation start-up.



- (2) Make sure that the power supply indicator on the control panel is lit and the power is supplied to the control panel. When the power supply indicator is not lit, power may not be supplied to the control panel. Contact an electrician.

(Electrical layouts of the control panel shown in the right picture may differ from the actual layout.)



- (3) Make sure that the operational status is STOP.
 (4) Make sure that the steam is supplied up until the steam inlet valve and the steam pressure does not exceed 0.4 MPaG which is the maximum operating pressure for the unit.

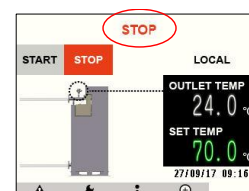

- (5) Make sure that the air pressure specified below is supplied to the positioner of the control valve (No. 11). When the air pressure has not reached the specified value, set the pressure to the specified value by turning the regulator handle. (Set pressure: 0.38 MPaG)
 For the electric proportional control valve, there is no air regulator, therefore this step is unnecessary.

When adjusting the air pressure, lift up the regulator handle until the orange sticker is visible, then turn the handle.



2. Operation

(1) Operation of the steam inlet valve

Open the steam inlet valve (No. 9) as slowly as possible.

Make sure that condensate is discharged from the condensate outlet of the condensate separator (No. 10) and the value indicated on the pressure gauge (No. 19) is stable at the predetermined value (recommended value: 0.2 to 0.4 MPaG.)

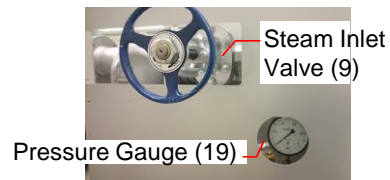

(2) Stand-by operation (STARTING UP...)

- Touch START button on the display.
- Even if the START button is touched, steam will not flow unless water is flowing. If water is already flowing at a temperature above the set temperature, (4) is the next step.

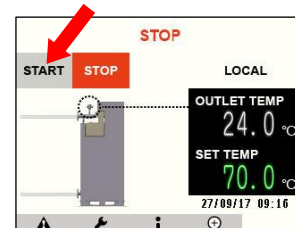

(3) Operation of the water supply valve

Open the valve (not included with the unit) on the water supply system.

(4) Starting unit operation

When the water reaches or exceeds the set flow rate¹⁾, the flow sensor (No. 7) senses the water flow in the unit to start the operation after the standby time of 5 seconds^{2) 3)}.

The solenoid valve (No. 11) opens and the condensate separator (No. 10) adjusts the steam flow rate.

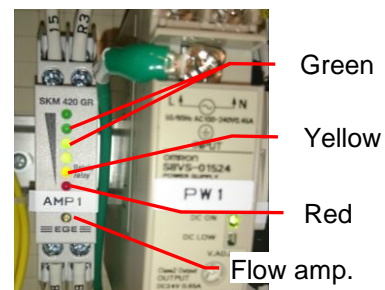

The time required for the water to reach the set temperature is approximately 1 to 4 minutes, depending on the operating conditions.

¹⁾ The set flow rate of water is the minimum controllable flow rate for the unit under operating conditions. (Factory setting: see 'product specification document'.) The set flow rate can be verified in the flow sensor set value on the parameter settings screen (2) in the touch panel.

²⁾ Alarm delay time is the time required to reach stable flow after water begins to flow, or the time required for the cooling circulation unit to operate to prevent overheating when the water flow stops. (Factory setting: 5 seconds).

³⁾ If the flow does not stabilize within 5 seconds and the unit repeatedly starts and stops operation, the alarm delay time must be changed. (Contact TLV for details of how to change the alarm delay time).

(5) Water temperature

The difference between the target temperature and the water temperature is normally ± 1 °C, depending on the operating conditions.

When the temperature difference is 3 °C or more, or when the water temperature fluctuates, it is likely that the water flow rate is also fluctuating greatly or is below/around the controllable flow rate. In such cases, contact the facility manager.

Details of how to check the water flow rate can be found in the "Commissioning Procedure" section of the "Installation/Commissioning" chapter.

(6) Adjusting the set temperature



Do not change the temperature setting without contacting the user when washing hands, using a shower or cleaning.
Failure to do so may result in burns to the user.

Touch the "Set Temperature Adjustment" button on the touch panel, and using the keyboard panel, input the desired temperature. (The temperature can be set up to 95 °C.)

Adjustment of the target temperature should be carried out when the water flow rate is stable or when operation is stopped.

Do not drastically reduce the set temperature from a high temperature to a lower temperature when using hot water continuously while the unit is in operation.

Even after the upper limit alarm delay time (factory setting: 10 seconds) has expired, any temperature difference that exceeds the upper limit set temperature alarm value (factory setting: 10 °C) will cause the high temperature alarm to be triggered, causing the unit to immediately stop operation.

Even if the target temperature is set within the operational range (30 to 95 °C), the temperature may be outside the capability range shown below depending on the temperature and flow rate conditions. In such cases, consult the facility manager, as it may be necessary to adjust other parameters such as the water flow rate.

(The thermal capability range of the SQ10 is 120 to 1200 kW. Even within this range, there are cases where the same phenomenon may occur depending on the temperature and flow rate conditions.)

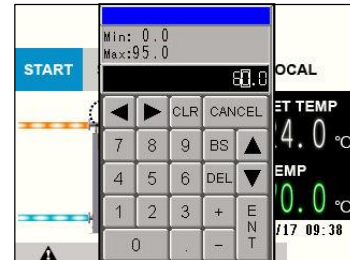

(7) External input of the target temperature

Refer to the "Touch Panel Display" section to adjust the target temperature.

Do not switch the input mode to set the temperature while the unit is in operation.

4 to 20 mA signal

Adjust the output range so that the input signal has the following settings.

4 mA = 0 °C → 20 mA = 100 °C

NOTE: Depending on the external environment, discrepancies may occur in the relationship between the current value and the set temperature value.

Shutdown

	<p>When finishing operation, the operation should be stopped in accordance with the proper steps.</p> <p>Incorrect operation of the unit during use for hand washing, showering, or cleaning, etc., may result in burns due to malfunction, which causes the temperature of the water to rise above the set temperature.</p>
	<p>When the unit is shut down for a long period of time or there is a possibility of freezing, make sure to completely discharge steam condensate or water in the unit and its components such as the steam piping, heat exchanger, etc.</p> <p>After doing so, there is a risk of burns or injury during operation start-up, as fluid may be discharged from piping.</p>

Make sure that hot water is not being used at the intended location for use.

1. Close the steam inlet valve (No. 9) slowly.

When the STOP button is touched on the touch panel without closing the steam inlet valve, the following conditions may be caused by the steam flow suddenly stopping:

- The steam source pressure temporarily rises and the safety valve (relief valve) (not included with the unit) installed on the pipe before the steam inlet valve activates.
- Supply pressure to other steam-using equipment becomes unstable.

If there are no such conditions likely to occur, touch the STOP button to stop operation. (Continue to Step 3.)

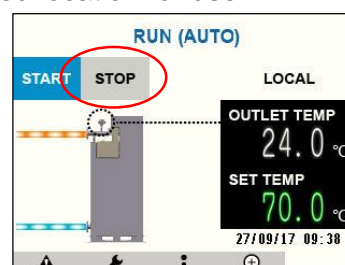

2. Confirm that the indicated value on the pressure gauge (No. 19) is at "0" and that no residual steam pressure is applied to the unit.

3. Touch the STOP button.

The solenoid valve (No. 12) and the control valve (No. 11) close. When the cooling circulation unit (optional) is installed, the solenoid valve (Option: No. 7) opens and the circulating pump (Option: No. 6) operates.

At this time, "STOPPING..." is displayed on the touch panel.

(The time required for operation to stop is approx. 30 seconds.)

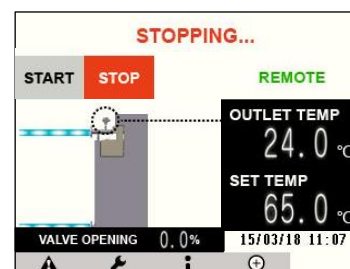

4. When the process to stop operation is complete, the unit's internal systems have fully stopped. Make sure that "STOP" is displayed on the touch panel and all components in the unit (except touch panel and sensors) have stopped.

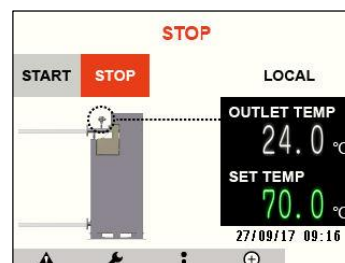

5. Close the valve (not included in the unit) on the water supply system to stop supplying water to the unit.

Prevention of Damage due to Freezing

 CAUTION	<p>When draining water from the unit, make sure to wait until the unit has cooled down.</p> <p>If carrying out work after hot water use, there is a risk of burns, as the components and the water inside the unit are hot.</p>
--	---

Make sure measures are taken to prevent freezing of the unit's steam piping system in cold climates. If the unit is damaged due to freezing, repair will be charged even within the warranty period.

Water in the water supply system cannot be discharged with the unit. To prevent freezing of water supply system, contact the administrator of the water system.

Draining procedure

1. Make sure that the steam inlet valve (No. 9) is closed and the unit has completely stopped and cooled down.
2. Open the condensate blow valve (No. 5) of the PowerTrap unit to discharge steam condensate.
3. Make sure to close the valve after confirming the steam condensate has been drained completely.
Mistakenly leaving the valve open is dangerous, as steam or condensate may be discharged during operation start-up.



Maintenance and Inspection

	<p>When disassembling or removing the unit and its components, wait until the internal pressure equals atmospheric pressure and the surface of the components have cooled to room temperature. Disassembling or removing components when hot or under pressure may lead to discharge of fluids, causing burns, other injuries or damage.</p>
	<p>When conducting an inspection during operation of the unit, it should be carried out visually wearing protective glasses, being careful not to touch the piping, etc. Failure to do so may result in burns, as the piping and cover of the unit become hot during operation.</p>
	<p>Take measures to prevent people coming into direct contact with the condensate outlet of the unit. Failure to do so may result in burns or other injury from the discharge of fluids.</p>
	<p>Be sure to use only the recommended components when repairing the unit, and NEVER attempt to modify the unit in any way. Failure to observe these precautions may result in a damage to the unit or burns or other injury due to malfunction or the discharge of fluids.</p>
	<p>Make sure the power switch is OFF before carrying out work on the wiring or inspections involving disassembly. If such work is carried out with the power on, there is a danger that unit may malfunction or electric shock may occur, leading to injury or other accidents.</p>
	<p>Make sure that wiring work requiring a special license is carried out by qualified personnel. If carried out by unqualified personnel, overheating or short circuits leading to injury, fires, damage or other accidents may occur.</p>

There are two types of inspection to be carried out for maintenance of the unit, daily inspections and periodic inspections.

- Daily inspection: Check visually and by sounds from the unit to judge for abnormal conditions.
- Periodic inspection: Skilled maintenance personnel should carry out disassembly of the necessary components for inspection.

1. Daily inspection

For trouble-free use of the unit, please check and record the following items on a daily basis.

If inspecting the back of the unit, make sure to wear appropriate safety gear (helmet, safety shoes, gloves etc.) and be careful of hot piping.

(1) Water/steam leakage

Check for any traces of leakage from valves, flanges or pipe fittings during operation.

(2) Pressure gauge (No. 19)

If the facility manager has indicated the acceptable pressure range on the pressure gauge, check that the pressure is within the range.



- (3) Air pressure of the positioner for the steam control valve

If the facility manager has indicated the acceptable pressure range on the pressure gauge, check that the pressure is within the range.



The set value of the pressure gauge is 0.38 MPaG, marked in green on the upper part on the proper value scale.

(If the air pressure value has deviated from the set value, make sure to correct the value.)

- (4) Filter regulator for the steam control valve

Check and make sure that condensate is not accumulated in the mist separator of the filter regulator. If condensate has accumulated, turn the plug at the bottom of the separator in the open direction to drain the condensate. After draining the condensate, make sure to close the plug by turning it in the closing direction.



NOTE: If using a mini air compressor to supply air, make sure to drain condensate from the compressor periodically.

- (5) Valve opening of the steam control valve (No. 11)

If the facility manager has indicated the acceptable pressure range on the pressure gauge, check that the pressure is within the range.

- (6) Abnormal sounds/vibrations

Check for any sounds or vibrations from inside the unit, such as steam or water flow, or sounds or vibrations from the circulating pump or valve motors etc. that are clearly different from normal.



- (7) Closing the condensate blow valve (No. 5)

Check to make sure that the valve is closed after condensate blowdown is carried out. If the condensate blow valve is not closed, it is dangerous as steam will blow out when operation starts.

2. Periodic inspection

As a general rule, periodic inspection should be carried out once every two years.

- (1) For maintenance of the following components, refer to individual instruction manuals. Instruction manuals can be requested from TLV or accessed from the TLV website.
- PowerTrap (GT14L)
 - Steam inlet valve (bellows valve) (BE6H)
 - Cyclone separator trap (DC3S)
 - Control Valve (CV10)
 - Electro-pneumatic positioner for control valve CV10
 - Check valve, steam trap, air vent for steam, ball valve

(2) Temperature sensor (No. 8)

- a) Check for build-up on the temperature sensor protection tube and remove if necessary. Remove the temperature sensor and check the surface of the protection tube at the tip of the sensor.



- b) Calibration of the temperature sensor

If there is any doubt about the temperature indication value, request a calibration inspection by TLV or the sensor manufacturer.

(3) Flow sensor (No. 7)

- a) Check and remove deposits on the probe
When removing the flow sensor from the piping, make sure that the wiring is disconnected. Handle the flow sensor carefully as it may break if it is dropped or subjected to impact. Use a soft cloth to wipe off foreign matter adhered to the probe at the tip of the flow sensor. Be careful not to damage the probe.



- b) Operational check

- Quick check

If it is possible to reduce or stop the water supply, the operational status can be verified by checking whether water is being supplied and "flow sensor present value" is displayed.

- Calibration check

Request a calibration inspection by TLV or the flow sensor manufacturer.

(4) Circulating pump (Option: No. 6)/solenoid valve (Option: No. 7) (when the cooling circulation unit (optional) is installed)

The circulating pump operates when supply water is stopped (still in operation) or while stopping operation.

The circulating pump and solenoid valve can be confirmed to be operating correctly if vibration due to water flow can be felt when touching the pump or valve piping.

When touching the inner piping of the pump, take care to avoid burns, as the piping may be hot.

Even if the water supply valve on the water system side (not included with the unit) is closed, an operational check can be performed, as the circulating pump still operates on the heat exchanger (No. 6).



3. Consumable parts and their estimated replacement timing.

Refer to the table below for the estimated replacement timing for consumable parts.

Part	Estimated Timing for replacement
Pressure Gauge	Periodically, when the indicated value is incorrect, or "0" is not indicated in the atmospheric pressure
Valve Seat of the Solenoid Valve (cooling circulation unit (optional))	When liquid leaks, or every 100,000 opening/closing operations
Gaskets	When liquid leaks, or when the unit is disassembled

NOTE: For details regarding maintenance and inspection of each part, refer to respective instruction manuals.

Storage

The openings of the unit are sealed with a label, plastic sheet, etc., and delivered after taking measures to prevent rust and contamination.

Observe the storage instructions until the unit is installed on the piping. If the following storage instructions cannot be observed, rust or foreign matter may void the warranty.

Storage Instructions

- (1) Store the unit indoors to prevent it from getting wet by rainwater, dew, etc.
- (2) Store the unit in a place where the humidity is 80% or less.
- (3) If the label or plastic sheet used for sealing or packaging of the unit is damaged, replace it immediately or repair it with appropriate tape to maintain the seal.
- (4) When repacking the unit, pack it with cushioning material so that it does not fall or collide when moving or transporting.
- (5) If the unit is stored for a long period of time (approx. six months or more), unpack it at intervals of 6 months or less to check visually for rust and foreign matter. If an antirust agent is used, replace it with a new one of the same amount. After no abnormalities are confirmed, seal the opening as it was.
- (6) Remove labels, plastic sheets, etc. sealing the opening just before installing the unit.

Troubleshooting

 CAUTION	<p>In case of an abnormality, install a safety fence or restrict access to the room with a sign stating “Authorized personnel only.” etc. to prevent personnel unauthorized for the unit (including those who have not received the relevant safety education) touching the components. When doing so, stop the supply or steam, electrical power, water and air.</p> <p>Failure to prevent the access of unauthorized personnel may result in burns, electric shock, injury, or falls.</p>
--	---

If the unit fails to operate properly, use the following table to locate the cause and remedy.

If it is not possible to resolve the problem even after carrying out the remedy below, contact TLV.

Problem	Cause	Diagnosis	Remedy
The display does not light up	Power is not supplied.	Check the power supply indicator.	Supply power to the control panel at the specified voltage of 100V AC or 200 V AC.
Operation does not start after touching the START button	5 seconds have not passed after starting operation.		Wait for 5 seconds.
	The water supply system valve is closed. The flow rate is below the required amount.	Operation check of the flow sensor: Check the water flow on the touch panel	Open the valve. Increase the water amount.
	5 seconds have not passed after AL1 triggered.	Check the high temperature alarm on the touch panel.	Wait until AL1 is resolved. Investigate the cause for AL1 to be triggered.
	Temperature sensor is broken.	Check that the outlet temperature on the touch panel is displayed as "0".	Replace with a new temperature sensor.
	Air is not supplied to the control valve.	Check the pressure of the regulator.	Supply the required air pressure.
	The sequencer is faulty.	An error message appears on the touch panel.	Replace the internal sequencer.
Temperature does not rise as prescribed	Steam supply pressure is reduced or insufficient steam amount.	Check the settings for the pressure reducing valve (not included with the unit).	Set to the maximum steam pressure possible to be supplied below 0.4 MPaG.
		Check the steam main valve.	Open the main valve.
		Check for clogging in piping.	Remove the clog.
		Check the pressure loss of the piping.	Make sure a steam supply pressure of 0.4 MPaG is obtainable up until the unit.
	Air supply pressure to the control valve is low.	Check the air supply pressure to the control valve.	Supply the required air pressure.

Problem	Cause	Diagnosis	Remedy
Water temperature is unstable	Large fluctuations in amount of water used.	Check the operating conditions.	Reduce sudden changes in the amount of water used. (Refer to the "Temperature Stability" area of this section.)
	Inlet steam pressure of the control valve is unstable.	Check the steam pressure.	Make sure a steam supply pressure of 0.4 MPaG is obtainable up until the unit.
	Air supply pressure to the control valve is unstable.	Check the air supply pressure to the control valve.	Supply required pressure.
	Build-up or wear in the control valve or valve seats.	Check the closing sound of the control valve at a temperature below the set temperature.	Maintenance is necessary when a high-pitched steam flow sound can be heard.
	The PID is not appropriate.	Check the PID.	Change the PID to a proper value.
Abnormal system alarm 1 is triggered	One or more of the following 4 malfunctions are occurring: 1. Malfunction of the internal sequencer parts 2. The temperature sensor is broken 3. Wiring between the sensor and sequencer is disconnected 4. Wiring for measured temp. value output is disconnected or a problem has occurred at the output location. (When using measured temp. value output)	Follow the steps below to resolve problems. (1) When using measured temp. value output, disconnect the wiring and connect it to a 250 Ω resistor. (2) Confirm continuity between the temperature sensor and the sequencer. (3) Replace the temperature sensor with a working sensor, then reconfirm the continuity between the temperature sensor and the sequencer.	If the alarm is resolved when implementing diagnosis (1), cause 4. is likely to be the problem. Correct the output location and wiring. If continuity between the temperature sensor and the sequencer cannot be confirmed for diagnosis (2), cause 3. is likely to be the problem. Replace the wiring. If the alarm is resolved when implementing diagnosis (3), cause 2. is likely to be the problem. Replace with a new temperature sensor. If the alarm is not resolved after implementing diagnoses (1) to (3), cause 1. is likely to be the problem. Replace the sequencer.
Abnormal system alarm 2 is triggered	Malfunction of the internal sequencer parts.		Replace the sequencer.
	Malfunction of the control valve or the solenoid valve of the steam supply unit.	Confirm the valve opening and the temperature of the piping before and after the control valve or the solenoid valve of the steam supply unit.	Replace the valve with a large temperature difference in the piping before/after the valve.

NOTE: Refer to individual instruction manuals for problems with other components.

Service or Technical Assistance

For Service or Technical Assistance: Contact your TLV representative or your TLV office.

In Europe:

TLV EURO ENGINEERING GmbH

Daimler-Benz-Straße 16-18, 74915 Waibstadt, **Germany**

Tel: [49]-(0)7263-9150-0
Fax: [49]-(0)7263-9150-50

TLV EURO ENGINEERING UK LTD.

Star Lodge, Montpellier Drive, Cheltenham, Gloucestershire, GL50 1TY, **U.K.**

Tel: [44]-(0)1242-227223
Fax: [44]-(0)1242-223077

TLV EURO ENGINEERING FRANCE SARL

Parc d'Ariane 2, bât. C, 290 rue Ferdinand Perrier, 69800 Saint Priest, **France**

Tel: [33]-(0)4-72482222
Fax: [33]-(0)4-72482220

In North America:

TLV CORPORATION

13901 South Lakes Drive, Charlotte, NC 28273-6790, **U.S.A.**

Tel: [1]-704-597-9070
Fax: [1]-704-583-1610

In Mexico and Latin America:

TLV ENGINEERING S. A. DE C. V.

Av. Jesús del Monte 39-B-1001, Col. Hda. de las Palmas, Huixquilucan, Edo. de México, 52763, **Mexico**

Tel: [52]-55-5359-7949
Fax: [52]-55-5359-7585

In Oceania:

TLV PTY LIMITED

Unit 8, 137-145 Rooks Road, Nunawading, Victoria 3131, **Australia**

Tel: [61]-(0)3-9873 5610
Fax: [61]-(0)3-9873 5010

In East Asia:

TLV PTE LTD

36 Kaki Bukit Place, #02-01/02, **Singapore** 416214

Tel: [65]-6747 4600
Fax: [65]-6742 0345

TLV SHANGHAI CO., LTD.

Room 5406, No. 103 Cao Bao Road, Shanghai, **China** 200233

Tel: [86]-(0)21-6482-8622
Fax: [86]-(0)21-6482-8623

TLV ENGINEERING SDN. BHD.

No.16, Jalan MJ14, Taman Industri Meranti Jaya, 47120 Puchong, Selangor, **Malaysia**

Tel: [60]-3-8065-2928
Fax: [60]-3-8065-2923

TLV PRIVATE LIMITED

252/94 (K-L) 17th Floor, Muang Thai-Phatra Complex Tower B, Rachadaphisek Road, Huaykwang, Bangkok 10310, **Thailand**

Tel: [66]-2693-3799
Fax: [66]-2693-3979

TLV INC.

#302-1 Bundang Technopark B, 723 Pangyo-ro, Bundang, Seongnam, Gyeonggi, 13511, **Korea**

Tel: [82]-(0)3-8052-2928
Fax: [82]-(0)3-8051-0899

In the Middle East:

TLV ENGINEERING FZCO

Building 6WA, Office No. 629, PO Box 371684, Dubai Airport Free Zone, Dubai, **UAE**

Tel: [82]-(0)31-726-2105
Fax: [82]-(0)31-726-2195

In Other Countries:

TLV INTERNATIONAL, INC.

881 Nagasuna, Noguchi, Kakogawa, Hyogo 675-8511, **Japan**

Tel: [81]-(0)79-427-1818
Fax: [81]-(0)79-425-1167

Manufacturer:

TLV CO., LTD.

881 Nagasuna, Noguchi, Kakogawa, Hyogo 675-8511, **Japan**

Tel: [81]-(0)79-422-1122
Fax: [81]-(0)79-422-0112

Specifications

	Install properly and DO NOT use the unit outside the recommended operating pressure, temperature and other specification ranges. Improper use may result in such hazards as damage to the unit or malfunctions that may lead to serious accidents. Local regulations may restrict the use of the unit to below the conditions quoted.
---	---

Specifications of the unit are subject to change without notice for improvement.

Model		SQ10	
Thermal Capability Class (No.)	kW	1000	
Heating Method		Steam/water shell & spiral tube indirect heating	
Applicable Hot Water Supply Piping		Single pass/Recirculating (Separate equipment required for circulating pump piping)	
Water Piping Material		SUS304, SUS316, non-asbestos gaskets etc. Compliant with Water Supply Act (in Japan)	
Steam Piping Material		STPG370, FC250, non-asbestos gaskets etc.	
Power Source AC single phase		100 V AC 50/60 Hz or 200 V AC 50/60 Hz	
Temp. Setting Range	°C	30 to 95 °C	
Allowable Temperature for Cold/Hot Water Areas	°C	Cold water side: 70 °C Hot water side: 110 °C	
Heat Exchanger PMA/TMA	MPaG/°C	1.0 MPaG/185 °C	
Maximum Operating Steam Pressure	MPaG	0.4	
Motive Air Supply Pressure for Control Valve	MPaG	0.38	
Temperature Rise Preventing Function		Cooling circulation system featuring steam inlet solenoid valve and circulating pump	
Connections	Cold/Hot Water Inlet/Outlet	mm	65/65 JIS10KFF
	Steam Inlet	mm	65 JIS10KFF
	Condensate Outlet	mm	40 JIS10KFF
Installation Location		Indoors	

(1 MPa = 10.197 kg/cm²)

Maximum Allowable Pressure (PMA) and Maximum Allowable Temperature (TMA)
(Pressure shell design conditions, not operating conditions.)

- (1) Maximum Allowable Pressure (PMA): The maximum allowable pressure for pressurized parts.
 - Steam piping system: 1.0 MPaG
 - Water piping system: 1.0 MPaG
- (2) Maximum Allowable Temperature (TMA): The maximum allowable temperature for pressurized parts.
 - Steam piping system: 185 °C
 - Water piping system: Cold water side: 70 °C/Hot water side: 110 °C

Disposal of the Unit

	When disposing of this unit, disassemble and sort components in a way that adheres to local regulations, while considering environmental conservation, recycling and the pollution prevention.
---	---

TLV EXPRESS LIMITED WARRANTY

Subject to the limitations set forth below, TLV CO., LTD., a Japanese corporation (“**TLV**”), warrants that products which are sold by it, TLV International Inc. (“**TII**”) or one of its group companies excluding TLV Corporation (a corporation of the United States of America), (hereinafter the “**Products**”) are designed and manufactured by TLV, conform to the specifications published by TLV for the corresponding part numbers (the “**Specifications**”) and are free from defective workmanship and materials. The party from whom the Products were purchased shall be known hereinafter as the “**Seller**”. With regard to products or components manufactured by unrelated third parties (the “**Components**”), TLV provides no warranty other than the warranty from the third party manufacturer(s), if any.

Exceptions to Warranty

This warranty does not cover defects or failures caused by:

1. improper shipping, installation, use, handling, etc., by persons other than TLV, TII or TLV group company personnel, or service representatives authorized by TLV; or
2. dirt, scale or rust, etc.; or
3. improper disassembly and reassembly, or inadequate inspection and maintenance by persons other than TLV or TLV group company personnel, or service representatives authorized by TLV; or
4. disasters or forces of nature or Acts of God; or
5. abuse, abnormal use, accidents or any other cause beyond the control of TLV, TII or TLV group companies; or
6. improper storage, maintenance or repair; or
7. operation of the Products not in accordance with instructions issued with the Products or with accepted industry practices; or
8. use for a purpose or in a manner for which the Products were not intended; or
9. use of the Products in a manner inconsistent with the Specifications; or
10. use of the Products with Hazardous Fluids (fluids other than steam, air, water, nitrogen, carbon dioxide and inert gases (helium, neon, argon, krypton, xenon and radon)); or
11. failure to follow the instructions contained in the TLV Instruction Manual for the Product.

Duration of Warranty

This warranty is effective for a period of one (1) year after delivery of Products to the first end user. Notwithstanding the foregoing, asserting a claim under this warranty must be brought within three (3) years after the date of delivery to the initial buyer if not sold initially to the first end user.

ANY IMPLIED WARRANTIES NOT NEGATED HEREBY WHICH MAY ARISE BY OPERATION OF LAW, INCLUDING THE IMPLIED WARRANTIES OF MERCHANTABILITY AND FITNESS FOR A PARTICULAR PURPOSE AND ANY EXPRESS WARRANTIES NOT NEGATED HEREBY, ARE GIVEN SOLELY TO THE INITIAL BUYER AND ARE LIMITED IN DURATION TO ONE (1) YEAR FROM THE DATE OF SHIPMENT BY THE SELLER.

Exclusive Remedy

THE EXCLUSIVE REMEDY UNDER THIS WARRANTY, UNDER ANY EXPRESS WARRANTY OR UNDER ANY IMPLIED WARRANTIES NOT NEGATED HEREBY (INCLUDING THE IMPLIED WARRANTIES OF MERCHANTABILITY AND FITNESS FOR A PARTICULAR PURPOSE), IS **REPLACEMENT**; PROVIDED: (a) THE CLAIMED DEFECT IS

REPORTED TO THE SELLER IN WRITING WITHIN THE WARRANTY PERIOD, INCLUDING A DETAILED WRITTEN DESCRIPTION OF THE CLAIMED DEFECT AND HOW AND WHEN THE CLAIMED DEFECTIVE PRODUCT WAS USED; AND (b) THE CLAIMED DEFECTIVE PRODUCT AND A COPY OF THE PURCHASE INVOICE IS RETURNED TO THE SELLER, FREIGHT AND TRANSPORTATION COSTS PREPAID, UNDER A RETURN MATERIAL AUTHORIZATION AND TRACKING NUMBER ISSUED BY THE SELLER. ALL LABOR COSTS, SHIPPING COSTS, AND TRANSPORTATION COSTS ASSOCIATED WITH THE RETURN OR REPLACEMENT OF THE CLAIMED DEFECTIVE PRODUCT ARE SOLELY THE RESPONSIBILITY OF BUYER OR THE FIRST END USER. THE SELLER RESERVES THE RIGHT TO INSPECT ON THE FIRST END USER'S SITE ANY PRODUCTS CLAIMED TO BE DEFECTIVE BEFORE ISSUING A RETURN MATERIAL AUTHORIZATION. SHOULD SUCH INSPECTION REVEAL, IN THE SELLER'S REASONABLE DISCRETION, THAT THE CLAIMED DEFECT IS NOT COVERED BY THIS WARRANTY, THE PARTY ASSERTING THIS WARRANTY SHALL PAY THE SELLER FOR THE TIME AND EXPENSES RELATED TO SUCH ON-SITE INSPECTION.

Exclusion of Consequential and Incidental Damages

IT IS SPECIFICALLY ACKNOWLEDGED THAT THIS WARRANTY, ANY OTHER EXPRESS WARRANTY NOT NEGATED HEREBY, AND ANY IMPLIED WARRANTY NOT NEGATED HEREBY, INCLUDING THE IMPLIED WARRANTIES OF MERCHANTABILITY AND FITNESS FOR A PARTICULAR PURPOSE, DO NOT COVER, AND NEITHER TLV, TII NOR ITS TLV GROUP COMPANIES WILL IN ANY EVENT BE LIABLE FOR, INCIDENTAL OR CONSEQUENTIAL DAMAGES, INCLUDING, BUT NOT LIMITED TO LOST PROFITS, THE COST OF DISASSEMBLY AND SHIPMENT OF THE DEFECTIVE PRODUCT, INJURY TO OTHER PROPERTY, DAMAGE TO BUYER'S OR THE FIRST END USER'S PRODUCT, DAMAGE TO BUYER'S OR THE FIRST END USER'S PROCESSES, LOSS OF USE, OR OTHER COMMERCIAL LOSSES. WHERE, DUE TO OPERATION OF LAW, CONSEQUENTIAL AND INCIDENTAL DAMAGES UNDER THIS WARRANTY, UNDER ANY OTHER EXPRESS WARRANTY NOT NEGATED HEREBY OR UNDER ANY IMPLIED WARRANTY NOT NEGATED HEREBY (INCLUDING THE IMPLIED WARRANTIES OF MERCHANTABILITY AND FITNESS FOR A PARTICULAR PURPOSE) CANNOT BE EXCLUDED, SUCH DAMAGES ARE EXPRESSLY LIMITED IN AMOUNT TO THE PURCHASE PRICE OF THE DEFECTIVE PRODUCT. THIS EXCLUSION OF CONSEQUENTIAL AND INCIDENTAL DAMAGES, AND THE PROVISION OF THIS WARRANTY LIMITING REMEDIES HEREUNDER TO REPLACEMENT, ARE INDEPENDENT PROVISIONS, AND ANY DETERMINATION THAT THE LIMITATION OF REMEDIES FAILS OF ITS ESSENTIAL PURPOSE OR ANY OTHER DETERMINATION THAT EITHER OF THE ABOVE REMEDIES IS UNENFORCEABLE, SHALL NOT BE CONSTRUED TO MAKE THE OTHER PROVISIONS UNENFORCEABLE.

Exclusion of Other Warranties

THIS WARRANTY IS IN LIEU OF ALL OTHER WARRANTIES, EXPRESS OR IMPLIED, AND ALL OTHER WARRANTIES, INCLUDING BUT NOT LIMITED TO THE IMPLIED WARRANTIES OF MERCHANTABILITY AND FITNESS FOR A PARTICULAR PURPOSE, ARE EXPRESSLY DISCLAIMED.

Severability

Any provision of this warranty which is invalid, prohibited or unenforceable in any jurisdiction shall, as to such jurisdiction, be ineffective to the extent of such invalidity, prohibition or unenforceability without invalidating the remaining provisions hereof, and any such invalidity, prohibition or unenforceability in any such jurisdiction shall not invalidate or render unenforceable such provision in any other jurisdiction.

Service

For Service or Technical Assistance: Contact your TLV representative or your TLV office.

In Europe:

TLV EURO ENGINEERING GmbH

Daimler-Benz-Straße 16-18, 74915 Waibstadt, **Germany**

Tel: [49]-(0)7263-9150-0

Fax: [49]-(0)7263-9150-50

TLV EURO ENGINEERING UK LTD.

Units 7 & 8, Furlong Business Park, Bishops Cleeve, Gloucestershire, GL52 8TW, **U.K.**

Tel: [44]-(0)1242-227223

Fax: [44]-(0)1242-223077

TLV EURO ENGINEERING FRANCE SARL

Parc d'Ariane 2, bât. C, 290 rue Ferdinand Perrier, 69800 Saint Priest, **France**

Tel: [33]-(0)4-72482222

Fax: [33]-(0)4-72482220

In North America:

TLV CORPORATION

13901 South Lakes Drive, Charlotte, NC 28273-6790, **U.S.A.**

Tel: [1]-704-597-9070

Fax: [1]-704-583-1610

In Mexico and Latin America:

TLV ENGINEERING S. A. DE C. V.

Av. Jesús del Monte 39-B-1001, Col. Hda. de las Palmas, Huixquilucan, Edo. de México, 52763, **Mexico**

Tel: [52]-55-5359-7949

Fax: [52]-55-5359-7585

In Oceania:

TLV PTY LIMITED

Unit 8, 137-145 Rooks Road, Nunawading, Victoria 3131, **Australia**

Tel: [61]-(0)3-9873 5610

Fax: [61]-(0)3-9873 5010

In East Asia:

TLV PTE LTD

36 Kaki Bukit Place, #02-01/02, **Singapore** 416214

Tel: [65]-6747 4600

Fax: [65]-6742 0345

TLV SHANGHAI CO., LTD.

Room 5406, No. 103 Cao Bao Road, Shanghai, **China** 200233

Tel: [86]-(0)21-6482-8622

Fax: [86]-(0)21-6482-8623

TLV ENGINEERING SDN. BHD.

No.16, Jalan MJ14, Taman Industri Meranti Jaya, 47120 Puchong, Selangor, **Malaysia**

Tel: [60]-3-8052-2928

Fax: [60]-3-8051-0899

TLV PRIVATE LIMITED

252/94 (K-L) 17th Floor, Muang Thai-Phatra Complex Tower B, Rachadaphisek Road, Huaykwang, Bangkok 10310, **Thailand**

Tel: [66]-2-693-3799

Fax: [66]-2-693-3979

TLV INC.

#302-1 Bundang Technopark B, 723 Pangyo-ro, Bundang, Seongnam, Gyeonggi, 13511, **Korea**

Tel: [82]-(0)31-726-2105

Fax: [82]-(0)31-726-2195

In the Middle East:

TLV ENGINEERING FZCO

Building 2W, No. M002, PO Box 371684, Dubai Airport Free Zone, Dubai, **UAE**

Email: sales-me@tlv.co.jp

In Other Countries:

TLV INTERNATIONAL, INC.

881 Nagasuna, Noguchi, Kakogawa, Hyogo 675-8511, **Japan**

Tel: [81]-(0)79-427-1818

Fax: [81]-(0)79-425-1167

Manufacturer:

TLV CO., LTD.

881 Nagasuna, Noguchi, Kakogawa, Hyogo 675-8511, **Japan**

Tel: [81]-(0)79-422-1122

Fax: [81]-(0)79-422-0112

Installation/Commissioning

Introduction

The unit has been certified by JET (Japan Electrical Safety & Environment Technology Laboratories) as a water supply instrument based on the Water Supply Act (in Japan).





Safety Considerations

Read this section carefully before installation and be sure to follow the instructions. Please keep this manual in a location where it is accessible at all times.

There is a space under the control panel of the unit for storage of this manual.

The precautions listed in this manual are designed to ensure safety and prevent equipment damage and personal injury. For situations that may occur as a result of erroneous handling, three different types of cautionary items are used to indicate the degree of urgency and the scale of potential damage and danger: DANGER, WARNING or CAUTION.

Symbols

	Indicates a DANGER, WARNING and CAUTION item.
	Indicates an urgent situation which poses a threat of death or serious injury
	Indicates that there is a potential threat of death or serious injury
	Indicates that there is a possibility of injury or equipment/product damage

Be sure to follow the instructions, as each contains important information regarding safety.

To use the unit correctly and safely, be sure to follow the safety considerations written in this manual when checking the unit's "Caution/Warning sticker", installing the unit and/or wiring, starting or stopping operation, or carrying out maintenance or repairs etc.

Furthermore, TLV CO., LTD. does not bear responsibility or guarantee the unit for damages or accidents that arise from not following these considerations.



Checking the "Caution/Warning Stickers"

"Caution/Warning stickers" can be found on both the unit and some components. The operator of this unit should understand what is written on the "Caution/Warning stickers" before operating the unit.

Precautions for the Entire Unit

 CAUTION	<p>Install properly and DO NOT use the unit outside the recommended operating pressure, temperature and other specification ranges. Improper use may result in such hazards as damage to the unit or malfunctions that may lead to serious accidents. Local regulations may restrict the use of the unit to below the conditions quoted.</p>
	<p>When the unit is directly connected to municipal water supply piping, back flow prevention measures must be taken in accordance with the Water Supply Act (in Japan). Failure to do so may lead to serious accidents in the water main line.</p>
	<p>Use hoisting equipment for heavy objects (weighing approximately 20 kg or more). Failure to do so may result in back strain or other injury if the object should fall.</p>
	<p>Take measures to prevent people from coming into direct contact with condensate discharge of the unit. Failure to do so may result in burns or other injury from the discharge of fluids.</p>
	<p>When disassembling or removing the unit and its components, wait until the internal pressure equals atmospheric pressure and the surface of the components have cooled to room temperature. Disassembling or removing components when hot or under pressure may lead to discharge of fluids, causing burns, other injuries or damage.</p>
	<p>Be sure to use only the recommended components when repairing the unit, and NEVER attempt to modify the unit in any way. Failure to observe these precautions may result in damage to the unit and burns or other injury due to malfunction or the discharge of fluids.</p>
	<p>Do not use excessive force when connecting threaded pipes to the unit. Over-tightening may cause breakage leading to fluid discharge, which may cause burns or other injury.</p>
	<p>Use only under conditions in which no freeze-up will occur. Freezing may damage the unit, leading to fluid discharge, which may cause burns or other injury.</p>
	<p>Use only under conditions in which no water hammer will occur. The impact of water hammer may damage the unit, leading to fluid discharge, which may cause burns or other injury.</p>
	<p>Make sure the power supply is OFF before carrying out work on the wiring or inspections involving disassembly. If such work is carried out with the power on, there is a danger that the unit may malfunction or electric shock may occur, leading to injury or other accidents.</p>
<p>Make sure that wiring work requiring a special license is carried out by qualified personnel. If carried out by unqualified personnel, overheating or short circuits leading to injury, fires, damage or other accidents may occur.</p>	

Precautions for Piping Installation

 WARNING	<p>For applications such as handwashing in which hot water directly touches hands, when using the one-pass method, make sure to install a thermostatic mixing valve on the outlet. Failure to observe this precaution may result in burns, as water at a temperature higher than the set temperature may flow due to load fluctuations.</p>
 CAUTION	<p>To use the unit safely and properly, read this instruction manual carefully to carry out the specified work. Installation, moving and incidental work of the unit requires professional qualifications and skills. The work should be carried out by a qualified personnel. Once installation is complete, make sure that the work is carried out based on the instruction manual. Work carried out improperly may lead to accidents or unit malfunction.</p> <p>Do not use well water or water from a hot spring. Depending on the water quality, foreign matter may adhere to, or corrosion may occur in, the unit piping, resulting in water leaks. In this case, there will be a charge for repair work even during the warranty period.</p> <p>Do not use excessive force when connecting threaded pipes to the unit. Over-tightening may cause breakage leading to the unit damage, fluid discharge during operation, injury, burns, etc.</p> <p>Make sure that work (such as transportation, installation, welding or wiring) requiring a special license is carried out by qualified personnel. Improper work may lead to falls, heat generation, injuries due to electrical leakage, fire or damage.</p> <p>After completing work on the piping system, perform a final inspection to make sure all piping connections are tightened, all gaskets are installed, and that all installations are stable and secure. Improper piping work may lead to fluid discharge, resulting in injury, burns, damage, etc.</p> <p>The unit consist of steam-using equipment and piping. Proper insulation should be installed to avoid burns or heat loss. Steam piping is hot, and even water piping may reach temperatures up to 95 °C. Insulate piping, as touching piping directly may result in burns.</p> <p>Do not climb on the component of the unit. The unit is not designed to be climbed on by people. Failure to observe this precaution may may lead to injury, failure failure or abnormal operation due to deformation of the unit.</p> <p>The unit should be operated in accordance with the proper operating steps, within the specifications of the unit, such as the maximum operating pressure (PMO) and maximum operating temperature (TMO). Refrain from sudden operation of any valves. Failure to observe these precautions is dangerous and may result in damage to the unit, malfunctions or failure of the unit, or lead to serious accidents.</p>

Precautions for Electrical Wiring

	<p>Power is supplied at 100 V AC 50/60 Hz or 200 V AC 50/60 Hz. Use of a power supply outside the above specification range may cause fires or electric shock.</p>
	<p>Make sure the power supply is OFF before carrying out work on the wiring or inspections involving disassembly. If such work is carried out with the power on, there is a danger that unit may malfunction or electric shock may occur, leading to injury or other accidents.</p>
	<p>Make sure that wiring work requiring a special license is carried out by qualified personnel. Incorrect wiring work may result in generating heat from the wiring, with the risk of injuries, burns, fire or damage due to electrical leaks, etc.</p>
	<p>Do not allow any cables or wires to come into contact with the steam piping. Steam heat will sever wiring, which may result in injury, burns, fire, damage, etc. caused by electric shock from the wiring.</p>

Precautions for Commissioning

	<p>When starting up the unit, make sure to check the display for the measured temperature and do not touch the water until the temperature becomes stable at a temperature higher than the set temperature may flow. Failure to observe these precautions is dangerous and may result in burns.</p>
	<p>The tank must be full of water before operating the heat exchanger. In particular, if water has been discharged from inside the heat exchanger for freeze prevention etc., make sure to restart the unit after supplying water to the heat exchanger. (When the cooling circulation unit (optional) is installed.) Operating the heat exchanger empty of water for a long period of time is dangerous, and may result in the pump running dry and becoming damaged.</p>
	<p>Operation should be carried out by an experienced person with such as a steam and water piping technician or an electrician, ensuring to wear a pair of heat-resistant gloves, helmet, protective glasses, etc. to prevent burns. Failure to do so may result in burns, as the piping and cover of the unit become hot during operation.</p>

Considerations for Installation Personnel

1. Work to repair malfunctions and/or damage caused by installation/operation which has been carried out in a way that differs from the contents of this manual will be charged for, even if it is within the warranty period.
2. Installation of the water supply system
TLV does not provide advice or instructions regarding piping for the entire water supply system or electrical work.
For the water supply system and electrical components to be connected to the unit, follow the instructions provided by the organization that designed and installed the system.
When the unit is connected directly to the public water supply, make sure to take measures to prevent backflow (such as installing a check valve) in accordance with the Water Supply Law (in Japan) or the applicable law where the unit is to be used.
TLV does not guarantee against damage or accidents caused by not taking measures to prevent backflow.
3. Conducting commissioning
After installing the unit, make sure to check the following items based on commissioning procedures when conducting commissioning:
 - (1) After completion of the installation work, confirm the installation work based on the "Check before the commissioning" in the "Installation Check List" on the following page.
 - (2) Make sure to observe the safety precautions when conducting the commissioning.
 - (3) After completion of the commissioning, confirm the items based on the "Check after the commissioning" in the "Installation Check List" on the following page.
4. Handling instructions for the user
The areas necessary for handling of the unit should be explained to the user according to this instruction manual.
In particular, clearly explain the "Safety Considerations" in the "Operation" chapter of this manual.
Once all the necessary instructions have been given to the user, pass the instruction manual to the user.
5. Cleaning/sterilization
The unit has been cleaned only with water from a public water supply.
If special sterilization etc. is required, please follow the instructions provided by the installation organization.
6. Measures for prevention of damage due to freezing
If there is a possibility of freezing where the unit is used, water should be drained from the unit referring to the "Damage Prevention due to Freezing" section after the commissioning. If damage to the unit occurs due to freezing, repair work will be charged for even if it occurs within the warranty period.

Installation Check List

Situation	Item	Description	✓
Before commissioning	The unit and its surroundings	Have all packed items been included?	
		Has the unit been installed securely and stably?	
		Has sufficient space required for inspection and repair been provided?	
		Has all the necessary piping been connected?	
	Electrical wiring work	Has the unit been connected to the power supply voltage (100 or 200 V AC) according to specifications? (The unit can be used at 50 Hz or 60 Hz)	
		Has the designated electrical wiring work been done?	
	Checking each part before commissioning	Have bolts and plugs been securely tightened?	
		Have the necessary valves been opened?	
		Have the air supply to the control valve positioner and the steam supply reached the required pressure?	
After commissioning	Initial blowdown	Has initial blowdown been conducted?	
	Commissioning	Has the water temperature stabilized after start-up? Does the unit repeatedly start and stop operation?	
	Leakage from each part	Have there been any leaks from any area of the unit?	
	Abnormal sounds/vibrations	Does the unit vibrate, or has there been a sound of 80 dB or more?	
	Circulating pump operation	Have the solenoid valve and circulating pump operated normally? (When the cooling circulation unit (optional) is installed.)	
	Preventative measures against freezing	Have any measures been taken for prevention of damage due to freezing if the unit is not used immediately after installation?	
	Explanation to the customer	Have instructions for safe use been given to the customer?	

Precautions for Opening and Moving the Package

1. Packed items

Make sure that the following items have been delivered and are inside the package. If not, please contact TLV immediately.

 - SteamAqua unit
 - Instruction manual for the unit (this instruction manual)
 - Instruction manual for cyclone separator trap DC3S
 - Instruction manual for control valve CV10
 - Instruction manual for electro-pneumatic positioner for control valve CV10
 - Instruction manual for PowerTrap GT14L
 - Product specification document (This may have been sent separately depending on the customer's request.)

The instruction manuals etc. are enclosed in a plastic bag attached to either the front of the control panel, or to the cushioning material.

Instruction manuals can be requested from TLV or accessed from the TLV website.
2. In the event of deformation, damage, parts breakage, missing unit components (especially measuring instruments) found when unpacking the unit, contact TLV immediately.
3. When keeping the unit in storage, make sure to store it in a dry area inside the building. Do not store the unit outdoors (e.g. covered with a waterproof sheet). The performance of the unit cannot be guaranteed in the event of rust due to rainwater intrusion and condensation.
4. Do not allow any impact to the unit when unpacking the unit. The performance of the unit cannot be guaranteed. Handle with particular care, as measuring instruments are installed on the unit.
5. When moving the packed unit, insert the forks from the left side of the unit as shown below and support the left side with cushioning material and fix with ropes, etc. if there is a step.

Do not attempt to move the unit on the tip of the forks or hoist the unit by crane in an unpacked state, as the unit may fall or be deformed.

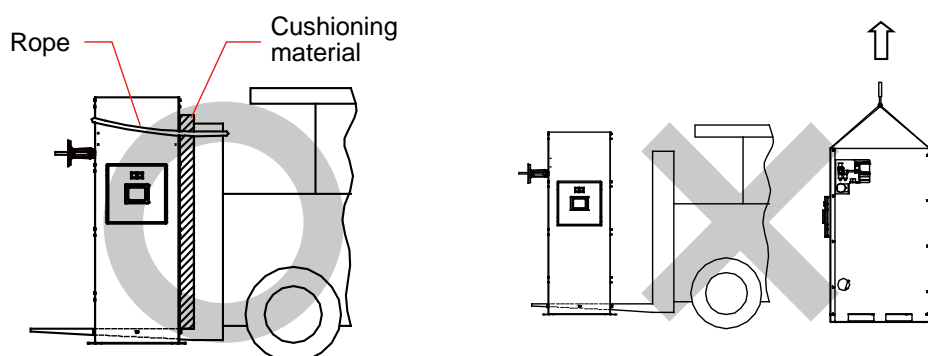

NOTE: When it is difficult to move the package into the facility by forklift:

When it is difficult to move the package into the facility by forklift, the package should be moved using an unloading belt, while the unit is still packed in a wooden box. The work must be carried out by a rigger.

The following is an example of how to move the packed unit. Ultimately, the work should be carried out in the way that the rigger judges to be safest and most appropriate.

The unit should be hoisted with an unloading belt of a length exceeding the height of the package, supporting the package from the bottom of the wooden box.

In addition, reduce the distance and time for which the unit is hoisted to a minimum and move with care. Do not keep the package hoisted while waiting, or move the package by hoisting it for a long time or distance or at high speed. When signs of damage, etc. are seen in the wooden box while a force is applied to the wooden box, stop hoisting immediately and lower the package to the ground.

In addition, do not attempt to move the package using a reassembled wooden box (a box that has been disassembled).

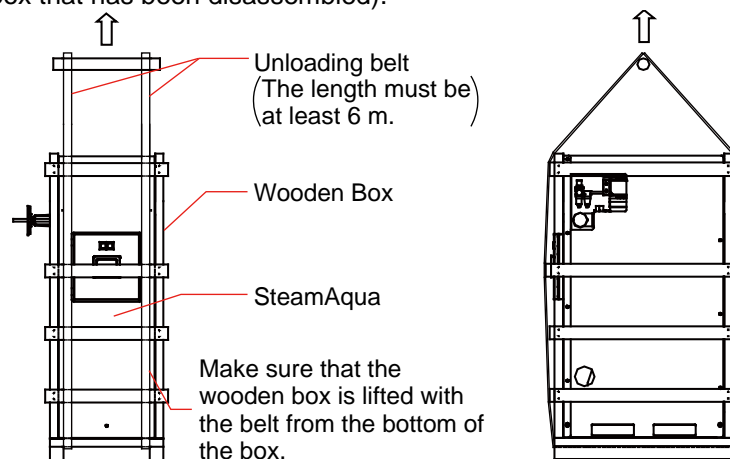

NOTE: When it is difficult to move the package into the facility while keeping the package upright, such as through a door, and the package needs to be moved in a tilted position, this movement should only be for a short time and distance.

The surface with the control panel should be facing upwards.

When tilted, ensure the unit is not tilted until it is almost horizontal.

Make sure that this side is facing upward.

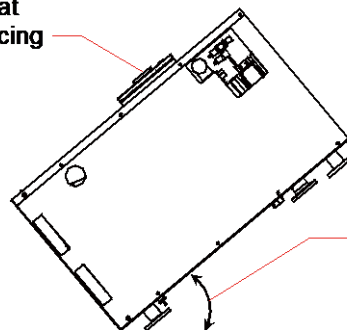

Do not over-tilt. If tilted until almost horizontal, there is a risk of damage to internal parts.

Precautions before Unit and Piping Installation

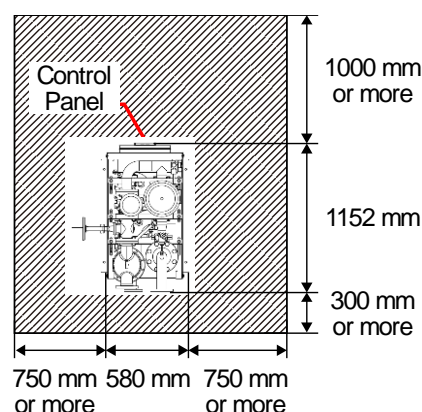

1. The unit is limited to indoor installation. Make sure to consult the user about the specific installation location.
 - (1) Where possible, discuss and confirm the unit installation method and piping/wiring work from the building's design stage.
 - (2) The unit should not be installed near staircases or evacuation exits.
 - (3) Check the drainage situation of the location where the unit to be installed, making sure that the unit will not become covered with water.
2. When installing the unit in a high place, make sure to install the unit at a location where maintenance work etc. can be carried out, and where handrails etc. are installed to prevent falling. If work cannot be performed, TLV may refuse after-sales service.
3. Install and operate the unit in a well-ventilated location with an ambient temperature up to 50 °C. When the temperature exceeds 50 °C, measures such as ventilation should be considered.
4. In areas where salt damage is likely (areas close to the ocean that receive a sea breeze), the unit should be installed in a downwind area of the building. When it is necessary to install the unit facing the coast, take measures to protect the unit from the sea breeze, such as installing a windbreak screen, etc.
5. Installation and maintenance space
 - (1) Before installing the unit, determine the installation position and then set the anchor bolts. (M12 bolts with an embedded length of 10 cm or more are recommended.) Make sure that the unit is secured with anchor bolts before installing the piping to prevent the unit from falling.
 - (2) Maintenance space
In order to inspect and repair components in the unit, set up the unit with the maintenance space in accordance with the diagram shown below to keep the sufficient distance from the surrounding walls and components. If there is insufficient maintenance space, maintenance work may be refused.
 - (3) Strength of installation floor
The weight of the unit (when empty) is approx. 450 kg. (Weight varies with optional components.)
If the floor cannot support the weight of the unit when installed, reinforcement work should be carried out before installation.
6. Precautions before installing piping:
Make sure to flush the steam piping and water supply piping before connecting the unit. Flushing the piping is different from the initial blowdown, which is carried out to discharge condensate before operation. Flushing is performed to remove the residual sealing material, metal chips, sand or scale in the piping. Therefore, it is necessary to powerfully flush the piping from as large an opening as possible.



Keep personnel and components away from the opening when flushing the piping.

Sealing material or dust entering the piping may cause problems such as deterioration of heat transfer efficiency, improper operation of the unit, valve leakage, etc.

Piping Work

 WARNING	<p>For applications such as handwashing in which hot water directly touches hands, when using the one-pass method, make sure to install a thermostatic mixing valve on the outlet. Failure to observe this precaution may result in burns, as water at a temperature higher than than the set temperature may flow due to load fluctuations.</p>
 CAUTION	<p>To use the unit safely and properly, read this instruction manual carefully to carry out the specified work. Installation, moving and incidental work of the unit requires professional qualifications and skills. The work should be carried out by a qualified personnel. Once installation is complete, make sure that the work is carried out based on the instruction manual. Work carried out improperly may lead to accidents or unit malfunction.</p> <p>Do not use well water or water from a hot spring. Depending on the water quality, foreign matter may adhere to, or corrosion may occur in, the unit piping, resulting in water leaks. In this case, there will be a charge for repair work even during the warranty period.</p> <p>Do not use excessive force when connecting threaded pipes to the unit. Over-tightening may cause breakage leading to the unit damage, fluid discharge during operation, injury, burns, etc.</p> <p>Make sure that work (such as transportation, installation, welding or wiring) requiring a special license is carried out by qualified personnel. Improper work may lead to falls, heat generation, injuries due to electrical leakage, fire or damage.</p> <p>After completing work on the piping system, perform a final inspection to make sure all piping connections are tightened, all gaskets are installed, and that all installations are stable and secure. Improper piping work may lead to fluid discharge, resulting in injury, burns, damage, etc.</p> <p>The unit consist of steam-using equipment and piping. Proper insulation should be installed to avoid burns or heat loss. Steam piping is hot, and even water piping may reach temperatures up to 95 °C. Insulate piping, as touching piping directly may result in burns.</p> <p>Do not climb on the component of the unit. The unit is not designed to be climbed on by people. Failure to observe this precaution may may lead to injury, failure or abnormal operation due to deformation of the unit.</p> <p>The unit should be operated in accordance with the proper operating steps, within the specifications of the unit, such as the maximum operating pressure (PMO) and maximum operating temperature (TMO). Refrain from sudden operation of any valves. Failure to observe these precautions is dangerous and may result in damage to the unit, malfunctions or failure of the unit, or lead to serious accidents.</p> <p>Once the product has been installed and connected to the system piping, supply steam to heat the product piping. Only after the surface temperature of the product piping has returned to room temperature, retighten all the piping connections. Piping connections may loosen due to vibration during transportation or installation, or steam heat. This can lead to fluid discharge, which may cause burns or other injury.</p>

1. For piping:
 - (1) The pipe diameter should not be smaller than the diameter of the unit connections.
 - (2) For steam piping, make sure the piping is connected with a downward slope on the downstream side.
 - (3) The piping should be kept simple, with as few joints as possible in order to avoid pressure loss.
 - (4) Make sure that the piping is arranged so that air does not accumulate inside the piping. Take measures for the location where air may accumulate, such as installing an air vent valve, etc. so that air does not accumulate.
2. Precautions for installing piping:

Precautions for installing piping at locations A to D (as shown below) are on the following page.

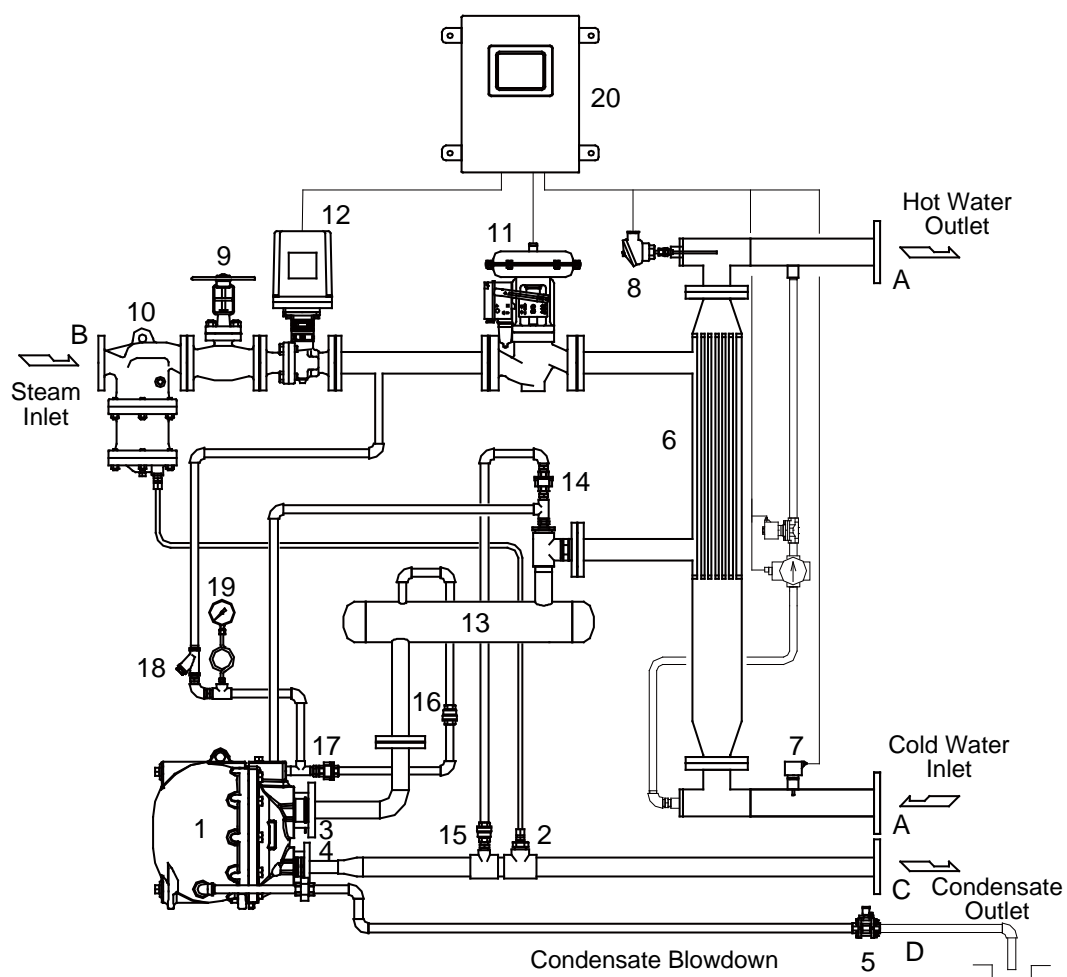

A. Cold water inlet, hot water outlet

The cold water inlet and hot water outlet of the unit are connected to the inlet/outlet of the heat exchanger. Make sure to follow the installation procedures regardless of the instructions provided. These are the minimum precautions to prevent this unit from being damaged or malfunctioning.

- (1) Make sure to install valves (preferably full bore gate valves) near the cold water inlet and hot water outlet, giving consideration to maintenance of the unit.
- (2) Install a safety valve (relief valve) (not included with the unit) on the hot water outlet piping (to prevent damage to the unit due to the pressure rise which may occur under abnormal conditions). (The pressure for the safety valve (relief valve) should be set at 0.9 MPaG or less. Also, if there is equipment with a lower pressure tolerance than the unit, make sure to select the appropriate valve for that equipment.)
- (3) When the water temperature is set to a high temperature, do not use PVC or lead piping intended for water supply as there is a possibility that the inlet piping may become hot even if the water temperature on the inlet side is low.
- (4) Install hot water outlet piping with a pipe rise. (Make sure that the tip of the unit's temperature sensor is fully immersed in water.)
- (5) There is no valve for drainage in the unit. Make sure to install a valve for drainage to ensure ease of maintenance.
- (6) A flow switch (for sensing the flow rate) is installed at the cold water inlet. To prevent the switch from operating erroneously, straight piping 500 mm or longer should be installed before the cold water inlet.

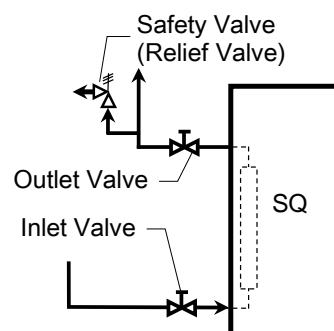

The procedures below should also be followed according to the type of hot water supply piping used by the system.

A-(1): For single-pass system hot water piping

In single-pass systems, the cold water supplied to the unit is heated and supplied to the point of use, and is not returned to the unit by recirculation etc.

- a) After stopping hot water use, heat expansion occurs due to water being heated by the residual heat in the heat exchanger. Install a check valve on the cold water inlet piping to prevent hot water backflow due to heat expansion.

After closing the valve or tap at the point of use, or stopping hot water use, the pressure inside the piping will increase if heat expansion occurs and there is no pressure relief port. If there is no way to relieve the pressure, this may lead to damage to piping or the unit, therefore a pressure relief device such as a safety valve should be installed between the unit and the point of use.

The rapid opening and closing of ball valves can cause water hammer to occur, potentially damaging the unit. Take measures to prevent rapid valve operation.

A-(2): For recirculating system hot water piping

In recirculating systems, the cold water supplied to the unit is heated, then some is supplied to the point of use, and some is returned to the unit via the recirculation piping.

- a) Install air vent(s), safety valves for pressure relief and expansion tanks (if required) as appropriate on the hot water piping
- b) Install the mixing section (for hot water returned from the recirculation piping and cold supply water) at least 1 m away from the cold water inlet of the unit. This is to prevent erroneous operation of the flow switch.

B. Steam inlet piping

- (1) Steam pipes should always be taken from the top of the steam main.
- (2) Install a blow valve before the unit in order to be able to flush the piping before the commissioning or after the unit has been shut down for a long period of time.
- (3) Install a Y-type strainer on the steam inlet piping to allow entrained foreign matter to be removed during operation.
- (4) Install a steam trap in order to prevent condensate accumulating in steam piping even if the unit is not in service or stopped.
- (5) If the steam supply pressure of the unit is 0.4 MPaG or more, the pressure should be reduced with a pressure reducing valve, etc. The pressure reducing valve should be installed as far as possible from the unit (5 m or more is recommended) to obtain a stable steam supply pressure. (Refer to the instruction manual for the pressure reducing valve to be used.)

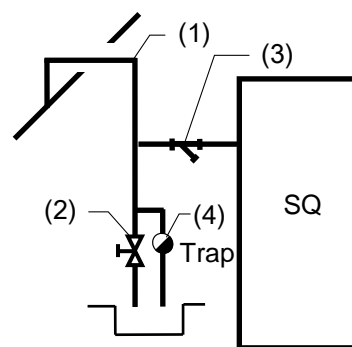

If a safety valve (relief valve) is installed between the pressure reducing valve and the unit, the safety valve (relief valve) may operate due to shut-off pressure rise when there is low demand on the unit, etc. Install a shut-off valve before the pressure reducing valve, keep the valve closed when not using the unit, and take measures so that the safety valve (relief valve) does not operate due to shut-off pressure rise.

NOTE: If a pressure of 0.43 MPaG or more is applied to the unit, it falls outside of pressure vessel regulation range, rendering the unit unusable in legal terms. When the primary pressure of the pressure reducing valve exceeds 0.43 MPaG, make sure to install a safety valve (relief valve) between the pressure reducing valve and the unit.

C. Condensate outlet piping

Make sure to pipe the discharged condensate to a safe area such as a pit.

- (1) The temperature of steam condensate discharged from the unit exceeds 100 °C. Do not use PVC or lead piping intended for water supply.
- (2) The sound of steam flashing (a small pinging sound) may occur from the opening of the condensate outlet piping. To reduce the sound, extend the condensate outlet piping by 3 m or more.
- (3) When the PowerTrap (No. 1) pumps the condensate, it is discharged vigorously from the condensate outlet piping. When the end of the piping is open to the atmosphere, take safety measures such as installing a cover so that there is no burn caused by condensate splashing, and no influence on components.
- (4) When the condensate recovery piping installed after the condensate outlet piping has a pipe rise, make sure to install a valve after the unit. This enables easier maintenance work for the internal components in the unit such as the PowerTrap and prevents backflow from the condensate outlet piping.
- (5) The diameter of the condensate piping installed after the unit must be designed and selected to accommodate two phase flow. (The condensate piping diameter must be larger than the diameter of the unit outlet.)



Condensate
Outlet Pipe

D. Condensate blow piping

Make sure to pipe the discharged condensate to a safe area such as a pit.

Condensate in the PowerTrap must be discharged to prevent freezing or corrosion when the unit is shut down for a long period of time.

The piping should not have any pipe rise after this valve as the condensate needs to be discharged naturally (by gravity).



Installing Several SteamAqua Units in Parallel

When installing several units in parallel, make sure that the water flow to the units is evenly distributed.

If the water flow is uneven, the unit with the higher flow rate becomes overloaded, and the required temperature rise may be obtainable.

The piping arrangement to evenly distribute water to each unit is described below:

- (1) The size of each branch pipe from the cold water inlet piping to the unit connection should be the same.
The size of each branch pipe from the unit connection to the hot water outlet should be same.

- (2) Install a globe valve (not included with the unit) on each cold water inlet branch pipe, so that the flow rate to each unit can be adjusted.
Use full bore globe valves that have the same diameter as the cold water branch piping.

The opening of the globe valves should be adjusted so the measured temperature of the water side of each unit becomes the set temperature. Furthermore, if each unit indicates a similar value for the control valve opening, more stable heating is possible. (Control valve opening values can be confirmed on the main screen of the control panel.)

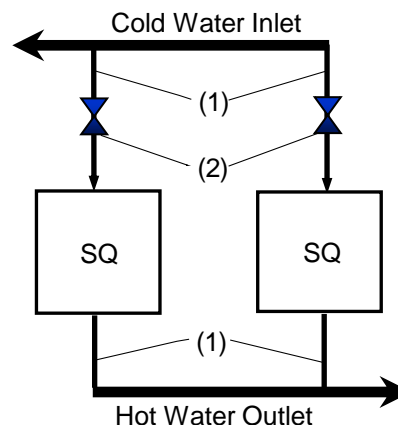

Electrical Wiring

 CAUTION	<p>Power should be supplied at the voltage and frequency applicable for each SQ version. (Standard models: 100 V AC at 50 Hz or 60 Hz, Oceania models: 240 V AC at 50 Hz). Use of a power supply outside the above specification range may cause fires or electric shock.</p>
	<p>Make sure the power supply is OFF before carrying out work on the wiring or inspections involving disassembly. If such work is carried out with the power on, there is a danger that unit may malfunction or electric shock may occur, leading to injury or other accidents.</p>
	<p>Make sure that wiring work requiring a special license is carried out by qualified personnel. Incorrect wiring work may result in generating heat from the wiring, with the risk of injuries, burns, fire or damage due to electrical leaks, etc.</p>
	<p>Do not allow any cables or wires to come into contact with the steam piping. Steam heat will sever wiring, which may result in injury, burns, fire, damage, etc. caused by electric shock from the wiring.</p>

1. Make sure to carry out electrical connections in accordance with JIS standards etc. (Control panel arrangement may differ from the picture below.)

- (1) Voltage/frequency: 100 V AC 50/60 Hz or 200 V AC 50/60 Hz

- (2) Maximum power consumption:
Standard: 60 W

When the cooling circulation unit (optional) is in operation: 170 W (during operation)

- (3) Install an earth leakage circuit breaker that can automatically cut off the circuit on the power supply side.

- (4) When the breaker cannot be grounded in the control panel, make sure to perform D class grounding (with ground resistance of 500 Ω or less).

- (5) Do not ground to water piping, steam piping, telephone lines or lightning rods.



2. Connecting the power supply cable

- (1) Open the cover of the control panel and pass the cable through the control board from the cable connector on the front left.



- (2) Connect the power supply cable to the L, N and E terminal blocks on the far left. (200 V control panel is shown in the photo on the right.)

(When voltage/frequency is 200 V AC: R, T, E
When voltage/frequency is 200 V and the cooling circulation unit (optional) control panel is installed: R, S, T, E)

When wiring the power cable to the terminal block, use rod terminals or ferrule terminals.

L, N (R, S, T): Power source

E: Ground



- (3) When wiring the power cable or other cabling from the unit elsewhere, make sure that the unit cover can still be removed. (Do not fix electrical conduits, etc. to the cover.) If the unit cover cannot be removed, unit commissioning or maintenance may be refused.

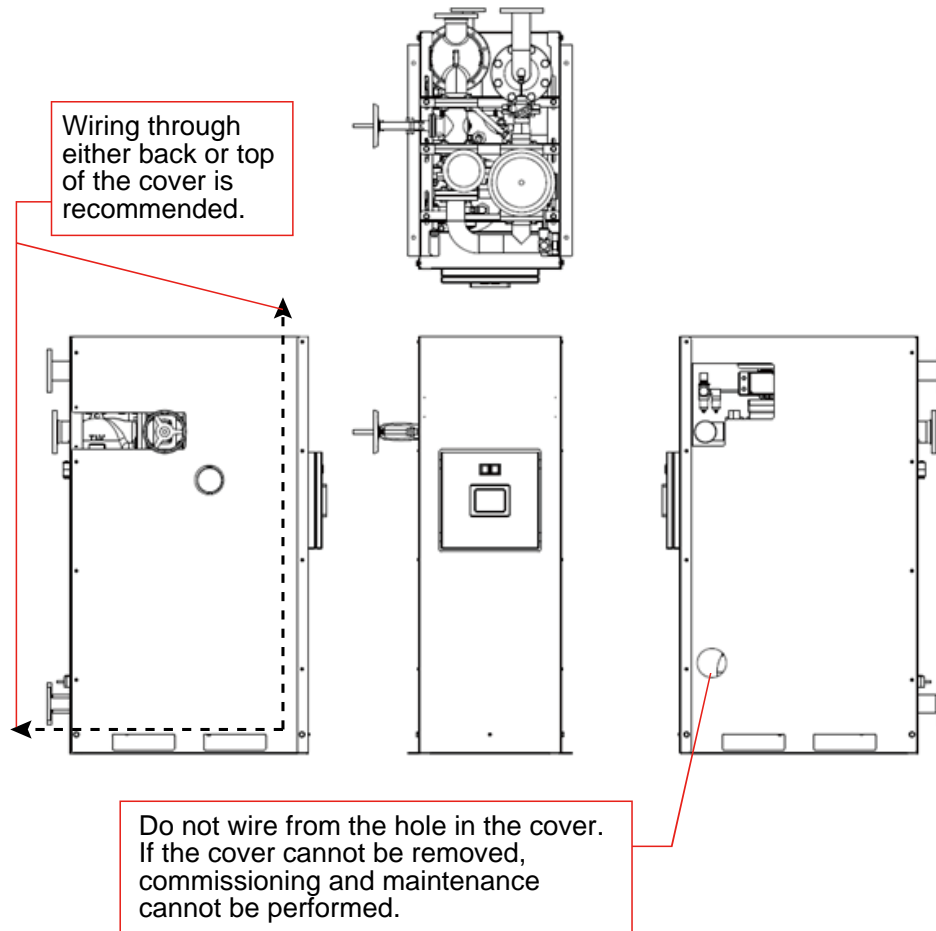

3. External input/output

The unit is capable of receiving the following inputs:

(1) Operation input (voltage free contact, pulse)

Operation of the unit can be started/stopped. For signals, use voltage free contacts that can be operated for 1 to 3 seconds.

In addition, make sure that the "Operation Start" and "Operation Stop" contacts are not closed simultaneously, as doing so can cause the unit to malfunction.

Terminal block numbers:

Operation Start: +V, 13

Operation Stop: -V, 14

(2) Target value input (analog signal)

The target temperature value can be set remotely by switching on the Set Temperature Remote Input button.

The analog signal input should be between 4 and 20 mA.

When setting the target value via analog signal, the set temperature range is from 0 °C to 100 °C.

Therefore, the output range should be: 4 mA → 0 °C, 20 mA → 100 °C.

Terminal block numbers: 07, 08, SE*

* Should be used as ground for shielded cables

NOTE: Discrepancies may occur between the input current value and the set temperature, depending on the situation (e.g. when the signal is 12 mA, the temperature is 50.3 °C instead of 50 °C).

Be sure to carry out thorough adjustments before using.

Furthermore, the following output can be obtained.

(3) Operation output (voltage free contact)

The signal can be obtained as a voltage free contact external signal during operation.

Terminal block numbers: Operation

Output: 23, 24

(4) Alarm output (voltage free contact)

Signals for high temperature alarm, low temperature alarm and system alarms can be obtained as an external signal of the voltage free contacts.

NOTE: One signal for all outputs.

Terminal block numbers: Temperature

Alarm Output: 25, 26

(5) Hot water outlet temperature (analog signal)

The outlet temperature of water can be obtained from the control panel as a 4

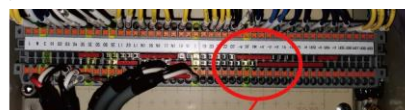

Target value input

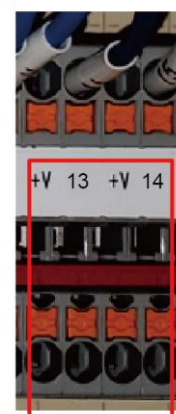

Operation input

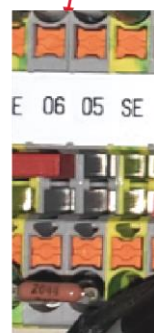

Hot water outlet temp.



Operation Alarm output

mA to 20 mA external signal.

When obtaining the hot water outlet temperature via analog signal, the output range should be: 4 mA → 0 °C, 20 mA → 100 °C.

- (6) Terminal block numbers: Output Temperature Measured Value: 06, 05, SE
 (7) Emergency stop input (voltage free contact):

When there is a requirement for components other than the unit, such as master control panels or temperature switches, to force the unit to do an emergency stop from the control circuit, these terminals can be used to conduct the emergency stop.

(Emergency stop refers to a loop that forcefully stops the power supply to the sequencer which contains the unit's control program.)

The unit cannot restart while the emergency stop input is consistently supplied. Furthermore, since the loop forces the power supply to the sequencer and touch panel to be shut down, the operation history will not remain in the alarm log.

Terminal block numbers: L1 (R1), (28)



4. Option: Wiring of the control panel for the circulating pump

The unit has an optional control panel for the circulating pump. In order to link up with operation of the circulating pump, the circulating pump should be connected to this control panel.

- (1) Remove the side cover from side of the unit on which the control panel for the circulating pump is installed.

- (2) Remove the control panel cover.

Loosen each of the corner screws with a Phillips screwdriver to remove the cover. When reattaching the cover after the wiring work is complete, make sure that each screw on every corner has been firmly fastened so there are no gaps between the cover and body.

Any gaps between the cover and body will limit the waterproof protection for the control panel, and consequently water leakage from piping etc. may cause an accident such as an electric leakage.

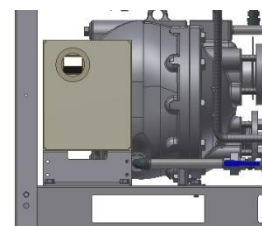

- (3) Connect the power cable to the E, L2 and N3 terminal blocks.

Terminal block numbers:

Pump power source:

L2, N3 (for 100 V AC)

U, V, W (for 200 V AC)

Ground: E

(Pump power is limited to single phase 100 V AC, 0.4 kW or less.)

(The ground is shared with the ground of 100 V AC power supply for the main control panel.)

- (4) When obtaining the operation output to display the operation status, use the output terminal on the control panel for the circulating pump.

The operation output of the unit's control panel (as mentioned on the previous page) is used in linking with the control panel for the circulating pump, therefore the terminal block of the control panel for the circulating pump is used.

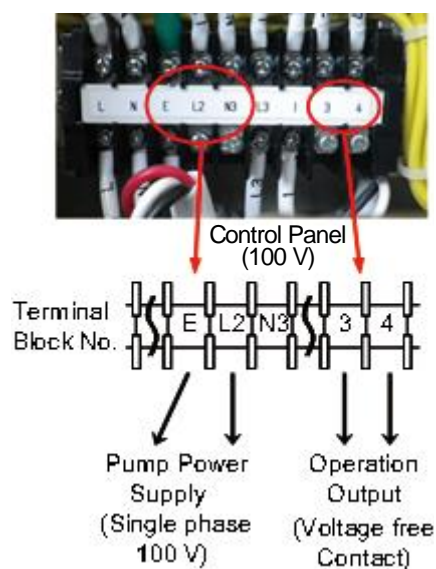

Commissioning Procedure

 CAUTION	<p>When starting up the unit, make sure to check the display for the measured temperature and do not touch the water until the temperature becomes stable at a temperature higher than the set temperature may flow. Failure to observe these precautions is dangerous and may result in burns.</p>
	<p>The tank must be full of water before operating the heat exchanger. In particular, if water has been discharged from inside the heat exchanger for freeze prevention etc., make sure to restart the unit after supplying water to the heat exchanger. Operating the heat exchanger empty of water for a long period of time is dangerous, and may result in the pump running dry and becoming damaged.</p>
	<p>Operation should be carried out by an experienced person with such as a steam and water piping technician or an electrician, ensuring to wear a pair of heat-resistant gloves, helmet, protective glasses, etc. to prevent burns. Failure to do so may result in burns, as the piping and cover of the unit become hot during operation.</p>
	<p>Install properly and DO NOT use this unit outside the recommended operating pressure, temperature and other specification ranges. Improper use may result in such hazards as damage to the unit or malfunctions which may lead to below the conditions quoted.</p>

1. Safety considerations for the commissioning:
Commissioning should be carried out by the person who installed the unit or by the water system manager.
Make sure no-one touches the water (by washing hands, etc.) at the location for water usage as this is a test operation as part of commissioning.

2. Checking each area before commissioning:

- (1) Check the tightness of bolts and plugs.

Make sure that all joints for flanges and plugs are tightened.

- (2) Check if valves are open or closed.

- Steam inlet valve (No. 9):

Closed

- Control valve (No. 11):

Closed

- Condensate Blowdown

Valve (No. 5): Closed

Other valves on the water supply system (not included with the unit) should also be closed.

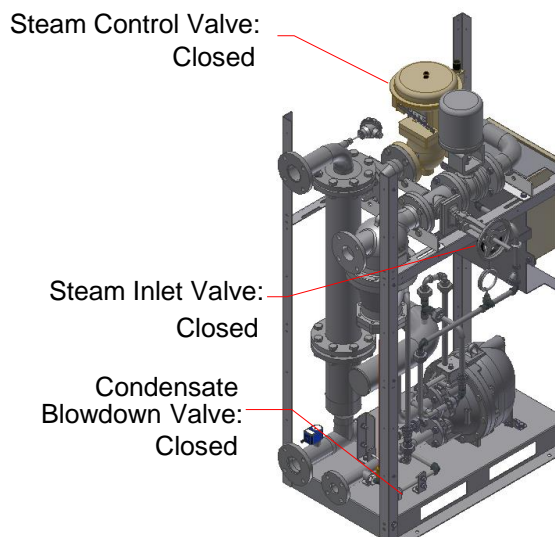

(3) Initial blowdown:

Before commissioning, open the valve installed immediately before the unit ((1) in the figure on the right) and blow any scale out from the piping. This step can be skipped if scale has already been blown off before the pipe is connected.

If blowdown has not been adequately carried out, TLV cannot guarantee against damage or performance loss of valves and the unit as a result of scale.

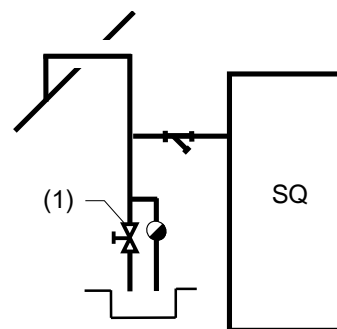

- (4) Make sure that the power supply indicator on the control panel is lit and the power is supplied to the control panel. (Control panel arrangement may differ from the picture on the right.)



When the power supply indicator is not lit, power may not be supplied to the control panel. Contact an electrician. Together with the electrical system manager, investigate the cause, by checking the wiring, etc.

- (5) Check the operation status on the touch panel, making sure that the operation status is "STOP".

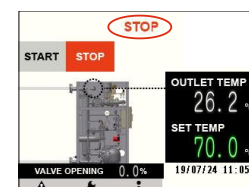

- (6) Make sure that steam is supplied up until the steam inlet valve (No. 9) and the steam pressure does not exceed 0.4 MPaG, which is the maximum operating pressure for the unit.

- (7) Make sure that the air pressure specified below is supplied to the positioner of the control valve (No. 11). When the air pressure has not reached the specified value, set the pressure to the specified value by turning the regulator handle. (Set pressure: 0.38 MPaG)

When adjusting the air pressure, lift up the regulator handle until the orange sticker is visible, then turn the handle.



3. Starting commissioning

(1) Valve operation:

Open the steam inlet valve (No. 9) as slowly as possible.

Make sure that condensate is discharged from the condensate separator (No. 10) and the value indicated on the pressure gauge

(No. 19) is stable at the predetermined value (recommended value: 0.2 to 0.4 MPaG.)

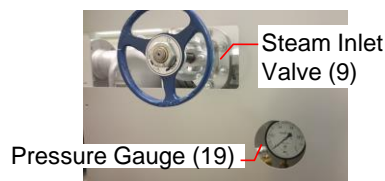

(2) Stand-by operation (STARTING UP...)

a) Touch the START button on the display.

b) Even if the START button is touched, steam will not flow unless water is flowing.

If water is already flowing at a temperature above the set temperature, (3) is the next step.

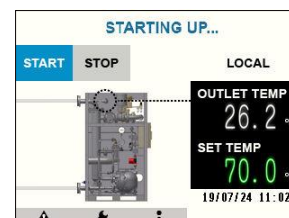

(3) Valve operation for the water supply system

Open the valve (not included with the unit) on the water supply system.

If the valve is in a remote location, one person should operate the valve and one person should remain by the unit for observation.

(4) Starting operation

When the water reaches or exceeds the set flow rate¹⁾, the flow sensor (No. 7) turns ON to start the operation after the standby time of 5 seconds²⁾ ³⁾. (The LED lamp of the flow amplifier in the control panel lights up in yellow or green.)

The motorized valve (No. 12) opens and the control valve (No. 11) adjusts the steam flow rate.

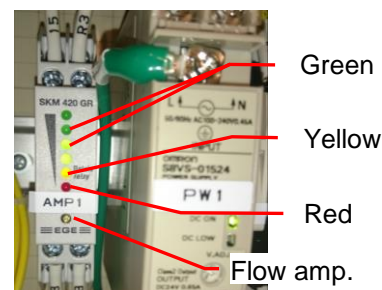

The time required for the water to reach the set temperature is approximately 1 to 4 minutes, depending on the operating conditions.

¹⁾ The set flow rate of water is the minimum controllable flow rate for the unit under operating conditions. (Factory setting: see 'product specification document'.)

²⁾ Alarm delay time is the time required to reach stable flow after water begins to flow, or the time required for the cooling circulation unit to operate to prevent overheating when the water flow stops. (Factory setting: 5 seconds).

³⁾ If the water flow rate does not stabilize within 5 seconds and the unit repeatedly starts and stops operation, the alarm delay time must be changed. Consult TLV on how to change settings.

(5) Water temperature:

The difference between the target temperature and the water temperature is normally ± 1 °C, depending on the operating conditions.

When the temperature difference is 3 °C or more, or when the water temperature fluctuates, it is likely that the water flow rate is also fluctuating greatly or is below/around the controllable flow rate. In such cases, contact the facility manager.

(6) Checking the water flow rate:

The unit does not include a water flow rate display function. However, a basic indication of the flow rate can be obtained by checking the flow amplifier LEDs on the control panel to verify whether water is flowing at the set flow rate.

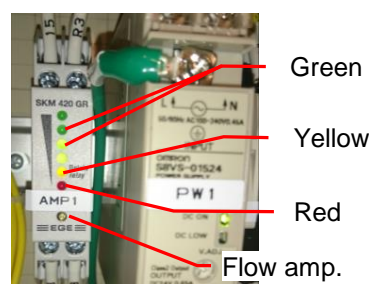

Red: Insufficient water amount (operation impossible)

Yellow: Water amount is near the set value

Green (one or more lamp is lit): Water amount is above the set value

(7) Operational check of the flow sensor:

It is possible to confirm whether the flow sensor is operating (switching) normally by checking the LED lamp of the flow amplifier is lit and flow rate is displayed in the touch panel when water is supplied to the unit at a flow rate that exceeds the set flow rate of the flow sensor.

The flow rate of the flow sensor set at the factory will be a stable and controllable water amount value as stated in the 'product specification document'. However, when the commissioning is conducted by TLV, the flow rate may be adjusted according to the operation conditions of the user.

(8) Adjusting the set temperature

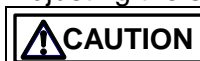

Do not change the temperature settings without contacting the user when washing hands, using a shower or cleaning.
Failure to do so may result in burns to the user.

Touch the "Set Temperature Adjustment" button on the touch panel, and using the keyboard panel, input the desired temperature.

Adjustment of the target temperature should be carried out when the water flow rate is stable or when operation is stopped.

Do not drastically reduce the set temperature from a high temperature to a lower temperature when using water continuously while the unit is in operation.

Even after the upper limit alarm delay time (factory setting: 10 seconds) has expired, any temperature difference that exceeds the upper limit set temperature alarm value (factory setting: 10 °C) will cause the high temperature alarm to be triggered, causing the unit to immediately stop operation.

When the temperature is set outside the capability range shown below, the temperature may not reach the target temperature or the temperature may fluctuate. In such cases, contact the facility manager.

(The thermal capability range of the SQ10 is 120 to 1200 kW. Even within this range, there are cases where water does not reach the target temperature depending on the temperature and flow rate conditions.)

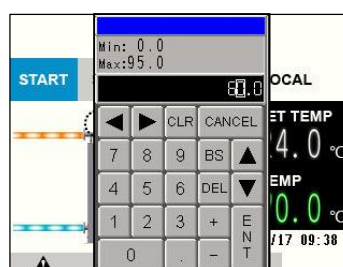

4. Maintaining operation

(1) Checking for leakage:

When the unit starts to supply the required water temperature, maintain this state for 5 minutes or more.

During this time, make sure that no leakage, abnormal sounds or vibrations are observed in each area of the steam piping or water systems.

(2) Operating the PowerTrap:

When the PowerTrap operates, a "clunk" may be heard. This is not an abnormal sound, because it is the sound made by the PowerTrap when discharging and pumping the condensate.

When this operation sound cannot be heard, it is not abnormal since the PowerTrap is operating as a normal steam trap. If the PowerTrap fails, condensate will not be discharged properly, resulting in a gradual decrease of the water temperature.

- (3) The condensate outlet receives high temperature condensate from the cyclone separator and low temperature condensate from the PowerTrap inside the unit. Therefore, when low temperature condensate mixes with flash steam (created by high temperature condensate re-evaporating), a small amount of water hammer occurs. The silencer bush (No. 2) is installed to reduce the water hammer.



However, the sound of the water hammer cannot be eliminated completely. It is not abnormal to hear a small pinging sound may be heard from around the silencer bush.

(4) When the set temperature is adjusted:

When the set temperature of the unit is adjusted within its capacity, maintain that temperature for about 10 minutes until the water temperature becomes stable.

- (5) Checking the circulating pump (Option: No. 6) and solenoid valve (Option: No. 7) (when the cooling circulation unit (optional) is installed):
Check to make sure the circulating pump is operating properly by stopping the inflow of water during operation.



The circulating pump and solenoid valve can be confirmed to be operating correctly if vibration due to water flow can be felt when touching the pump or valve piping.

When touching the inner piping of the pump, take care not to avoid burns, as the piping may be hot.

Even if the water supply valve on the water system side (not included with the unit) is closed, an operational check can be performed, as the circulating pump still operates on the heat exchanger (No. 6).

5. Shutdown

- (1) Close the steam inlet valve (No. 9) slowly.

When the STOP button is touched on the touch panel without closing the steam inlet valve, the following conditions may be caused by the steam flow suddenly stopping:

- The steam source pressure temporarily rises and the safety valve (relief valve) (not included with the unit) installed on the pipe before the steam inlet valve opens.
- Supply pressure to other steam-using equipment becomes unstable.

If there are no such conditions likely to occur, touch the STOP button to stop operation. (Continue to Step 3.)

- (2) Make sure that the indicated value of the pressure gauge (No. 19) becomes "0" and steam residual pressure is not applied to the unit.

- (3) Touch the STOP button.

The motorized valve (No. 12) and the control valve (No. 11) close, the solenoid valve (No. 23) of the cooling circulation unit opens and the circulating pump (No. 22) operates. At this time, "STOPPING..." is displayed on the touch panel.

(The time required for operation to stop is approx. 30 seconds.)

- (4) When the process to stop operation is complete, the unit's internal systems have fully stopped.

Make sure that "STOP" is displayed on the touch panel and all components in the unit (except touch panel and sensors) have stopped.

- (5) Close the valve (not included with the unit) on the water supply system to stop supplying water to the unit.

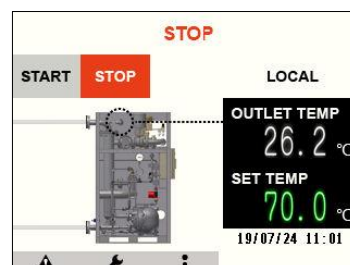
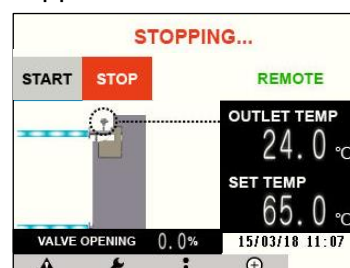
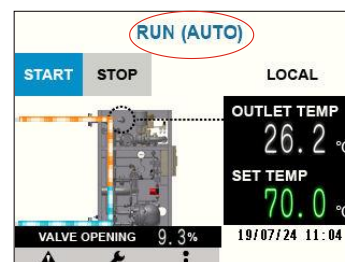

6. Prevention of damage due to freezing



When discharging water from the unit, make sure to wait until the unit has cooled down.

If carrying out work after hot water use, there is a risk of burns, as the unit and the water inside the unit are hot.

Make sure measures are taken to prevent freezing of the unit's steam piping system in cold climates. If a component is damaged due to freezing, repair will be charged even within the warranty period.

Water in the water supply system cannot be discharged with the unit. To prevent freezing of water supply system, contact the administrator of the water system.

(1) Draining procedure

Make sure that the steam inlet valve (No. 9) is closed and the unit has completely stopped and cooled down.

- (2) Open the condensate blow valve (No. 5) of the PowerTrap unit to discharge steam condensate. Make sure to close the valve after confirming the steam condensate has been drained completely. Mistakenly leaving the valve open is dangerous, as steam or condensate may be discharged during operation start-up.



TLV EXPRESS LIMITED WARRANTY

Subject to the limitations set forth below, TLV CO., LTD., a Japanese corporation (“**TLV**”), warrants that products which are sold by it, TLV International Inc. (“**TII**”) or one of its group companies excluding TLV Corporation (a corporation of the United States of America), (hereinafter the “**Products**”) are designed and manufactured by TLV, conform to the specifications published by TLV for the corresponding part numbers (the “**Specifications**”) and are free from defective workmanship and materials. The party from whom the Products were purchased shall be known hereinafter as the “**Seller**”. With regard to products or components manufactured by unrelated third parties (the “**Components**”), TLV provides no warranty other than the warranty from the third party manufacturer(s), if any.

Exceptions to Warranty

This warranty does not cover defects or failures caused by:

1. improper shipping, installation, use, handling, etc., by persons other than TLV, TII or TLV group company personnel, or service representatives authorized by TLV; or
2. dirt, scale or rust, etc.; or
3. improper disassembly and reassembly, or inadequate inspection and maintenance by persons other than TLV or TLV group company personnel, or service representatives authorized by TLV; or
4. disasters or forces of nature or Acts of God; or
5. abuse, abnormal use, accidents or any other cause beyond the control of TLV, TII or TLV group companies; or
6. improper storage, maintenance or repair; or
7. operation of the Products not in accordance with instructions issued with the Products or with accepted industry practices; or
8. use for a purpose or in a manner for which the Products were not intended; or
9. use of the Products in a manner inconsistent with the Specifications; or
10. use of the Products with Hazardous Fluids (fluids other than steam, air, water, nitrogen, carbon dioxide and inert gases (helium, neon, argon, krypton, xenon and radon)); or
11. failure to follow the instructions contained in the TLV Instruction Manual for the Product.

Duration of Warranty

This warranty is effective for a period of one (1) year after delivery of Products to the first end user. Notwithstanding the foregoing, asserting a claim under this warranty must be brought within three (3) years after the date of delivery to the initial buyer if not sold initially to the first end user.

ANY IMPLIED WARRANTIES NOT NEGATED HEREBY WHICH MAY ARISE BY OPERATION OF LAW, INCLUDING THE IMPLIED WARRANTIES OF MERCHANTABILITY AND FITNESS FOR A PARTICULAR PURPOSE AND ANY EXPRESS WARRANTIES NOT NEGATED HEREBY, ARE GIVEN SOLELY TO THE INITIAL BUYER AND ARE LIMITED IN DURATION TO ONE (1) YEAR FROM THE DATE OF SHIPMENT BY THE SELLER.

Exclusive Remedy

THE EXCLUSIVE REMEDY UNDER THIS WARRANTY, UNDER ANY EXPRESS WARRANTY OR UNDER ANY IMPLIED WARRANTIES NOT NEGATED HEREBY (INCLUDING THE IMPLIED WARRANTIES OF MERCHANTABILITY AND FITNESS FOR A PARTICULAR PURPOSE), IS **REPLACEMENT**; PROVIDED: (a) THE CLAIMED DEFECT IS REPORTED TO THE SELLER IN WRITING WITHIN THE WARRANTY PERIOD, INCLUDING A DETAILED

WRITTEN DESCRIPTION OF THE CLAIMED DEFECT AND HOW AND WHEN THE CLAIMED DEFECTIVE PRODUCT WAS USED; AND (b) THE CLAIMED DEFECTIVE PRODUCT AND A COPY OF THE PURCHASE INVOICE IS RETURNED TO THE SELLER, FREIGHT AND TRANSPORTATION COSTS PREPAID, UNDER A RETURN MATERIAL AUTHORIZATION AND TRACKING NUMBER ISSUED BY THE SELLER. ALL LABOR COSTS, SHIPPING COSTS, AND TRANSPORTATION COSTS ASSOCIATED WITH THE RETURN OR REPLACEMENT OF THE CLAIMED DEFECTIVE PRODUCT ARE SOLELY THE RESPONSIBILITY OF BUYER OR THE FIRST END USER. THE SELLER RESERVES THE RIGHT TO INSPECT ON THE FIRST END USER'S SITE ANY PRODUCTS CLAIMED TO BE DEFECTIVE BEFORE ISSUING A RETURN MATERIAL AUTHORIZATION. SHOULD SUCH INSPECTION REVEAL, IN THE SELLER'S REASONABLE DISCRETION, THAT THE CLAIMED DEFECT IS NOT COVERED BY THIS WARRANTY, THE PARTY ASSERTING THIS WARRANTY SHALL PAY THE SELLER FOR THE TIME AND EXPENSES RELATED TO SUCH ON-SITE INSPECTION.

Exclusion of Consequential and Incidental Damages

IT IS SPECIFICALLY ACKNOWLEDGED THAT THIS WARRANTY, ANY OTHER EXPRESS WARRANTY NOT NEGATED HEREBY, AND ANY IMPLIED WARRANTY NOT NEGATED HEREBY, INCLUDING THE IMPLIED WARRANTIES OF MERCHANTABILITY AND FITNESS FOR A PARTICULAR PURPOSE, DO NOT COVER, AND NEITHER TLV, TII NOR ITS TLV GROUP COMPANIES WILL IN ANY EVENT BE LIABLE FOR, INCIDENTAL OR CONSEQUENTIAL DAMAGES, INCLUDING, BUT NOT LIMITED TO LOST PROFITS, THE COST OF DISASSEMBLY AND SHIPMENT OF THE DEFECTIVE PRODUCT, INJURY TO OTHER PROPERTY, DAMAGE TO BUYER'S OR THE FIRST END USER'S PRODUCT, DAMAGE TO BUYER'S OR THE FIRST END USER'S PROCESSES, LOSS OF USE, OR OTHER COMMERCIAL LOSSES. WHERE, DUE TO OPERATION OF LAW, CONSEQUENTIAL AND INCIDENTAL DAMAGES UNDER THIS WARRANTY, UNDER ANY OTHER EXPRESS WARRANTY NOT NEGATED HEREBY OR UNDER ANY IMPLIED WARRANTY NOT NEGATED HEREBY (INCLUDING THE IMPLIED WARRANTIES OF MERCHANTABILITY AND FITNESS FOR A PARTICULAR PURPOSE) CANNOT BE EXCLUDED, SUCH DAMAGES ARE EXPRESSLY LIMITED IN AMOUNT TO THE PURCHASE PRICE OF THE DEFECTIVE PRODUCT. THIS EXCLUSION OF CONSEQUENTIAL AND INCIDENTAL DAMAGES, AND THE PROVISION OF THIS WARRANTY LIMITING REMEDIES HEREUNDER TO REPLACEMENT, ARE INDEPENDENT PROVISIONS, AND ANY DETERMINATION THAT THE LIMITATION OF REMEDIES FAILS OF ITS ESSENTIAL PURPOSE OR ANY OTHER DETERMINATION THAT EITHER OF THE ABOVE REMEDIES IS UNENFORCEABLE, SHALL NOT BE CONSTRUED TO MAKE THE OTHER PROVISIONS UNENFORCEABLE.

Exclusion of Other Warranties

THIS WARRANTY IS IN LIEU OF ALL OTHER WARRANTIES, EXPRESS OR IMPLIED, AND ALL OTHER WARRANTIES, INCLUDING BUT NOT LIMITED TO THE IMPLIED WARRANTIES OF MERCHANTABILITY AND FITNESS FOR A PARTICULAR PURPOSE, ARE EXPRESSLY DISCLAIMED.

Severability

Any provision of this warranty which is invalid, prohibited or unenforceable in any jurisdiction shall, as to such jurisdiction, be ineffective to the extent of such invalidity, prohibition or unenforceability without invalidating the remaining provisions hereof, and any such invalidity, prohibition or unenforceability in any such jurisdiction shall not invalidate or render unenforceable such provision in any other jurisdiction.

Service

For Service or Technical Assistance: Contact your TLV representative or your regional TLV office.

In Europe:

TLV EURO ENGINEERING GmbH

Daimler-Benz-Straße 16-18, 74915 Waibstadt, **Germany**

Tel: [49]-(0)7263-9150-0
Fax: [49]-(0)7263-9150-50

TLV EURO ENGINEERING UK LTD.

Units 7 & 8, Furlong Business Park, Bishops Cleeve, Gloucestershire GL52 8TW, **U.K.**

Tel: [44]-(0)1242-227223
Fax: [44]-(0)1242-223077

TLV EURO ENGINEERING FRANCE SARL

Parc d'Ariane 2, bât. C, 290 rue Ferdinand Perrier, 69800 Saint Priest, **France**

Tel: 33-(0)4-72482222
Fax: [33]-(0)4-72482220

In North America:

TLV CORPORATION

13901 South Lakes Drive, Charlotte, NC 28273-6790, **U.S.A.**

Tel: [1]-704-597-9070
Fax: [1]-704-583-1610

In Mexico and Latin America:

TLV ENGINEERING S. A. DE C. V.

Av. Jesús del Monte 39-B-1001, Col. Hda. de las Palmas, Huixquilucan, Edo. de México, 52763, **Mexico**

Tel: [52]-55-5359-7949
Fax: [52]-55-5359-7585

In Oceania:

TLV PTY LIMITED

Unit 8, 137-145 Rooks Road, Nunawading, Victoria 3131, **Australia**

Tel: [61]-(0)3-9873 5610
Fax: [61]-(0)3-9873 5010

In East Asia:

TLV PTE LTD

36 Kaki Bukit Place, #02-01/02, **Singapore** 416214

Tel: [65]-6747 4600
Fax: [65]-6742 0345

TLV SHANGHAI CO., LTD.

Room 5406, No. 103 Cao Bao Road, Shanghai, **China** 200233

Tel: [86]-(0)21-6482-8622
Fax: [86]-(0)21-6482-8623

TLV ENGINEERING SDN. BHD.

No.16, Jalan MJ14, Taman Industri Meranti Jaya, 47120 Puchong, Selangor, **Malaysia**

Tel: [60]-3-8065-2928
Fax: [60]-3-8065-2923

TLV PRIVATE LIMITED

252/94 (K-L) 17th Floor, Muang Thai-Phatra Complex Tower B, Rachadaphisek Road, Huaykwang, Bangkok 10310, **Thailand**

Tel: [66]-2-693-3799
Fax: [66]-2-693-3979

TLV INC.

#302-1 Bundang Technopark B, 723 Pangyo-ro, Bundang, Seongnam, Gyeonggi, 13511, **Korea**

Tel: [82]-(0)31-726-2105
Fax: [82]-(0)31-726-2195

In the Middle East:

TLV ENGINEERING FZCO

Building 2W, No. M002, PO Box 371684, Dubai Airport Free Zone, Dubai, **UAE**

Email: sales-me@tlv.co.jp

In Other Countries:

TLV INTERNATIONAL, INC.

881 Nagasuna, Noguchi, Kakogawa, Hyogo 675-8511, **Japan**

Tel: [81]-(0)79-427-1818
Fax: [81]-(0)79-425-1167

Manufacturer:

TLV CO., LTD.

881 Nagasuna, Noguchi, Kakogawa, Hyogo 675-8511, **Japan**

Tel: [81]-(0)79-422-1122
Fax: [81]-(0)79-422-0112