



Instruction Manual

Bypass Blow Valve **BD800**

Contents

Introduction	1
Safety Considerations	2
Specifications	4
Configuration	4
Installation	5
Operation	6
Maintenance.....	8
Disassembly/Reassembly	10
Cleaning the Valve Seat Section.....	13
Troubleshooting	14
TLV EXPRESS LIMITED WARRANTY	15
Service	17

Introduction

Thank you for purchasing the TLV bypass blow valve.

This product has been thoroughly inspected before being shipped from the factory. When the product is delivered, before doing anything else, check the specifications and external appearance to make sure nothing is out of the ordinary. Also be sure to read this manual carefully before use and follow the instructions to be sure of using the product properly.

The TLV bypass blow valve has excellent durability and reliable sealing performance in addition to a structure which can clean its seating surfaces in a simple operation. In support of this long-life product, the main components of the valve are replaceable.

In conventional valves, when dust or scale adheres to the seating surface of the valve seat section, leakage occurs eventually leading to erosion, and ultimately the valve will no longer function properly.

This bypass blow valve utilizes a special material for the valve stem and valve seat sections and together with its unique form, rotational contact between the seating surfaces scrapes off scale and restores the sealing performance of the valve.

The proven special material, combined with the unique cleaning mechanism reduces the burden of valve maintenance and operation.

If detailed instructions for special order specifications or options not contained in this manual are required, please contact TLV for full details.

This instruction manual is intended for use with the model(s) listed on the front cover. It is necessary not only for installation but for subsequent maintenance, disassembly/reassembly and troubleshooting. Please keep it in a safe place for future reference.

Safety Considerations

- Read this section carefully before use and be sure to follow the instructions.
- Installation, inspection, maintenance, repairs, disassembly, adjustment and valve opening/closing should be carried out only by trained maintenance personnel.
- The precautions listed in this manual are designed to ensure safety and prevent equipment damage and personal injury. For situations that may occur as a result of erroneous handling, three different types of cautionary items are used to indicate the degree of urgency and the scale of potential damage and danger: DANGER, WARNING and CAUTION.
- The three types of cautionary items above are very important for safety: be sure to observe all of them as they relate to installation, use, maintenance, and repair. Furthermore, TLV accepts no responsibility for any accidents or damage occurring as a result of failure to observe these precautions.

Symbols

	Indicates a DANGER, WARNING or CAUTION item.
	Indicates an urgent situation which poses a threat of death or serious injury
	Indicates that there is a potential threat of death or serious injury
	Indicates that there is a possibility of injury or equipment/product damage
	<p>DO NOT use for any other fluids than applicable fluids. DO NOT use for toxic, flammable or otherwise hazardous fluids. This product is for intended use only.</p> <p>Improper use may result in such hazards as damage to the product or malfunctions that may lead to serious accidents.</p>
	<p>Install properly and DO NOT use this product outside the recommended operating pressure, temperature and other specification ranges.</p> <p>Improper use may result in such hazards as damage to the product or malfunctions that may lead to serious accidents. Local regulations may restrict the use of this product to below the conditions quoted.</p> <p>Take measures to prevent people from coming into direct contact with product outlets.</p> <p>Failure to do so may result in burns or other injury from the discharge of fluids.</p>

Continued on the next page

 CAUTION	<p>When disassembling or removing the product, wait until the internal pressure equals atmospheric pressure and the surface of the product has cooled to room temperature. Disassembling or removing the product when it is hot or under pressure may lead to discharge of fluids, causing burns, other injuries or damage.</p>
	<p>Before using the product, ensure piping is cleaned and flushed to remove foreign matter. Failure to observe this precaution may cause leakage from the valve seat.</p>
	<p>Be sure to use only the recommended components when repairing the product, and NEVER attempt to modify the product in any way. Failure to observe these precautions may result in damage to the product and burns or other injury due to malfunction or the discharge of fluids.</p>
	<p>Do not use excessive force when connecting threaded pipes to the product. Over-tightening may cause breakage leading to fluid discharge, which may cause burns or other injury.</p>
	<p>Do not place weight on top of the spanner cap. The product is not designed to be climbed on by people. Failure to observe this precaution may result in damage to the spanner cap or injury.</p>
	<p>When using the spanner cap, be sure to use heat-resistant gloves. Disassembling or removing the product when it is hot or under pressure may lead to discharge of fluids, causing burns, other injuries or damage.</p>
	<p>Use only under conditions in which no freeze-up will occur. Freezing may damage the product, leading to fluid discharge, which may cause burns or other injury.</p>
	<p>Use only under conditions in which no water hammer will occur. The impact of water hammer may damage the product, leading to fluid discharge, which may cause burns or other injury.</p>

Specifications



DO NOT use for any other fluids than applicable fluids. **DO NOT** use for toxic, flammable or otherwise hazardous fluids. This product is for intended use only. Improper use may result in such hazards as damage to the product or malfunctions that may lead to serious accidents.



Install properly and **DO NOT** use this product outside the recommended operating pressure, temperature and other specification ranges. Improper use may result in such hazards as damage to the product or malfunctions which may lead to serious accidents. Local regulations may restrict the use of this product to below the conditions quoted.



Use only under conditions in which no freeze-up will occur. Freezing may damage the product, leading to fluid discharge, which may cause burns or other injury.

Refer to the product nameplate for detailed specifications.

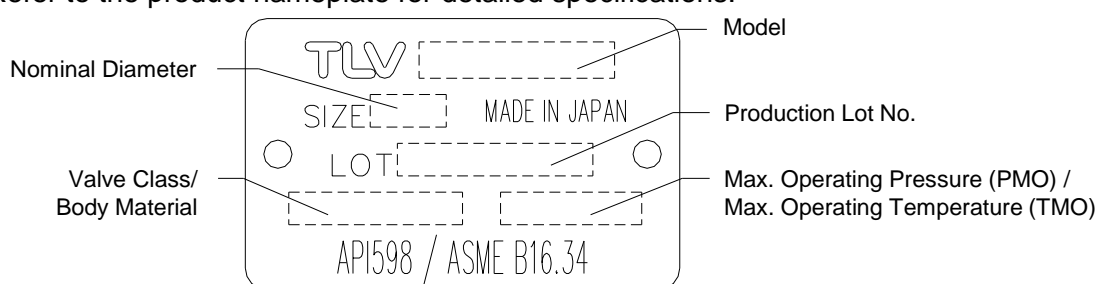

Configuration

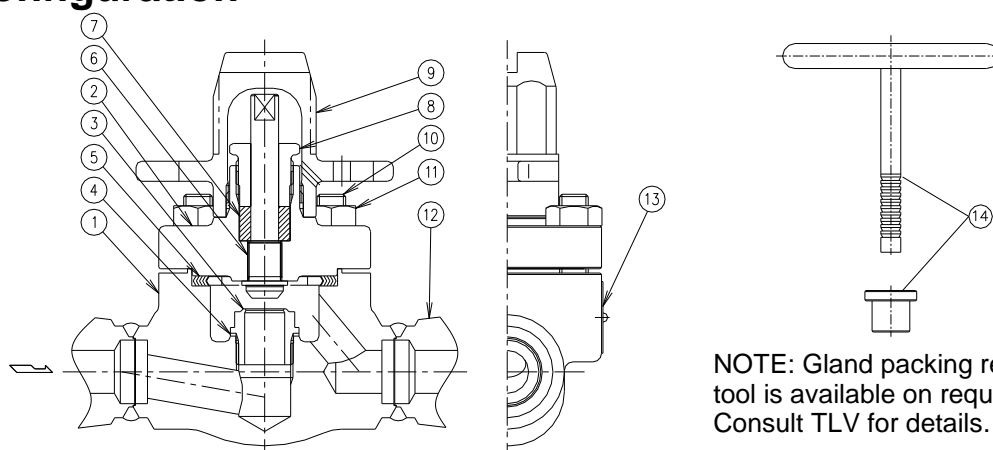

NOTE: Gland packing removal tool is available on request. Consult TLV for details.

No.	Name	M*	R*	G*	T*	No.	Name	M*	R*	G*	T*
1	Body					8	Gland Holder				
2	Bonnet					9	Spanner Cap				
3	Valve Seat		✓			10	Bonnet Bolt				
4	Valve Seat Gasket	✓	✓			11	Bonnet Nut				
5	Bonnet Gasket	✓	✓			12	Flange/Socket				
6	Valve Stem		✓			13	Nameplate				
7	Gland Packing			✓		14	Gland Packing Removal Tool				✓

*Replacement parts are available only in the following kits:

M = Maintenance kit

R = Repair kit

G = Gland packing

T = Gland packing removal tool

Installation



DO NOT use for any other fluids than applicable fluids. **DO NOT** use for toxic, flammable or otherwise hazardous fluids. This product is for intended use only. Improper use may result in such hazards as damage to the product or malfunctions that may lead to serious accidents.



Before using the product, ensure piping is cleaned and flushed to remove foreign matter. Failure to observe this precaution may cause leakage from the valve seat.



Install properly and **DO NOT** use this product outside the recommended operating pressure, temperature and other specification ranges. Improper use may result in such hazards as damage to the product or malfunctions which may lead to serious accidents. Local regulations may restrict the use of this product to below the conditions quoted.



Take measures to prevent people from coming into direct contact with product outlets. Failure to do so may result in burns or other injury from the discharge of fluids.



Do not use excessive force when connecting threaded pipes to the product. Over-tightening may cause breakage leading to fluid discharge, which may cause burns or other injury.

Installation, inspection, maintenance, repairs, disassembly, adjustment and valve opening/closing should be carried out only by trained maintenance personnel.

1. When the product is shipped from the factory, the valve stem is positioned in the lowest, valve-closed position.
2. Before installation, be sure to remove all protective seals.
3. Before installing the product, open the inlet valve and blow out the piping to remove any piping scraps, dirt and oil. Close the inlet valve after blowdown.
4. Install the product so the arrow on the body is pointing in the direction of flow.
5. Install outlet piping.

If there is a problem, determine the cause using the “Troubleshooting” section in this manual.

Operation



DO NOT use for any other fluids than applicable fluids. **DO NOT** use for toxic, flammable or otherwise hazardous fluids. This product is for intended use only. Improper use may result in such hazards as damage to the product or malfunctions that may lead to serious accidents.



Install properly and **DO NOT** use this product outside the recommended operating pressure, temperature and other specification ranges. Improper use may result in such hazards as damage to the product or malfunctions which may lead to serious accidents. Local regulations may restrict the use of this product to below the conditions quoted.



Take measures to prevent people from coming into direct contact with product outlets. Failure to do so may result in burns or other injury from the discharge of fluids.



When using the spanner cap, be sure to use heat-resistant gloves. Disassembling or removing the product when it is hot or under pressure may lead to discharge of fluids, causing burns, other injuries or damage.

Removing the Spanner Cap

Remove the spanner cap by turning it counter-clockwise.

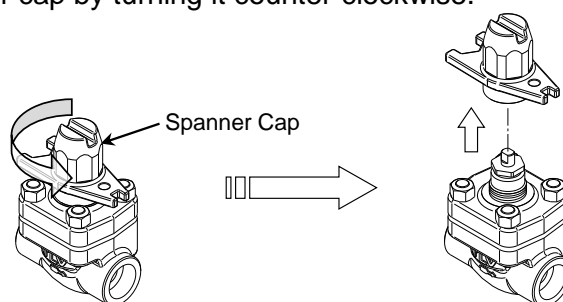

Adjusting the Valve Aperture

Place the spanner cap as shown in Figure A, adjust the valve aperture by turning the valve stem. The adjustment can also be made by using the narrow open end of the spanner cap as shown in Figure B.

NOTE: The valve stem is in a fully closed position when shipped from the factory and is tightened to a specific torque. Depending on the environment in which the product is installed, the valve stem may be difficult to adjust. In such a case, use an adjustable wrench or socket wrench to adjust the valve stem. This will make the valve stem easy to adjust with the spanner cap.

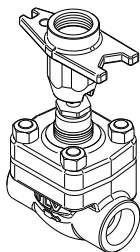

Figure A

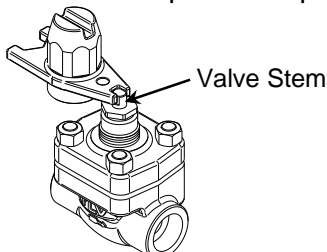

Figure B

NOTE: The valve stem can also be adjusted with an adjustable wrench, socket wrench, etc.

Distance across flats: 7 mm ($\frac{9}{32}$ in)

Restoring the Spanner Cap

Once the adjustment is made, replace the spanner cap.

This prevents unintentional change of the valve aperture. As the valve stem is covered by the spanner cap, it is protected against rainwater or foreign matter, reducing the likelihood of the valve stem sticking.

Preventing Erroneous Operation of the Valve Stem

The product is equipped with a function that prevents erroneous operation of the valve. A hole in the spanner cap allows the spanner cap to be fixed by passing a wire/steel wire and tightening it around the piping or flange as shown below. Restricting movement of the spanner cap prevents the valve from being operated erroneously.

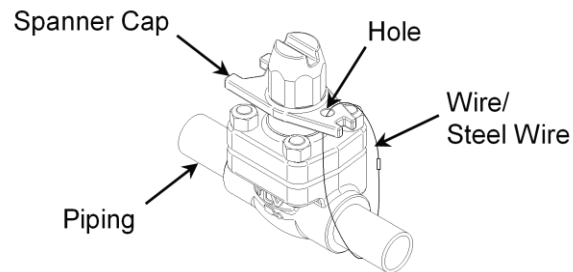

Relation between CV/Kvs Values and No. of Turns of the Valve Stem

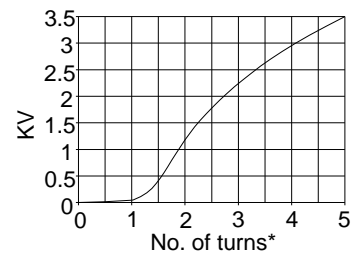
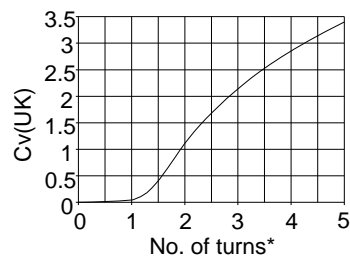
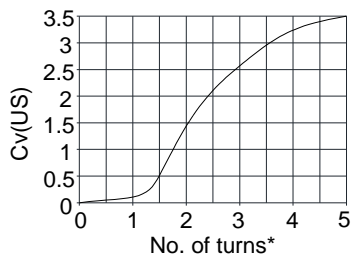

*No. of turns of the valve stem is based on the fully closed position

Maintenance



Take measures to prevent people from coming into direct contact with product outlets. Failure to do so may result in burns or other injury from the discharge of fluids.



Be sure to use only the recommended components when repairing the product, and NEVER attempt to modify the product in any way. Failure to observe these precautions may result in damage to the product or burns or other injury due to malfunction or the discharge of fluids.



Do not place weight on top of the spanner cap. The product is not designed to be climbed on by people. Failure to observe this precaution may result in damage to the spanner cap or injury.



When using the spanner cap, be sure to use heat-resistant gloves. Disassembling or removing the product when it is hot or under pressure may lead to discharge of fluids, causing burns, other injuries or damage.

Periodic Inspection

Periodic inspection for the following points is recommended at least twice per year:

- Leakage when the valve is fully closed
- Leakage from the gland holder

The spanner cap has a blow hole at the bottom. Fluid jets from the hole when there is leakage from the gland.

Take safety precautions when performing this inspection.

- Leakage from the bonnet gasket

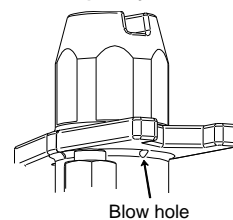

Retightening of the Gland Section

The gland holder can be retightened. When fluid leaks from the gland section, retighten the gland holder by following the steps below. Make sure that the valve is in the fully closed position when tightening the gland section.

1. Remove the spanner cap by turning it counter-clockwise.

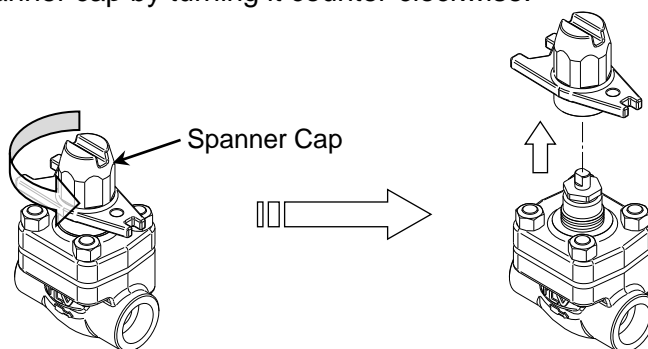

2. Tighten the gland holder.

The gland holder can be tightened with the spanner cap as well as a spanner wrench with a distance across flats of 22 mm ($\frac{7}{8}$ in). Tighten as necessary.

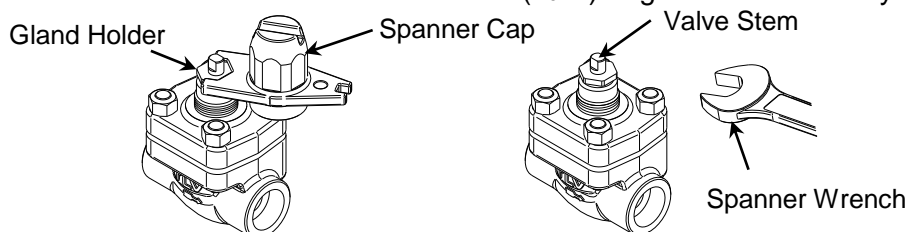

NOTE: Once leakage from the upper part of the gland holder has stopped, do not tighten any further. Make sure that the valve stem can still turn after the gland holder is tightened. Contact TLV if leakage does not stop even after retightening.

3. After retightening is complete, replace the spanner cap.

Disassembly/Reassembly



NEVER apply direct heat to the float. The float may explode due to increased internal pressure, causing accidents leading to serious injury or damage to property and equipment.



Use hoisting equipment for heavy objects (weighing approximately 20 kg (44 lb) or more). Failure to do so may result in back strain or other injury if the object should fall.



When disassembling or removing the product, wait until the internal pressure equals atmospheric pressure and the surface of the product has cooled to room temperature. Disassembling or removing the product when it is hot or under pressure may lead to discharge of fluids, causing burns, other injuries or damage.

Use the following procedures to remove components. Use the same procedures in reverse to reassemble. (Installation, inspection, maintenance, repairs, disassembly, adjustment and valve opening/closing should be carried out only by trained maintenance personnel.)

Disassembly/Reassembly of the Body/Bonnet Section

Part	During Disassembly	During Reassembly
Spanner Cap	Unscrew and remove from the bonnet	Screw onto the bonnet
Bonnet Nut	Remove with a socket wrench	Consult the table of tightening torques and tighten to the proper torque
Bonnet	Pull up and remove	Align the embossed lettering on the bonnet and body and reattach

NOTE: When assembling the bonnet to the body, tighten the bonnet nuts, making sure that the valve stem is seated on the valve seat with no built-up of rust and scale. When tightening the bonnet nuts, tighten all of them evenly and gradually to the proper torque to avoid uneven tightening. When the secondary side of the product is open to the atmosphere, visually check whether fluid is leaking on the secondary side. Contact TLV in the event leakage does not stop.

Disassembly/Reassembly of the Bonnet Section

Part	During Disassembly	During Reassembly
Gland Holder	Remove with a socket wrench	Consult the table of tightening torques and tighten to the proper torque
Valve Stem	Replace only when necessary; Unscrew from the bonnet	Screw into the bottom part of the bonnet
Gland Packing	Replace only when necessary; see the "Replacing the Gland Packing" section for replacement	Reassemble as shown in the "Replacing the Gland Packing" section

Disassembly/Reassembly of the Body Section

Part	During Disassembly	During Reassembly
Bonnet Gasket	Remove the gasket and clean sealing surfaces	Replace with a new gasket
Valve Seat	Replace with a socket wrench only when necessary	Consult the table of tightening torques and tighten to the proper torque
Valve Seat Gasket	Remove the gasket and clean sealing surfaces	Replace with a new gasket; coat surfaces with anti-seize

Table of Tightening Torques

Part Name	Torque		Distance Across Flats	
	N·m	(lbf·ft)	mm	(in)
Bonnet Nut	80	(59)	17	(²¹ / ₃₂)
Gland Holder	60	(44)	22	(⁷ / ₈)
Valve Seat	80	(59)	21	(¹³ / ₁₆)

NOTE: -Coat all threaded portions with anti-seize. (1 N·m ≈ 10 kg·cm)
 -If drawings or other special documentation were supplied for the torque given there takes precedence over values shown here.

Replacing the Gland Packing

1. Remove the valve stem then the gland holder from the bonnet.

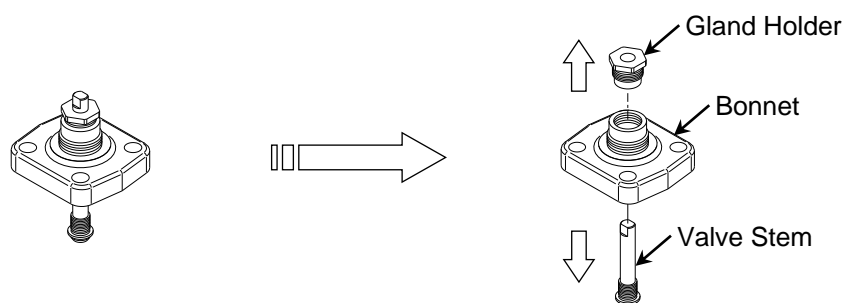

2. Insert gland packing removal tool (A) into the bonnet, then screw removal tool (B) into removal tool (A).

When removal tools (A) and (B) are inserted to the bonnet, the gland packing is caught by the tip of removal tool (A) and can be removed by lifting up the removal tool. Make sure to remove dust and scale from inside the bonnet.

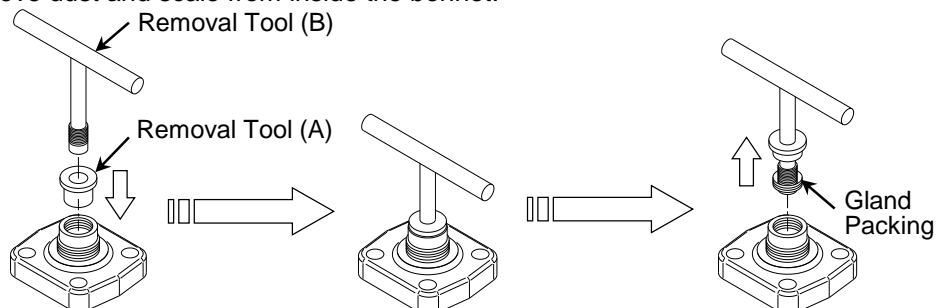

3. Reinsert the valve stem into the bonnet, then insert new gland packing into the bonnet. Align the gland packing so that the stickers face each other. After the gland packing is inserted, place removal tool (A) on top of the gland packing, and push the gland packing into position by tapping on removal tool (A) with a plastic mallet. Remove removal tool (A), replace the gland holder and tighten it to the proper torque.

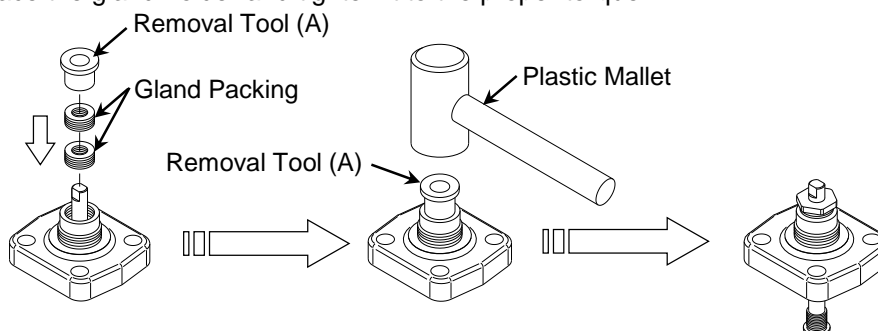

Exploded View

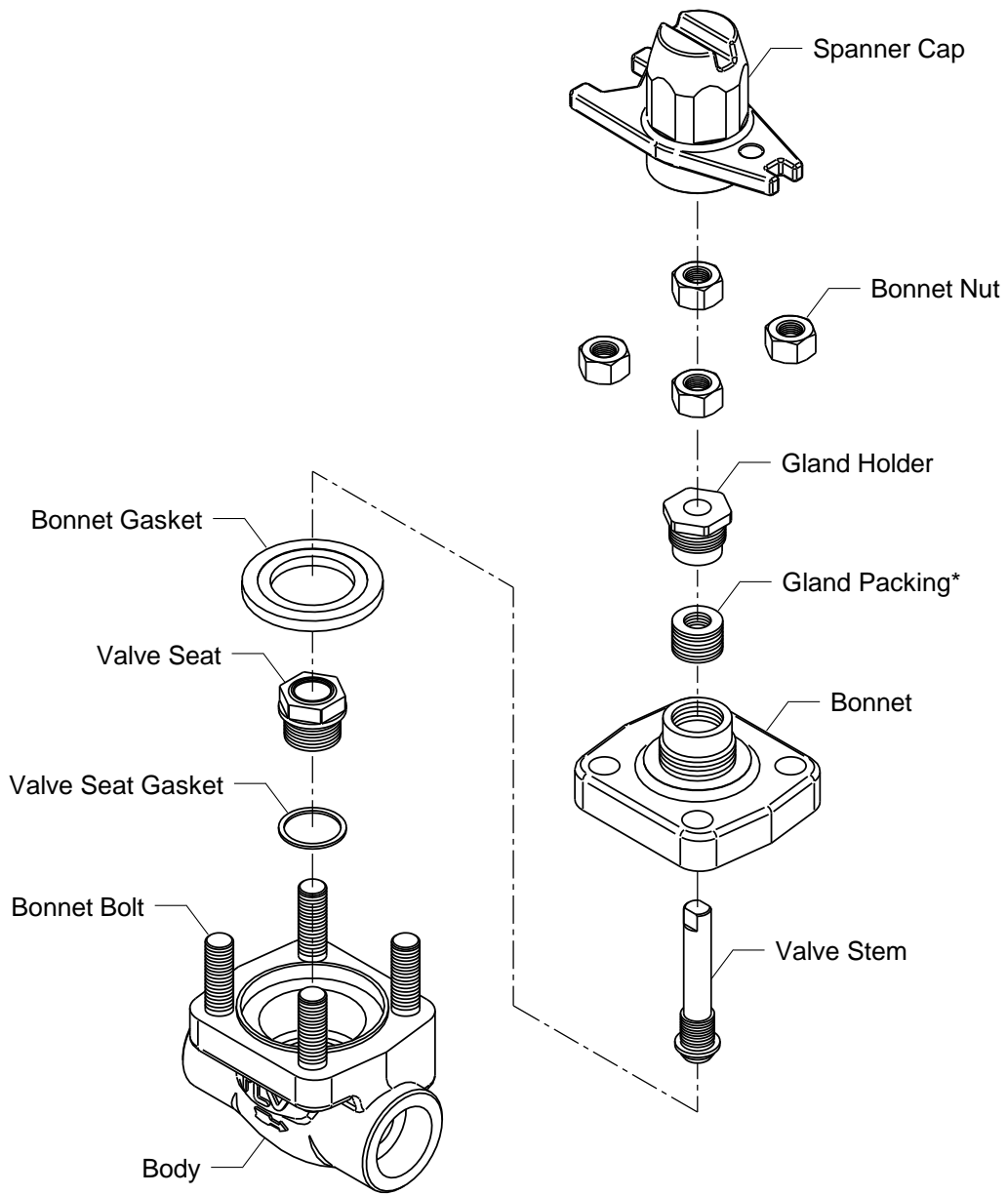

*Inlaid in the bonnet

Cleaning the Valve Seat Section



When disassembling or removing the product, wait until the internal pressure equals atmospheric pressure and the surface of the product has cooled to room temperature. Disassembling or removing the product when it is hot or under pressure may lead to discharge of fluids, causing burns, other injuries or damage.



Take measures to prevent people from coming into direct contact with product outlets. Failure to do so may result in burns or other injury from the discharge of fluids.

When scale adheres to the valve seat section, sealing is inhibited, causing fluid leakage that affects the work environment. Restore sealing performance and eliminate fluid leakage by following the steps described below.

The figure below illustrates scale accumulation between the valve seat and valve stem resulting in the valve not being able to fully close.

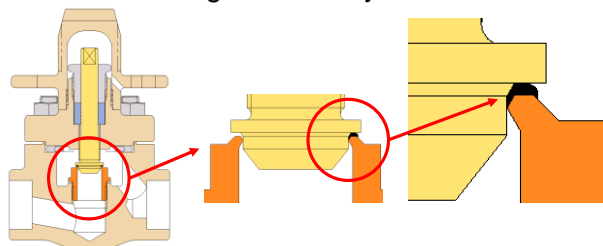

1. Remove the spanner cap.
2. Turn the valve stem counter-clockwise one to two times.
3. Turn the valve stem clockwise (right rotation) until it cannot be turned any further.
4. Repeat steps 2 and 3 two to three times. When the secondary side of the product is open to the atmosphere, visually check whether fluid is leaking on the secondary side after performing step 3.
5. When no fluid is leaking and the valve closes fully, cleaning is complete. If leakage still occurs, repeat steps 2 and 3 another two to three times.

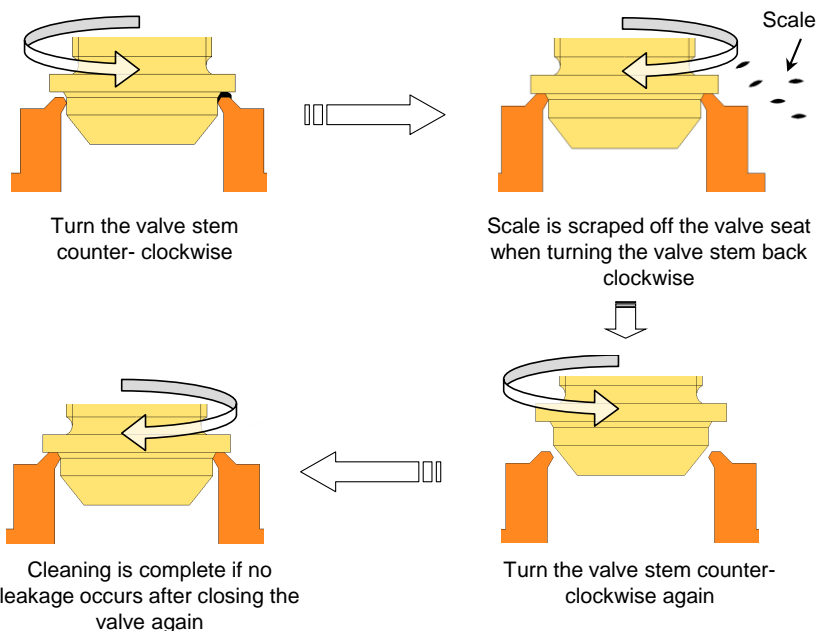

Troubleshooting



NEVER apply direct heat to the float. The float may explode due to increased internal pressure, causing accidents leading to serious injury or damage to property and equipment.



When disassembling or removing the product, wait until the internal pressure equals atmospheric pressure and the surface of the product has cooled to room temperature. Disassembling or removing the product when it is hot or under pressure may lead to discharge of fluids, causing burns, other injuries or damage.

When the product fails to operate properly, use the following table to locate the cause and remedy.

Problem	Cause	Remedy
Fluid is leaking from the outlet (even) when the valve is closed	The valve stem is not tightened sufficiently	<ul style="list-style-type: none"> Place the spanner on the flat surfaces of the valve stem and tighten it to the proper torque (16 N·m (12 lbf·ft)) Tighten the spanner cap with a spanner to the proper torque (16 N·m (12 lbf·ft))
	The sealing surfaces of the valve seat and valve stem are damaged or clogged with rust and scale (erosion, corrosion, etc.), clean those surfaces	Clean the valve seat and valve stem; if leakage does not stop after cleaning, replace with a new valve seat and/or valve stem (contact TLV)
Fluid is leaking from the gland section	The gland holder is loosened	Retighten the gland holder, clean or replace with new parts (contact TLV)
The valve stem does not move	The valve stem is clogged with rust and scale	Clean or replace with a new valve stem
Fluid is leaking from a place other than the outlet	<ul style="list-style-type: none"> Fluid is leaking from between the bonnet and body Gasket deterioration or damage The gasket sealing surfaces of the body and bonnet are damaged or clogged with rust and scale 	Replace with new gasket(s)
	Improper tightening torques were used	Tighten to the proper torque
The valve stem and the valve seat frequently become damaged	Water hammer has occurred	<ul style="list-style-type: none"> Check whether the valve stem is over-tightened; if the valve stem is deteriorated or damaged, replace with a new valve seat and/or valve stem (contact TLV) Check and correct the piping

NOTE: When replacing parts with new, use the parts list for reference, and replace with parts from the maintenance kit, repair kit, etc. Please note that replacement parts are only available as part of a replacement parts kit.

TLV EXPRESS LIMITED WARRANTY

Subject to the limitations set forth below, TLV CO., LTD., a Japanese corporation (“**TLV**”), warrants that products which are sold by it, TLV International Inc. (“**TII**”) or one of its group companies excluding TLV Corporation (a corporation of the United States of America), (hereinafter the “**Products**”) are designed and manufactured by TLV, conform to the specifications published by TLV for the corresponding part numbers (the “**Specifications**”) and are free from defective workmanship and materials. The party from whom the Products were purchased shall be known hereinafter as the “**Seller**”. With regard to products or components manufactured by unrelated third parties (the “**Components**”), TLV provides no warranty other than the warranty from the third party manufacturer(s), if any.

Exceptions to Warranty

This warranty does not cover defects or failures caused by:

1. improper shipping, installation, use, handling, etc., by persons other than TLV, TII or TLV group company personnel, or service representatives authorized by TLV; or
2. dirt, scale or rust, etc.; or
3. improper disassembly and reassembly, or inadequate inspection and maintenance by persons other than TLV or TLV group company personnel, or service representatives authorized by TLV; or
4. disasters or forces of nature or Acts of God; or
5. abuse, abnormal use, accidents or any other cause beyond the control of TLV, TII or TLV group companies; or
6. improper storage, maintenance or repair; or
7. operation of the Products not in accordance with instructions issued with the Products or with accepted industry practices; or
8. use for a purpose or in a manner for which the Products were not intended; or
9. use of the Products in a manner inconsistent with the Specifications; or
10. use of the Products with Hazardous Fluids (fluids other than steam, air, water, nitrogen, carbon dioxide and inert gases (helium, neon, argon, krypton, xenon and radon)); or
11. failure to follow the instructions contained in the TLV Instruction Manual for the Product.

Duration of Warranty

This warranty is effective for a period of one (1) year after delivery of Products to the first end user. Notwithstanding the foregoing, asserting a claim under this warranty must be brought within three (3) years after the date of delivery to the initial buyer if not sold initially to the first end user.

ANY IMPLIED WARRANTIES NOT NEGATED HEREBY WHICH MAY ARISE BY OPERATION OF LAW, INCLUDING THE IMPLIED WARRANTIES OF MERCHANTABILITY AND FITNESS FOR A PARTICULAR PURPOSE AND ANY EXPRESS WARRANTIES NOT NEGATED HEREBY, ARE GIVEN SOLELY TO THE INITIAL BUYER AND ARE LIMITED IN DURATION TO ONE (1) YEAR FROM THE DATE OF SHIPMENT BY THE SELLER.

Exclusive Remedy

THE EXCLUSIVE REMEDY UNDER THIS WARRANTY, UNDER ANY EXPRESS WARRANTY OR UNDER ANY IMPLIED WARRANTIES NOT NEGATED HEREBY (INCLUDING THE IMPLIED WARRANTIES OF MERCHANTABILITY AND FITNESS FOR A PARTICULAR PURPOSE), IS **REPLACEMENT**; PROVIDED: (a) THE CLAIMED DEFECT IS

REPORTED TO THE SELLER IN WRITING WITHIN THE WARRANTY PERIOD, INCLUDING A DETAILED WRITTEN DESCRIPTION OF THE CLAIMED DEFECT AND HOW AND WHEN THE CLAIMED DEFECTIVE PRODUCT WAS USED; AND (b) THE CLAIMED DEFECTIVE PRODUCT AND A COPY OF THE PURCHASE INVOICE IS RETURNED TO THE SELLER, FREIGHT AND TRANSPORTATION COSTS PREPAID, UNDER A RETURN MATERIAL AUTHORIZATION AND TRACKING NUMBER ISSUED BY THE SELLER. ALL LABOR COSTS, SHIPPING COSTS, AND TRANSPORTATION COSTS ASSOCIATED WITH THE RETURN OR REPLACEMENT OF THE CLAIMED DEFECTIVE PRODUCT ARE SOLELY THE RESPONSIBILITY OF BUYER OR THE FIRST END USER. THE SELLER RESERVES THE RIGHT TO INSPECT ON THE FIRST END USER'S SITE ANY PRODUCTS CLAIMED TO BE DEFECTIVE BEFORE ISSUING A RETURN MATERIAL AUTHORIZATION. SHOULD SUCH INSPECTION REVEAL, IN THE SELLER'S REASONABLE DISCRETION, THAT THE CLAIMED DEFECT IS NOT COVERED BY THIS WARRANTY, THE PARTY ASSERTING THIS WARRANTY SHALL PAY THE SELLER FOR THE TIME AND EXPENSES RELATED TO SUCH ON-SITE INSPECTION.

Exclusion of Consequential and Incidental Damages

IT IS SPECIFICALLY ACKNOWLEDGED THAT THIS WARRANTY, ANY OTHER EXPRESS WARRANTY NOT NEGATED HEREBY, AND ANY IMPLIED WARRANTY NOT NEGATED HEREBY, INCLUDING THE IMPLIED WARRANTIES OF MERCHANTABILITY AND FITNESS FOR A PARTICULAR PURPOSE, DO NOT COVER, AND NEITHER TLV, TII NOR ITS TLV GROUP COMPANIES WILL IN ANY EVENT BE LIABLE FOR, INCIDENTAL OR CONSEQUENTIAL DAMAGES, INCLUDING, BUT NOT LIMITED TO LOST PROFITS, THE COST OF DISASSEMBLY AND SHIPMENT OF THE DEFECTIVE PRODUCT, INJURY TO OTHER PROPERTY, DAMAGE TO BUYER'S OR THE FIRST END USER'S PRODUCT, DAMAGE TO BUYER'S OR THE FIRST END USER'S PROCESSES, LOSS OF USE, OR OTHER COMMERCIAL LOSSES. WHERE, DUE TO OPERATION OF LAW, CONSEQUENTIAL AND INCIDENTAL DAMAGES UNDER THIS WARRANTY, UNDER ANY OTHER EXPRESS WARRANTY NOT NEGATED HEREBY OR UNDER ANY IMPLIED WARRANTY NOT NEGATED HEREBY (INCLUDING THE IMPLIED WARRANTIES OF MERCHANTABILITY AND FITNESS FOR A PARTICULAR PURPOSE) CANNOT BE EXCLUDED, SUCH DAMAGES ARE EXPRESSLY LIMITED IN AMOUNT TO THE PURCHASE PRICE OF THE DEFECTIVE PRODUCT. THIS EXCLUSION OF CONSEQUENTIAL AND INCIDENTAL DAMAGES, AND THE PROVISION OF THIS WARRANTY LIMITING REMEDIES HEREUNDER TO REPLACEMENT, ARE INDEPENDENT PROVISIONS, AND ANY DETERMINATION THAT THE LIMITATION OF REMEDIES FAILS OF ITS ESSENTIAL PURPOSE OR ANY OTHER DETERMINATION THAT EITHER OF THE ABOVE REMEDIES IS UNENFORCEABLE, SHALL NOT BE CONSTRUED TO MAKE THE OTHER PROVISIONS UNENFORCEABLE.

Exclusion of Other Warranties

THIS WARRANTY IS IN LIEU OF ALL OTHER WARRANTIES, EXPRESS OR IMPLIED, AND ALL OTHER WARRANTIES, INCLUDING BUT NOT LIMITED TO THE IMPLIED WARRANTIES OF MERCHANTABILITY AND FITNESS FOR A PARTICULAR PURPOSE, ARE EXPRESSLY DISCLAIMED.

Severability

Any provision of this warranty which is invalid, prohibited or unenforceable in any jurisdiction shall, as to such jurisdiction, be ineffective to the extent of such invalidity, prohibition or unenforceability without invalidating the remaining provisions hereof, and any such invalidity, prohibition or unenforceability in any such jurisdiction shall not invalidate or render unenforceable such provision in any other jurisdiction.

Service

For Service or Technical Assistance: Contact your TLV representative or your regional TLV office.

In Europe:

TLV EURO ENGINEERING GmbH

Daimler-Benz-Straße 16-18, 74915 Waibstadt, **Germany**

Tel: [49]-(0)7263-9150-0

Fax: [49]-(0)7263-9150-50

TLV EURO ENGINEERING UK LTD.

Units 7 & 8, Furlong Business Park, Bishops Cleeve, Gloucestershire GL52 8TW, **U.K.**

Tel: [44]-(0)1242-227223

Fax: [44]-(0)1242-223077

TLV EURO ENGINEERING FRANCE SARL

Parc d'Ariane 2, bât. C, 290 rue Ferdinand Perrier, 69800 Saint Priest, **France**

Tel: 33-(0)4-72482222

Fax: [33]-(0)4-72482220

In North America:

TLV CORPORATION

13901 South Lakes Drive, Charlotte, NC 28273-6790, **U.S.A.**

Tel: [1]-704-597-9070

Fax: [1]-704-583-1610

In Mexico and Latin America:

TLV ENGINEERING S. A. DE C. V.

Av. Jesús del Monte 39-B-1001, Col. Hda. de las Palmas, Huixquilucan, Edo. de México, 52763, **Mexico**

Tel: [52]-55-5359-7949

Fax: [52]-55-5359-7585

In Oceania:

TLV PTY LIMITED

Unit 8, 137-145 Rooks Road, Nunawading, Victoria 3131, **Australia**

Tel: [61]-(0)3-9873 5610

Fax: [61]-(0)3-9873 5010

In East Asia:

TLV PTE LTD

36 Kaki Bukit Place, #02-01/02, **Singapore** 416214

Tel: [65]-6747 4600

Fax: [65]-6742 0345

TLV SHANGHAI CO., LTD.

Room 5406, No. 103 Cao Bao Road, Shanghai, **China** 200233

Tel: [86]-(0)21-6482-8622

Fax: [86]-(0)21-6482-8623

TLV ENGINEERING SDN. BHD.

No.16, Jalan MJ14, Taman Industri Meranti Jaya, 47120 Puchong, Selangor, **Malaysia**

Tel: [60]-3-8065-2928

Fax: [60]-3-8065-2923

TLV PRIVATE LIMITED

252/94 (K-L) 17th Floor, Muang Thai-Phatra Complex Tower B, Rachadaphisek Road, Huaykwang, Bangkok 10310, **Thailand**

Tel: [66]-2-693-3799

Fax: [66]-2-693-3979

TLV INC.

#302-1 Bundang Technopark B, 723 Pangyo-ro, Bundang, Seongnam, Gyeonggi, 13511, **Korea**

Tel: [82]-(0)31-726-2105

Fax: [82]-(0)31-726-2195

In the Middle East:

TLV ENGINEERING FZCO

Building 2W, No. M002, PO Box 371684, Dubai Airport Free Zone, Dubai, **UAE**

Email: sales-me@tlv.co.jp

In Other Countries:

TLV INTERNATIONAL, INC.

881 Nagasuna, Noguchi, Kakogawa, Hyogo 675-8511, **Japan**

Tel: [81]-(0)79-427-1818

Fax: [81]-(0)79-425-1167

Manufacturer:

TLV CO., LTD.

881 Nagasuna, Noguchi, Kakogawa, Hyogo 675-8511, **Japan**

Tel: [81]-(0)79-422-1122

Fax: [81]-(0)79-422-0112