



# Instruction Manual

Disc Type Check Valve  
**CK3M/CK3T/CK3R/CK3T-M**  
**CKF3M/CKF3R**  
**CK3MG**  
**CKF3MG/CKF3RG**

## Contents

Introduction .....	1
Safety Considerations.....	2
Specifications.....	3
Configuration.....	5
Installation.....	7
Maintenance .....	8
Disassembly/Reassembly.....	9
Troubleshooting .....	10
TLV EXPRESS LIMITED WARRANTY.....	11
Service .....	13

## Introduction

Thank you for purchasing the TLV disc type check valve.

This product has been thoroughly inspected before being shipped from the factory. When the check valve is delivered, before doing anything else, check the specifications and external appearance to make sure nothing is out of the ordinary. Also be sure to read this manual carefully before use and follow the instructions to be sure of using the product properly.

Due to its compact design, the disc type check valve can easily be installed in places where space is limited, and can be installed in either horizontal or vertical pipelines. It can be used even with an extremely low pressure differential.







If detailed instructions for special order specifications or options not contained in this manual are required, please contact TLV for full details.

This instruction manual is intended for use with the models listed on the front cover. It is necessary not only for installation but for subsequent maintenance, disassembly/reassembly and troubleshooting. Please keep it in a safe place for future reference.

## Safety Considerations

- Read this section carefully before use and be sure to follow the instructions.
- Installation, inspection, maintenance, repairs, disassembly, adjustment and valve opening/closing should be carried out only by trained maintenance personnel.
- The precautions listed in this manual are designed to ensure safety and prevent equipment damage and personal injury. For situations that may occur as a result of erroneous handling, three different types of cautionary items are used to indicate the degree of urgency and the scale of potential damage and danger: DANGER, WARNING and CAUTION.
- The three types of cautionary items above are very important for safety: be sure to observe all of them as they relate to installation, use, maintenance, and repair. Furthermore, TLV accepts no responsibility for any accidents or damage occurring as a result of failure to observe these precautions.

### Symbols

	Indicates a <b>DANGER, WARNING or CAUTION</b> item.
	Indicates an urgent situation which poses a threat of death or serious injury
	Indicates that there is a potential threat of death or serious injury
	Indicates that there is a possibility of injury or equipment / product damage
	<b>DO NOT use for toxic, flammable or otherwise hazardous fluids.</b> Use only for fluids listed in the specification table. This product is for intended use only. Improper use may result in such hazards as damage to the product or malfunctions that may lead to serious accidents.
	<b>Install properly and DO NOT use this product outside the recommended operating pressure, temperature and other specification ranges.</b> Improper use may result in such hazards as damage to the product or malfunctions that may lead to serious accidents. Local regulations may restrict the use of this product to below the conditions quoted.
	<b>When disassembling or removing the product, wait until the internal pressure equals atmospheric pressure and the surface of the product has cooled to room temperature.</b> Disassembling or removing the product when it is hot or under pressure may lead to discharge of fluids, causing burns, other injuries or damage.
	<b>Be sure to use only the recommended components when repairing the product, and NEVER attempt to modify the product in any way.</b> Failure to observe these precautions may result in damage to the product and burns or other injury due to malfunction or the discharge of fluids.
	<b>Do not use excessive force when connecting threaded pipes to the product.</b> Over-tightening may cause breakage leading to fluid discharge, which may cause burns or other injury.
	<b>Use only under conditions in which no freeze-up will occur.</b> Freezing may damage the product, leading to fluid discharge, which may cause burns or other injury.

## Specifications

**WARNING**

DO NOT use for toxic, flammable or otherwise hazardous fluids. Use only for fluids listed in the specification table. This product is for intended use only. Improper use may result in such hazards as damage to the product or malfunctions that may lead to serious accidents.

**CAUTION**

Install properly and DO NOT use this product outside the recommended operating pressure, temperature and other specification ranges. Improper use may result in such hazards as damage to the product or malfunctions which may lead to serious accidents. Local regulations may restrict the use of this product to below the conditions quoted.

**CAUTION**

Use only under conditions in which no freeze-up will occur. Freezing may damage the product, leading to fluid discharge, which may cause burns or other injury.

	Model	Size mm (in)	Body Material	Sealing Material	$\Delta P^{*1}$ MPa (psi)	Applicable Fluids	PMO <sup>*1</sup> MPaG (psig)	TMO <sup>*1</sup> °C (°F)	PMA <sup>*2</sup> MPaG (psig)	TMA <sup>*2</sup> °C (°F)	
Screwed	CK3M	15 – 25 ( $\frac{1}{2}$ – 1)	Brass	Metal <sup>*3</sup>	0.002 (0.3)	Steam	1.0 (150)	220 (428)	1.0 (150)	220 (428)	
		32 – 50 ( $\frac{1}{4}$ – 2)	Bronze				2.1 (300)		2.1 (300)		
		15 – 50 ( $\frac{1}{2}$ – 2)	Stainless Steel				1.0 (150)		1.0 (150)		
	CK3T	15 – 25 ( $\frac{1}{2}$ – 1)	Brass	PTFE <sup>*3</sup>		Steam, Water	1.0 (150)	185 (365)	1.0 (150)		
		32 – 50 ( $\frac{1}{4}$ – 2)	Bronze				1.6 (230)		2.1 (300)		
		15 – 50 ( $\frac{1}{2}$ – 2)	Stainless Steel				1.0 (150)		1.0 (150)		
	CK3R	15 – 25 ( $\frac{1}{2}$ – 1)	Brass	NBR <sup>*4</sup>		Air, Water	1.0 (150)	90 (194)	1.0 (150)		
		32 – 50 ( $\frac{1}{4}$ – 2)	Bronze				1.6 (230)		2.1 (300)		
		15 – 50 ( $\frac{1}{2}$ – 2)	Stainless Steel				0.007 (1)		0.005 (0.75)		1.0 (150)
	CK3T-M	15 ( $\frac{1}{2}$ )	Brass	PTFE <sup>*3</sup>		Steam, Water	0.001 (0.15)	2.1 (300)	220 (428)		3.2 (450)
		20,25 ( $\frac{3}{4}$ , 1)									
	CK3MG	25,40,50,80 (1, $\frac{1}{2}$ , 2, 3)	Stainless Steel	Metal <sup>*3</sup>		0.001 (0.15)	Steam, Water	3.0 (425)	350 (662)		3.0 (425)
Flangeless (Water)	CKF3M	15 – 40 ( $\frac{1}{2}$ – $1\frac{1}{2}$ )	Stainless Steel	Metal <sup>*3</sup>	0.002 (0.3)	Steam, Water	1.6 (230)	150 (302)			
	CKF3R	15 – 40 ( $\frac{1}{2}$ – $1\frac{1}{2}$ )	Stainless Steel	FPM <sup>*4</sup>		Air, Water	3.0 (425)	350 (662)			
	CKF3MG	50 – 100 (2 – 4)	Stainless Steel	Metal <sup>*3</sup>	0.001 (0.15)	Steam, Water	1.6 (230)	150 (302)			
	CKF3RG	50 (2)	Stainless Steel	FPM <sup>*4</sup>		Air, Water					

(1 MPa = 10.197 kg/cm<sup>2</sup>)

\*1  $\Delta P$  = Minimum Opening Differential Pressure; PMO = Maximum Operating Pressure; TMO = Maximum Operating Temperature

NOTE: - PMO, TMO may vary according to the options selected. Check nameplate, drawing, etc.

- When the valve has remained closed for a long period of time, the valve and the valve seat may stick, increasing the necessary minimum opening differential pressure. Make sure to open the valve properly before the installation.

In addition, the minimum opening differential pressure varies depending on the direction of flow due to the influence of the weight of the valve disc. See the table on the next page.

\*2 Maximum Allowable Pressure (PMA) and Maximum Allowable Temperature (TMA) are PRESSURE SHELL DESIGN CONDITIONS, **NOT** OPERATING CONDITIONS

\*3 PTFE = Fluorine Resin

Perfect sealing cannot be guaranteed for metal or PTFE sealing surfaces.

\*4 NBR = Nitrile Rubber; FPM = Fluorine Rubber

For rubber sealing surfaces, a closing differential pressure of more than 0.05 MPa (7 psi) will be required for perfect sealing. (However, degradation of, or debris on, the rubber sealing surface may prevent perfect sealing.)

### Minimum Opening Differential Pressure by Direction of Fluid Flow

Model		Flow Direction		Horizontal			Vertical : Upward			Vertical : Downward		
		MPa	[kPa]	(psi)	MPa	[kPa]	(psi)	MPa	[kPa]	(psi)		
CK3M/CK3T/CK3R		0.002	[2]	(0.3)	0.0015	[1.5]	(0.22)	0.0025	[2.5]	(0.40)		
CK3T-M	Size	15 (1/2)	0.007	[7]	(1)	0.0065	[6.5]	(0.94)	0.0075	[7.5]	(1.10)	
	mm (in)	20, 25 (3/4, 1)	0.005	[5]	(0.75)	0.0045	[4.5]	(0.65)	0.0055	[5.5]	(0.80)	
CK3MG		0.001	[1]	(0.15)	0.0005	[0.5]	(0.07)	0.0015	[1.5]	(0.22)		
CKF3M/CKF3R		0.002	[2]	(0.3)	0.0016	[1.6]	(0.23)	0.0024	[2.4]	(0.35)		
CKF3MG/CKF3RG		0.001	[1]	(0.15)	0.0005	[0.5]	(0.07)	0.0015	[1.5]	(0.22)		

### Cv Values

Model	Size	mm (in)	15	20	25	32	40	50	65	80	100
			(1/2)	(3/4)	(1)	(1 1/4)	(1 1/2)	(2)	(2 1/2)	(3)	(4)
CK3M/ CK3T/ CK3R	Cv (US)		3.7	6.6	10	15	21	29	—		
	Cv (UK)		3.1	5.5	8.3	13	17	24	—		
	Kvs (DIN)		3.2	5.7	8.6	13	18	25	—		
CK3T-M	Cv (US)		3.7	6.6	10	—					
	Cv (UK)		3.1	5.5	8.3	—					
	Kvs (DIN)		3.2	5.7	8.6	—					
CK3MG	Cv (US)		—		25	—	55	91	—	180	—
	Cv (UK)		—		21	—	46	76	—	150	—
	Kvs (DIN)		—		21	—	47	78	—	154	—
CKF3M/ CKF3R	Cv (US)		4.6	8.8	16	20	29	—			
	Cv (UK)		3.8	7.3	13	17	24	—			
	Kvs (DIN)		3.9	7.5	14	17	25	—			
CKF3MG	Cv (US)		—				—	54	100	140	240
	Cv (UK)		—				—	45	83	117	200
	Kvs (DIN)		—				—	46	85	120	206
CKF3RG	Cv (US)		—				—	54	—		
	Cv (UK)		—				—	45	—		
	Kvs (DIN)		—				—	46	—		

### Connectable Flange Standards

(This applies to the flangeless connections; CKF3M, CKF3R, CKF3MG and CKF3RG)

Size	JIS	ASME / JPI	PN (EN/DIN)	BS TABLE
15 (1/2)	5,10,16,20,30K	Class 150,300	PN 6,10,16,25,40	A,D,E,F,H,J
20 (3/4)				
25 (1)				
32 (1 1/4)				
40 (1 1/2)				
50 (2)				
65 (2 1/2)	10,16,20,30K	Class 125,150,250,300	PN 10,16,25,40	F,H,J
80 (3)				
100 (4)				

### Options

Model	ΔP Minimum Opening Differential Pressure
CK3M/CK3T/CK3R	MPa
	(psi)
CKF3M/CKF3R	MPa
	(psi)

\*Except nominal size of 40 mm (1 1/2 in) for ΔP 0.01 MPa (1.5 psi).

Model	Rubber Sealing Material
CK3R	Fluorine Rubber (FPM) — TMO 150 °C (302 °F)

Special use	As a vacuum breaker*
-------------	----------------------

\*CK3R, CKF3R and CKF3RG (with rubber sealing) should not be used.

Due to the nature of the rubber, there is a possibility of the disc sticking to the metal valve seat, compromising product performance at the very low differential pressures under which vacuum breakers operate.

## Configuration

### CK3M/CK3T/CK3R/CK3T-M

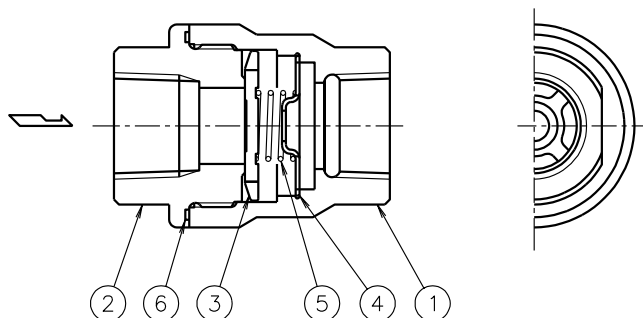

No.	Name	M*	R*
1	Body		
2	Inlet Union		
3	Valve Disc		✓
4	Spring Holder		
5	Coil Spring		✓
6	Union Gasket	✓	✓

\*Replacement parts are available only in the following kits:  
 M = Maintenance Kit  
 R = Repair Kit

NOTE: - When requesting a Repair Kit, please specify the minimum opening differential pressure.

- For nominal sizes 15 – 25 mm (1/2 – 1 in), confirm that an identification code of "A" or later is present on the nameplate as shown in the figure below when requesting replacement parts. Both Maintenance Kit and Repair Kit will be available for products with such a code. If no such code is shown on the nameplate, please contact TLV.

- For nominal sizes 32 – 50 mm (1 1/4 – 2 in), both Maintenance Kit and Repair Kit are available regardless of identification code.

Location of identification code on nameplate

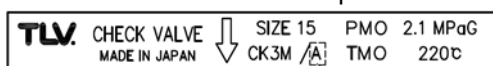

Identification Code

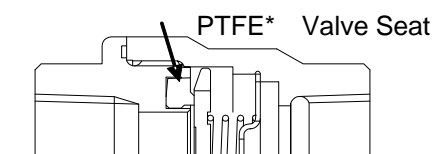

\* PTFE = Fluorine Resin

The CK3T, CK3T-M inlet union has a PTFE valve seat insert.

Rubber Sealing

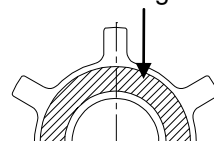

CK3R valve disc is inlaid with rubber.

### CK3MG

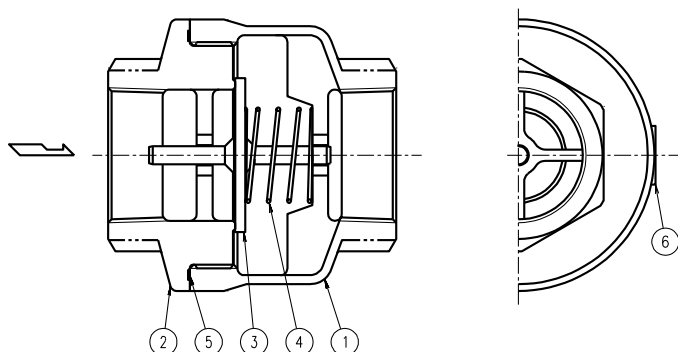

No.	Name	M*	R*
1	Body		
2	Inlet Union		
3	Valve Disc		✓
4	Coil Spring		✓
5	Union Gasket	✓	✓
6	Nameplate		

\*Replacement parts are available only in the following kits:  
 M = Maintenance Kit  
 R = Repair Kit

NOTE: When requesting a Repair Kit, please specify the minimum opening differential pressure.

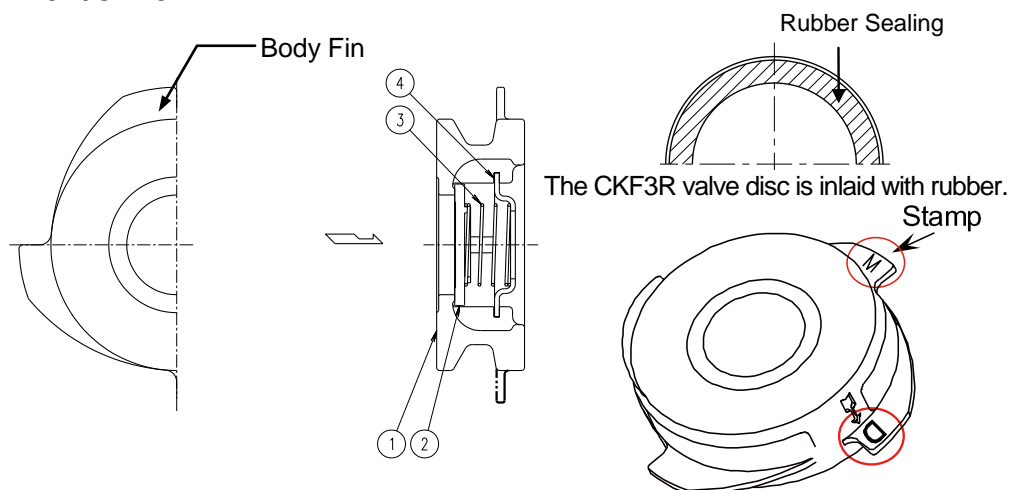
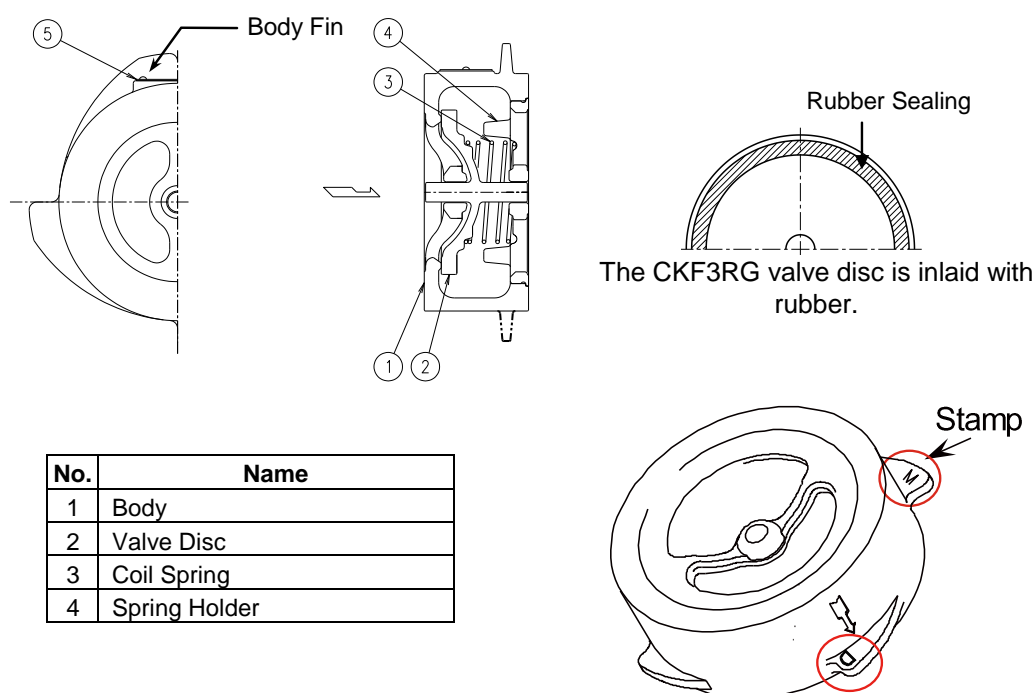
**CKF3M/CKF3R****CKF3MG/CKF3RG**

No.	Name
1	Body
2	Valve Disc
3	Coil Spring
4	Spring Holder

Replacement parts are not available for CKF3 series (flangeless) check valves, as special equipment is required for assembly / disassembly.

Sealing material and flange face finish can be identified by a stamp on the body fin. The flange face finish is stamped for DIN serration only, with the "D" mark.

Mark	Model	Sealing Material	Mark	Flange Face Finish
M	CKF3M CKF3MG	Metal	—	- Surface roughness: 3.2 – 6.3 $\mu\text{mRa}$ (125 – 250 AARH) Serration - ASME B16.5 Serration
F	CKF3R CKF3RG	Fluorine Rubber (FPM) (Standard)	D	DIN Serration
N		Nitrile Rubber (NBR)*		
E		Ethylene Propylene Rubber (EPDM)*		

\*Optional or special order materials

## Installation



**WARNING**

DO NOT use for toxic, flammable or otherwise hazardous fluids. Use only for fluids listed in the specification table. This product is for intended use only. Improper use may result in such hazards as damage to the product or malfunctions that may lead to serious accidents.

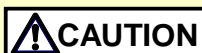

**CAUTION**

Install properly and DO NOT use this product outside the recommended operating pressure, temperature and other specification ranges. Improper use may result in such hazards as damage to the product or malfunctions which may lead to serious accidents. Local regulations may restrict the use of this product to below the conditions quoted.



**CAUTION**

Do not use excessive force when connecting threaded pipes to the product. Over-tightening may cause breakage leading to fluid discharge, which may cause burns or other injury.

Installation, inspection, maintenance, repairs, disassembly, adjustment and valve opening/closing should be carried out only by trained maintenance personnel.

1. Avoid installation directly after equipment that may cause sudden changes in pressure or flow including water hammer and pulsation. (For example: high flow ON-OFF valves or pumps that start and stop frequently) Strong shocks to internal parts may result in damage to the spring or premature wear on the disc valve and seating surfaces.
2. Temperature:

Maximum Operating Temperature	Model				
	350 °C (662 °F)	CKF3M CKF3MG ↓	CK3M CK3MG ↓	CK3T CK3T-M ↓	CKF3R CKF3RG ↓
220 °C (428 °F)					
185 °C (365 °F)					
150 °C (302 °F)					
90 °C (194 °F)					

- NOTE: 1. Choose the model that meets operating temperature requirements  
2. The CK3R optional FPM sealing model can be used to 150 °C (302 °F)

3. Before installation, be sure to remove all protective seals.
4. Before installing the product, blow out the inlet piping to remove any piping scraps, dirt and oil. Close the inlet valve after blowdown.
5. Before installing the product, open the valve to make sure that the valve and the valve seat do not stick to each other.
6. Install the product so the arrow on the body is pointing in the direction of flow.
7. There are no restrictions on the direction of installation, however vertical piping installation is recommended. To center the valve, install the CKF3M(R) and the CKF3M(R)G with the bolts touching the fins (see the figure shown above).
8. When installing a screwed type, secure the inlet and outlet piping of the product using supports, etc. to ensure that it does not place stress on the inlet union or the body of the product.
9. Open the inlet valve, and perform the necessary checks to make sure that the product functions properly.

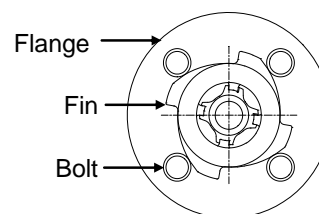

If there is a problem, determine the cause using the “Troubleshooting” section in this manual.



## Maintenance



Be sure to use only the recommended components when repairing the product, and NEVER attempt to modify the product in any way. Failure to observe these precautions may result in damage to the product or burns or other injury due to malfunction or the discharge of fluids.

### Operational Check

A visual inspection of the following items should be done on a daily basis to determine whether the product is operating properly or has failed. Periodically (at least biannually) the operation should also be checked using diagnostic equipment, such as a stethoscope.

If the product should fail, it may cause damage to piping and equipment, resulting in faulty or low quality products.

**Normal** : Where inlet pressure is higher than outlet pressure (equal to or greater than the minimum opening differential pressure), flow, in the proper direction, can be verified.

If outlet pressure becomes higher than inlet pressure, flow ceases.

**Leakage** : There is flow even when outlet pressure becomes higher than inlet pressure.

### Parts Inspection

When parts have been removed, or during periodic inspections, use the following table to inspect the parts and replace any that are found to be defective.

Procedure	
Gaskets:	Check for warping or damage
Valve Disc:	Check for scratches
Inlet Union Sealing Surfaces:	Check for scratches
Coil Spring:	Check for scratches or wear
(After cleaning inside the body)	
Spring Holder:	Check for scratches or wear

## Disassembly/Reassembly



When disassembling or removing the product, wait until the internal pressure equals atmospheric pressure and the surface of the product has cooled to room temperature. Disassembling or removing the product when it is hot or under pressure may lead to discharge of fluids, causing burns, other injuries or damage.

Use the following procedures to remove components. Use the same procedures in reverse to reassemble. (Installation, inspection, maintenance, repairs, disassembly, adjustment and valve opening/closing should be carried out only by trained maintenance personnel.)

### Disassembly/Reassembly of Check Valve

#### CK3M/CK3T/CK3R/CK3T-M

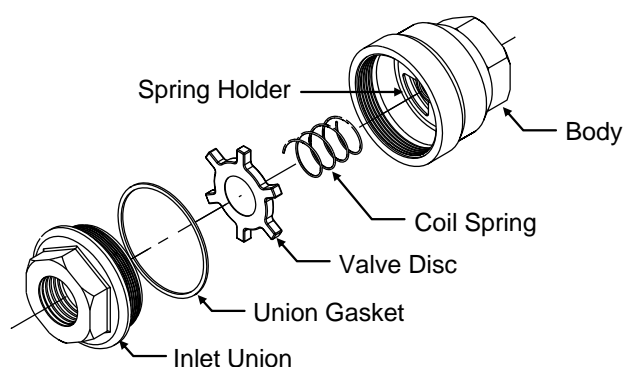

#### CK3MG

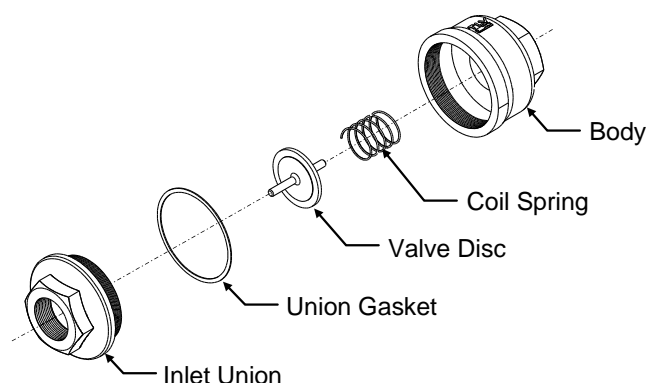

Part	During Disassembly	During Reassembly
Inlet Union	Remove with a wrench	Coat threads with anti-seize and tighten to the proper torque
Union Gasket	Remove the union gasket	Replace with a new gasket if warped or damaged; make sure the gasket does not get pinched when tightening the inlet union
Valve Disc	Remove the valve disc	Insert, making sure the polished surface is facing the inlet union
Coil Spring	Remove the coil spring	CK3M/CK3T/CK3R/CK3T-M: Insert into housing CK3MG: Place the coil spring on the disc stem
Spring Holder (not CK3MG)	This part is inserted tightly in the body, and is not meant to be removed	—

#### CKF3M/CKF3R/CKF3MG/CKF3RG

Assembly/disassembly are not possible for these models as special equipment is required. Accordingly, replacement parts are not available for these models.

## Table of Tightening Torques

### Inlet Union

Model	CK3M/CK3T/CK3R/CK3T-M				CK3MG					
	Size		Torque		Distance Across Flats		Torque		Distance Across Flats	
	mm	(in)	N·m	(lbf·ft)	mm	(in)	N·m	(lbf·ft)	mm	(in)
15		(1/2)	100	(73)	27	(1 <sup>1</sup> / <sub>16</sub> )	—	—	—	—
20		(3/4)	150	(110)	32	(1 <sup>1</sup> / <sub>4</sub> )	—	—	—	—
25		(1)	180	(130)	41	(1 <sup>5</sup> / <sub>8</sub> )	180	(130)	41	(1 <sup>5</sup> / <sub>8</sub> )
32		(1 <sup>1</sup> / <sub>4</sub> )	250	(185)	50	(1 <sup>31</sup> / <sub>32</sub> )	—	—	—	—
40		(1 <sup>1</sup> / <sub>2</sub> )	300	(220)	55	(2 <sup>5</sup> / <sub>32</sub> )	600	(440)	60	(2 <sup>3</sup> / <sub>8</sub> )
50		(2)	400	(290)	70	(2 <sup>3</sup> / <sub>4</sub> )	800	(590)	75	(2 <sup>15</sup> / <sub>16</sub> )
80		(3)	—	—	—	100			(3 <sup>15</sup> / <sub>16</sub> )	

(1 N·m ≈ 10 kg·cm)

NOTE: If drawings or other special documentation were supplied for the product, any torque given there takes precedence over values shown here.

## Troubleshooting



When disassembling or removing the product, wait until the internal pressure equals atmospheric pressure and the surface of the product has cooled to room temperature. Disassembling or removing the product when it is hot or under pressure may lead to discharge of fluids, causing burns, other injuries or damage.

When the product fails to operate properly, use the following table to locate the cause and remedy.

Problem	Cause	Remedy	
		Screwed	Flangeless
The sound of flow can be heard when the outlet pressure is higher than inlet pressure	Dirt or damage on sealing surfaces or build-up inside the body	Clean parts	
	The valve disc is catching due to wear, dirt, rust, etc.	Replace with a new check valve	
	The coil spring is dislodged or broken	Replace with a new coil spring	Replace with a new check valve
	The spring holder is dislodged or broken	Replace with a new check valve	
Leakage to the outside of the check valve	The union gasket is warped or damaged	Replace with a new gasket	—
	Incorrect inlet union tightening torque	Tighten to the proper torque	—
	The check valve is subject to stress from the piping (weight, torsion, etc.)	Correct the piping	—
Flow is poor	The valve disc is catching due to wear, dirt, rust, etc.	Clean parts	
	Incorrect operating pressure	Adjust by increasing the pressure or replace with a check valve that has a larger Cv value	
The valve does not open at the specified differential pressure	Sticking of the valve and the valve seat due to rust, pipe sealing agent, etc.	Clean parts	
		If the valve disc is inlaid with rubber, it may be the case that the rubber is sticking to the metal. Contact TLV for details.	

NOTE: When replacing parts with new, use the parts list for reference and replace with parts from the Maintenance Kit, Repair Kit, etc. (Please note that replacement parts are only available in pre-packaged kits.)

## TLV EXPRESS LIMITED WARRANTY

Subject to the limitations set forth below, TLV CO., LTD., a Japanese corporation (“**TLV**”), warrants that products which are sold by it, TLV International Inc. (“**TII**”) or one of its group companies excluding TLV Corporation (a corporation of the United States of America), (hereinafter the “**Products**”) are designed and manufactured by TLV, conform to the specifications published by TLV for the corresponding part numbers (the “**Specifications**”) and are free from defective workmanship and materials. The party from whom the Products were purchased shall be known hereinafter as the “**Seller**”. With regard to products or components manufactured by unrelated third parties (the “**Components**”), TLV provides no warranty other than the warranty from the third party manufacturer(s), if any.

### Exceptions to Warranty

This warranty does not cover defects or failures caused by:

1. improper shipping, installation, use, handling, etc., by persons other than TLV, TII or TLV group company personnel, or service representatives authorized by TLV; or
2. dirt, scale or rust, etc.; or
3. improper disassembly and reassembly, or inadequate inspection and maintenance by persons other than TLV or TLV group company personnel, or service representatives authorized by TLV; or
4. disasters or forces of nature or Acts of God; or
5. abuse, abnormal use, accidents or any other cause beyond the control of TLV, TII or TLV group companies; or
6. improper storage, maintenance or repair; or
7. operation of the Products not in accordance with instructions issued with the Products or with accepted industry practices; or
8. use for a purpose or in a manner for which the Products were not intended; or
9. use of the Products in a manner inconsistent with the Specifications; or
10. use of the Products with Hazardous Fluids (fluids other than steam, air, water, nitrogen, carbon dioxide and inert gases (helium, neon, argon, krypton, xenon and radon)); or
11. failure to follow the instructions contained in the TLV Instruction Manual for the Product.

### Duration of Warranty

This warranty is effective for a period of one (1) year after delivery of Products to the first end user. Notwithstanding the foregoing, asserting a claim under this warranty must be brought within three (3) years after the date of delivery to the initial buyer if not sold initially to the first end user.

ANY IMPLIED WARRANTIES NOT NEGATED HEREBY WHICH MAY ARISE BY OPERATION OF LAW, INCLUDING THE IMPLIED WARRANTIES OF MERCHANTABILITY AND FITNESS FOR A PARTICULAR PURPOSE AND ANY EXPRESS WARRANTIES NOT NEGATED HEREBY, ARE GIVEN SOLELY TO THE INITIAL BUYER AND ARE LIMITED IN DURATION TO ONE (1) YEAR FROM THE DATE OF SHIPMENT BY THE SELLER.

### Exclusive Remedy

THE EXCLUSIVE REMEDY UNDER THIS WARRANTY, UNDER ANY EXPRESS WARRANTY OR UNDER ANY IMPLIED WARRANTIES NOT NEGATED HEREBY (INCLUDING THE IMPLIED WARRANTIES OF MERCHANTABILITY AND FITNESS FOR A PARTICULAR PURPOSE), IS **REPLACEMENT**; PROVIDED: (a) THE CLAIMED DEFECT IS REPORTED TO THE SELLER IN WRITING WITHIN THE WARRANTY PERIOD, INCLUDING A DETAILED WRITTEN DESCRIPTION OF THE CLAIMED DEFECT AND HOW AND WHEN THE CLAIMED DEFECTIVE PRODUCT WAS USED; AND (b) THE CLAIMED DEFECTIVE PRODUCT AND A COPY OF THE PURCHASE INVOICE IS RETURNED TO

THE SELLER, FREIGHT AND TRANSPORTATION COSTS PREPAID, UNDER A RETURN MATERIAL AUTHORIZATION AND TRACKING NUMBER ISSUED BY THE SELLER. ALL LABOR COSTS, SHIPPING COSTS, AND TRANSPORTATION COSTS ASSOCIATED WITH THE RETURN OR REPLACEMENT OF THE CLAIMED DEFECTIVE PRODUCT ARE SOLELY THE RESPONSIBILITY OF BUYER OR THE FIRST END USER. THE SELLER RESERVES THE RIGHT TO INSPECT ON THE FIRST END USER'S SITE ANY PRODUCTS CLAIMED TO BE DEFECTIVE BEFORE ISSUING A RETURN MATERIAL AUTHORIZATION. SHOULD SUCH INSPECTION REVEAL, IN THE SELLER'S REASONABLE DISCRETION, THAT THE CLAIMED DEFECT IS NOT COVERED BY THIS WARRANTY, THE PARTY ASSERTING THIS WARRANTY SHALL PAY THE SELLER FOR THE TIME AND EXPENSES RELATED TO SUCH ON-SITE INSPECTION.

#### **Exclusion of Consequential and Incidental Damages**

IT IS SPECIFICALLY ACKNOWLEDGED THAT THIS WARRANTY, ANY OTHER EXPRESS WARRANTY NOT NEGATED HEREBY, AND ANY IMPLIED WARRANTY NOT NEGATED HEREBY, INCLUDING THE IMPLIED WARRANTIES OF MERCHANTABILITY AND FITNESS FOR A PARTICULAR PURPOSE, DO NOT COVER, AND NEITHER TLV, TII NOR ITS TLV GROUP COMPANIES WILL IN ANY EVENT BE LIABLE FOR, INCIDENTAL OR CONSEQUENTIAL DAMAGES, INCLUDING, BUT NOT LIMITED TO LOST PROFITS, THE COST OF DISASSEMBLY AND SHIPMENT OF THE DEFECTIVE PRODUCT, INJURY TO OTHER PROPERTY, DAMAGE TO BUYER'S OR THE FIRST END USER'S PRODUCT, DAMAGE TO BUYER'S OR THE FIRST END USER'S PROCESSES, LOSS OF USE, OR OTHER COMMERCIAL LOSSES. WHERE, DUE TO OPERATION OF LAW, CONSEQUENTIAL AND INCIDENTAL DAMAGES UNDER THIS WARRANTY, UNDER ANY OTHER EXPRESS WARRANTY NOT NEGATED HEREBY OR UNDER ANY IMPLIED WARRANTY NOT NEGATED HEREBY (INCLUDING THE IMPLIED WARRANTIES OF MERCHANTABILITY AND FITNESS FOR A PARTICULAR PURPOSE) CANNOT BE EXCLUDED, SUCH DAMAGES ARE EXPRESSLY LIMITED IN AMOUNT TO THE PURCHASE PRICE OF THE DEFECTIVE PRODUCT. THIS EXCLUSION OF CONSEQUENTIAL AND INCIDENTAL DAMAGES, AND THE PROVISION OF THIS WARRANTY LIMITING REMEDIES HEREUNDER TO REPLACEMENT, ARE INDEPENDENT PROVISIONS, AND ANY DETERMINATION THAT THE LIMITATION OF REMEDIES FAILS OF ITS ESSENTIAL PURPOSE OR ANY OTHER DETERMINATION THAT EITHER OF THE ABOVE REMEDIES IS UNENFORCEABLE, SHALL NOT BE CONSTRUED TO MAKE THE OTHER PROVISIONS UNENFORCEABLE.

#### **Exclusion of Other Warranties**

THIS WARRANTY IS IN LIEU OF ALL OTHER WARRANTIES, EXPRESS OR IMPLIED, AND ALL OTHER WARRANTIES, INCLUDING BUT NOT LIMITED TO THE IMPLIED WARRANTIES OF MERCHANTABILITY AND FITNESS FOR A PARTICULAR PURPOSE, ARE EXPRESSLY DISCLAIMED.

#### **Severability**

Any provision of this warranty which is invalid, prohibited or unenforceable in any jurisdiction shall, as to such jurisdiction, be ineffective to the extent of such invalidity, prohibition or unenforceability without invalidating the remaining provisions hereof, and any such invalidity, prohibition or unenforceability in any such jurisdiction shall not invalidate or render unenforceable such provision in any other jurisdiction.

## Service

For Service or Technical Assistance: Contact your TLV representative or your regional TLV office.

### In Europe:

#### **TLV EURO ENGINEERING GmbH**

Daimler-Benz-Straße 16-18, 74915 Waibstadt, **Germany**

Tel: [49]-(0)7263-9150-0  
Fax: [49]-(0)7263-9150-50

#### **TLV EURO ENGINEERING UK LTD.**

Units 7 & 8, Furlong Business Park, Bishops Cleeve, Gloucestershire GL52 8TW, **U.K.**

Tel: [44]-(0)1242-227223  
Fax: [44]-(0)1242-223077

#### **TLV EURO ENGINEERING FRANCE SARL**

Parc d'Ariane 2, bât. C, 290 rue Ferdinand Perrier, 69800 Saint Priest, **France**

Tel: [33]-(0)4-72482222  
Fax: [33]-(0)4-72482220

### In North America:

#### **TLV CORPORATION**

13901 South Lakes Drive, Charlotte, NC 28273-6790, **U.S.A.**

Tel: [1]-704-597-9070  
Fax: [1]-704-583-1610

### In Mexico and Latin America:

#### **TLV ENGINEERING S. A. DE C. V.**

Av. Jesús del Monte 39-B-1001, Col. Hda. de las Palmas, Huixquilucan, Edo. de México, 52763, **Mexico**

Tel: [52]-55-5359-7949  
Fax: [52]-55-5359-7585

### In Oceania:

#### **TLV PTY LIMITED**

Unit 8, 137-145 Rooks Road, Nunawading, Victoria 3131, **Australia**

Tel: [61]-(0)3-9873 5610  
Fax: [61]-(0)3-9873 5010

### In East Asia:

#### **TLV PTE LTD**

36 Kaki Bukit Place, #02-01/02, **Singapore** 416214

Tel: [65]-6747 4600  
Fax: [65]-6742 0345

#### **TLV SHANGHAI CO., LTD.**

Room 5406, No. 103 Cao Bao Road, Shanghai, **China** 200233

Tel: [86]-(0)21-6482-8622  
Fax: [86]-(0)21-6482-8623

#### **TLV ENGINEERING SDN. BHD.**

No.16, Jalan MJ14, Taman Industri Meranti Jaya, 47120 Puchong, Selangor, **Malaysia**

Tel: [60]-3-8065-2928  
Fax: [60]-3-8065-2923

#### **TLV PRIVATE LIMITED**

252/94 (K-L) 17th Floor, Muang Thai-Phatra Complex Tower B, Rachadaphisek Road, Huaykwang, Bangkok 10310, **Thailand**

Tel: [66]-2-693-3799  
Fax: [66]-2-693-3979

#### **TLV INC.**

#302-1 Bundang Technopark B, 723 Pangyo-ro, Bundang, Seongnam, Gyeonggi, 13511, **Korea**

Tel: [82]-(0)31-726-2105  
Fax: [82]-(0)31-726-2195

### In the Middle East:

#### **TLV ENGINEERING FZCO**

Building 2W, No. M002, PO Box 371684, Dubai Airport Free Zone, Dubai, **UAE**

Email: sales-me@tlv.co.jp

### In Other Countries:

#### **TLV INTERNATIONAL, INC.**

881 Nagasuna, Noguchi, Kakogawa, Hyogo 675-8511, **Japan**

Tel: [81]-(0)79-427-1818  
Fax: [81]-(0)79-425-1167

### Manufacturer:

#### **TLV CO., LTD.**

881 Nagasuna, Noguchi, Kakogawa, Hyogo 675-8511, **Japan**

Tel: [81]-(0)79-422-1122  
Fax: [81]-(0)79-422-0112