



FREE FLOAT® STEAM TRAP

MODEL SJH7 CAST STEEL

FREE FLOAT STEAM TRAP WITH THREE-POINT SEATING AND THERMOSTATIC AIR VENTING

Features

Reliable and durable steam trap with tight shut-off for use on medium high pressure, high temperature process equipment. Models for horizontal or vertical piping installation.

1. Self-modulating free float provides continuous, smooth, low velocity condensate discharge as process loads vary.
2. Precision-ground float, constant water seal and three-point seating design ensure a steam-tight seal, even under no-load conditions.
3. Thermostatic bimetal air vent valve vents air automatically for rapid startup.
4. Built-in screen with large surface area ensures extended trouble-free operation.
5. Easy, inline access to internal parts simplifies cleaning and reduces maintenance costs.

Pressure Equipment Directive (PED)

Classification according to PED 2014/68/EU, fluid group 2

Size	Category	CE marking
DN 40, DN 50	I	with CE marking and Declaration of Conformity



Specifications

Model	SJH7N		SJH7V
	Horizontal		Vertical
Installation	Flanged PN 63		Flanged PN 25/40
Connection	DN 40, 50		DN 40, 50
Size	32, 46		5, 10, 14, 22, 32
Orifice No.	32, 46		5, 10, 14, 22, 32
Maximum Operating Pressure (barg) PMO	32, 46		5, 10, 14, 22, 32
Maximum Differential Pressure (bar) Δ PMX	32, 46		5, 10, 14, 22, 32
Maximum Operating Temperature (°C) TMO	400		400

PRESSURE SHELL DESIGN CONDITIONS (NOT OPERATING CONDITIONS):
 Maximum Allowable Pressure (barg) PMA: 40 (65 for PN 63 flange connection)
 Maximum Allowable Temperature (°C) TMA: 400

1 bar = 0.1 MPa



To avoid abnormal operation, accidents or serious injury, DO NOT use this product outside of the specification range. Local regulations may restrict the use of this product to below the conditions quoted.

No.	Description	Material	DIN*	ASTM/AISI*
①	Body	PN 25/40 Cast Steel A216 Gr.WCB	1.0619	—
		PN 63 Cast Steel A217 Gr.WC6	1.7357	—
②	Cover	PN 25/40 Carbon Steel A105	1.0460	—
		PN 63 Cast Steel A217 Gr.WC6	1.7357	—
③	Float	Stainless Steel SUS316L	1.4404	AISI316L
④	Orifice	—	—	—
⑤	Orifice Gasket	Graphite/Stainl. St. SUS316L	-/1.4404	-/AISI316L
⑥	Orifice Plug Gasket (SJH7N)	Soft Iron SUYP	1.1121	AISI1010
⑦	Orifice Plug (SJH7N)	Cast Stainl. St. A351 Gr.CF8	1.4312	—
⑧	Cover Gasket	Graphite/Stainl. St. SUS316L	-/1.4404	-/AISI316L
⑨	Cover Bolt	Alloy Steel SNB7	1.7225	A193 Gr.B7
⑩	Cover Nut	Carbon Steel S45C	1.0503	AISI1045
⑪	Screen Holder Gasket	Soft Iron SUYP	1.1121	AISI1010
⑫	Screen Holder	Cast Stainl. St. A351 Gr.CF8	1.4312	—
⑬	Screen	Stainless Steel SUS430	1.4016	AISI430
⑭	Plug Cover Gasket	Soft Iron SUYP	1.1121	AISI1010
⑮	Plug Cover	Cast Stainl. St. A351 Gr.CF8	1.4312	—
⑯	Plug	Stainless Steel SUS420F	1.4028	AISI420F
⑰	Guide	Stainless Steel SUS304	1.4301	AISI304
⑱	Air Vent Strip	Bimetal	—	—
⑲	Screw with Washer	Stainless Steel SUS304	1.4301	AISI304
⑳	Nameplate	Stainless Steel SUS304	1.4301	AISI304

* Equivalent materials

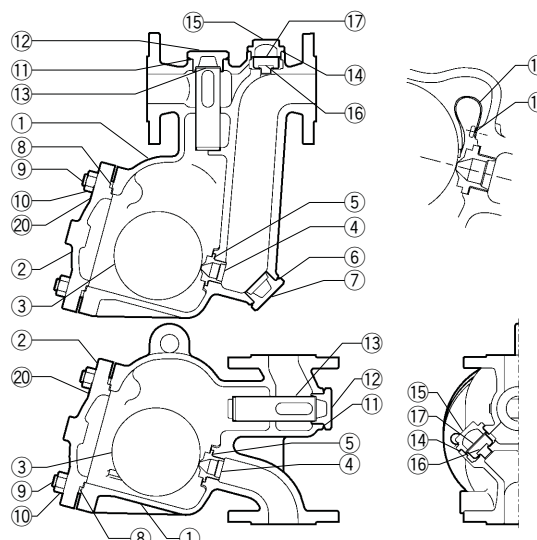

Copyright © TLV

Dimensions

● **SJH7N Flanged**

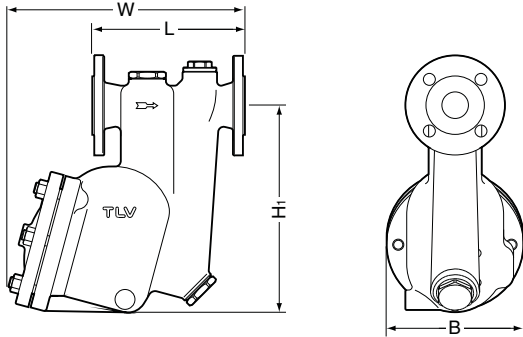

SJH7N Flanged (mm)

DN	L		H ₁	W	B	Weight (kg)
	DIN 2501	PN63				
	PN25/40					
40	230	246	315	360	205	32 [33]
50		242				[370] [365]

[] PN63

● **SJH7V Flanged**

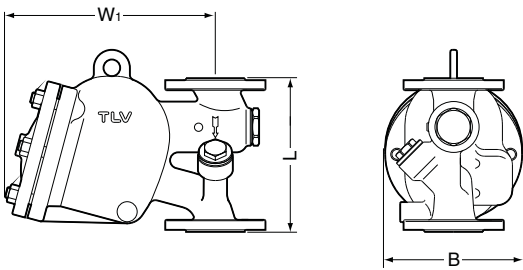

SJH7V Flanged (mm)

DN	L		W ₁	B	Weight (kg)
	DIN 2501	PN25/40			
40	230		315	205	27
50					29

Discharge Capacity

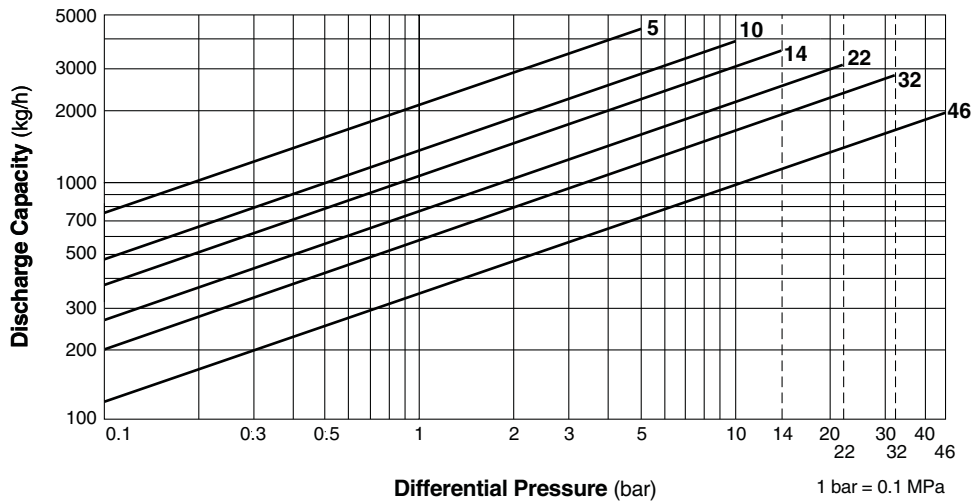

1. Line numbers within the graph refer to orifice numbers.
2. Differential pressure is the difference between the inlet and outlet pressure of the trap.
3. Capacities are based on continuous discharge of condensate 6 °C below saturated steam temperature.
4. Recommended safety factor: at least 1.5.



DO NOT use this product under conditions that exceed maximum differential pressure, as condensate backup will occur!

Manufacturer

TLV CO., LTD.
Kakogawa, Japan
is approved by LRQA Ltd. to ISO 9001/14001

ISO 9001
ISO 14001

