



Manufacturer

TLV CO., LTD.

Kakogawa, Japan

is approved by LRDA Ltd. to ISO 9001/14001



Instruction Manual

Bypass Blowdown Steam Trap
BT3N / MBT3N / PBT3N

Copyright © 2021 by TLV CO., LTD.

All rights reserved

Contents

Introduction	1
Safety Considerations	2
Checking the Piping	4
Operation	5
Specifications	6
Configuration	8
Installation and Operation	11
Manual Operation.....	15
Maintenance.....	16
Disassembly / Reassembly	19
Troubleshooting	24
TLV EXPRESS LIMITED WARRANTY	27
Service	29

Introduction

Thank you for purchasing the TLV bypass blowdown steam trap.

This product has been thoroughly inspected before being shipped from the factory. When the product is delivered, before doing anything else, check the specifications and external appearance to make sure nothing is out of the ordinary. Also be sure to read this manual carefully before use and follow the instructions to be sure of using the trap properly.

The TLV bypass blowdown steam trap features a combination of: the most reliable of steam traps, the free float; a compact ball valve, with superior long-lasting sealing properties; and an actuator unit (electric, pneumatic).

The following models are contained in this manual:

BT3N: Steam trap with an integrated compact bypass blowdown ball valve with a manual operation handle

MBT3N: Steam trap with an integrated compact bypass blowdown ball valve with an electric actuator

PBT3N: Steam trap with an integrated compact bypass blowdown ball valve with a pneumatic actuator





If detailed instructions for special order specifications or options not contained in this manual are required, please contact TLV for full details.



This instruction manual is intended for use with the model(s) listed on the front cover. It is necessary not only for installation but for subsequent maintenance, disassembly/reassembly and troubleshooting. Please keep it in a safe place for future reference.

Safety Considerations

- Read this section carefully before use and be sure to follow the instructions.
- Installation, inspection, maintenance, repairs, disassembly, adjustment and valve opening/closing should be carried out only by trained maintenance personnel.
- The precautions listed in this manual are designed to ensure safety and prevent equipment damage and personal injury. For situations that may occur as a result of erroneous handling, three different types of cautionary items are used to indicate the degree of urgency and the scale of potential damage and danger: DANGER, WARNING and CAUTION.
- The three types of cautionary items above are very important for safety: be sure to observe all of them as they relate to installation, use, maintenance, and repair. Furthermore, TLV accepts no responsibility for any accidents or damage occurring as a result of failure to observe these precautions.

Symbols

	Indicates a DANGER, WARNING or CAUTION item.
	Indicates an urgent situation which poses a threat of death or serious injury
	Indicates that there is a potential threat of death or serious injury
	Indicates that there is a possibility of injury or equipment / product damage

	NEVER apply direct heat to the float. The float may explode due to increased internal pressure, causing accidents leading to serious injury or damage to property and equipment.
	Install properly and DO NOT use this product outside the recommended operating pressure, temperature and other specification ranges. Improper use may result in such hazards as damage to the product or malfunctions that may lead to serious accidents. Local regulations may restrict the use of this product to below the conditions quoted.
	DO NOT use this product in excess of the maximum operating pressure differential. Such use could make discharge impossible (blocked).
	Take measures to prevent people from coming into direct contact with product outlets. Failure to do so may result in burns or other injury from the discharge of fluids.
	When disassembling or removing the product, wait until the internal pressure equals atmospheric pressure and the surface of the product has cooled to room temperature. Disassembling or removing the product when it is hot or under pressure may lead to discharge of fluids, causing burns, other injuries or damage.

Continued on the next page

 CAUTION	<p>Be sure to use only the recommended components when repairing the product, and NEVER attempt to modify the product in any way. Failure to observe these precautions may result in damage to the product and burns or other injury due to malfunction or the discharge of fluids.</p>
	<p>Do not use excessive force when connecting threaded pipes to the product. Over-tightening may cause breakage leading to fluid discharge, which may cause burns or other injury.</p>
	<p>Use only under conditions in which no freeze-up will occur. Freezing may damage the product, leading to fluid discharge, which may cause burns or other injury.</p>
	<p>Use only under conditions in which no water hammer will occur. The impact of water hammer may damage the product, leading to fluid discharge, which may cause burns or other injury.</p>
	<p>Do not stand on or apply body weight to the handle. The handle may break, resulting in injury or other accidents.</p>
	<p>Make sure the power supply is OFF before carrying out work on the wiring or inspections involving disassembly. If such work is carried out with the power on, there is a danger that equipment may malfunction or electric shock may occur, leading to injury or other accidents.</p>
	<p>Make sure that wiring work requiring a special license is carried out only by qualified personnel. If carried out by unqualified personnel, overheating or short circuits leading to injury, fires, damage or other accidents may occur.</p>
	<p>When using this product, NEVER stand close to, or leave tools anywhere near moving parts such as the shaft. Contact with moving parts or objects becoming caught in moving parts could lead to injury, damage or other accidents.</p>

Checking the Piping



Use only under conditions in which no water hammer will occur. The impact of water hammer may damage the product, leading to fluid discharge, which may cause burns or other injury.

Check to make sure that the pipes to be connected to the trap have been installed properly.

1. Is the pipe diameter suitable?
2. Has sufficient space been secured for maintenance? (Refer to step 3. in the "Installation" section.)
3. Are the inlet and outlet connections on the same horizontal plane?
4. Have maintenance valves been installed at the inlet and outlet? If the outlet is subject to back pressure, has a check valve (TLV-CK) been installed?
5. Is the inlet pipe as short as possible, with as few bends as possible, and installed so the liquid will flow naturally down into the trap?
6. Has the piping work been done with the proper methods, shown in the figures below?

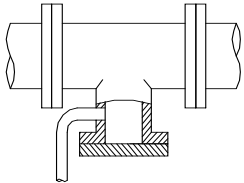
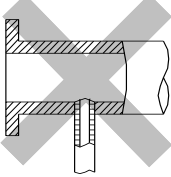
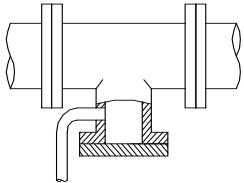
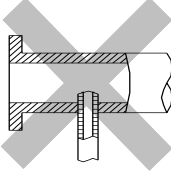
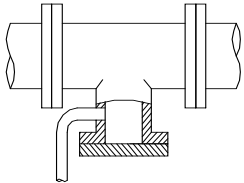
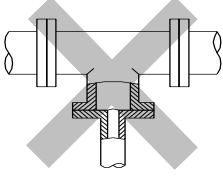
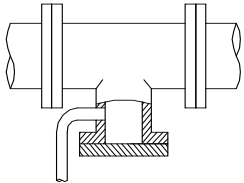
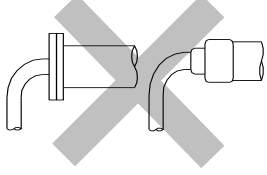
Requirement	Correct	Incorrect
Install catchpot with the proper diameter.		 Diameter is too small.
Make sure the flow of condensate is not obstructed.		 Diameter is too small and inlet protrudes into pipe interior.
To prevent rust and scale from flowing into the trap, the inlet pipe should be connected 25 - 50 mm above the base of the T-pipe.		 Rust and scale flow into the trap with the condensate.
When installing on the blind end, make sure the flow of condensate is not obstructed.		 Condensate collects in the pipe.

Operation

1. At start-up, the bypass blowdown valve can be opened to allow a large quantity of condensate to be rapidly discharged, minimizing the time required for the unit to warm up. The bimetal holds the float away from the orifice so that initial air in the trap chamber is also discharged.
2. After the blowdown operation ends, the bimetal strip retracts and the valve closes, the float automatically adjusts the valve opening in response to the fluctuation in load, and the condensate is continuously discharged – no condensate will accumulate ahead of the steam trap.
3. When the amount of condensate flowing into the chamber decreases, the float gradually closes the orifice. Steam leakage is prevented through the use of a 3-point seating design and the water sealing of the valve. Normally the bimetal remains retracted and has no effect on the operation of the float, but if air should accumulate in the trap and the temperature drops, it extends, forcing the float up and the air is automatically vented.

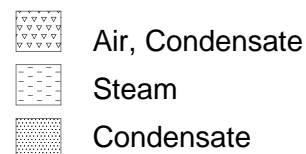
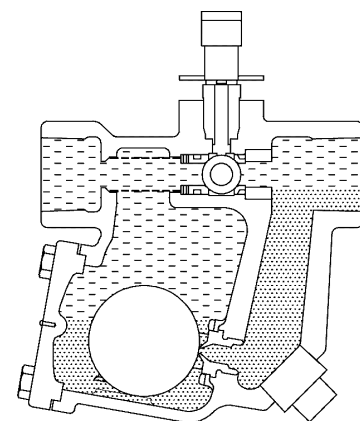
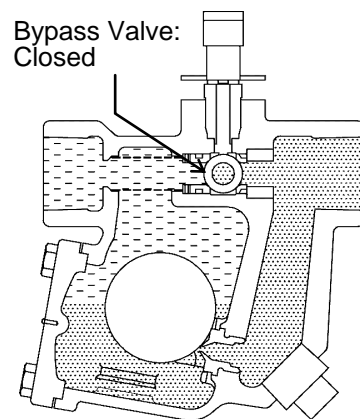
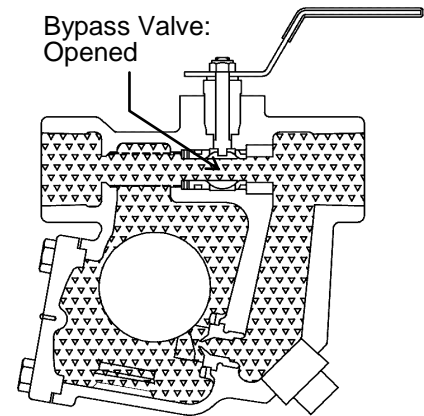

Specifications



Install properly and **DO NOT** use this product outside the recommended operating pressure, temperature and other specification ranges. Improper use may result in such hazards as damage to the product or malfunctions which may lead to serious accidents. Local regulations may restrict the use of this product to below the conditions quoted.



DO NOT use this product in excess of the maximum operating pressure differential; such use could make discharge impossible (blocked).



Use only under conditions in which no freeze-up will occur. Freezing may damage the product, leading to fluid discharge, which may cause burns or other injury.

Steam Trap Body

Refer to the product nameplate for detailed specifications.

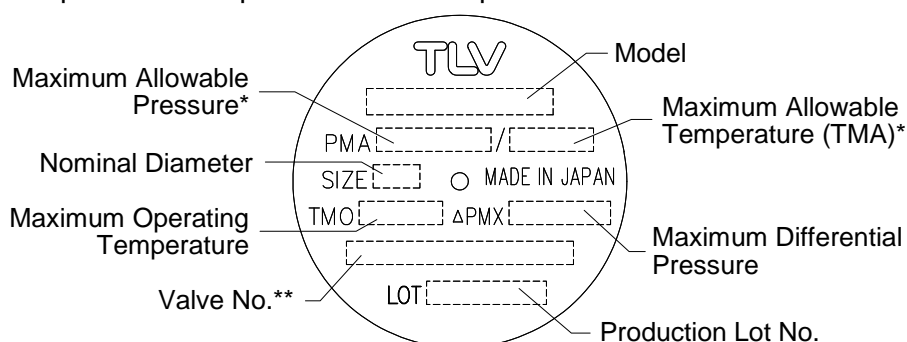

* Maximum allowable pressure (PMA) and maximum allowable temperature (TMA) are PRESSURE SHELL DESIGN CONDITIONS, **NOT** OPERATING CONDITIONS.

** Valve No. is displayed for products with options. This item is omitted from the nameplate when there are no options.

MBT3N: Motor Unit

Motor Type	Reversible motor (condenser run type single-phase induction motor)
Power Consumption	52 VA (100 - 110 V), 62 VA (200 - 220 V)
Control System	ON-OFF (fully open/fully closed)
Overload Protection	Built-in thermal protector 120±5 °C
Direction of Rotation	90° reciprocating
Open/Close Time (90° rotation)	3.5 seconds/50 Hz 3.0 seconds/60 Hz
Water Resistance	Rainproof
Manual Override	Possible when the power is OFF
Ambient Temp. Range and Operation Cycles (within 1 cm of the trap cover)	<div style="display: flex; justify-content: space-around; align-items: flex-start;"> <div style="text-align: center;"> <p>0.5 MPaG Steam</p> <p>1.0 MPaG Steam</p> </div> <div style="text-align: center;"> <p>Operation Cycle*</p> <p>A: Closed-to-open B: Open-to-closed</p> </div> </div> <p>**"Operation cycle" is the interval between the motor stop at the end of one open or close operation and the motor start at the beginning of the next.</p> <p>Example: When the ambient temperature is 40 °C, and the medium in use is steam at 0.5 MPaG, allow for a cycle operation interval of at least 36 seconds. When the cycle operation interval is less than 36 seconds, a thermal protector will prevent the motor unit from operating until it cools down sufficiently.</p>

(1 MPa = 10.197 kg/cm²)

PBT3N: Actuator Unit

Actuator Type	Vane rotary actuator
Air Supply Pressure	0.3 - 1.0 MPaG
Air Supply Port Size	Rc(PT) ^{1/8}
Control System	ON-OFF (fully open/fully closed) reciprocating
Open/Close Time (90° rotation)	0.09 - 0.8 seconds
Actuator Capacity	42 cm ³
Ambient Temp. Range	60 °C or lower
Water Resistance	Rainproof
Manual Override	Possible in absence of motive pressure
Air Consumption (Graph represents consumption for one reciprocating cycle)	<p style="text-align: center;">(kg/cm²G)</p> <p style="text-align: center;">Air Consumption (N litre)</p> <p style="text-align: center;">Air Supply Pressure (MPaG)</p>

(1 MPa = 10.197 kg/cm²)

Configuration

BT3N

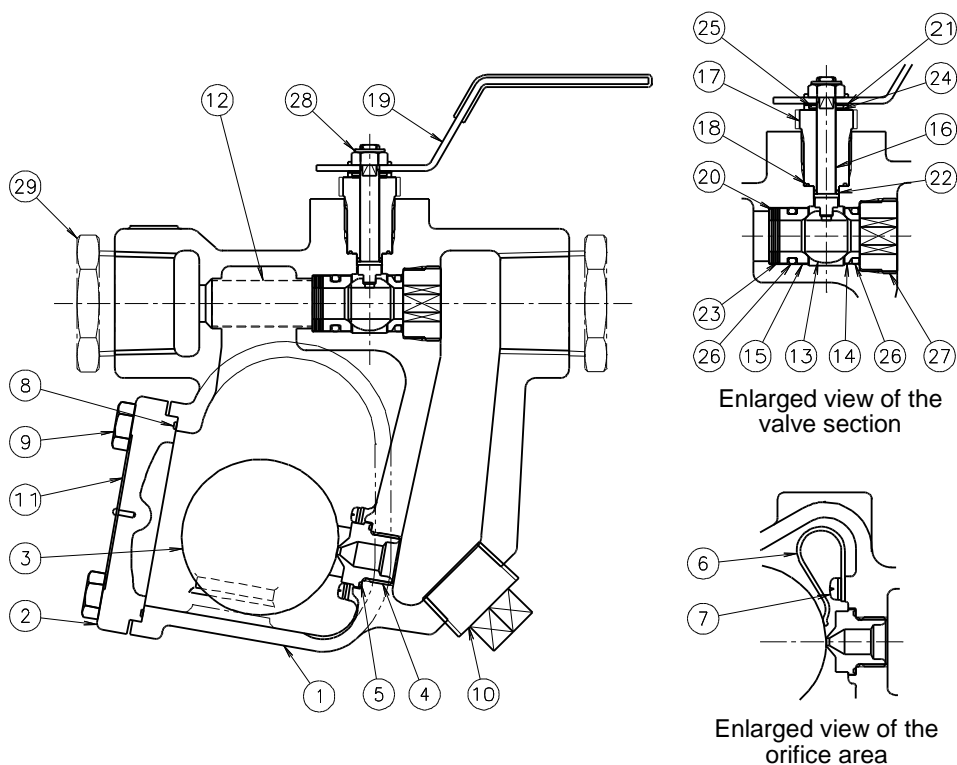

NOTE: Removing the handle or locknut causes degradation of the gland section seal. Do not remove the handle or locknut except when performing a disassembly inspection.

No.	Name	No.	Name	No.	Name
1	Body	11	Nameplate	21	Disc Spring
2	Cover	12	Screen	22	Gland Packing
3	Float	13	Ball	23	Washer
4	Orifice	14	Outlet Valve Seat	24	Thrust Washer
5	Orifice Gasket	15	Inlet Valve Seat	25	Washer
6	Air Vent Strip (Bimetal)	16	Spindle	26	O-ring (Inlet/Outlet Valve Seat)
7	Screw & Spring Washer	17	Gland	27	Valve Holder
8	Cover Gasket	18	Gland Gasket	28	Locknut
9	Cover Bolt	19	Handle	29	Bushing*
10	Orifice Plug	20	Disc Spring		

* Included only with 15 and 20 mm sizes.

MBT3N

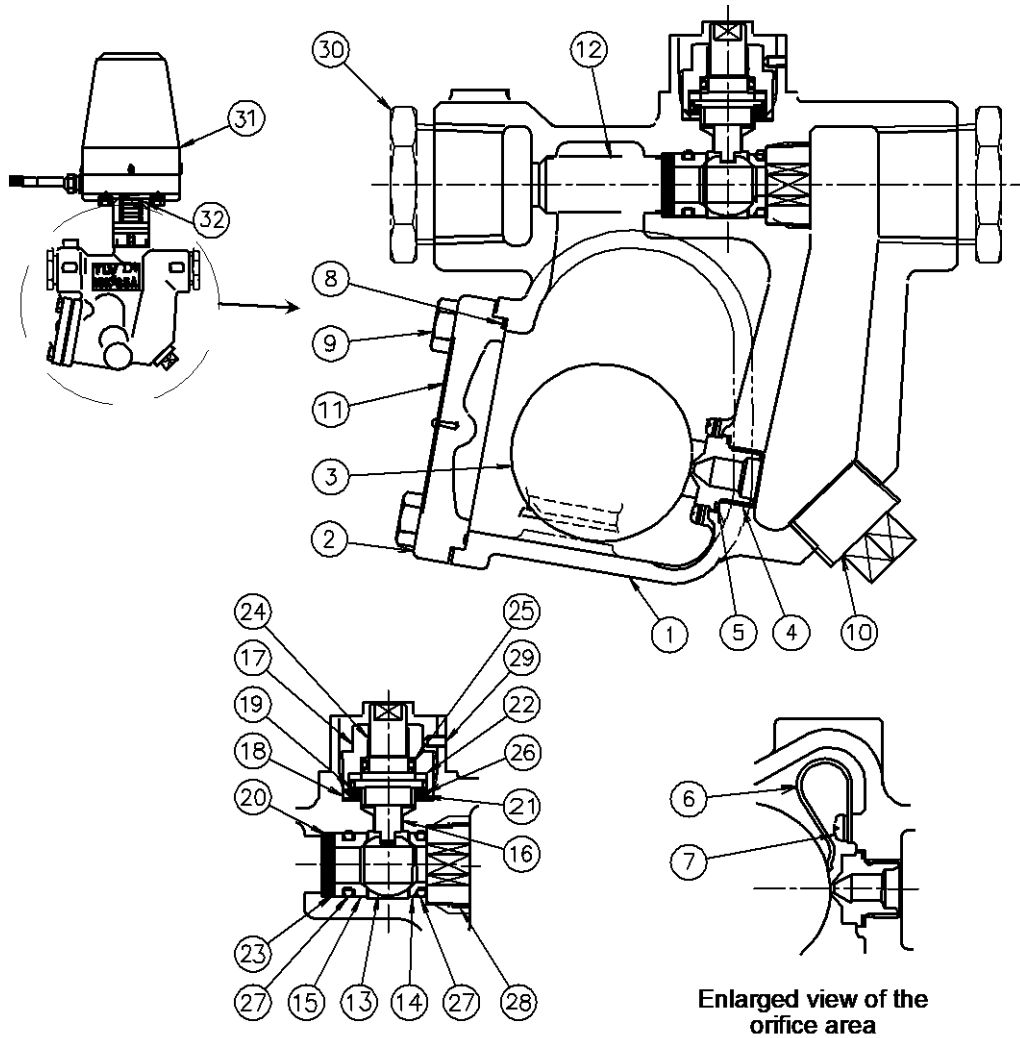

Enlarged view of the valve section

Enlarged view of the orifice area

No.	Name	No.	Name	No.	Name
1	Body	13	Ball	25	Seal
2	Cover	14	Outlet Valve Seat	26	Washer
3	Float	15	Inlet Valve Seat	27	O-ring (Inlet/Outlet Valve Seat)
4	Orifice	16	Spindle	28	Valve Holder
5	Orifice Gasket	17	Gland Holder	29	Holder Screw (Gland Holder)
6	Air Vent Strip (Bimetal)	18	Gland Holder Gasket	30	Bushing*
7	Screw & Spring Washer	19	Gland Seat	31	Motor Unit
8	Cover Gasket	20	Disc Spring	32	Shaft Coupling
9	Cover Bolt	21	Disc Spring		
10	Orifice Plug	22	Gland Packing		
11	Nameplate	23	Washer		
12	Screen	24	Guide Bushing		

* Included only with 15 and 20 mm sizes.

PBT3N

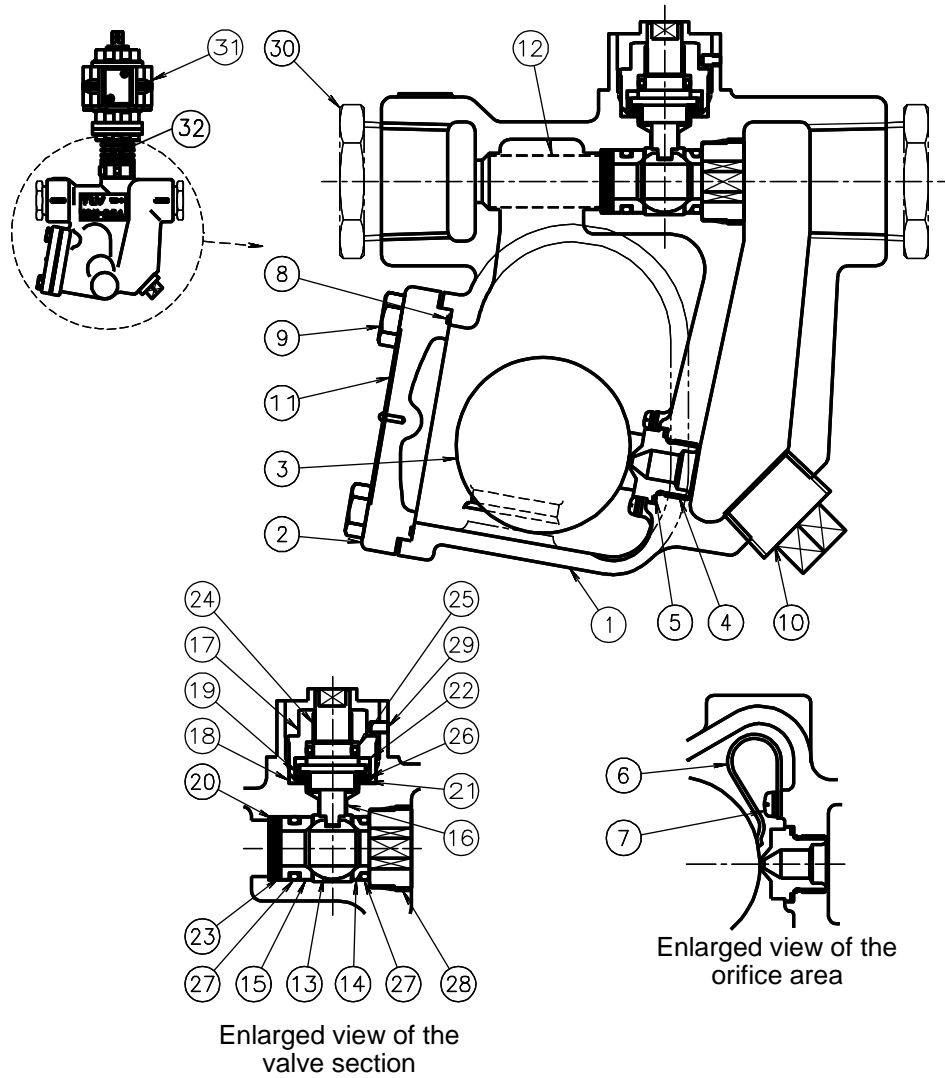

No.	Name	No.	Name	No.	Name
1	Body	13	Ball	25	Seal
2	Cover	14	Outlet Valve Seat	26	Washer
3	Float	15	Inlet Valve Seat	27	O-ring (Inlet/Outlet Valve Seat)
4	Orifice	16	Spindle	28	Valve Holder
5	Orifice Gasket	17	Gland Holder	29	Holder Screw (Gland Holder)
6	Air Vent Strip (Bimetal)	18	Gland Holder Gasket	30	Bushing*
7	Screw & Spring Washer	19	Gland Seat	31	Actuator Unit
8	Cover Gasket	20	Disc Spring	32	Shaft Coupling
9	Cover Bolt	21	Disc Spring		
10	Orifice Plug	22	Gland Packing		
11	Nameplate	23	Washer		
12	Screen	24	Guide Bushing		

* Included only with 15 and 20 mm sizes.

Installation and Operation



Install properly and **DO NOT** use this product outside the recommended operating pressure, temperature and other specification ranges. Improper use may result in such hazards as damage to the product or malfunctions which may lead to serious accidents. Local regulations may restrict the use of this product to below the conditions quoted.



Take measures to prevent people from coming into direct contact with product outlets. Failure to do so may result in burns or other injury from the discharge of fluids.



Do not use excessive force when connecting threaded pipes to the product. Over-tightening may cause breakage leading to fluid discharge, which may cause burns or other injury.



Do not stand on or apply body weight to the handle. The handle may break, resulting in injury or other accidents.

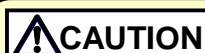

Make sure the power supply switch is OFF before carrying out work on the wiring or inspections involving disassembly. If such work is carried out with the power on, there is a danger that equipment may malfunction or electric shock may occur, leading to injury or other accidents.



Make sure that wiring work requiring a special license is carried out by qualified personnel. If carried out by unqualified personnel, overheating or short circuits leading to injury, fires, damage or other accidents may occur.



When using this product, **NEVER** stand close to, or leave tools anywhere near moving parts, such as the shaft. Contact with moving parts or objects becoming caught in moving parts could lead to injury, damage or other accidents.

Installation, inspection, maintenance, repairs, disassembly, adjustment and valve opening/closing should be carried out only by trained maintenance personnel.

1. Before installation, be sure to remove all protective seals.
2. Before installing the trap, open the inlet valve and thoroughly blow out the piping to remove any piping scraps, dirt and oil. Blowdown is possible after the product has been installed, however it is recommended that you remove all dirt, oil, etc. from the inlet piping before installation. Close the inlet valve after blowdown.
3. Confirm that sufficient maintenance space has been provided around the product.

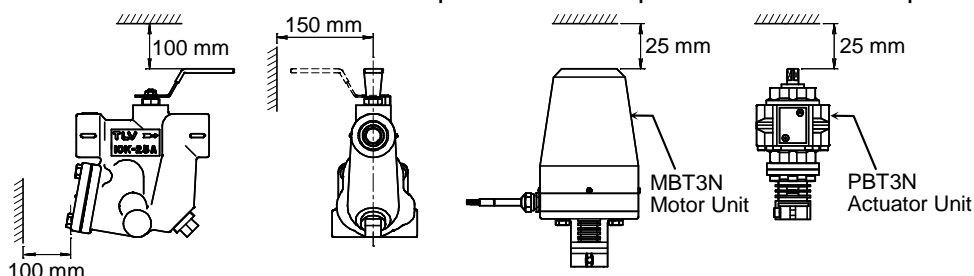

4. Where the product is installed in a location that may be affected by radiant heat from nearby heat-generation, install a device to block the radiant heat, such as a protective plate.
5. 15 mm and 20 mm sizes come with an additional bushing (refer to the "Configuration" section). Be sure to screw the bushing or 25mm diameter piping to the body only up to a point where at least 15 mm remain protruding from the connecting screw. Over-tightening may cause breakage.
6. Install the product so that the arrow on the product is pointing in the direction of

condensate flow.

7. The product should be inclined no more than 5° horizontally and front-to-back.
8. Install the condensate outlet valve and the outlet piping.

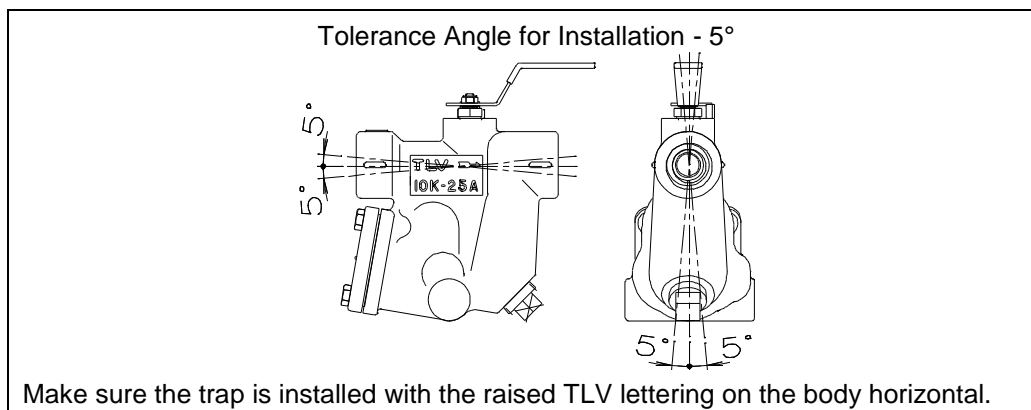

BT3N: Operation

1. Turn the handle to a position perpendicular to the piping.
(The integrated ball valve will close, causing the product to function as a trap.)
Open the inlet and outlet valves slowly and check to make sure that the product functions properly as a steam trap.
If there is a problem, determine the cause by using the "Troubleshooting" section in this manual.
 2. To use the bypass function, turn the handle to a position parallel to the piping.
(The integrated ball valve will open.)
 3. Return the handle to a position perpendicular to the piping to stop using the bypass function.
(The integrated ball valve will close, causing the product to function as a trap.)
 4. The integrated ball valve should be closed when the product is used as a trap.
- NOTE: Operate the bypass valve (ball valve) in only the fully open or fully closed positions. Operation in an intermediate position will damage the valve seat and may lead to leaking of the valve.

MBT3N: Wiring/Operation

1. Connect the ON/OFF control switch as follows:
When the control switch is ON, the valve will open; when it is OFF, the valve will close.
2. If connected to the yellow wire, a pilot lamp will light when the valve is open; if to the brown, a pilot lamp will light when the valve is closed.
3. When checking the operation of the motor unit before installation, keep fingers well clear of the bypass blowdown valve section.

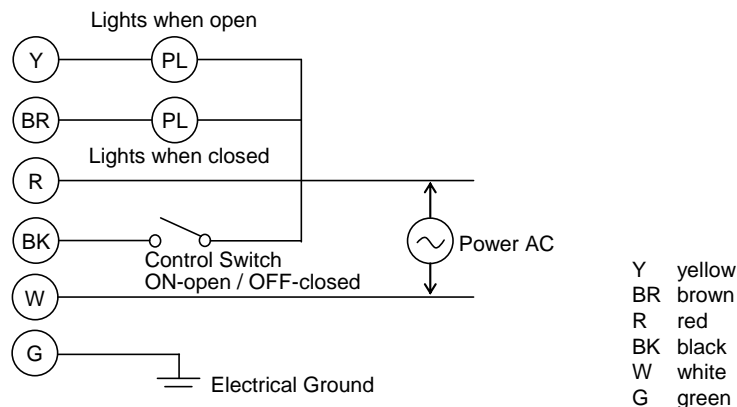

4. Carry out an operational check of the motor under no-load conditions (no pressure) before actual operation to ensure that the wiring is done properly.
You can check whether the valve is opened or closed by checking the orientation of the flat surfaces on the shaft coupling at the base of the motor unit. (See p.15)
When the flat surfaces of the shaft coupling are lined up with the piping, the valve is open; when they are perpendicular, the valve is closed.
5. Make sure the control switch is OFF at start-up.
(The integrated ball valve is closed, causing the product to function as a trap.)
Open the inlet and outlet valves slowly and check to make sure that the product functions properly as a steam trap.
If there is a problem, determine the cause by using the "Troubleshooting" section of this manual.
6. Turn the control switch ON to use the bypass function.
(The integrated ball valve will be open.)
7. Turn the control switch OFF to stop using the bypass function.
(The integrated ball valve will be closed.)
8. The integrated ball valve should be closed when the product is used as a trap.

PBT3N: Air Supply Piping/Operation

1. Use only clean air, which has been run through an air trap, filter, oiler, etc.
2. Make sure there is no foreign matter, particularly dirt or sealing tape, in the pneumatic actuator.
3. The table below shows the relationship between the air supply and valve opening/closing.

Port: A	Port: B	Valve
Supply	Exhaust	Open
Exhaust	Supply	Closed

4. When checking operation of the pneumatic actuator before installation, keep fingers well clear of the bypass blowdown valve section.

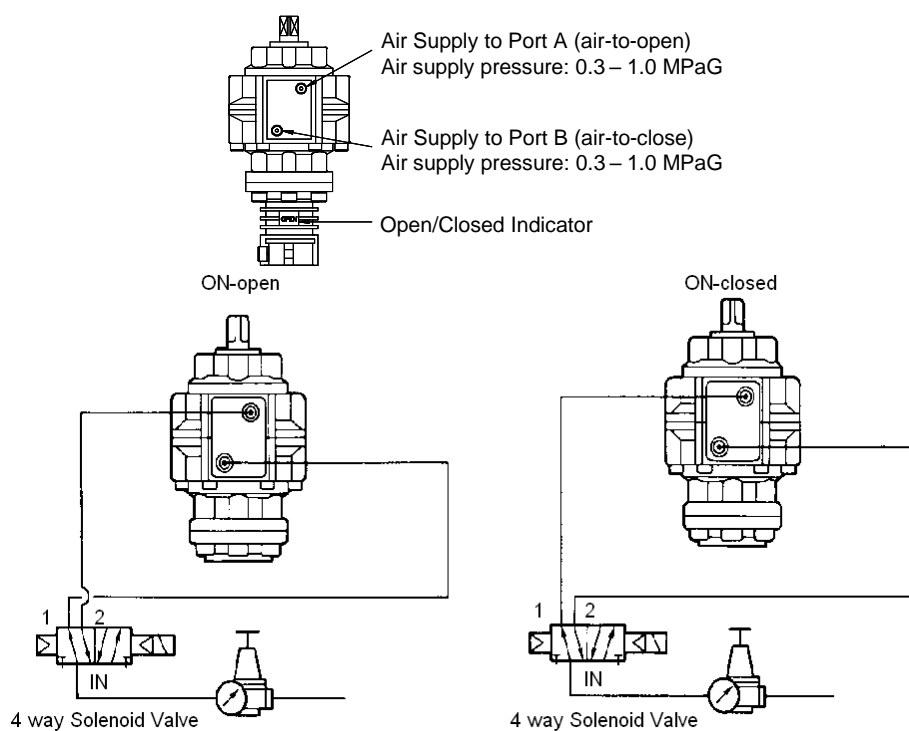

5. Carry out an operational check of the actuator under no-load conditions (no pressure) before actual operation to ensure that the air is supplied properly. The “Open/Closed” Indicator located in the lower part of the actuator indicates whether the valve is opened/closed.
6. Make sure that the integrated ball valve is closed at start-up, causing the product to function as a trap. The state of the integrated ball valve can be confirmed using the “open/closed” indicator. Open the inlet and outlet valves slowly and check to make sure that the product functions properly. If there is a problem, determine the cause by using the “Troubleshooting” section in this manual.
7. To use the bypass function, supply air through port A and exhaust the air in the actuator through port B. The integrated ball valve will open.
8. To stop using the bypass function, supply air through port B and exhaust the air in the actuator through port A. Integrated ball valve will close.
9. The integrated ball valve should be closed when the product is used as a trap.

Manual Operation



Take measures to prevent people from coming into direct contact with product outlets. Failure to do so may result in burns or other injury from the discharge of fluids.

MBT3N

1. Perform manual operation only after making sure that the power is OFF. Manual operation cannot be performed when the power is ON. For safety, make sure the power is OFF even during a power outage.
2. Grasp the flat surfaces of the shaft coupling at the base of the motor unit with a wrench, and turn in the direction of the arrows. When the flat surfaces of the shaft coupling are lined up with the piping, the valve is open; when they are perpendicular, the valve is closed (distance across flats: 19 mm).

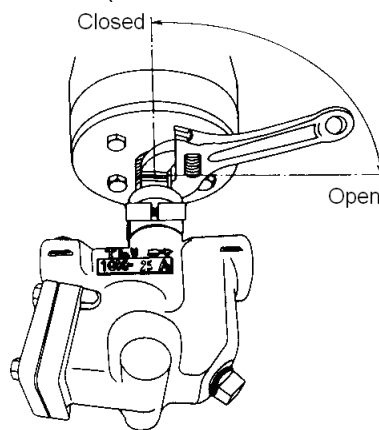

PBT3N

1. Perform manual operation only after shutting off the air supply first and making sure there is no pressure remaining inside the actuator unit. Manual operation can not be performed if there is pressure remaining inside the actuator unit.
2. Grasp the manual operation key on the top of the actuator unit with a wrench, and turn in the direction of the arrows (distance across flats: 10 mm).

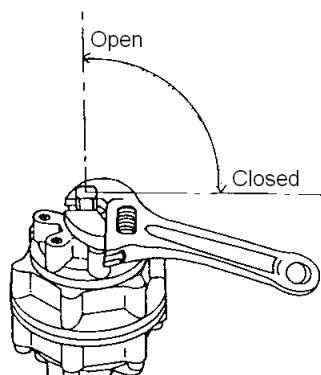

Maintenance



Take measures to prevent people from coming into direct contact with product outlets. Failure to do so may result in burns or other injury from the discharge of fluids.



Be sure to use only the recommended components when repairing the product, and NEVER attempt to modify the product in any way. Failure to observe these precautions may result in damage to the product or burns or other injury due to malfunction or the discharge of fluids.

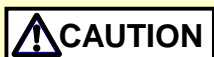

When using this product, NEVER stand close to, or leave tools anywhere near moving parts, such as the shaft. Contact with moving parts or objects becoming caught in moving parts could lead to injury, damage or other accidents.

BT3N/MBT3N/PBT3N: Operational Check of the Steam Trap

The following inspections should be carried out only after making sure that the bypass valve is closed: A visual inspection of the following items should be done on a daily basis to determine whether the trap is operating properly or has failed. Periodically (at least biannually) the operation should also be checked by using diagnostic equipment, such as a stethoscope or thermometer. (Inspection, installation, maintenance, repairs, disassembly, adjustment and valve opening/closing should be carried out only by trained maintenance personnel.)

To determine whether the bypass valve is closed, make sure that the flat surfaces of the spindle (BT3N) or the shaft coupling (MBT3N and PBT3N) are perpendicular to the piping.

If the valve is not fully closed when the flat surfaces are in this position, there is a problem. Refer to the "Troubleshooting" section to determine the cause, then correct the problem.

If the trap or bypass blowdown valve should fail, it may cause damage to piping and equipment, resulting in faulty or low quality products or losses due to steam leakage.

- | | | |
|--------------------------------------|---|---|
| Normal | : | Condensate, together with flash steam, is discharged continuously, accompanied by the powerful rushing sound of flow. When the amount of condensate being discharged is very slight, the sound of flow is almost inaudible. |
| Blocked
(Discharge
Impossible) | : | No condensate is discharged. The trap is quiet and makes no noise, and the surface temperature of the trap is low. |
| Blowing | : | Live steam continuously flows from the outlet and there is a continuous piercing metallic sound. |
| Steam Leakage | : | Live steam is discharged through the outlet together with the condensate and there is a high-pitched hissing sound. |

(When conducting a visual inspection, flash steam is sometimes mistaken for steam leakage. For this reason, the use of a steam trap diagnostic instrument - such as TLV TrapMan - in conjunction with the visual inspection is highly recommended.)

MBT3N: Operational Check of the Motor Unit and Bypass Valve Section

1. An operational check shall be performed at least once every 6 months.
2. Turn the motor unit power ON and check the operation of the motor unit (angle of rotation, time required to open/close the valve, sound).
3. After turning the motor unit power OFF, manually operate the valve, check for foreign matter in the valve and confirm torques.

Refer to the following table for tightening torques. A torque of more than 2 times the shown torque is considered abnormal, and an inspection should be performed.

Tightening Torque N·m		
No load	0.5 MPaG load	1.0 MPaG load
0.4	0.5	0.6

(1 N·m \approx 10 kg·cm)

(1 MPa = 10.197 kg/cm²)

PBT3N: Operational Check of the Actuator Unit and Bypass Valve Section

1. An operational check shall be performed at least once every 6 months.
2. Making sure there is air supplied to the actuator, check the operation (angle of rotation, time required to open/close the valve, sound).
3. After shutting off the air supply, manually operate the valve, check for foreign matter in the valve and confirm torques.

Refer to the following table for tightening torques. A torque of more than 2 times the shown torque is considered abnormal, and an inspection should be performed.

Tightening Torque N·m		
No load	0.5 MPaG load	1.0 MPaG load
0.4	0.5	0.6

(1 N·m \approx 10 kg·cm)

(1 MPa = 10.197 kg/cm²)

BT3N: Additional Tightening of the Valve Unit Gland Section

It is possible to further tighten the gland section in the BT3N valve unit.

Holding the handle tightly, by hand, so that it cannot rotate, use a wrench to tighten the locknut at the top of the handle (distance across flats: 10 mm).

Cautions when applying additional tightening:

- Do not tighten the locknut completely the first time. Do not tighten it any more than is necessary to stop leakage.
- If leakage continues even after applying additional tightening to the locknut, replace parts (part No. 16, spindle; part No. 18, gland gasket; part No. 22, gland packing; part No. 28, locknut).

MBT3N/PBT3N: Additional Tightening of the Valve Unit Gland Section

It is possible to further tighten the gland section in the MBT3N/PBT3N valve units.

1. Detach the actuator unit (refer to the “Disassembly/Reassembly” section for details).
2. Follow the steps given below to apply additional tightening
 - 1) Loosen the holder screw.
 - 2) Tighten the gland holder further in with a socket wrench.

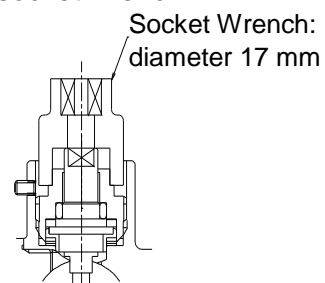
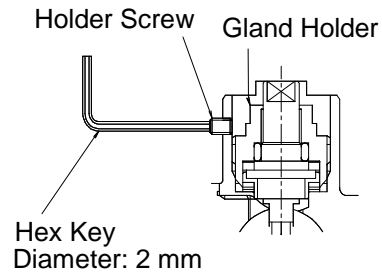

- 3) Retighten the holder screw.

Cautions when applying additional tightening:

- Do not tighten the gland holder completely the first time. Do not tighten it any more than necessary to stop leakage.
- If leakage continues even after applying additional tightening to the gland holder, replace parts.

Disassembly / Reassembly



NEVER apply direct heat to the float. The float may explode due to increased internal pressure, causing accidents leading to serious injury or damage to property and equipment.



When disassembling or removing the product, wait until the internal pressure equals atmospheric pressure and the surface of the product has cooled to room temperature. Disassembling or removing the product when it is hot or under pressure may lead to discharge of fluids, causing burns, other injuries or damage.



Do not use excessive force when connecting threaded pipes to the product. Over-tightening may cause breakage leading to fluid discharge, which may cause burns or other injury.



Be sure to use only the recommended components when repairing the product, and **NEVER** attempt to modify the product in any way. Failure to observe these precautions may result in damage to the product or burns or other injury due to malfunction or the discharge of fluids.

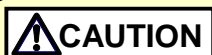

Make sure the power supply is **OFF** before carrying out work on the wiring or inspections involving disassembly. If such work is carried out with the power on, there is a danger that equipment may malfunction or electric shock may occur, leading to injury or other accidents.

Use the following procedures to remove components. Use the same procedures in reverse to reassemble.

(Installation, inspection, maintenance, repairs, disassembly, adjustment and valve opening/closing should be carried out only by trained maintenance personnel.)

BT3N/MBT3N/PBT3N: Disassembly/Reassembly of the Steam Trap

Part	During Disassembly	During Reassembly	During Inspection
Orifice Plug	Remove with a wrench: dist. across flats - 17 mm	Wrap 3-3.5 turns of sealing tape around threads and tighten to the proper torque: torque - 70 N·m dist. across flats - 17 mm	—
Cover Bolt	Remove with a wrench: dist. across flats - 13 mm	Coat threads with anti-seize and tighten to the proper torque: torque - 40 N·m dist. across flats - 13 mm	—
Cover	Remove the cover	Replace the cover	—
Cover Gasket	Remove the cover gasket	Replace with a new cover gasket only if misshapen or damaged	—
Float	Remove the float	Reinsert the float gently	Check for deformation or scratches
Screw & Spring Washer	Remove the screw & the spring washer	Coat threads with anti-seize and tighten to the proper torque: torque - 1.5 N·m	—
Air Vent Strip	Remove the air vent strip	Be careful not to deform the strip	Check the tip for splitting, corrosion, etc.
Orifice	Remove with a socket wrench: dist. across flats - 17 mm	Coat threads with anti-seize and tighten to the proper torque: torque - 40 N·m dist. across flats - 17 mm	Check the sealing surfaces for scratches, wear, etc.
Orifice Gasket	Remove the orifice gasket	Replace with a new orifice gasket only if misshapen or damaged	—

Refer to the sketch shown on the next page.

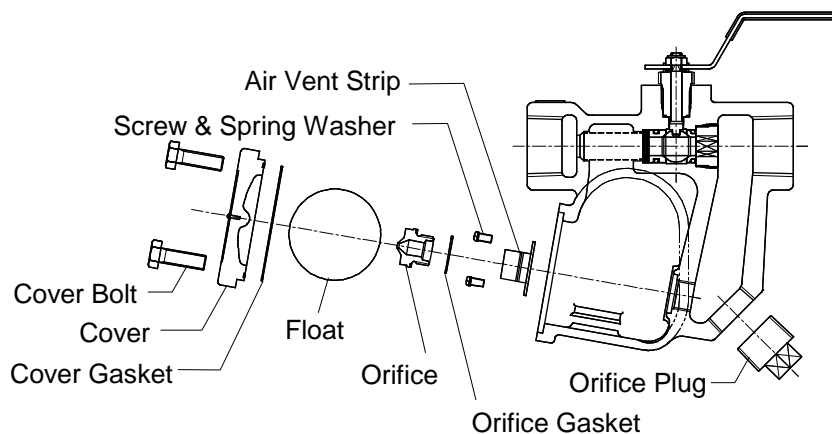

MBT3N/PBT3N: Detaching/Reattaching the Motor Unit or Actuator Unit

Part	During Disassembly	During Reassembly	During Inspection
Screw & Spring Washer	Remove the screw & the spring washer	Coat threads with anti-seize and tighten to the proper torque: torque - 0.8 N·m	—
Hex Key Bolt	Remove with a hex key: dist. across flats - 5 mm	Coat threads with anti-seize and tighten to the proper torque: torque - 10 N·m dist. across flats - 5 mm	—
Spring Washer	Remove the spring washer	Reinsert the spring washer	—
Motor or Actuator Unit	Detach the motor or the actuator unit	Reattach the motor or the actuator unit	—
Shaft Coupling	Detach the shaft coupling	Reattach the shaft coupling	Check for deformation or wear

(1 N·m ≈ 10 kg·cm)

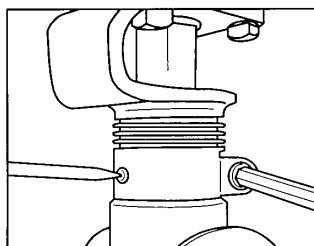

BT3N: Disassembly/Reassembly of the Bypass Valve Gland Section

Part	During Disassembly	During Reassembly	During Inspection
Locknut	Remove with a wrench: dist. across flats - 10 mm	A new locknut must be used Tighten to the proper torque: torque - 2.5 N·m (Guideline for new nut) dist. across flats - 10 mm	—
Handle	Pull the handle up off of the spindle	Reattach the handle, being careful of its orientation (see the drawing below)	Check the handle hole in the spindle for deformation
Disc Spring	Remove the disc spring	Reinsert the disc spring, referring to the drawing below for proper operation	Check for damage or deformation
Thrust Washer	Remove the thrust washer	Reinsert the thrust washer	Check for wear
Gland	Remove with a wrench: dist. across flats - 17 mm	Coat threads with anti-seize, then tighten to the proper torque: torque - 35 N·m dist. across flats - 17 mm	Check the spindle sleeve area for signs of seizure, deformation, scratches, etc.
Spindle	Remove the spindle	Replace with a new spindle, coat sliding area with gland and threads with anti-seize	—
Gland Gasket	Remove the gland gasket	Replace with a new gland gasket only if warped or damaged	—
Gland Packing	Remove the gland packing	Replace with a new gland packing	—

(1 N·m ≈ 10 kg·cm)

- NOTE: 1. Reassemble the gland section after reassembling the valve section.
 2. Finger-tightening the valve holder first makes it easier to reinsert the spindle into the ball. After reinserting the spindle, tighten the valve holder and the gland.
 3. **Removing the handle and the locknut from the BT3N destroys the gland section seal. Do not detach the handle and the locknut unless performing a disassembly inspection.**

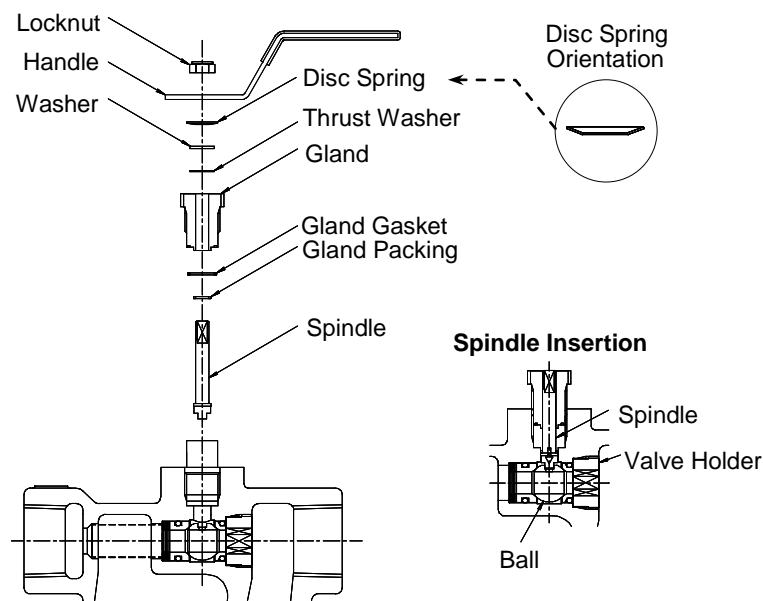

MBT3N/PBT3N: Disassembly/Reassembly of the Bypass Valve Gland Section

Part	During Disassembly	During Reassembly	During Inspection
Holder Screw (Gland Holder)	Remove with a hex key: dist. across flats - 2 mm	Coat threads with anti-seize, then tighten to the proper torque: torque - 1.0 N·m dist. across flats - 2 mm	—
Gland Holder	Remove with a socket wrench: dist. across flats - 17 mm	Tighten to the proper torque: torque - 1.0 N·m dist. across flats - 17 mm	—
Guide Bushing	Remove the guide bushing	Reinsert the guide bushing	Check for wear
Seal	Remove the seal	Replace with a new seal	—
Gland Packing	Remove the gland packing	Replace with a new gland packing	—
Spindle	Remove the spindle	Reinsert the spindle	Check flat surfaces for deformation, wear, scratches, corrosion, etc.
Gland Seat	Remove the gland seat	Replace with a new gland seat	—
Washer	Remove the washer	Reinsert the washer	Check for damage deformation, etc.
Disc Spring	Remove the disc springs	Reinsert with the proper orientation (see the fig. below)	Check for damage, deformation, etc.
Gland Holder Gasket	Remove the gland holder gasket	Replace with a new gland holder gasket only if misshapen or damaged, being careful of the orientation	—

(1 N·m ≈ 10 kg·cm)

- NOTE: 1. Reassemble the gland section after reassembling the valve section.
 2. Finger-tightening the valve holder first makes it easier to reinsert the spindle into the ball. After reinserting the spindle, tighten the valve holder.

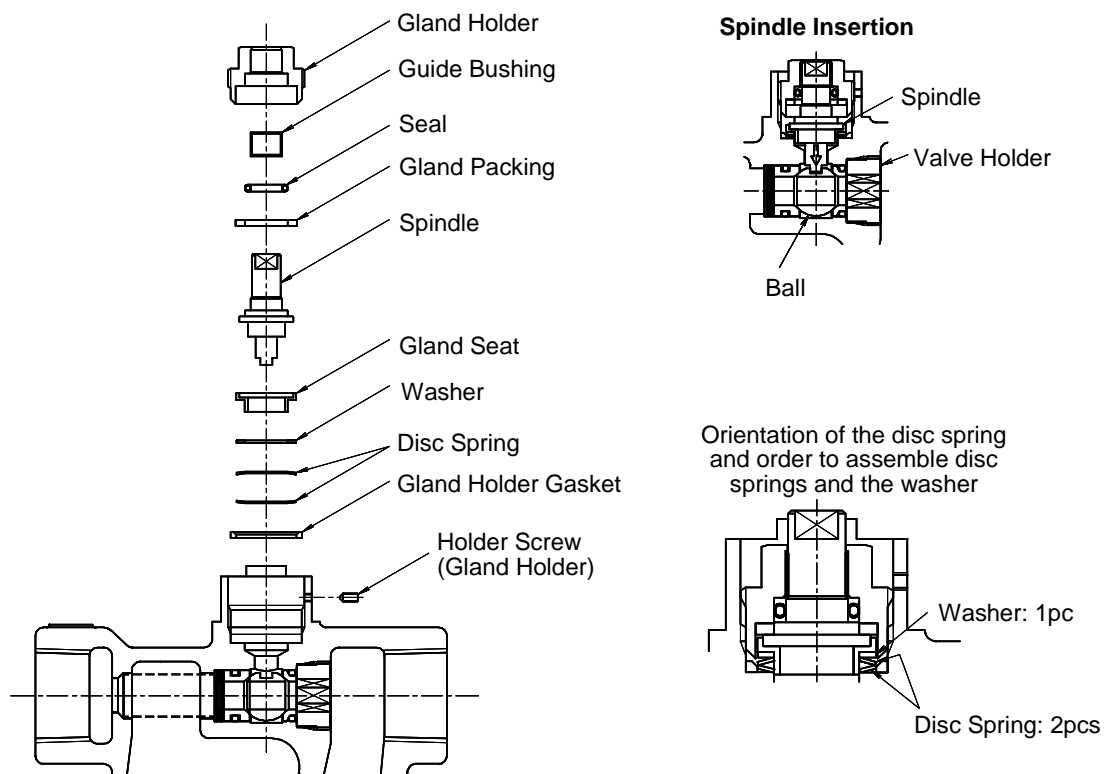

BT3N/MBT3N/PBT3N: Disassembly/Reassembly of Bypass Valve Section

Part	During Disassembly	During Reassembly	During Inspection
Bushing (only sizes for 15 & 20 mm)	Remove with a wrench: dist. across flats - 38 mm	Wrap 3-3.5 turns of sealing tape around threads and tighten to the proper torque: torque - 100 N·m dist. across flats - 38 mm	—
Valve Holder	Remove with a hex key: dist. across flats - 10 mm	Coat threads with anti-seize, then tighten to the proper torque: torque - 40 N·m dist. across flats - 10 mm	—
O-ring (Outlet Valve Seat)	Remove the o-ring	Replace with a new o-ring, insert into the outlet valve seat	—
Outlet Valve Seat	Remove the outlet valve seat	Replace with a new outlet valve seat	—
Ball	Remove the ball	Reinsert the ball	Check sealing surfaces for scratches, wear, etc.
Inlet Valve Seat	Remove the inlet valve seat	Replace with a new inlet valve seat	—
O-ring (Inlet Valve Seat)	Remove the o-ring	Replace with a new o-ring, insert into the inlet valve seat	—
Washer	Remove the washer	Reinsert the washer	Check for damage, deformation, etc.
Disc Spring	Remove the disc spring	Reinsert with the proper orientation (refer to the fig. below)	Check for damage, deformation, etc.
Washer	Remove the washer	Reinsert the washer	Check for damage, deformation, etc.
Disc Spring	Remove the disc spring	Reinsert with the proper orientation (refer to the fig. below)	Check for damage, deformation, etc.
Washer	Remove the washer	Reinsert the washer	Check for damage, deformation, etc.
Screen	Remove the screen	Reinsert the screen	Check for clogging, corrosion, damage, etc.

(1 N·m ≈ 10 kg·cm)

NOTE: Clean, then check the inside of the body for scratches and erosion.

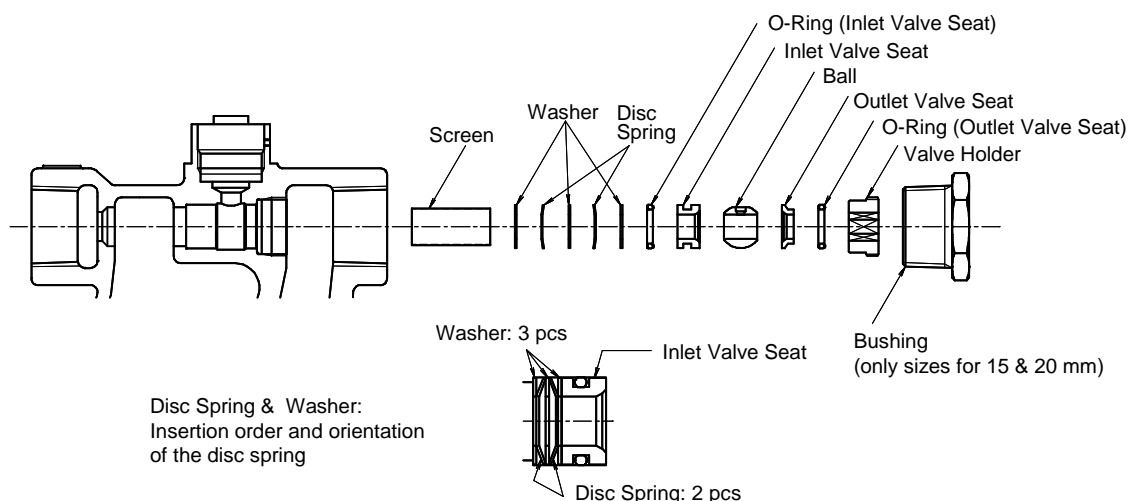

Troubleshooting



WARNING

NEVER apply direct heat to the float. The float may explode due to increased internal pressure, causing accidents leading to serious injury or damage to property and equipment.



CAUTION

When disassembling or removing the product, wait until the internal pressure equals atmospheric pressure and the surface of the product has cooled to room temperature. Disassembling or removing the product when it is hot or under pressure may lead to discharge of fluids, causing burns, other injuries or damage.

When the trap fails to operate properly, use the following table to locate and remedy the cause.

BT3N/MBT3N/PBT3N: Troubleshooting for the Steam Trap and Bypass Valve

Problem	Diagnosis (Cause)	Remedy
No condensate is discharged (blocked) or discharge is poor	Check to see if the float is damaged or filled with condensate	Replace with a new float
	Check the orifice, screen and the piping to see if they are clogged with rust and scale	Clean parts
	Check to see if the trap operating pressure exceeds the maximum specified pressure, or whether there is insufficient pressure differential between the trap inlet and outlet	Compare specifications and actual operating conditions
	Check to see if steam-locking has occurred	Perform a bypass blowdown
Steam is discharged or leaks from the outlet (blowing) (steam leakage)	Check for a clogged orifice or rust and scale under the float	Clean parts
	Check for damage to the orifice	Replace with a new orifice
	Check that the float is not misshapen or coated with scale	Clean or replace with a new float
	Check for the improper installation	Correct the installation
	Check for trap vibration	Lengthen the inlet piping and fasten it securely
	Check to see if the bypass valve is open	Close the bypass valve
Steam leaks from the bypass valve gland	Check the valve sealing surfaces for dirt or scratches, and the o-ring (outlet valve seat) for scratches or damage	Clean or replace parts
	Check for dirt, scratches or wear on the gland packing	Clean or replace parts
The bypass valve does not move or remains half-open	Check to see if the valve seat or the ball have build-up (the ball should turn easily: normal operation torque is less than 1.0 N·m)	Clean parts
	Check the shaft coupling for wear or deformation	Replace with a new shaft coupling
	Check the motor unit or actuator unit (see following pages)	Replace with a new motor unit or an actuator unit
Steam is leaking from a place other than the outlet	Check for the gasket deterioration or damage	Replace with new gasket(s)
	Check to make sure that the proper tightening torques are used	Tighten to the proper torque
Float frequently becomes damaged	Check to see if water hammer has occurred	Study and correct the piping

MBT3N: Troubleshooting for the Motor Unit

When the motor unit fails to operate as it did when first installed, use the following table to locate and remedy the cause. Detach the motor unit from the trap body when checking the motor unit itself. (For detaching the actuator unit from the trap body, refer to the “Disassembly / Reassembly” section.)

Problem	Diagnosis (Cause)	Remedy
Does not operate even though the control switch is ON	Turn OFF the power, and check to see if manual operation is possible	The motor unit is broken; contact TLV
	Check for improper wiring or control	Correct the problem
	Check to make sure that the main power is ON, and that the voltage is correct, also check current and fuses	Correct problem
	Check whether the thermo-protector is in operation or not	After allowing the motor unit to cool down, check its operation again to ascertain whether the thermo-protector is the cause
Reciprocating action is repeated over and over	Check to see if there is a problem with the control system	Correct the problem
Rotation only takes place in one direction	Check to see if there is a problem with the control system	Correct the problem
Does not rotate the full 90°, stops at a partial rotation	Check to see if there is a problem with the control system	Correct the problem

If after attempting all of the above remedies the product still does not operate properly, contact TLV after confirming operating pressure, operating temperature, operating frequency and serial number.

All motor units must be repaired by TLV. DO NOT disassemble the motor unit yourself.

PBT3N: Troubleshooting for the Actuator Unit

When the actuator unit fails to operate as it did when first installed, use the following table to locate and remedy the cause. Detach the actuator unit from the trap body when checking the actuator unit itself. (For detaching the actuator unit from the trap body, refer to the “Disassembly/Reassembly” section.)

Problem	Diagnosis (Cause)	Remedy
Does not operate even though the control switch is ON	Shut off the air supply, make sure there is no pressure left in the actuator unit, then check to see if manual operation is possible	The actuator unit is broken; contact TLV
	Check for a problem with the solenoid valve	Replace with a new solenoid valve
	Check to make sure that the power is reaching the solenoid valve and that the voltage is correct, also check current and fuses	Correct the problem
	Check for proper air supply	Correct irregularities
	Check to see if the filter and the air supply ports are clogged	Clean parts

Troubleshooting continued on next page

Problem	Diagnosis (Cause)	Remedy
Reciprocating action is repeated over and over	Check to see if there is a problem with the magnetic control system	Correct the problem
Rotation only takes place in one direction	Check to see if there is a problem with the magnetic control system	Correct the problem
	Check to see if the filter and the air supply ports are clogged	Clean parts
Does not rotate the full 90°, stops at a partial rotation	Check to see if there is a problem with the air supply	Correct the problem
	Check to see if the filter and the air supply ports are clogged	Clean parts

If after attempting all of the above remedies the product still does not operate properly, contact TLV after confirming operating pressure, operating temperature, operating frequency and serial number.

All actuator units must be repaired by TLV. DO NOT disassemble the actuator unit yourself.

TLV EXPRESS LIMITED WARRANTY

Subject to the limitations set forth below, TLV CO., LTD., a Japanese corporation (“**TLV**”), warrants that products which are sold by it, TLV International Inc. (“**TII**”) or one of its group companies excluding TLV Corporation (a corporation of the United States of America), (hereinafter the “**Products**”) are designed and manufactured by TLV, conform to the specifications published by TLV for the corresponding part numbers (the “**Specifications**”) and are free from defective workmanship and materials. The party from whom the Products were purchased shall be known hereinafter as the “**Seller**”. With regard to products or components manufactured by unrelated third parties (the “**Components**”), TLV provides no warranty other than the warranty from the third party manufacturer(s), if any.

Exceptions to Warranty

This warranty does not cover defects or failures caused by:

1. improper shipping, installation, use, handling, etc., by persons other than TLV, TII or TLV group company personnel, or service representatives authorized by TLV; or
2. dirt, scale or rust, etc.; or
3. improper disassembly and reassembly, or inadequate inspection and maintenance by persons other than TLV or TLV group company personnel, or service representatives authorized by TLV; or
4. disasters or forces of nature or Acts of God; or
5. abuse, abnormal use, accidents or any other cause beyond the control of TLV, TII or TLV group companies; or
6. improper storage, maintenance or repair; or
7. operation of the Products not in accordance with instructions issued with the Products or with accepted industry practices; or
8. use for a purpose or in a manner for which the Products were not intended; or
9. use of the Products in a manner inconsistent with the Specifications; or
10. use of the Products with Hazardous Fluids (fluids other than steam, air, water, nitrogen, carbon dioxide and inert gases (helium, neon, argon, krypton, xenon and radon)); or
11. failure to follow the instructions contained in the TLV Instruction Manual for the Product.

Duration of Warranty

This warranty is effective for a period of one (1) year after delivery of Products to the first end user. Notwithstanding the foregoing, asserting a claim under this warranty must be brought within three (3) years after the date of delivery to the initial buyer if not sold initially to the first end user.

ANY IMPLIED WARRANTIES NOT NEGATED HEREBY WHICH MAY ARISE BY OPERATION OF LAW, INCLUDING THE IMPLIED WARRANTIES OF MERCHANTABILITY AND FITNESS FOR A PARTICULAR PURPOSE AND ANY EXPRESS WARRANTIES NOT NEGATED HEREBY, ARE GIVEN SOLELY TO THE INITIAL BUYER AND ARE LIMITED IN DURATION TO ONE (1) YEAR FROM THE DATE OF SHIPMENT BY THE SELLER.

Exclusive Remedy

THE EXCLUSIVE REMEDY UNDER THIS WARRANTY, UNDER ANY EXPRESS WARRANTY OR UNDER ANY IMPLIED WARRANTIES NOT NEGATED HEREBY (INCLUDING THE IMPLIED WARRANTIES OF MERCHANTABILITY AND FITNESS FOR A PARTICULAR PURPOSE), IS **REPLACEMENT**; PROVIDED: (a) THE CLAIMED DEFECT IS REPORTED TO THE SELLER IN WRITING WITHIN THE WARRANTY PERIOD, INCLUDING A DETAILED WRITTEN DESCRIPTION OF THE CLAIMED DEFECT AND HOW AND WHEN THE CLAIMED DEFECTIVE PRODUCT WAS USED; AND (b) THE CLAIMED DEFECTIVE PRODUCT AND A COPY OF THE PURCHASE INVOICE IS RETURNED TO THE SELLER, FREIGHT AND

TRANSPORTATION COSTS PREPAID, UNDER A RETURN MATERIAL AUTHORIZATION AND TRACKING NUMBER ISSUED BY THE SELLER. ALL LABOR COSTS, SHIPPING COSTS, AND TRANSPORTATION COSTS ASSOCIATED WITH THE RETURN OR REPLACEMENT OF THE CLAIMED DEFECTIVE PRODUCT ARE SOLELY THE RESPONSIBILITY OF BUYER OR THE FIRST END USER. THE SELLER RESERVES THE RIGHT TO INSPECT ON THE FIRST END USER'S SITE ANY PRODUCTS CLAIMED TO BE DEFECTIVE BEFORE ISSUING A RETURN MATERIAL AUTHORIZATION. SHOULD SUCH INSPECTION REVEAL, IN THE SELLER'S REASONABLE DISCRETION, THAT THE CLAIMED DEFECT IS NOT COVERED BY THIS WARRANTY, THE PARTY ASSERTING THIS WARRANTY SHALL PAY THE SELLER FOR THE TIME AND EXPENSES RELATED TO SUCH ON-SITE INSPECTION.

Exclusion of Consequential and Incidental Damages

IT IS SPECIFICALLY ACKNOWLEDGED THAT THIS WARRANTY, ANY OTHER EXPRESS WARRANTY NOT NEGATED HEREBY, AND ANY IMPLIED WARRANTY NOT NEGATED HEREBY, INCLUDING THE IMPLIED WARRANTIES OF MERCHANTABILITY AND FITNESS FOR A PARTICULAR PURPOSE, DO NOT COVER, AND NEITHER TLV, TII NOR ITS TLV GROUP COMPANIES WILL IN ANY EVENT BE LIABLE FOR, INCIDENTAL OR CONSEQUENTIAL DAMAGES, INCLUDING, BUT NOT LIMITED TO LOST PROFITS, THE COST OF DISASSEMBLY AND SHIPMENT OF THE DEFECTIVE PRODUCT, INJURY TO OTHER PROPERTY, DAMAGE TO BUYER'S OR THE FIRST END USER'S PRODUCT, DAMAGE TO BUYER'S OR THE FIRST END USER'S PROCESSES, LOSS OF USE, OR OTHER COMMERCIAL LOSSES. WHERE, DUE TO OPERATION OF LAW, CONSEQUENTIAL AND INCIDENTAL DAMAGES UNDER THIS WARRANTY, UNDER ANY OTHER EXPRESS WARRANTY NOT NEGATED HEREBY OR UNDER ANY IMPLIED WARRANTY NOT NEGATED HEREBY (INCLUDING THE IMPLIED WARRANTIES OF MERCHANTABILITY AND FITNESS FOR A PARTICULAR PURPOSE) CANNOT BE EXCLUDED, SUCH DAMAGES ARE EXPRESSLY LIMITED IN AMOUNT TO THE PURCHASE PRICE OF THE DEFECTIVE PRODUCT. THIS EXCLUSION OF CONSEQUENTIAL AND INCIDENTAL DAMAGES, AND THE PROVISION OF THIS WARRANTY LIMITING REMEDIES HEREUNDER TO REPLACEMENT, ARE INDEPENDENT PROVISIONS, AND ANY DETERMINATION THAT THE LIMITATION OF REMEDIES FAILS OF ITS ESSENTIAL PURPOSE OR ANY OTHER DETERMINATION THAT EITHER OF THE ABOVE REMEDIES IS UNENFORCEABLE, SHALL NOT BE CONSTRUED TO MAKE THE OTHER PROVISIONS UNENFORCEABLE.

Exclusion of Other Warranties

THIS WARRANTY IS IN LIEU OF ALL OTHER WARRANTIES, EXPRESS OR IMPLIED, AND ALL OTHER WARRANTIES, INCLUDING BUT NOT LIMITED TO THE IMPLIED WARRANTIES OF MERCHANTABILITY AND FITNESS FOR A PARTICULAR PURPOSE, ARE EXPRESSLY DISCLAIMED.

Severability

Any provision of this warranty which is invalid, prohibited or unenforceable in any jurisdiction shall, as to such jurisdiction, be ineffective to the extent of such invalidity, prohibition or unenforceability without invalidating the remaining provisions hereof, and any such invalidity, prohibition or unenforceability in any such jurisdiction shall not invalidate or render unenforceable such provision in any other jurisdiction.

Service

For Service or Technical Assistance: Contact your TLV representative or your regional TLV office.

In Europe:

TLV EURO ENGINEERING GmbH

Daimler-Benz-Straße 16-18, 74915 Waibstadt, **Germany**

Tel: [49]-(0)7263-9150-0
Fax: [49]-(0)7263-9150-50

TLV EURO ENGINEERING UK LTD.

Units 7 & 8, Furlong Business Park, Bishops Cleeve, Gloucestershire GL52 8TW, **U.K.**

Tel: [44]-(0)1242-227223
Fax: [44]-(0)1242-223077

TLV EURO ENGINEERING FRANCE SARL

Parc d'Ariane 2, bât. C, 290 rue Ferdinand Perrier, 69800 Saint Priest, **France**

Tel: [33]-(0)4-72482222
Fax: [33]-(0)4-72482220

In North America:

TLV CORPORATION

13901 South Lakes Drive, Charlotte, NC 28273-6790, **U.S.A.**

Tel: [1]-704-597-9070
Fax: [1]-704-583-1610

In Mexico and Latin America:

TLV ENGINEERING S. A. DE C.V.

Av. Jesús del Monte 39-B-1001, Col. Hda. de las Palmas, Huixquilucan, Edo. de México, 52763, **Mexico**

Tel: [52]-55-5359-7949
Fax: [52]-55-5359-7585

In Oceania:

TLV PTY LIMITED

Unit 8, 137-145 Rooks Road, Nunawading, Victoria 3131, **Australia**

Tel: [61]-(0)3-9873 5610
Fax: [61]-(0)3-9873 5010

In East Asia:

TLV PTE LTD

36 Kaki Bukit Place, #02-01/02, **Singapore** 416214

Tel: [65]-6747 4600
Fax: [65]-6742 0345

TLV SHANGHAI CO., LTD.

Room 5406, No. 103 Cao Bao Road, Shanghai, **China** 200233

Tel: [86]-(0)21-6482-8622
Fax: [86]-(0)21-6482-8623

TLV ENGINEERING SDN. BHD.

No.16, Jalan MJ14, Taman Industri Meranti Jaya, 47120 Puchong, Selangor, **Malaysia**

Tel: [60]-3-8065-2928
Fax: [60]-3-8065-2923

TLV PRIVATE LIMITED

252/94 (K-L) 17th Floor, Muang Thai-Phatra Complex Tower B, Rachadaphisek Road, Huaykwang, Bangkok 10310, **Thailand**

Tel: [66]-2-693-3799
Fax: [66]-2-693-3979

TLV INC.

#302-1 Bundang Technopark B, 723 Pangyo-ro, Bundang, Seongnam, Gyeonggi, 13511, **Korea**

Tel: [82]-(0)31-726-2105
Fax: [82]-(0)31-726-2195

In the Middle East:

TLV ENGINEERING FZCO

Building 2W, No. M002, PO Box 371684, Dubai Airport Free Zone, Dubai, **UAE**

Email: sales-me@tlv.co.jp

In Other Countries:

TLV INTERNATIONAL, INC.

881 Nagasuna, Noguchi, Kakogawa, Hyogo 675-8511, **Japan**

Tel: [81]-(0)79-427-1818
Fax: [81]-(0)79-425-1167

Manufacturer:

TLV CO., LTD.

881 Nagasuna, Noguchi, Kakogawa, Hyogo 675-8511, **Japan**

Tel: [81]-(0)79-422-1122
Fax: [81]-(0)79-422-0112