



Manufacturer

TLV. CO., LTD.
Kakogawa, Japan

is approved by LRQA LTD. to ISO 9001/14001



Instruction Manual

Cyclone Separator Trap for Air **DC5A**

Contents

Introduction	1
Safety Considerations	2
Specifications	4
Configuration	5
Installation	6
Maintenance	7
Disassembly / Reassembly	8
Troubleshooting	10
Product Warranty	11

Introduction

Thank you for purchasing the **TLV** Cyclone Separator Trap for Air.

This product has been thoroughly inspected before being shipped from the factory. When the separator trap is delivered, before doing anything else, check the specifications and external appearance to make sure nothing is out of the ordinary. Also be sure to read this manual carefully before use and follow the instructions to be sure of using the separator trap properly.

For use on air mains and branches, the Cyclone Separator Traps use centrifugal force to separate condensate from air and other gases, and feature a built-in free float air trap for the automatic discharge of the collected condensate.





If detailed instructions for special order specifications or options not contained in this manual are required, please contact **TLV** for full details.



This instruction manual is for the models listed on the front cover. It is needed not only for installation but for subsequent maintenance, disassembly/reassembly and troubleshooting. Please keep it in a safe place for future reference.

Safety Considerations

- Read this section carefully before use and be sure to follow the instructions.
- Installation, inspection, maintenance, repairs, disassembly, adjustment and valve opening/closing should be carried out only by trained maintenance personnel.
- The precautions listed in this manual are designed to ensure safety and prevent equipment damage and personal injury. For situations that may occur as a result of erroneous handling, three different types of cautionary items are used to indicate the degree of urgency and the scale of potential damage and danger: DANGER, WARNING and CAUTION.
- The three types of cautionary items above are very important for safety: be sure to observe all of them as they relate to installation, use, maintenance, and repair. Furthermore, TLV accepts no responsibility for any accidents or damage occurring as a result of failure to observe these precautions.

Symbols

	Indicates a DANGER, WARNING or CAUTION item.
	Indicates an urgent situation which poses a threat of death or serious injury
	Indicates that there is a potential threat of death or serious injury
	Indicates that there is a possibility of injury or equipment / product damage

	DO NOT use for toxic, flammable or otherwise hazardous fluids. This product is a separator trap for air that separates and discharges condensate from air piping systems. Use only for air and/or air condensate. This product is for intended use only. Improper use may result in such hazards as damage to the product or malfunctions that may lead to serious accidents.
	NEVER apply direct heat to the float. The float may explode due to increased internal pressure, causing accidents leading to serious injury or damage to property and equipment.
	Install properly and DO NOT use this product outside the recommended operating pressure, temperature and other specification ranges. Improper use may result in such hazards as damage to the product or malfunctions that may lead to serious accidents. Local regulations may restrict the use of this product to below the conditions quoted.
	DO NOT use this product in excess of the maximum operating pressure differential. Such use could make discharge impossible (blocked).

 CAUTION	<p>Take measures to prevent people from coming into direct contact with product outlets. Failure to do so may result in burns or other injury from the discharge of fluids.</p>
	<p>When disassembling or removing the product, wait until the internal pressure equals atmospheric pressure and the surface of the product has cooled to room temperature. Disassembling or removing the product when it is hot or under pressure may lead to discharge of fluids, causing burns, other injuries or damage.</p>
	<p>Be sure to use only the recommended components when repairing the product, and NEVER attempt to modify the product in any way. Failure to observe these precautions may result in damage to the product and burns or other injury due to malfunction or the discharge of fluids.</p>
	<p>Do not use excessive force when connecting threaded pipes to the product. Over-tightening may cause breakage leading to fluid discharge, which may cause burns or other injury.</p>
	<p>Use only under conditions in which no freeze-up will occur. Freezing may damage the product, leading to fluid discharge, which may cause burns or other injury.</p>
	<p>Use only under conditions in which no water hammer will occur. The impact of water hammer may damage the product, leading to fluid discharge, which may cause burns or other injury.</p>

Specifications



WARNING

DO NOT use for toxic, flammable or otherwise hazardous fluids. This product is a separator trap for air that separates and discharges condensate from air piping systems. Use only for air and/or air condensate. This product is for intended use only. Improper use may result in such hazards as damage to the product or malfunctions that may lead to serious accidents.



CAUTION

Install properly and DO NOT use this product outside the recommended operating pressure, temperature and other specification ranges. Improper use may result in such hazards as damage to the product or malfunctions which may lead to serious accidents. Local regulations may restrict the use of this product to below the conditions quoted.



CAUTION

DO NOT use this product in excess of the maximum operating pressure differential; such use could make discharge impossible (blocked).



CAUTION

Use only under conditions in which no freeze-up will occur. Freezing may damage the product, leading to fluid discharge, which may cause burns or other injury.

Refer to the product nameplate for detailed specifications.

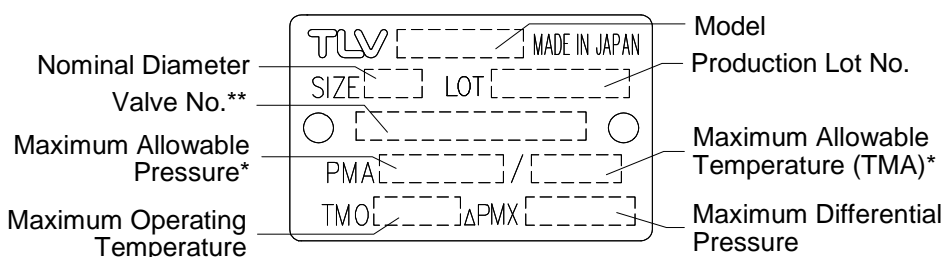

* Maximum allowable pressure (PMA) and maximum allowable temperature (TMA) are PRESSURE SHELL DESIGN CONDITIONS, **NOT** OPERATING CONDITIONS.

** Valve No. is displayed for products with options. This item is omitted from the nameplate when there are no options.

Configuration

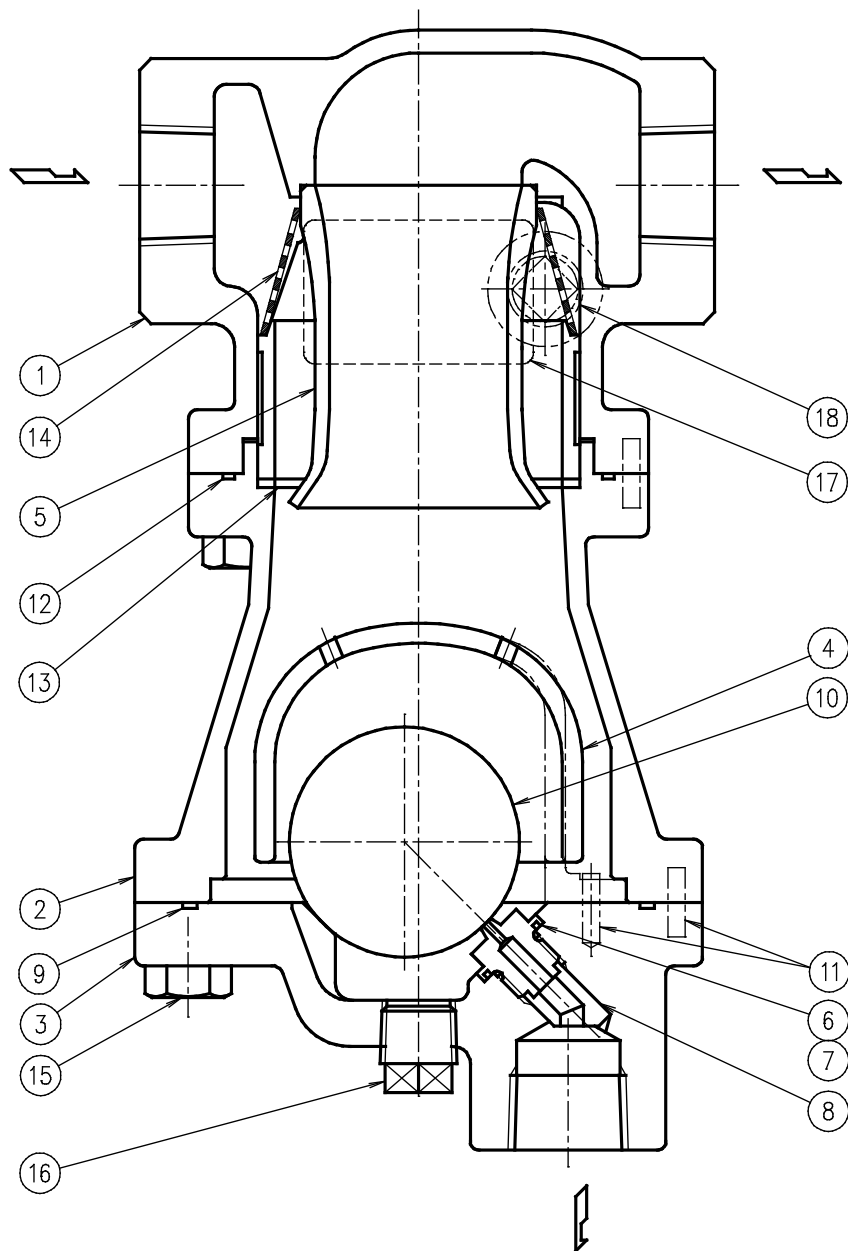

NO.	Name	NO.	Name
1	Body	10	Float
2	Separator Body	11	Guide Pin
3	Trap Cover	12	Body Gasket
4	Float Cover	13	Wave Spring
5	Separator	14	Screen
6	Trap Valve Seat	15	Trap Cover Bolt
7	Valve Seat Gasket	16	Lower Plug
8	Bushing	17	Nameplate
9	Trap Cover Gasket	18	Upper Plug (Option)

Installation



WARNING

DO NOT use for toxic, flammable or otherwise hazardous fluids. This product is a separator trap for air that separates and discharges condensate from air piping systems. Use only for air and/or air condensate. This product is for intended use only. Improper use may result in such hazards as damage to the product or malfunctions that may lead to serious accidents.



CAUTION

Install properly and DO NOT use this product outside the recommended operating pressure, temperature and other specification ranges. Improper use may result in such hazards as damage to the product or malfunctions which may lead to serious accidents. Local regulations may restrict the use of this product to below the conditions quoted.



CAUTION

Take measures to prevent people from coming into direct contact with product outlets. Failure to do so may result in burns or other injury from the discharge of fluids.



CAUTION

Do not use excessive force when connecting threaded pipes to the product. Over-tightening may cause breakage leading to fluid discharge, which may cause burns or other injury.

1. Before installation, be sure to remove all protective seals from the product.
2. Before installing the separator trap, blow out the inlet piping to remove any piping scraps, dirt and oil. Close the inlet valve after blowdown.
3. Install the separator trap at the point on the piping where the separation of condensate will have the greatest effect on efficiency. For example, on an air pipe or branch at the inlet of equipment requiring high-quality dry air.
4. Install the separator trap so the arrow on the product is pointing in the direction of air flow.
5. The separator trap should be inclined no more than 10° horizontally and front-to-back.
6. To facilitate inspection and maintenance, install a union at the trap outlet and ensure that there is sufficient space for maintenance.
7. Open the inlet valve and check to make sure that the separator trap functions properly.

If there is a problem, determine the cause by using the "Troubleshooting" guide in this manual.

Tolerance Angle for Installation - 10°

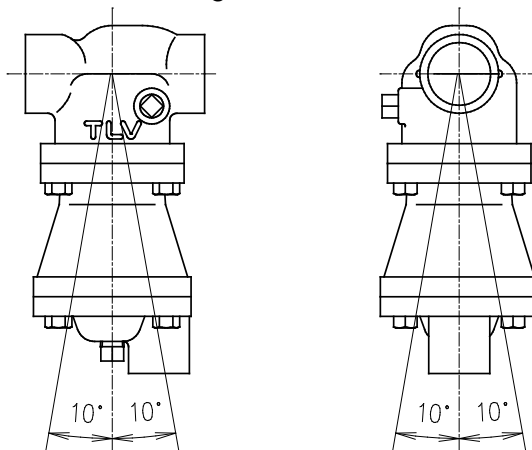

Make sure the trap is installed with the raised **TLV** lettering on the body horizontal.

Maintenance



Take measures to prevent people from coming into direct contact with product outlets. Failure to do so may result in burns or other injury from the discharge of fluids.



Be sure to use only the recommended components when repairing the product, and NEVER attempt to modify the product in any way. Failure to observe these precautions may result in damage to the product or burns or other injury due to malfunction or the discharge of fluids.

Operational Check

A visual inspection of the following items should be done on a daily basis to determine whether the separator trap is operating properly or has failed. Periodically (at least biannually) the operation should also be checked by using diagnostic equipment, such as a stethoscope or thermometer. (Installation, inspection, maintenance, repairs, disassembly, adjustment and valve opening/closing should be carried out only by trained maintenance personnel.)

Check to see if air is flowing from the separator outlet. Check all flow meters and check the differential pressure. If there is insufficient flow or differential pressure is too large, disassemble and check for clogging of the screen.

If the built-in air trap should fail, it may cause damage to piping and equipment, resulting in faulty or low quality products or losses due to air leakage.

(Air Trap Operational Check)

- Normal : Only condensate is discharged continuously from the trap outlet.
- Blocked : No condensate is discharged from the trap outlet.
(Discharge Impossible)
- Blowing : Air continuously flows from the trap outlet and doesn't stop.
- Air Leakage : Air is discharged through the trap outlet together with the condensate.

Parts Inspection

When parts have been removed, or during periodic inspections, use the following table to inspect the parts and replace any that are found to be defective.

Procedure	
Body Interior:	Check for the build-up
Screen:	Check for clogging or corrosion
Gaskets:	Check for warping or damage
Float:	Check for scratches or dents
Trap Valve Seat:	Check for the wear or scratches

Disassembly / Reassembly



NEVER apply direct heat to the float. The float may explode due to increased internal pressure, causing accidents leading to serious injury or damage to property and equipment.



When disassembling or removing the product, wait until the internal pressure equals atmospheric pressure and the surface of the product has cooled to room temperature. Disassembling or removing the product when it is hot or under pressure may lead to discharge of fluids, causing burns, other injuries or damage.

Use the following procedures to remove components. Use the same procedures in reverse to reassemble. (Installation, maintenance, repairs, disassembly, adjustment and valve opening/closing should be done only by trained maintenance personnel.)

Removing / Reattaching the Trap Cover

Part	During Disassembly	During Reassembly
Trap Cover Bolt	Remove with a socket wrench	Consult the table of tightening torques and tighten to the proper torque
Trap Cover	Remove the trap cover by pulling it down, being careful not to scratch the seating surface	Remove any remaining pieces of old gasket; reattach using the guide pin to aid alignment
Trap Cover Gasket	Remove, being careful not to scratch the surfaces	Replace with a new gasket if damaged

Removing / Reinserting Parts inside the Trap Cover

Part	During Disassembly	During Reassembly
Float Cover	Remove the cover by lift it upward	Using the guide pin, align the separator body with the body
Float	Remove, being careful not to scratch the polished surface	Insert, being careful not to scratch the polished surface
Trap Valve Seat	Remove with a socket wrench	Consult the table of tightening torques and tighten to the proper torque
Valve Seat Gasket	Remove, being careful not to scratch the surfaces	Replace with a new gasket if damaged

Separating / Reattaching Body and Separator Body

Part	During Disassembly	During Reassembly
Body Bolt	Remove with a socket wrench	Consult the table of tightening torques and tighten to the proper torque
Separator Body	Detach the separator body from the body, being careful not to let the separator fall	Using the guide pin, align the separator body with the body
Separator	Remove when detaching the separator body from the body	Insert into the groove in the separator body
Screen	Remove, being careful not to bend	Place on top of the separator, being careful not to bend
Wave Spring	Remove from its groove	Insert into the groove in the separator body
Body Gasket	Remove, being careful not to scratch the surfaces	Replace with a new gasket if damaged

Removing / Reattaching the Plug (Not necessary to disassemble in normal cases)

Part	During Disassembly	During Reassembly
Lower Plug (For drainage)	Remove with a socket wrench	Consult the table of tightening torques and tighten to the proper torque
Upper Plug* (For blow screen area)	Remove with a socket wrench	Consult the table of tightening torques and tighten to the proper torque

*Optional

Exploded View

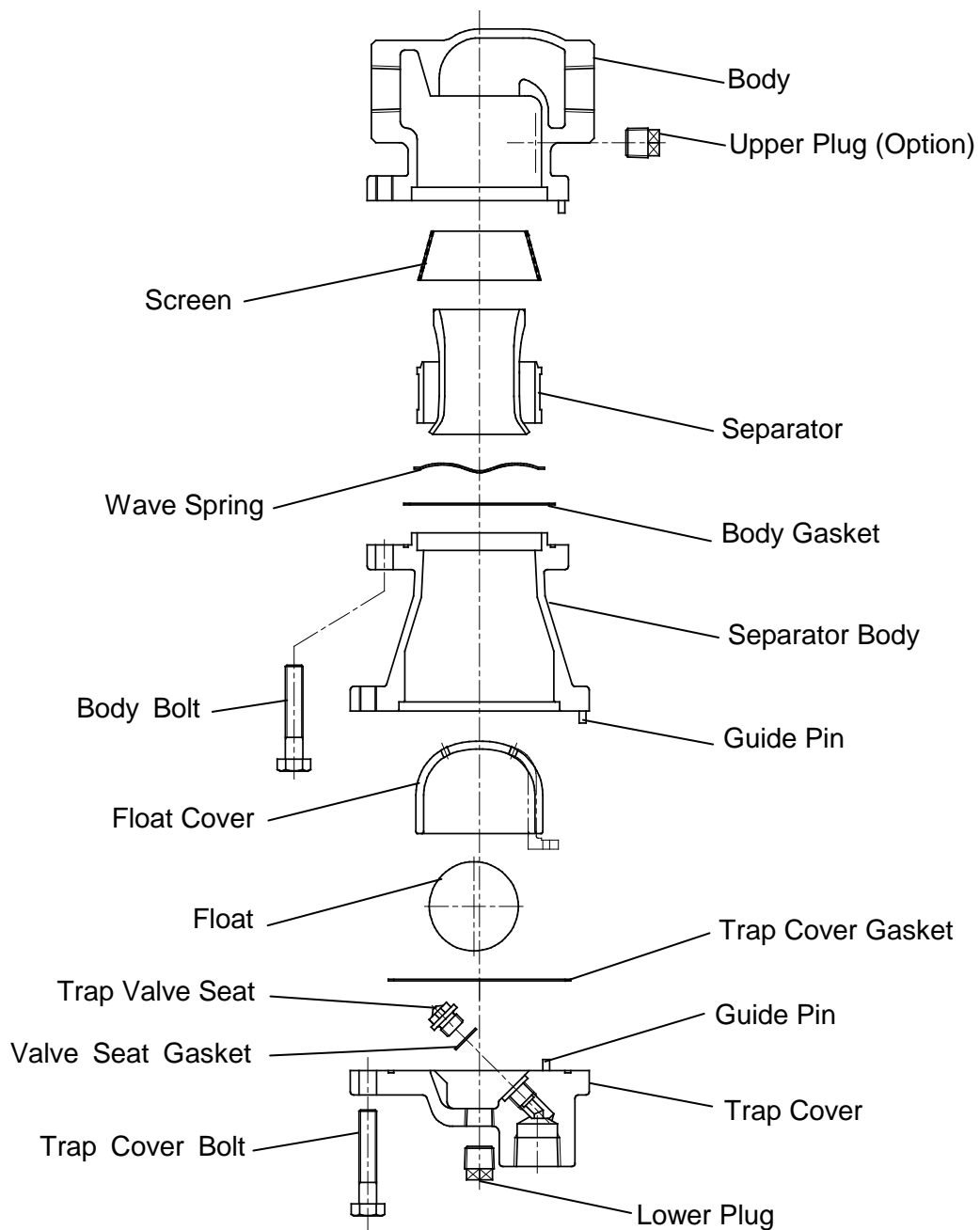

Table of Tightening Torques

Part Name	Distance Across Flats		Torque	
	mm	(in)	N-m	(lbf-ft)
Body Bolt	13	(1/2)	30	(22)
Trap Cover Bolt				
Trap Valve Seat	11	(7/16)	10	(7)
Plug (Upper / Lower)*	9	(11/32)	5**	(4)**

NOTE: - Coat all threaded portions with anti-seize. (N-m \approx 10 kg-cm)

- If drawings or other special documentation were supplied for the product, any torque given there takes precedence over values shown here.

*Upper plug is included only when it is required with option.

**These values represent tightening torques for threads that are wrapped with 3 - 3.5 turns of sealing tape.

Troubleshooting



WARNING

NEVER apply direct heat to the float. The float may explode due to increased internal pressure, causing accidents leading to serious injury or damage to property and equipment.



CAUTION

When disassembling or removing the product, wait until the internal pressure equals atmospheric pressure and the surface of the product has cooled to room temperature. Disassembling or removing the product when it is hot or under pressure may lead to discharge of fluids, causing burns, other injuries or damage.

When the product fails to operate properly, use the following table to locate and remedy the cause.

Problem	Cause	Remedy
No condensate is discharged (blocked) or discharge is poor	The float is damaged or filled with condensate	Replace with a new float
	The trap valve seat port, screen or piping is clogged with rust or scale	Clean parts
	The trap operating pressure exceeds the maximum specified pressure, or there is insufficient pressure differential between the trap inlet and outlet	Compare specifications and actual operating conditions
Air is discharged or leaks from the trap outlet (blowing) (air leakage)	Rust and scale have accumulated around the trap valve seat or beneath the float	Clean parts
	The trap valve seat is damaged	Replace with a new trap valve seat
	The float is deformed or coated with scale	Clean or replace with a new float
	The separator is installed above the maximum allowable inclination	Correct the installation
Air is leaking from sealing surfaces	Deterioration or damage to gaskets	Replace with a new gasket
	Improper tightening torques were used	Tighten to the proper torque
Water is mixed in with the air from the separator outlet	Air flow velocity is too high	Take steps necessary to lower the air flow velocity
	Review causes listed above in "No condensate is discharged..." and follow the appropriate remedy	
Separator outlet pressure drops or desired flow rate is unachievable	The screen is clogged with rust and scale	Clean or replace with a new screen

Product Warranty

1. Warranty Period
One year following product delivery.
2. Warranty Coverage
TLV CO., LTD. warrants this product to the original purchaser to be free from defective materials and workmanship. Under this warranty, the product will be repaired or replaced at our option, without charge for parts or labor.
3. This product warranty will not apply to cosmetic defects, nor to any product whose exterior has been damaged or defaced; nor does it apply in the following cases:
 - 1) Malfunctions due to improper installation, use, handling, etc., by other than TLV CO., LTD. authorized service representatives.
 - 2) Malfunctions due to dirt, scale, rust, etc.
 - 3) Malfunctions due to improper disassembly and reassembly, or inadequate inspection and maintenance by other than TLV CO., LTD. authorized service representatives.
 - 4) Malfunctions due to disasters or forces of nature.
 - 5) Accidents or malfunctions due to any other cause beyond the control of TLV CO., LTD.
4. Under no circumstances will TLV CO., LTD. be liable for consequential economic loss damage or consequential damage to property.

* * * * *

For Service or Technical Assistance:

Contact your **TLV** representative or your regional **TLV** office.

Manufacturer

TLV CO., LTD.
881 Nagasuna, Noguchi
Kakogawa, Hyogo 675 -8511 JAPAN
Tel: 81-(0)79-427-1800