

ISO 9001  
ISO 14001



Manufacturer

**TLV**® CO., LTD.

Kakogawa, Japan

is approved by LROA Ltd. to ISO 9001/14001

# TLV®

## Instruction Manual

Free Float Drain Trap

**JAH5RG-R / JAH5RG-M**

**JAH7RG-R / JAH7RG-M**

### Introduction

Thank you for purchasing the **TLV** Free Float Drain Trap.

This product has been thoroughly inspected before being shipped from the factory. When the product is delivered, before doing anything else, check the specifications and external appearance to make sure nothing is out of the ordinary. Also be sure to read this manual carefully before use and follow the instructions to be sure of using the product properly.

If this product is used with fluids other than air and/or water, all responsibility for regulatory compliance, product selection (including materials), handling, safety measures, etc. for the fluid(s) must be borne by the customer.

Under no circumstances will TLV CO., LTD. be liable for consequential economic loss damage or consequential damage to property or persons caused by explosions, poisoning or other accidents due to use with fluids.

This free float drain trap employs a precision-ground float and three-point seat. With no hinges or levers, the trap automatically and continuously discharges condensate as it forms in the air/gas system, preventing it from backing up in the system. The three-point seat supports the precision-ground float at three points, ensuring an air-tight seal even under extremely low condensate loads. This free float drain trap is also inline repairable, facilitating repair and maintenance, resulting in considerable time savings.

If detailed instructions for special order specifications or options not contained in this manual are required, please contact **TLV** for full details.

This instruction manual is intended for use with the model(s) listed on the front cover. It is necessary not only for installation but for subsequent maintenance, disassembly/reassembly and troubleshooting. Please keep it in a safe place for future reference.

Copyright © 2016 by TLV CO., LTD.

All rights reserved

Rev. 11/2016





## Contents



Safety Considerations .....	1
Checking the Piping .....	3
Operation .....	4
Specifications .....	4
Configuration .....	5
Installation .....	6
The Need for a Pressure-balancing Line .....	7
Secondary Side Precautions .....	7
Maintenance.....	8
Disassembly/Reassembly .....	9
Instructions for Plug/Holder Disassembly and Reassembly....	12
Troubleshooting .....	13
Product Warranty .....	14
Options.....	15

## Safety Considerations

- Read this section carefully before use and be sure to follow the instructions.
- Installation, inspection, maintenance, repairs, disassembly, adjustment and valve opening/closing should be carried out only by trained maintenance personnel.
- The precautions listed in this manual are designed to ensure safety and prevent equipment damage and personal injury. For situations that may occur as a result of erroneous handling, three different types of cautionary items are used to indicate the degree of urgency and the scale of potential damage and danger: DANGER, WARNING and CAUTION.
- The three types of cautionary items above are very important for safety: be sure to observe all of them as they relate to installation, use, maintenance, and repair. Furthermore, TLV accepts no responsibility for any accidents or damage occurring as a result of failure to observe these precautions.

## Symbols

	<b>Indicates a DANGER, WARNING or CAUTION item.</b>
	Indicates an urgent situation which poses a threat of death or serious injury
	Indicates that there is a potential threat of death or serious injury
	Indicates that there is a possibility of injury or equipment/product damage

 <b>DANGER</b>	<p><b>When used with toxic, flammable or otherwise hazardous fluids, manage properly and take appropriate safety measures for the hazardous fluids in use.</b> Failure to do so may result in serious injury and/or severe damage to property caused by blockage or fluid leakage.</p>
 <b>WARNING</b>	<p><b>NEVER apply direct heat to the float.</b> The float may explode due to increased internal pressure, causing accidents leading to serious injury or damage to property and equipment.</p>
 <b>CAUTION</b>	<p><b>Install properly and DO NOT use this product outside the recommended operating pressure, temperature and other specification ranges.</b> Improper use may result in such hazards as damage to the product or malfunctions that may lead to serious accidents. Local regulations may restrict the use of this product to below the conditions quoted.</p> <p><b>DO NOT use this product in excess of the maximum operating pressure differential.</b> Such use could make discharge impossible (blocked).</p> <p><b>Use hoisting equipment for heavy objects (weighing approximately 20 kg (44 lb) or more).</b> Failure to do so may result in back strain or other injury if the object should fall.</p> <p><b>Take measures to prevent people from coming into direct contact with product outlets.</b> Failure to do so may result in burns or other injury from the discharge of fluids.</p> <p><b>When disassembling or removing the product, wait until the internal pressure equals atmospheric pressure and the surface of the product has cooled to room temperature.</b> Disassembling or removing the product when it is hot or under pressure may lead to discharge of fluids, causing burns, other injuries or damage.</p> <p><b>Take measures to ensure the proper handling, such as recovery or dilution, of hazardous fluids discharged at product outlets.</b> Outflow of fluid or fluid leaks may lead to hazards such as flammable conditions or corrosion, which may result in injury, fires, damage or other accidents.</p> <p><b>Be sure to use only the recommended components when repairing the product, and NEVER attempt to modify the product in any way.</b> Failure to observe these precautions may result in damage to the product and burns or other injury due to malfunction or the discharge of fluids.</p> <p><b>Use only under conditions in which no freeze-up will occur.</b> Freezing may damage the product, leading to fluid discharge, which may cause burns or other injury.</p> <p><b>Use only under conditions in which no water hammer will occur.</b> The impact of water hammer may damage the product, leading to fluid discharge, which may cause burns or other injury.</p>

## Checking the Piping



When used with toxic, flammable or otherwise hazardous fluids, manage properly and take appropriate safety measures for the hazardous fluids in use. Failure to do so may result in serious injury and/or severe damage to property caused by blockage or fluid leakage.



Use only under conditions in which no water hammer will occur. The impact of water hammer may damage the product, leading to fluid discharge, which may cause burns or other injury.

Check to make sure that the pipes to be connected to the trap have been installed properly.

1. Is the pipe diameter suitable?
2. Is the piping where the trap is to be installed horizontal?
3. Has sufficient space been secured for maintenance?
4. Have isolation valves been installed at the inlet and outlet? If the outlet is subject to back pressure, has a check valve been installed?
5. Is the inlet pipe as short as possible, with as few bends as possible, and installed so the liquid will flow naturally down into the trap?
6. Has the piping work been done correctly, as shown in the figures below?

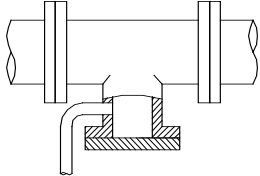
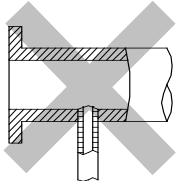
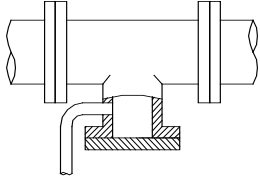
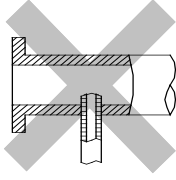
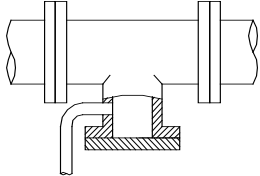
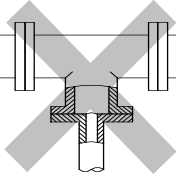
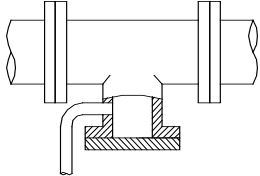
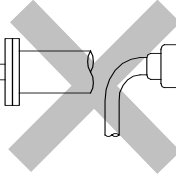
Requirement	Correct	Incorrect
Install catchpot with the proper diameter.		 Diameter is too small.
Make sure the flow of condensate is not obstructed.		 Diameter is too small and inlet protrudes into pipe interior.
To prevent rust and scale from flowing into the trap, the inlet pipe should be connected 25 – 50 mm (1 – 2 in) above the base of the T-pipe.		 Rust and scale flow into the trap with the condensate.
When installing on the blind end, make sure the flow of condensate is not obstructed.		 Condensate collects in the pipe.

## Operation

Principles of condensate discharge:

### 1. Start-up

At start-up, the float is sealing the valve seat.

NOTE: If there is no condensate in the trap body, prime with some water through the pressure-balancing line before startup. (Do this after installation and disassembly/inspection)

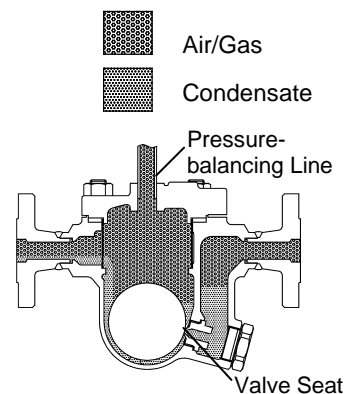

### 2. Condensate Discharge

As air/gas is supplied, condensate flow begins. The rising condensate level causes the float to rise due to buoyancy, opening the valve seat and allowing condensate to be discharged.

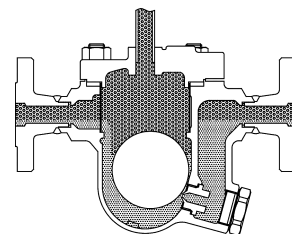

### 3. Closed Position

When the condensate flow rate decreases, the float falls, closing off the valve seat opening. A water seal is maintained at all times over the valve seat to prevent air/gas leakage.

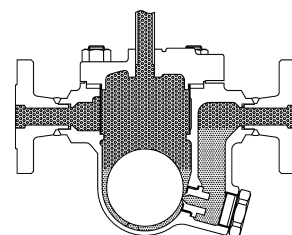

## Specifications



Install properly and **DO NOT** use this product outside the recommended operating pressure, temperature and other specification ranges. Improper use may result in such hazards as damage to the product or malfunctions which may lead to serious accidents. Local regulations may restrict the use of this product to below the conditions quoted.



**DO NOT** use this product in excess of the maximum operating pressure differential; such use could make discharge impossible (blocked).



Use only under conditions in which no freeze-up will occur. Freezing may damage the product, leading to fluid discharge, which may cause burns or other injury.

Refer to the product nameplate for detailed specifications.

### JAH5RG-R/JAH5RG-M

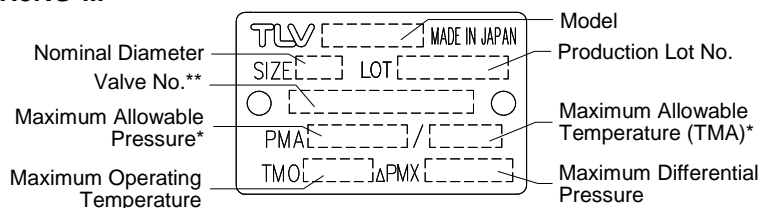

**JAH7RG-R/JAH7RG-M**

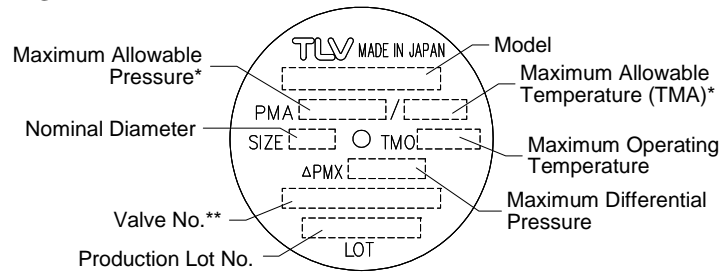

\* Maximum allowable pressure (PMA) and maximum allowable temperature (TMA) are PRESSURE SHELL DESIGN CONDITIONS, **NOT** OPERATING CONDITIONS.

\*\* Valve No. is displayed for products with options. This item is omitted from the nameplate when there are no options.

**Minimum Required Condensate Load**

For products with metal valve seat, a minimum required condensate load is necessary to maintain a liquid seal. There is a chance of air/gas leak if the condensate load falls below this rate. Please refer to the chart below.

Model	JAH5RG-M	JAH7RG-M
Minimum Required Condensate Load (kg/h)	1 kg/h (2 lb/h)	5 kg/h (11 lb/h)

**Configuration**

**JAH5RG-M (Metal valve seat)**

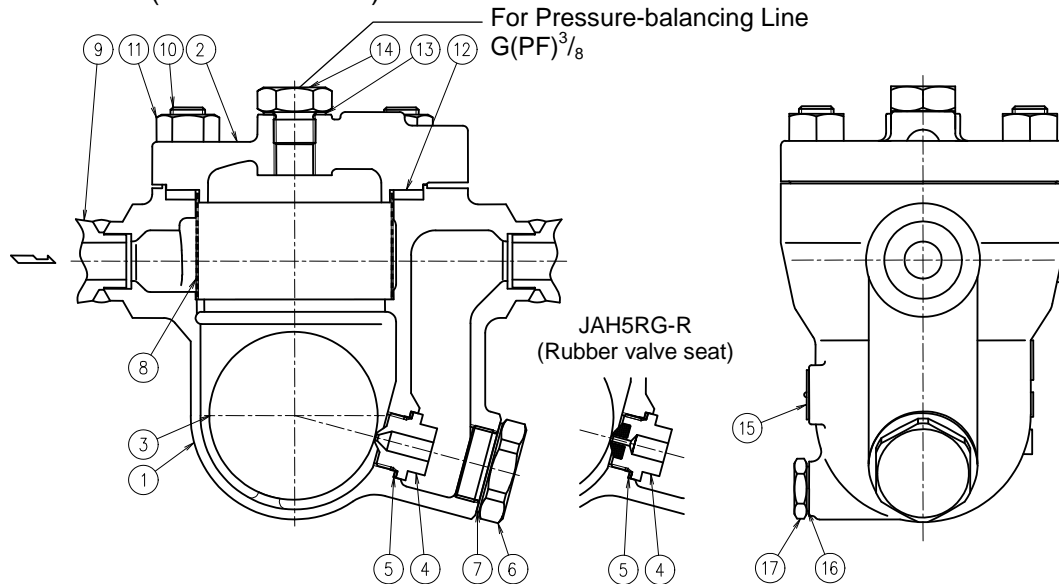

No.	Name	No.	Name	No.	Name
1	Body	7	Valve Seat (Orifice) Plug Gasket	13	Gasket
2	Cover	8	Screen	14	Balancing Line Plug
3	Float	9	Flange/Socket	15	Nameplate
4	Valve Seat (Orifice)	10	Cover Bolt	16	Drain Plug Gasket*
5	Valve Seat (Orifice) Gasket	11	Cover Nut	17	Drain Plug*
6	Valve Seat (Orifice) Plug	12	Cover Gasket		

\* Option

### JAH7RG-M (Metal valve seat)

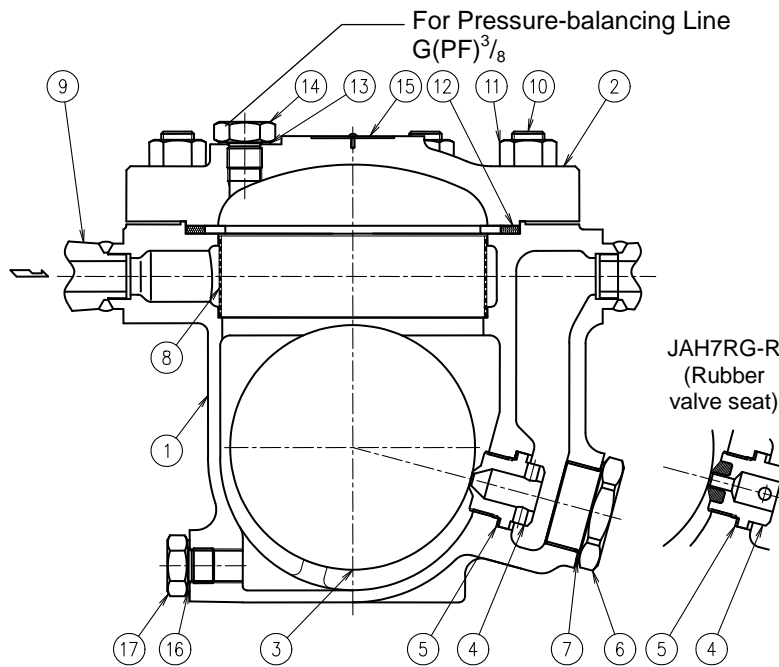

No.	Name
1	Body
2	Cover
3	Float
4	Valve Seat (Orifice)
5	Valve Seat (Orifice) Gasket
6	Valve Seat (Orifice) Plug
7	Valve Seat (Orifice) Plug Gasket
8	Screen
9	Flange / Socket
10	Cover Bolt
11	Cover Nut
12	Cover Gasket
13	Gasket
14	Balancing Line Plug
15	Nameplate
16	Drain Plug Gasket
17	Drain Plug

## Installation



When used with toxic, flammable or otherwise hazardous fluids, manage properly and take appropriate safety measures for the hazardous fluids in use. Failure to do so may result in serious injury and/or severe damage to property caused by blockage or fluid leakage.



Install properly and **DO NOT** use this product outside the recommended operating pressure, temperature and other specification ranges. Improper use may result in such hazards as damage to the product or malfunctions which may lead to serious accidents. Local regulations may restrict the use of this product to below the conditions quoted.



Use hoisting equipment for heavy objects (weighing approximately 20 kg (44 lb) or more). Failure to do so may result in back strain or other injury if the object should fall.



Take measures to prevent people from coming into direct contact with product outlets. Failure to do so may result in burns or other injury from the discharge of fluids.

Installation, inspection, maintenance, repairs, disassembly, adjustment and valve opening/closing should be carried out only by trained maintenance personnel.

1. Before installation, be sure to remove all protective seals.
2. Before installing the product, open the inlet valve and blow out the piping to remove any piping scraps, dirt and oil. Close the inlet valve after blowdown.
3. Install the product so the arrow on the body is pointing in the direction of flow.
4. The trap should be inclined no more than 5° horizontally and front-to-back.
5. Install a condensate outlet valve and outlet piping.
6. To ensure proper condensate flow into the trap, remove the balancing line plug and install a pressure-balancing line. Connect the end of the pressure-balancing line to the air/gas main or an area with an air/gas pocket. For more details, see the section "The Need for a Pressure-balancing Line".

7. To facilitate inspection and maintenance, install a union or a flange where the product has connections (inlet, pressure-balancing line, condensate outlet). For more details, see the section “The Need for a Pressure-balancing Line”.
8. After priming through the pressure-balancing port, open the inlet and outlet valves and check to make sure that the product functions properly.

If there is a problem, determine the cause using the “Troubleshooting” section in this manual.

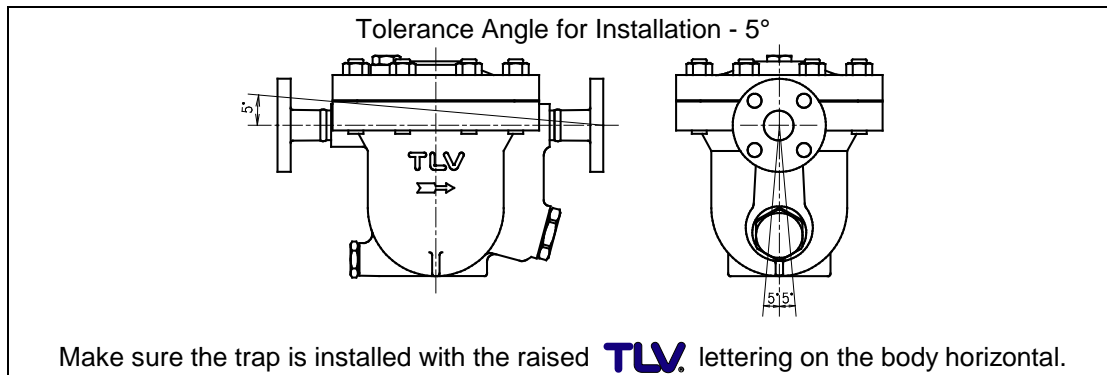

## The Need for a Pressure-balancing Line

This drain trap is designed to automatically discharge inflowing condensate. However, if the condensate completely fills the inlet path of the trap, air or gas in the trap body will not be able to escape, preventing displacement by condensate, and thus preventing condensate from entering the trap. This phenomena is called air binding. Air binding occurs more often in piping with long horizontal lengths, smaller diameters or multiple bends. To prevent air binding and ensure air or gas can be displaced by incoming condensate, a pressure-balancing line should be installed between the trap cover and the dry portion of the receiver tank.

Connect the pressure-balancing line in the following manner:

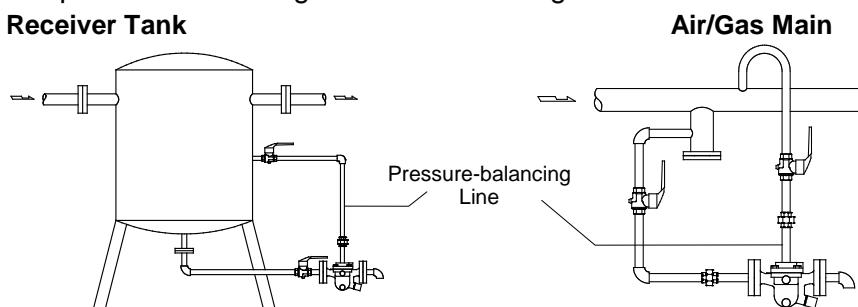

## Secondary Side Precautions



Take measures to ensure the proper handling, such as recovery or dilution, of hazardous fluids discharged at product outlets. Outflow of fluid or fluid leaks may lead to hazards such as flammable conditions or corrosion, which may result in injury, fires, damage or other accidents.

Be sure to take precautions on the secondary side when using flammable, toxic or other hazardous gases.

Sample precautionary procedures:

1. Flare method
2. Collection in a seal pot
3. Collection in a sealed container



## Maintenance



Take measures to prevent people from coming into direct contact with product outlets. Failure to do so may result in burns or other injury from the discharge of fluids.



Be sure to use only the recommended components when repairing the product, and NEVER attempt to modify the product in any way. Failure to observe these precautions may result in damage to the product or burns or other injury due to malfunction or the discharge of fluids.

## Operational Check

A visual inspection of the following items should be done on a daily basis to determine whether the trap is operating properly or has failed. Periodically (at least biannually) the operation should also be checked by using diagnostic equipment, such as a stethoscope or thermometer.

If the trap should fail, it may cause damage to piping and equipment, resulting in faulty or low quality products or losses due to air or gas leakage.

- Normal : Condensate is discharged continuously and the sound of flow can be heard. If there is very little condensate, there is almost no sound of flow.
- Blocked : No condensate is discharged.
- (Discharge Impossible)
- Blowing : Air or gas continually flows from the outlet and there is a continuous metallic sound.
- Air or Gas Leakage\* : Air or gas is discharged through the trap outlet together with condensate, accompanied by a high-pitched sound.

\* The JAH5RG-M and JAH7RG-M with metal valve seats have a minimum condensate load requirement to ensure proper sealing (see "Specifications").

## Parts Inspection

When parts have been removed, or during periodic inspections, use the following table to inspect the parts and replace any that are found to be defective.

Procedure	
Gaskets:	check for warping or scratches
Screen:	check for clogging or corrosion
Valve Seat:	check for warping or scratches
Float:	check for scratches or dents
Body Interior:	check for build-up
Valve Seat Opening:	check for dirt, oil film, wear or scratches

## Disassembly/Reassembly



**WARNING** NEVER apply direct heat to the float. The float may explode due to increased internal pressure, causing accidents leading to serious injury or damage to property and equipment.



**CAUTION** Use hoisting equipment for heavy objects (weighing approximately 20 kg (44 lb) or more). Failure to do so may result in back strain or other injury if the object should fall.



**CAUTION** When disassembling or removing the product, wait until the internal pressure equals atmospheric pressure and the surface of the product has cooled to room temperature. Disassembling or removing the product when it is hot or under pressure may lead to discharge of fluids, causing burns, other injuries or damage.

Use the following procedures to remove components. Use the same procedures in reverse to reassemble. (Installation, inspection, maintenance, repairs, disassembly, adjustment and valve opening/closing should be carried out only by trained maintenance personnel.)

### Drain Plug: JAH7RG-R/JAH7RG-M (Option for JAH5RG-R/JAH5RG-M)

Part	During Disassembly	During Reassembly
Drain Plug	Remove with a socket wrench	Consult the table of tightening torques and tighten to the proper torque
Drain Plug Gasket	Remove the gasket	Replace with a new gasket; coat surfaces with anti-seize

### Detaching/Reattaching the Cover and its Components

NOTE: Disconnect any lines that must be disconnected before disassembly can take place (inlet piping, pressure-balancing line, condensate discharge piping, etc.).

Part	During Disassembly	During Reassembly
Cover Nut	Remove with a socket wrench	Consult the table of tightening torques and tighten to the proper torque
Cover	Remove by lifting up and off	Align the arrows on the body and cover and reattach
Cover Gasket	Remove the gasket and clean sealing surfaces on the body and cover	Replace with a new gasket; Make sure there are no pieces of the old gasket left on the sealing surfaces of the body and cover
Balancing Line Plug	Remove with a wrench	Consult the table of tightening torques and tighten to the proper torque
Plug Gasket	Remove the gasket	Replace with a new gasket; coat surfaces with anti-seize

### Disassembly/Reassembly of Internal Components

Part	During Disassembly	During Reassembly
Screen	Remove by lifting straight up and out while turning	Align the screen/float cover and insert, making sure the top of the screen does not stick up out of the body
Float	Remove, being careful not to scratch the polished surface	Insert, being careful not to scratch or misshape
Orifice Plug	Remove with a socket wrench	Consult the table of tightening torques and tighten to the proper torque
Valve Seat Plug Gasket	Remove the gasket	Replace with a new gasket; coat surfaces with anti-seize
Valve Seat	Remove with a socket wrench	Consult the table of tightening torques and tighten to the proper torque; be careful not to scratch the surface
Valve Seat Gasket	Remove the gasket	Replace with a new gasket; coat surfaces with anti-seize

**Table of Tightening Torques**

Part Name	JAH5RG-R/JAH5RG-M				JAH7RG-R/JAH7RG-M			
	Torque		Distance Across Flats		Torque		Distance Across Flats	
	N·m	(lbf·ft)	mm	(in)	N·m	(lbf·ft)	mm	(in)
Valve Seat	140	(100)	17	( <sup>21</sup> / <sub>32</sub> )	280	(210)	26	(1)
Valve Seat Plug	180	(130)	38	(1 <sup>1</sup> / <sub>2</sub> )	420	(310)	50	(1 <sup>31</sup> / <sub>32</sub> )
Cover Nut	160	(115)	21	( <sup>13</sup> / <sub>16</sub> )	200	(150)	24	( <sup>15</sup> / <sub>16</sub> )
Balancing Line Plug	100	(73)	26	(1)	100	(73)	26	(1)
Drain Plug	35	(26)	21	( <sup>13</sup> / <sub>16</sub> )	100	(73)	26	(1)

(1 N·m ≈ 10 kg·cm)

- NOTE: - Coat all threaded portions and valve seat gasket with anti-seize.  
 - Tightening torques for metal and rubber valve seats are identical.  
 - If drawings or other special documentation were supplied for the product, any torque given there takes precedence over values shown here.

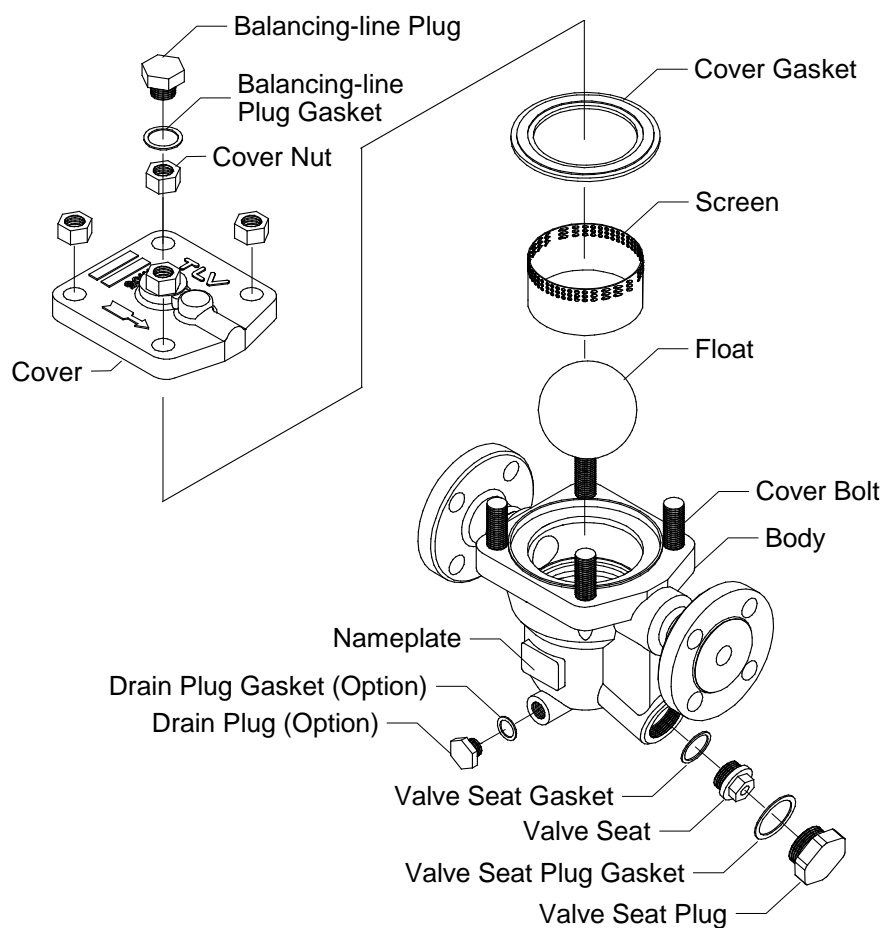
**Exploded View****JAH5RG-R/JAH5RG-M**

JAH7RG-R/JAH7RG-M

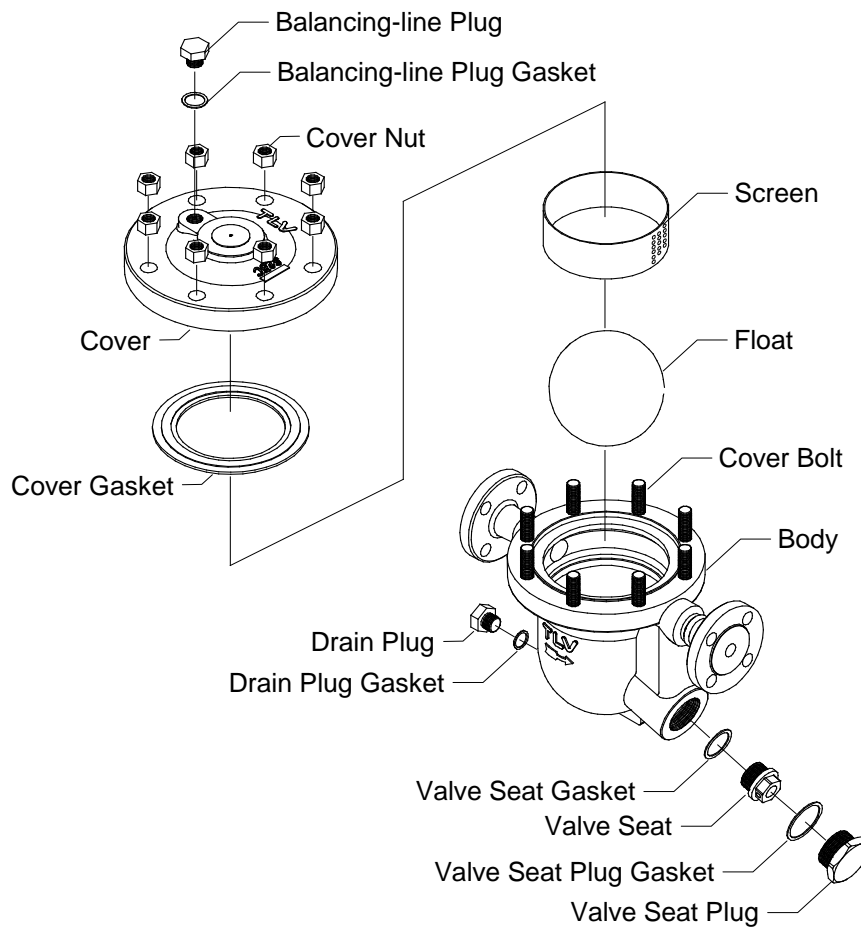

## Instructions for Plug/Holder Disassembly and Reassembly

The seal on the threaded plugs/holders found on TLV products is formed by a flat metal gasket. There are various installation orientations for the gaskets, such as horizontal, diagonal and downward, and the gasket may be pinched in the thread recesses during assembly.

### Instructions for Disassembly and Reassembly

- ① Remove the plug/holder using a tool of the specified size (distance across flats).
- ② The gasket should not be reused. Be sure to replace it with a new gasket.
- ③ Clean the gasket surfaces of the plug/holder and the product body using a rag and/or cleaning agents, then check to make sure the surfaces are not scratched or deformed.
- ④ Coat both the gasket surface of the plug/holder and the threads of the plug/holder with anti-seize, then press the gasket onto the center of the gasket surface of the plug/holder, making sure the anti-seize affixes the gasket tightly to the plug/holder. Check to make sure the gasket is not caught in the recesses of the threads.
- ⑤ Hold the plug/holder upside down to make sure that the anti-seize makes the gasket stick to the plug/holder even when the plug/holder is held upside down.
- ⑥ Screw the plug/holder by hand into the product body while making sure that the gasket remains tightly affixed to the center of the gasket surface of the plug/holder. Make sure the entire gasket is making contact with the gasket surface of the product body. It is important at this point to make sure the gasket is not pinched in the thread recesses of the plug/holder.
- ⑦ Tighten the plug/holder to the proper torque.
- ⑧ Next, begin the supply of air/gas and check to make sure there is no leakage from the part just tightened. If there is leakage, immediately close the inlet valve and, if there is a bypass valve, take the necessary steps to release any residual pressure. After the surface of the product cools to room temperature, repeat the procedure beginning from step 1.

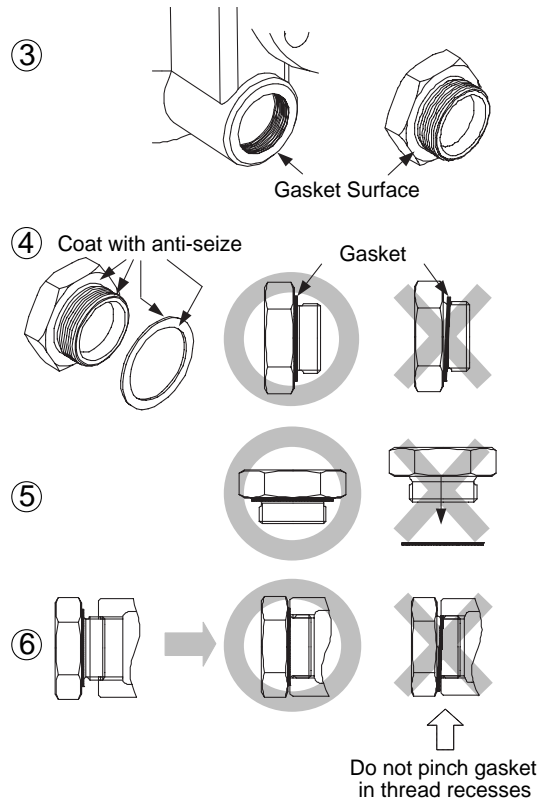

## Troubleshooting



NEVER apply direct heat to the float. The float may explode due to increased internal pressure, causing accidents leading to serious injury or damage to property and equipment.

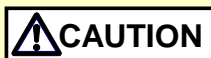

When disassembling or removing the product, wait until the internal pressure equals atmospheric pressure and the surface of the product has cooled to room temperature. Disassembling or removing the product when it is hot or under pressure may lead to discharge of fluids, causing burns, other injuries or damage.

When the product fails to operate properly, use the following table to locate and remedy the cause.

Problem	Cause	Remedy
No condensate is discharged (blocked) or discharge is poor	The float is damaged or filled with condensate	Replace with a new float
	The valve seat opening, screen or piping are clogged with rust and scale	Clean parts
	Air binding has occurred	Make sure a pressure-balancing line is installed; if already installed, make sure it has not become dislodged or is not incorrectly installed
	The trap operating pressure exceeds the maximum specified pressure, or whether there is insufficient pressure differential between the trap inlet and outlet	Compare specifications and actual operating conditions
	The specific gravity of the fluid is not suitable for this product	Consult TLV
Air/gas is discharged or leaks from the outlet* (blowing) (air/gas leakage)	Clogged valve seat opening or rust and scale build-up beneath the float	Clean parts
	Scratches on the valve seat	Replace with a new valve seat
	The float is misshapen or has a build-up	Clean float or replace with a new float
	Improper installation orientation	Correct the installation
	Trap vibration	Lengthen the inlet piping and fasten it securely
	There is no condensate in the drain trap body, no water seal around the valve seat	Prime the drain trap
Air/gas is leaking from a place other than the outlet	Check for gasket deterioration or damage	Replace with new gasket(s)
	Check to make sure that the proper tightening torques were used	Tighten to the proper torque
Float frequently becomes damaged	Check to see if water hammer has occurred	Study and correct the piping

\* The JAH5RG-M and JAH7RG-M with metal valve seats have a minimum condensate load requirement to ensure proper sealing (see "Specifications").

## Product Warranty

1. Warranty Period  
One year following product delivery.
2. Warranty Coverage  
TLV CO., LTD. warrants this product to the original purchaser to be free from defective materials and workmanship. Under this warranty, the product will be repaired or replaced at our option, without charge for parts or labor.
3. This product warranty will not apply to cosmetic defects, nor to any product whose exterior has been damaged or defaced; nor does it apply in the following cases:
  - 1) Malfunctions due to improper installation, use, handling, etc., by other than TLV CO., LTD. authorized service representatives.
  - 2) Malfunctions due to dirt, scale, rust, etc.
  - 3) Malfunctions due to improper disassembly and reassembly, or inadequate inspection and maintenance by other than TLV CO., LTD. authorized service representatives.
  - 4) Malfunctions due to disasters or forces of nature.
  - 5) Accidents or malfunctions due to any other cause beyond the control of TLV CO., LTD.
4. Under no circumstances will TLV CO., LTD. be liable for consequential economic loss damage or consequential damage to property.

\* \* \* \* \*

For Service or Technical Assistance:

Contact your **TLV** representative or your regional **TLV** office.

### Manufacturer

**TLV** CO., LTD.  
881 Nagasuna, Noguchi  
Kakogawa, Hyogo 675-8511 JAPAN  
Tel: 81-(0)79 - 427 - 1800

## Options

The options shown below are available for this product on request. Please compare with the product you received.

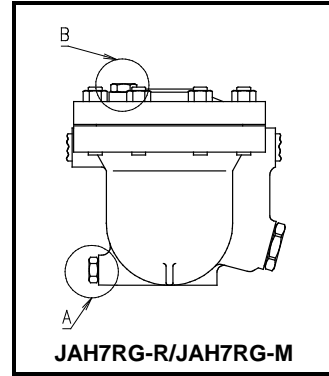
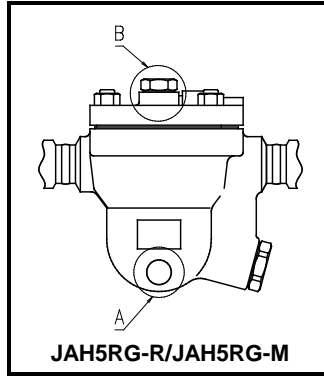

### Options for Area A

#### JAH5RG-R/JAH5RG-M

(Standard: without drain plug)

With G(PF)  
Drain Plug

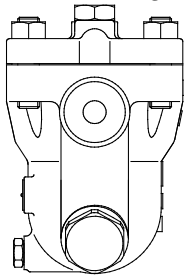

With R(PT) or NPT  
Drain Plug

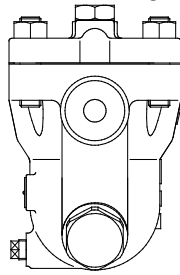

#### JAH7RG-R/JAH7RG-M

(Standard: with G(PF) drain plug)

Without Drain Plug

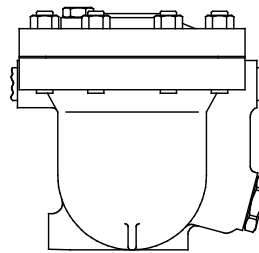

With R(PT) or NPT  
Drain Plug

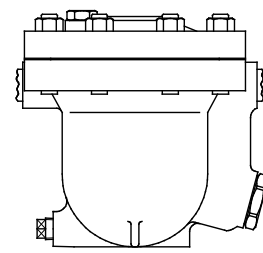

### Options for Area B

Balancing Line Plug with Tapered Thread Option

JAH5RG-R/JAH5RG-M (Standard: with G(PF) plug)

With R(PT) or NPT Plug	Socket	Flange

JAH7RG-R/JAH7RG-M (Standard: with G(PF) plug)

With R(PT) or NPT Plug	Socket	Flange