



# PowerTrap®

## MODEL GT10L

### COMBINATION PUMPING AND TRAPPING SECONDARY PRESSURE DRAINER

#### Benefits

Pump/trap with built-in steam trap for a wide range of applications: drainage of low capacity heat exchangers, flash steam recovery systems and reservoirs, often operating under vacuum conditions.

1. No cavitation or seal leakage.
2. Non-electric design with durable nickel-based alloy compression spring for reliable performance.
3. Pump will operate with a low filling head (min. 12").
4. Easy, inline access to internal parts simplifies cleaning and reduces maintenance costs.
5. Intake/exhaust valve heads are both Rockwell 65C with 45C seats for maximum durability.
6. High quality stainless steel internals ensure reliability.
7. Compact design permits installation in a limited space.
8. Float resists hydraulic shock to 1500 psig.
9. 2-year warranty for snap-action mechanism.\*

\* Contact TLV for details



#### Specifications

Model		GT10L	
Connection	Pumped Medium Inlet & Outlet	<b>Screwed and Flanged*</b>	<b>Screwed</b>
	Motive Medium & Pump Exhaust	Screwed	
Size (in)	Pumped Medium: Inlet x Outlet	<b>1 x 1</b>	<b>1½ x 1</b>
	Motive Medium Inlet	½	
	Pump Exhaust Outlet	½	
Maximum Operating Pressure (psig)	PMO	150	
Maximum Operating Temperature (°F)	TMO	365	
Maximum Allowable Pressure (psig)	PMA	Cast Iron: 230 Cast Steel: 300	
Maximum Allowable Temperature (°F)	TMA	428	
Motive Medium Pressure Range (psig)		5 – 150	
Maximum Allowable Back Pressure		7 psi less than motive medium pressure used	
Volume of Each Discharge Cycle (gal)		approximately 1.6	
Motive Medium**		Saturated Steam	
Pumped Medium***		Steam Condensate	

\* For details of flange connection, see picture at bottom right

\*\* Do not use with toxic, flammable or otherwise hazardous fluids.

\*\*\* Do not use for fluids with specific gravities under 0.85 or over 1, or for toxic, flammable or otherwise hazardous fluids.



To avoid abnormal operation, accidents or serious injury, DO NOT use this product outside of the specification range. Local regulations may restrict the use of this product to below the conditions quoted.

No.	Description	Material	ASTM/AISI*	JIS		
①	Body	Cast Iron	A126 Cl.B	FC250		
		Cast Steel**	A216 Gr.WCB	—		
②	Cover	Cast Iron	A126 Cl.B	FC250		
		Cast Steel**	A216 Gr.WCB	—		
③	Cover Gasket	Graphite Compound	—	—		
④	Float	Stainless Steel	AISI316L	SUS316L		
⑤	Snap-action Unit	Stainless Steel	—	—		
⑥	Motive Medium Intake Valve Unit	Intake Valve	Stainless Steel	AISI440C	SUS440C	
		Valve Seat	Stainless Steel	AISI420F	SUS420F	
⑦	Exhaust Valve Unit	Exhaust Valve	Stainless Steel	AISI440C	SUS440C	
		Valve Seat	Stainless Steel	AISI420F	SUS420F	
⑧	Trap Unit	Stainless Steel	—	—		
⑨	Inlet Check Valve	Screwed	CK3MG***	Cast Stainless Steel	A351 Gr.CF8	—
		Flanged	CKF5M	Stainless Steel	AISI304	SUS304
⑩	Outlet Check Valve	Screwed	CK3MG***	Cast Stainless Steel	A351 Gr.CF8	—
		Flanged	CKF3M	Cast Stainless Steel	A351 Gr.CF8	—

\* Equivalent \*\* Option: Cast Stainless Steel \*\*\* Not shown

Connections and sizes in bold are standard

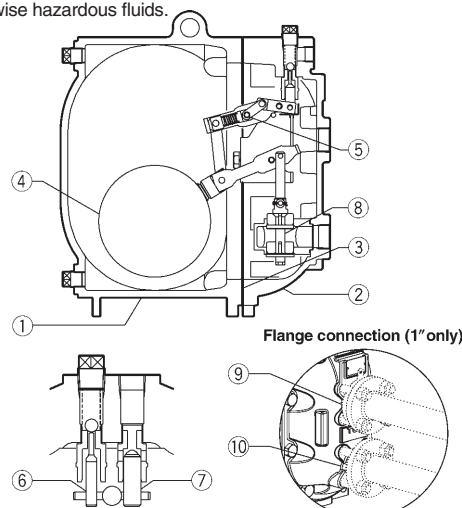

Copyright © TLV

## Discharge Capacity

Filling Head: 25" from Grade

Inlet Pipe Size		A	1 1/2"	B	1"	C	1"
Inlet Check Valve			1 1/2" CK3MG		1" CK3MG		1" CKF5M
Outlet Check Valve			1" CK3MG		1" CK3MG		1" CKF3M
Motive Medium			Steam		Steam		Steam
Motive Medium Inlet Pressure (P <sub>m</sub> ) (psig)	Total Lift or Back Press. (P <sub>2</sub> ) (psig)		lb/h		lb/h		lb/h
150	15		3,080		2,310		2,160
	25		2,850		2,110		1,890
	40		2,520		1,860		1,740
	60		2,160		1,560		1,300
	80		1,820		1,290		1,050
	100		1,520		1,120		810
125	15		2,890		2,260		2,090
	25		2,670		2,010		1,800
	40		2,360		1,740		1,650
	60		2,010		1,440		1,150
	80		1,700		1,180		920
	100		1,360		1,030		690
100	15		2,740		2,160		2,020
	25		2,480		1,930		1,690
	40		2,070		1,610		1,530
	60		1,640		1,270		1,000
	80		1,230		1,030		750
75	15		2,600		2,090		1,870
	25		2,320		1,750		1,540
	40		1,870		1,450		1,270
	60		1,360		1,110		840
50	10		2,620		2,110		1,830
	15		2,520		1,930		1,650
	25		1,970		1,610		1,300
	40		1,390		1,190		980
25	5		2,670		2,080		1,980
	10		2,360		1,850		1,620
	15		2,060		1,600		1,340
10	2		2,620		2,030		1,890

### • Correction Factors

For GT10L installed with filling head other than 25" (minimum filling head: CK3MG: 18", CKF5M: 12")

Filling Head from Grade	Inlet Pipe & Check Valve Size		
	1 1/2" CK3MG	1" CK3MG	1" CKF5M
55"	1.30	1.50	1.37
43"	1.27	1.35	1.28
37"	1.23	1.25	1.21
31"	1.15	1.15	1.12
25"	1.00	1.00	1.00
22"	0.90	0.85	0.93
18"	0.60	0.60	0.81
12"	—	—	0.59

### • Illustration of Filling Head and Pressures

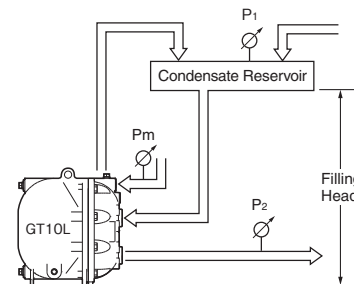

The discharge capacity is determined by the motive medium, motive medium pressure (P<sub>m</sub>) and back pressure (P<sub>2</sub>).

Make sure that:  
 Discharge Capacity × Correction Factor > Required Flow Rate

### NOTE:

- A check valve must be installed at both the pumped medium inlet and outlet. To achieve the above capacities with the standard GT10L configuration, either TLV check valves CK3MG (inlet & outlet), or CKF5M (inlet) and CKF3M (outlet) must be used, depending on connection type.
- Motive medium pressure minus back pressure must be greater than 7 psi.
- A strainer must be installed at the motive medium and pumped medium inlets.

## Dimensions

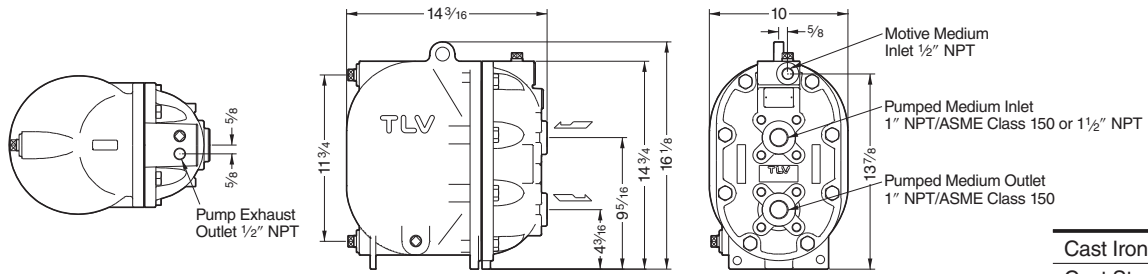

Note: All Plug Holes 1/2" NPT

Weight (lb)	
Cast Iron	101
Cast Steel	110

## Size of Reservoir

The reservoir must have a capacity sufficient to store the condensate produced during the **PowerTrap** operation and discharge.

### Reservoir Dimensions (flash steam is not involved)

Amount of condensate lb/h	Reservoir diameter (in) and length (ft)						
	1 1/2	2	3	4	6	8	10
500 or less	3.0 ft	2.0					
700	4.0	2.5	1.0				
1000	5.5	3.5	1.5				
1200		4.5	2.0	1.0			
1500			2.5	1.5			
2000			3.5	2.0			
3000			4.5	3.0			
4000			6.5	4.0	1.5		
5000				5.0	2.5		
6000				5.5	2.5	1.5	
7000				6.5	3.0	1.5	
8000					3.5	2.0	
9000					4.0	2.5	1.5
10000					4.5	2.5	1.5
12000					5.0	3.0	2.0
14000					6.0	3.5	2.5
16000					6.5	4.0	2.5
18000						4.5	3.0
20000						5.0	3.5

Reservoir length can be reduced by 50% when the motive pressure (P<sub>m</sub>) divided by the back pressure (P<sub>2</sub>) equals 2 or greater (when P<sub>m</sub> ÷ P<sub>2</sub> ≥ 2).

## Steam Consumption (Motive Medium)

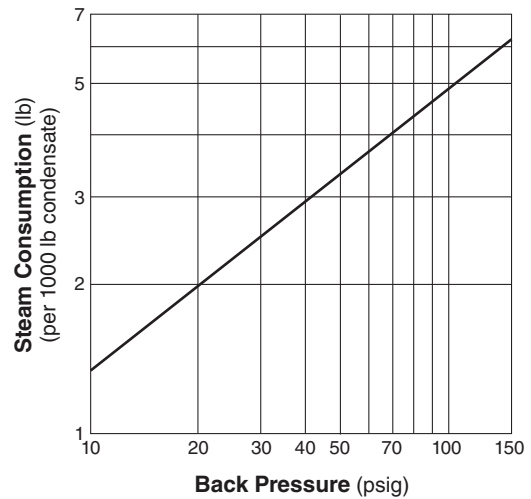

## GT10L Steam Trap Discharge Capacity

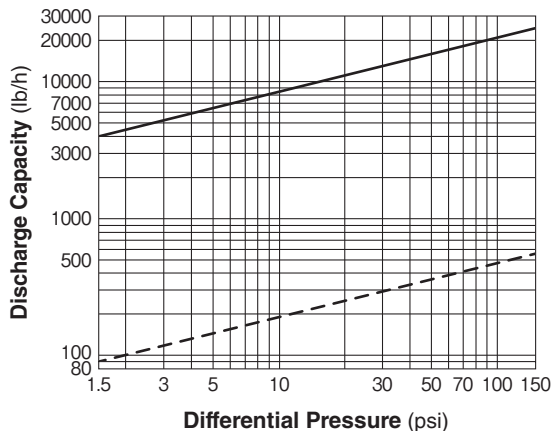

- : Capacity of GT10L as a steam trap (P<sub>1</sub> > P<sub>2</sub>). Instantaneous condensate loads above the rated trap capacity will cause the pump to cycle and therefore reduce the discharge capacity.
- - - : Minimum amount of condensate required to prevent steam leakage.

- Capacities are based on continuous discharge of condensate 11 °F below steam temperature.
- Differential pressure is the difference between the inlet and outlet pressure of the trap.



DO NOT use this product under conditions that exceed maximum differential pressure, as condensate backup will occur!

**System Package**

**Single System Package Type M1L**

Discharge Capacity: see discharge capacity column **A** (no correction factor required)

Tank Size: 6.7 gal

Weight: approx. 288 lb (dry)

Other tank sizes and connections available

**SIDE VIEW**

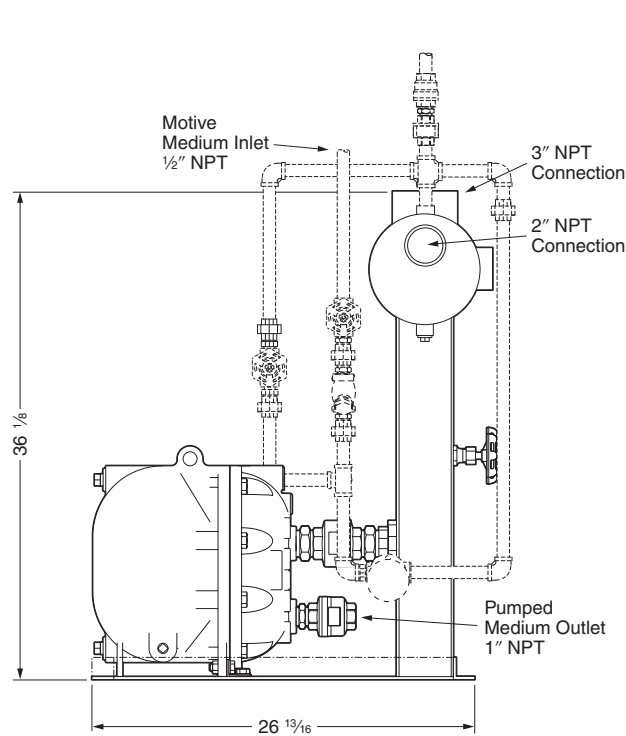

**NOTE:** Piping and valves indicated by dashed lines can be provided at an additional cost.

Inlet: 1/2"

Outlet: 1"

Filling head: 25"

Screwed connections: NPT

Other standards available

Units: inch

**FRONT VIEW**

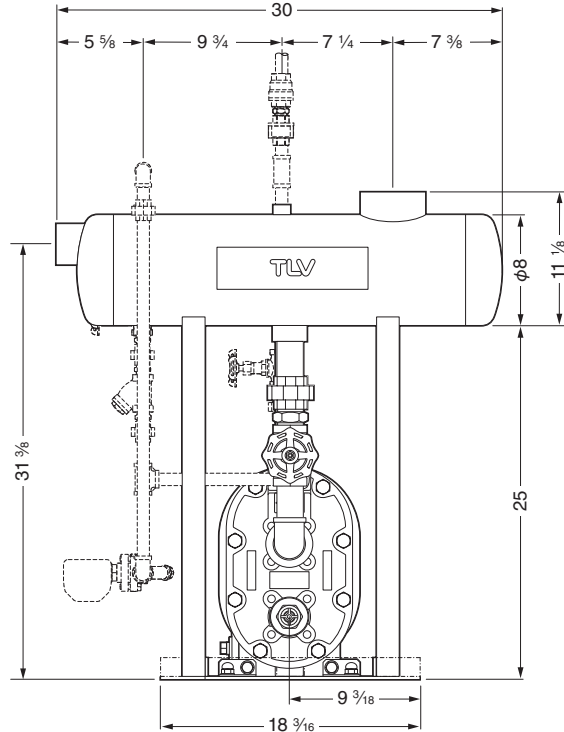

**TOP VIEW**

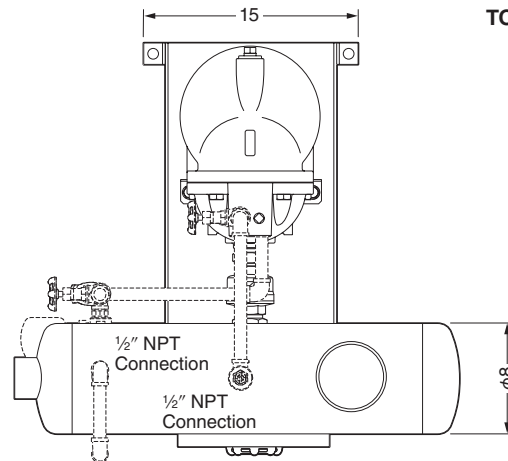

**DO NOT DISASSEMBLE OR REMOVE THIS PRODUCT WHILE IT IS UNDER PRESSURE.** Allow internal pressure of this product to equal atmospheric pressure and its surface to cool to room temperature before disassembling or removing. Failure to do so could cause burns or other injury. **READ INSTRUCTION MANUAL CAREFULLY.**

**TLV CORPORATION**

13901 South Lakes Drive, Charlotte, NC 28273-6790  
 Phone: 704-597-9070 Fax: 704-583-1610  
 E-mail: [tlv@tlvengineering.com](mailto:tlv@tlvengineering.com)  
 For Technical Service 1-800 "TLV TRAP"



Manufacturer  
**TLV CO., LTD.**  
 Kakogawa, Japan  
 is approved by LRQA Ltd. to ISO 9001/14001

ISO 9001/ISO 14001

