

TLV[®]

ThermoDyne[™]

Steam Trap

A3N

Long Life, Best Quality

The most versatile thermodynamic steam trap



The Thermodynamic Steam Trap of Choice for Over Half a Century... Here's Why:

Durability

TLV products are designed from the outset to help minimize life cycle cost. The A3N is quality-made for durability, ensuring long-term stable operation.

Versatility

With its high discharge capacity and pressure range up to 230 psig, the A3N can be used on a wide range of applications – from steam mains to light processes.

Reliability

The predecessor of the A3N, the A3, appeared in 1958. Ten times more durable than conventional traps in its day, this line is a longtime bestseller.

Steam Jacketing



In traps with a single-layer cap, adverse atmospheric conditions and radiant heat loss result in steam loss from no-load actuation and

blowing. While this problem is partly solved with an air-insulated jacket, the A3N's steam-heated and condensate-cooled jacket offers the greatest protection, ensuring the most stable operation of all thermodynamic steam traps.

Mirror-polished Sealing Surfaces

Some valve discs include an air leak pathway or rough finish to prevent air binding. However, this can result in greater surface wear and steam leakage due to

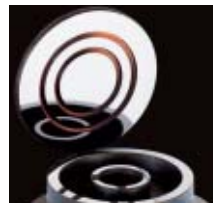

no-load actuation. The A3N solves this problem: the bimetal air vent ring eliminates air binding and allows the hardened sealing surfaces to be mirror-polished, resulting in a tight seal that saves steam.

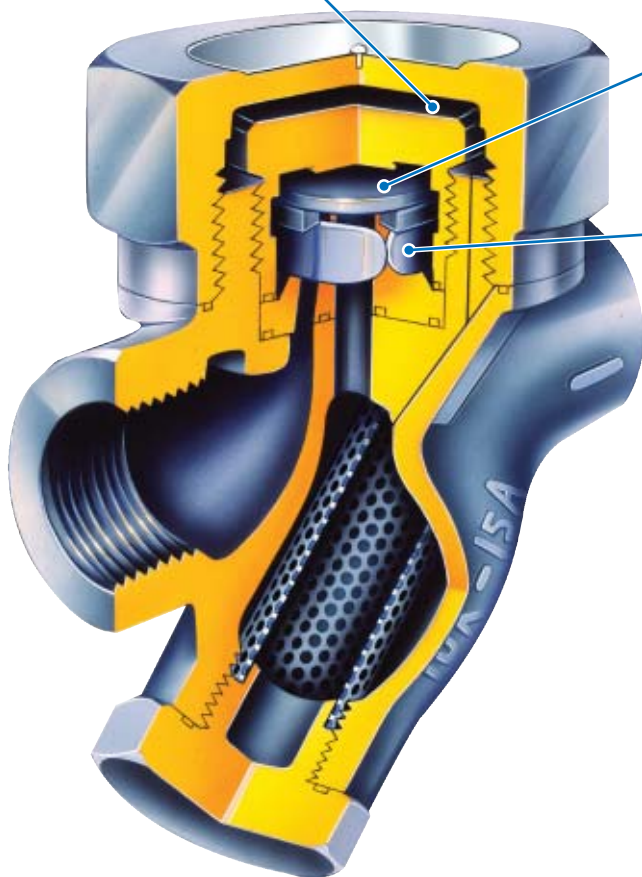

Bimetal Air Vent Ring

To reach full operating efficiency, air and condensate must be purged from steam lines. The bimetal air vent ring quickly and efficiently vents traps for rapid start-up without air binding and makes manual blowdown unnecessary.

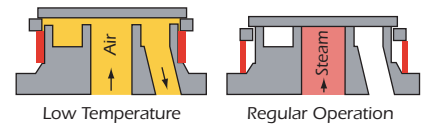

Replaceable Module

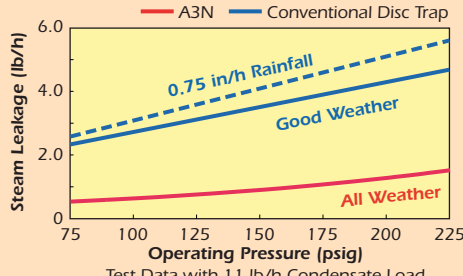
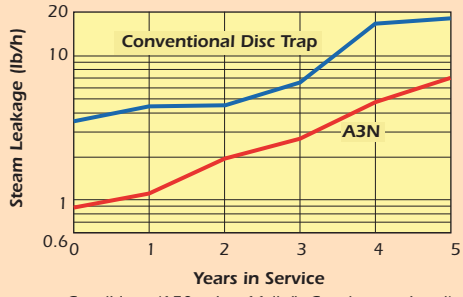
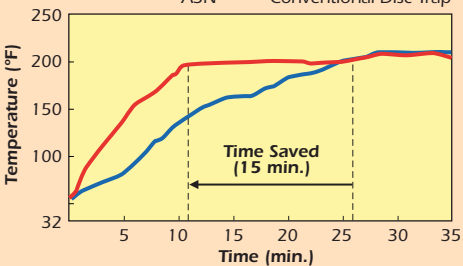

Disc-type steam traps often fail from wear due to the repetitive impact of the valve disc against the valve seat. With the A3N's replaceable module, these parts can easily be replaced as a single unit, reducing replacement time and maintenance costs.

Feature	Benefits	Supporting Data
<p>Steam Jacketing</p>	<p>Energy Conservation Steam loss due to adverse weather conditions such as rain and wind is drastically reduced by the steam jacketed pressure chamber.</p> <p>Fig. 1 A typical disc trap loses more steam when exposed to rain than under fine weather conditions. In contrast, the A3N, with no difference in steam loss due to weather, is virtually unaffected by ambient conditions.</p>	<p>1 Effect of Weather</p>  <p>Test Data with 11 lb/h Condensate Load</p>
<p>Mirror-polished Sealing Surfaces</p>	<p>Long Service Life Internal parts have been developed to provide tight sealing, which reduces wear and prolongs service life.</p> <p>Fig. 2 While a conventional disc trap generates 3.5 lb/h of steam loss when brand new and 6.6 lb/h after three years, the same values for the A3N are only 0.9 lb/h and 2.8 lb/h, respectively.</p>	<p>2 Effect of Wear on Service Life</p>  <p>Conditions (150 psig, 11 lb/h Condensate Load)</p>
<p>Bimetal Air Vent Ring</p>	<p>Increased Productivity Automatic air venting reduces start-up time, greatly improving productivity. Additionally, reductions in steam loss, fuel consumption and labor can be achieved by eliminating the need for manual blowdown at start-up.</p> <p>Fig. 3 Tests indicate that by preventing air binding, the A3N can reduce start-up time by 15 minutes – a reduction of approx. 60%!</p>	<p>3 Comparing Start-up Times</p> 

How it operates

■ Cold condensate
 ■ Hot condensate
 ■ Air
 ■ Steam

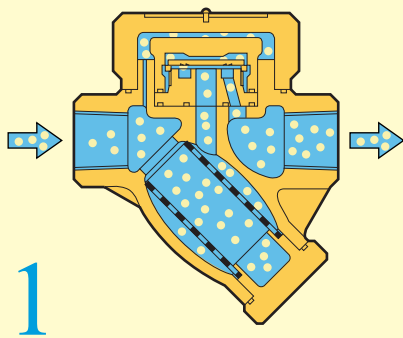

At start-up, the bimetal air vent ring is contracted, lifting the disc off the valve seat and allowing rapid discharge of air and cold condensate.

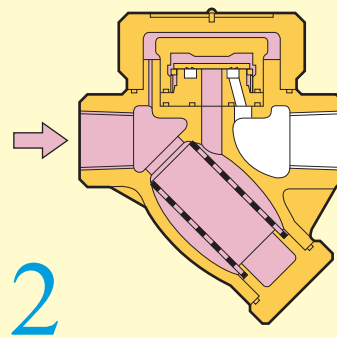

As temperature in the trap rises, the bimetal expands and releases the disc. The disc is forced downward by the low-pressure area created by the rapid flow of flashing condensate/steam below the disc, and the simultaneous high pressure in the pressure chamber above it. A steam jacket insulates the cap's pressure chamber from the radiant heat loss that could cause no-load actuation.

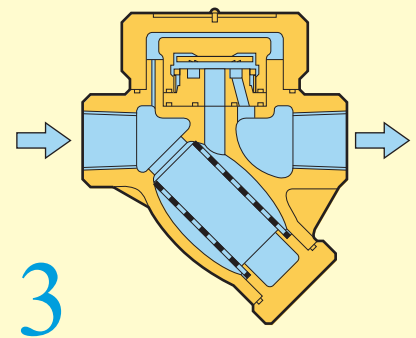

Eventually, the pressure chamber is cooled when condensate enters the space above, lowering the steam pressure in the pressure chamber and thus allowing the inlet pressure to push the disc up and discharge condensate. Entering flashing condensate/steam then closes the trap, as in step 2.

Specifications

Model	A3N
Body Material	Malleable Cast Iron
Connection	Screwed
Size (in)	1/2", 3/4", 1"
Max. Operating Pressure (psig) PMO	230
Min. Operating Pressure (psig)	5
Max. Operating Temperature (°F) TMO	428
Max. Allowable Pressure (psig) PMA	250
Max. Allowable Temperature (°F) TMA	428
Maximum Back Pressure	80% of Inlet Pressure
Air Venting	Automatic Bimetal
Pressure Chamber Insulation	Steam Jacket

Construction

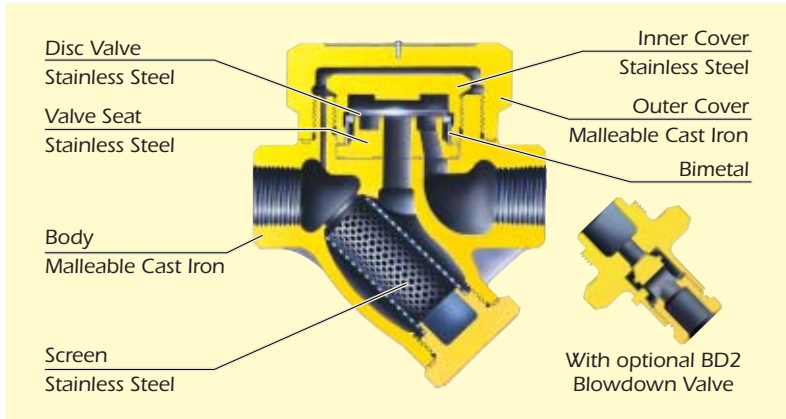

Discharge Capacity

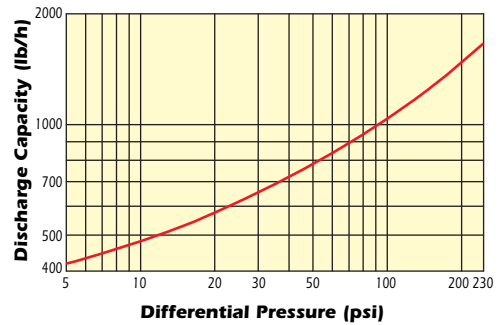

- Differential Pressure is the difference between the inlet and outlet pressure of the trap.
- Recommended safety factor: at least 2.

Application

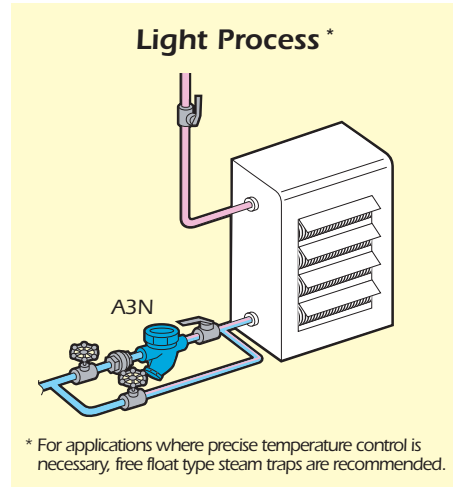
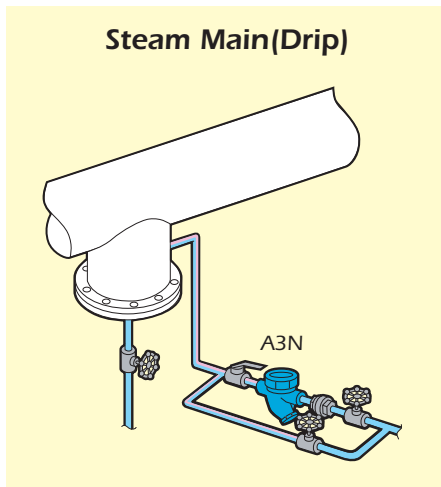
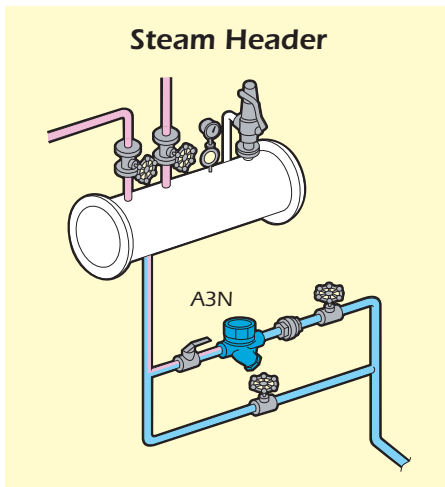

To avoid abnormal operation, accidents or serious injury, DO NOT use this product outside of the specification range. Local regulations may restrict the use of this product to below the conditions quoted.

TLV CORPORATION

13901 South Lakes Drive, Charlotte, NC 28273-6790

Phone: 704-597-9070 Fax: 704-583-1610

E-mail: tlv@tlvengineering.com

For Technical Service 1-800 "TLV TRAP"



Manufacturer
TLV CO., LTD.
Kakogawa, Japan
is approved by LRQA Ltd. to ISO 9001/14001

ISO 9001/ISO 14001

