

TLV[®]

TEMPERATURE CONTROL STEAM TRAPS

LEX3N-TZ

With Built-in Scale Removal Function



Maintain the proper temperature of oils and other fluids in supply piping and heating tanks.

What is a Temperature Control Steam Trap?

Temperature control steam traps can control the temperature of discharged condensate*. Condensate with temperatures above the adjustable set temperature is held back in the piping, allowing the sensible heat in the condensate to be used for various heating applications.

The temperature control trap is useful for maintaining the fluidity of heavy oils, facilitating fluid pumping and transportation, preventing chemical or physical changes in the product due to cooling and preventing water from freezing in transportation pipes in cold areas.

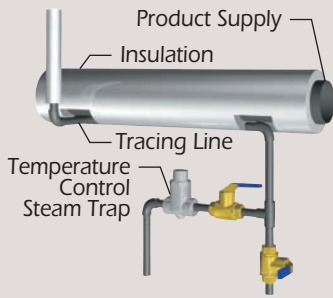

* Temperature of the condensate accumulating in the equipment or pipe and the product temperature cannot be set.

Benefits

1. Maintains temperature at preset levels by adjusting the valve closing temperature.
2. Saves steam by heating the fluid to the optimum temperature utilizing the sensible heat of condensate.
3. No steam leakage.
4. Condensate discharge temperature can be adjusted without disconnecting the trap from the piping.
5. Initial air and cold condensate can be discharged quickly, with no air binding.
6. Scale removal function can eliminate obstructive buildup from the valve seat, even during operation.
7. All stainless construction.
8. The overexpansion mechanism prevents possible damage to the bimetal from superheated steam.
9. Built-in screen ensures trouble-free operation.
10. Easy, inline access to internal parts simplifies cleaning and maintenance.
11. Can be used as an automatic non-freeze valve.
12. Quiet operation.

Construction

LEX3N-TZ

All Stainless Steel

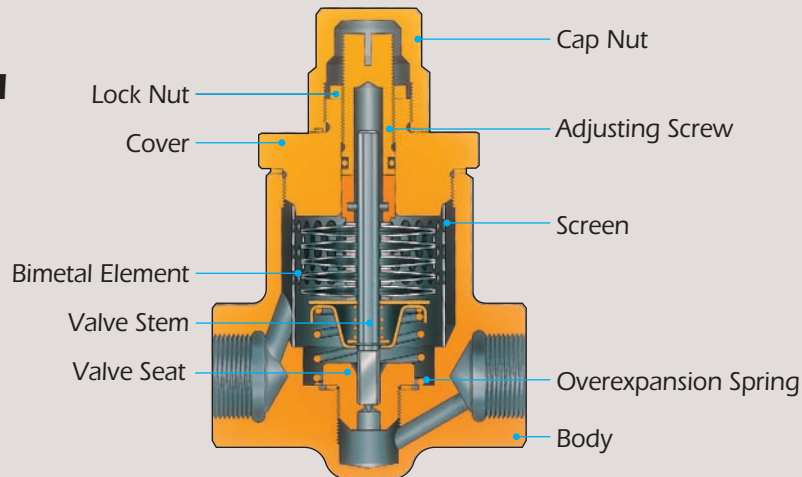

Operation

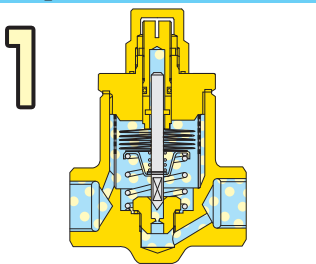

1 At startup, the bimetal element is contracted. The coil spring holds the valve open, quickly discharging the cold air and initial condensate.

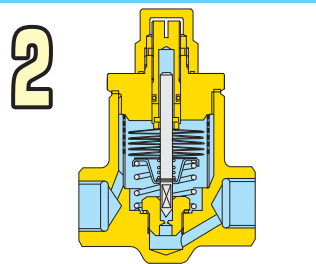

2 When the condensate temperature rises, the bimetal begins to expand. The valve begins to close, allowing less condensate to flow.

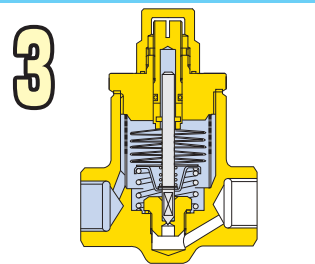

3 When the condensate reaches the preset temperature, the valve shuts tightly, stopping all condensate discharge.

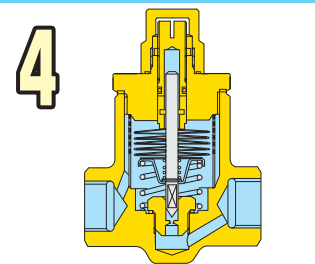

4 When the condensate temperature drops below the preset level, the element contracts. The coil spring opens the valve, allowing condensate to be discharged. Steps 3 and 4 alternate as condensate temperature changes.

Scale Removal Function

Clogs in the valve seat can be eliminated by simply isolating the trap, no need to remove the trap from the line.

The temperature control steam trap used in tracing lines has a small opening in the valve seat designed to reduce the flow velocity – a functional requirement. However, because of this, the possibility of the valve clogging due to the scale and other buildup is higher than for other traps. The scale removal device enables the elimination of obstructions from the valve seat.

Operating Scale Removal Device

1. Using a flat-head screwdriver, turn the adjusting screw. The sharp edge of the valve head shaves off scale and other buildup blocking the valve seat orifice.
2. By raising the adjusting screw, steam or condensate blows off the residue. This also cleans the other surfaces on the valve seat.



Clogging due to Scale



After Cleaning



Not only is the obstruction removed from the orifice, but the surrounding valve seat surface is cleaned as well, a result of loosening the buildup followed by steam and condensate blowdown.

Overexpansion Mechanism

Damage to the bimetal is prevented by the overexpansion mechanism.

Temperature control steam traps function through the deflection of bimetals due to rising or falling temperature, allowing the valve to open and close. Due to the possibility of damage to the bimetal following temperature rises when the valve is already on the seat, the LEX3N-TZ employs a coil spring to allow further expansion of the bimetal while the valve is closed: up to 200 °C above the set value.

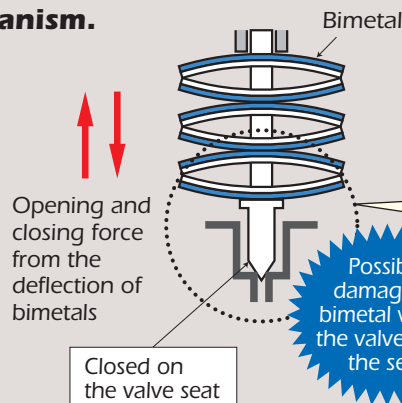

- Exceeding the set temperature

The over-expansion spring absorbs the additional force, protecting the bimetal

Spring Guide
Return Spring

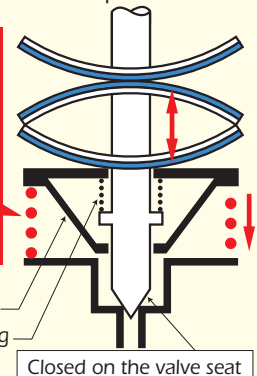

Temperature Setting

The discharge temperature can be adjusted and set to the desired temperature by simply adjusting the screw on the upper part of the LEX3N-TZ with a flat-head screwdriver.

Increasing the set temperature

Turn the screw:

▶ **Counterclockwise**

Decreasing the set temperature

Turn the screw:

▶ **Clockwise**

Standard Factory Setting ("0" Position)

The standard "0" position is the position where point (A), the bottom of the adjusting screw slot is even with point (B), the top surface of the cap threads.

LEX3N-TZ : 100 °C at 0.9 MPaG

From "0" on the graph, adjust the screw to the desired temperature

⊕ : counterclockwise

⊖ : clockwise

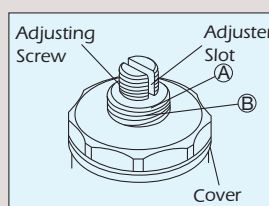

LEX3N-TZ Adjustment chart

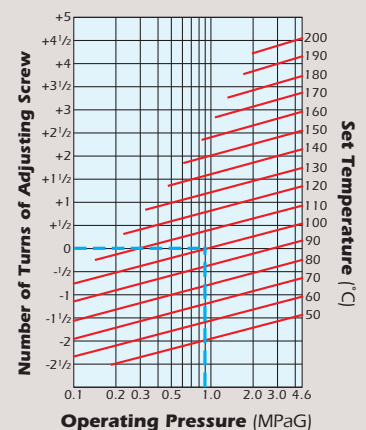

DO NOT REMOVE CAP NUT OR COVER WHILE TRAP IS UNDER PRESSURE. Allow trap body temperature to cool to room temperature before removing cap nut or cover. Failure to do so may result in burns or other injury. READ INSTRUCTION MANUAL CAREFULLY.

Correct Usage of Temperature Control Steam Traps

Examples of Correct Use:

✓ Applications designed to utilize sensible heat of condensate

- **SUITABLE** for steam tracing lines or storage tank coils **ONLY IF** the required product viscosity will be maintained when the condensate is sub-cooled at least 15 °C, even to the point of the condensate having a lower temperature than the product temperature.
- **SUITABLE** for use on instrument enclosures **ONLY IF** the steam or condensate temperature in the enclosures will **NOT** damage the instrument.
- **SUITABLE** for use as an external air vent for TLV steam traps, or as a non-freeze valve for freeze protection of condensate lines.

Example: Steam tracing on an oil supply pipe

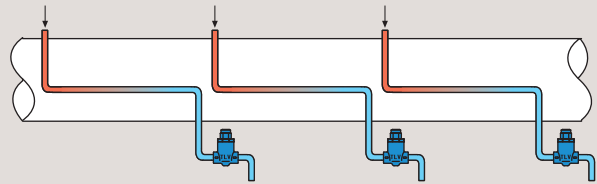

Examples of Incorrect Use:

✗ Applications requiring the rapid removal of condensate or applications designed to use latent heat of steam

- **DO NOT USE** on any application **except** steam tracing lines, storage tank coils, instrument enclosures, steam trap air venting, and freeze protection of condensate lines.
- **NOT SUITABLE FOR USE** on steam tracing lines or storage tank coils **IF** the required product viscosity will **NOT** be maintained when the condensate is sub-cooled at least 15 °C.
- **NOT SUITABLE FOR USE** on steam tracing lines or storage tank coils **IF** the heated product will solidify at temperatures of 80 °C or higher. (e.g., asphalt or sulfur).
- **NOT SUITABLE FOR USE** on steam tracing lines or storage tank coils designed to use only the latent heat of steam to maintain product fluidity at temperatures of 80 °C or less. (e.g., certain heavy oils).

Incorrect use of a temperature control steam trap could lead to significant system problems. Careful consideration is required, bearing the following in mind.

Heating with sensible heat

➔ Temperature control steam trap

Heating with latent heat

➔ General purpose steam trap

Specifications

Model	Connection	Size (mm)	Maximum Operating Pressure (MPaG)	Minimum Operating Pressure (MPaG)	Maximum Operating Temperature (°C)	Condensate Temperature Setting Range (°C)	Maximum Discharge Capacity** (kg/h)
LEX3N-TZ	Screwed	10, 15, 20, 25	4.6	0.1	350	50 - 200*	440
	Socket Welded						
	Flanged	15, 20, 25					

1 MPa = 10.197 kg/cm²

* Set temperature should be more than 15 °C below the steam saturation temperature; see graph, right

** Actual discharge capacity will vary depending on operating conditions; see specification data sheet (SDS) for details

PRESSURE SHELL CONDITIONS (**NOT** OPERATING CONDITIONS): Maximum Allowable Pressure (MPaG) PMA: 6.3
Maximum Allowable Temperature (°C) TMA: 425

The trap may be installed either horizontally or vertically. However, when installing horizontally, make sure that the trap is installed with the temperature adjusting screw positioned higher than the piping in which the trap is installed. (Upside-down installation is not permissible.)



To avoid abnormal operation, accidents or serious injury, DO NOT use this product outside the specification range. Local regulations may restrict the use of this product to below the conditions quoted.

Temperature Setting Range

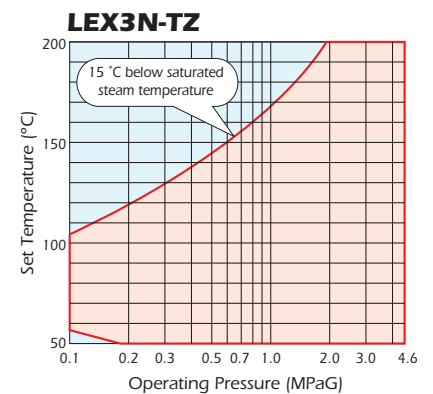

TLV INTERNATIONAL, INC.

881 Nagasuna, Noguchi, Kakogawa, Hyogo 675-8511, JAPAN
Tel: [81]-(0)79-427-1818 Fax: [81]-(0)79-425-1167
E-mail: tlv-japan@tlv.co.jp <http://www.tlv.com>

Manufacturer
TLV CO., LTD.
Kakogawa, Japan
is approved by LRQA Ltd. to ISO 9001/14001

