



# PROCESS LEVER FLOAT STEAM TRAP MODEL SW1U-A/SW1U-B

ULTRA HIGH-CAPACITY CARBON STEEL STEAM TRAP WITH UNIQUE LEVER FLOAT MECHANISM

## Features

Super heavy duty process lever float steam trap ideal for quickly and instantaneously draining very large quantities of condensate from process machinery, utilizing TLV's unique TLY® (Tetra-Leaf & Yoke) construction.

1. TLY construction enables massive discharge capacity with a compact design.
2. Stable operation with long service life due to durable materials.
3. Suitable for continuously operating equipment using large quantities of steam, such as reboilers or large heat exchangers.
4. Valve opening adjusts according to the amount of in-flowing condensate, reducing steam loss and condensate accumulation in the steam-using equipment.

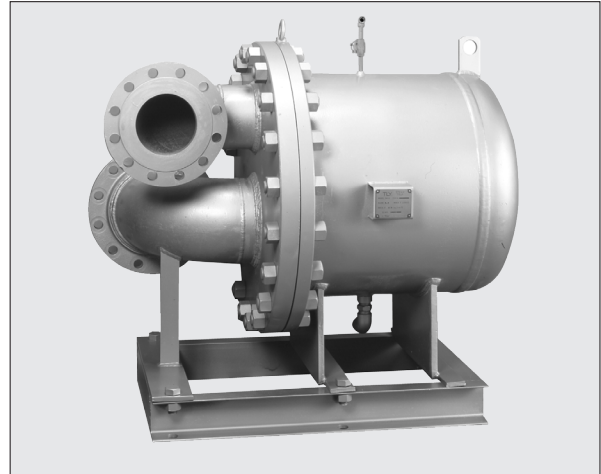

## Specifications

Model	SW1U-A	SW1U-B
Body Material	Carbon Steel STPG370/S25C	Carbon Steel SB410/S25C
Size (mm)	80, 100	100, 150, 200
Connection	Flanged	
Maximum Operating Pressure (MPaG)	PMO	1.6
Maximum Differential Pressure (MPa)	ΔPMX	0.4 (0.2*)
Maximum Operating Temperature (°C)	TMO	220

\* For water below 100 °C

1 MPa = 10.197 kg/cm<sup>2</sup>

PRESSURE SHELL DESIGN CONDITIONS (**NOT OPERATING CONDITIONS**): Maximum Allowable Pressure (MPaG) PMA: 1.6  
Maximum Allowable Temperature (°C) TMA: 220



To avoid abnormal operation, accidents or serious injury, DO NOT use this product outside of the specification range. Local regulations may restrict the use of this product to below the conditions quoted.

No.	Description	Material	JIS	ASTM/AISI*
①	Body Unit	SW1U-A Carbon Steel	S25C/STPG370	AISI1025/A53 Type S Gr.A
		SW1U-B Carbon Steel	S25C/SB410	AISI1025/A515 Gr.60
②	Cover Unit	Stainless Steel/Carbon Steel	—	—
③	Valve Seat Body	Cast Stainless Steel	—	A351 Gr.CF8
④	TLY Valve	Stainless Steel	SUS303	AISI303
⑤	Float Unit	Stainless Steel	SUS316L	AISI316L
⑥	Seal Ring	Stainless Steel	SUS303	AISI303
⑦	Bearing	Stainless Steel	SUS303	AISI303
⑧	Valve Holder	Stainless Steel	SUS303	AISI303
⑨	Valve Holder Bolt	Stainless Steel	SUS304	AISI304
⑩	Lever Bolt	Stainless Steel	SUS304	AISI304
⑪	Spring Washer	Stainless Steel	SUS304	AISI304
⑫	Valve Seat Body Gasket	Fluorine Resin	PTFE	PTFE
⑬	Cover Gasket	Graphite/Stainless Steel	-/SUS304	-/AISI304
⑭	Cover Bolt	Alloy Steel	SNB7	A193 Gr.B7
⑮	Cover Nut	Carbon Steel	S45C	AISI1045
⑯	Baffle	Stainless Steel	SUS304	AISI304
⑰	Valve Seat Body Bolt	Stainless Steel	SUS304	AISI304
⑱	Drain Plug	Malleable Cast Iron	FCMB	A47 Gr.32510
⑲	Mounting Base	Carbon Steel	SS400	A6
⑳	Wave Spring	Stainless Steel	SUS301	AISI301
㉑	Bellows Sealed Valve	Carbon Steel	—	A105
㉒	Nameplate	Stainless Steel	SUS304	AISI304
㉓	Mounting Bolt	Carbon Steel	SS400	A6
㉔	Mounting Nut	Carbon Steel	SS400	A6
㉕	Spring Washer	Carbon Steel	SWRH57	AISI1055
㉖	Washer	Carbon Steel	SS400	A6
㉗	Foundation Bolt	Carbon Steel	SS400	A6
㉘	Set Screw	Stainless Steel	SUS304	AISI304
㉙	Eye Bolt	Carbon Steel	SS400	A6

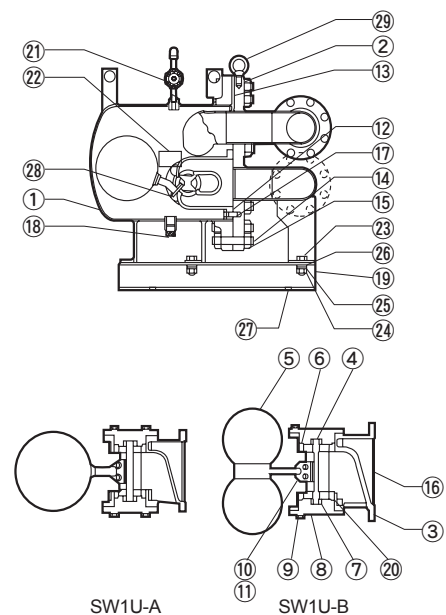

Install outlet piping leading from the bellows valve to a drainage vessel or ditch and make sure the end of the pipe is above the waterline.

\* Equivalent

**Dimensions**

● SW1U-A/SW1U-B Flanged

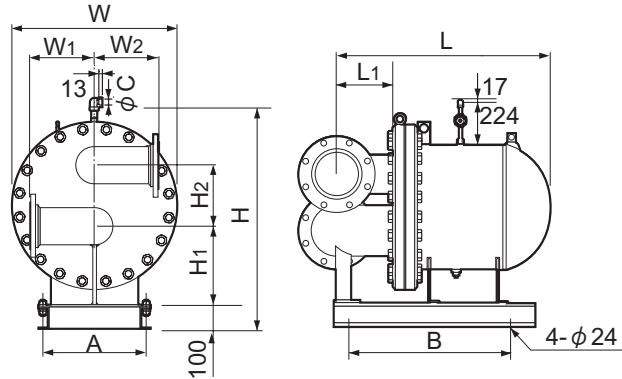

SW1U-A/SW1U-B Flanged (mm)

Model	Size	ASME Class	L	L <sub>1</sub>	H	H <sub>1</sub>	H <sub>2</sub>	W	W <sub>1</sub> /W <sub>2</sub>	A	B	C	Weight (kg)
SW1U-A	80	150RF	760	220	895	280	195	595	200	335	500	21.8	265
		300RF	780					650					300
	100	150RF	760					595					270
		300RF	780					650					325
SW1U-B	100	150RF	950	250	995	365	260	750	300	480	650	21.8	570
		300RF	970					1070					395
	150	150RF	950		995	365		750					580
		300RF	970		1070	395		840					745
	200	150RF	950		995	365		750					615
		300RF	970		1070	395		840					770

Other standards available, but length and weight may vary

**TLY® Construction**

TLY® (Tetra-Leaf & Yoke) construction was developed for process lever float steam traps, and comprises a four-bladed valve connected directly to a lever float.

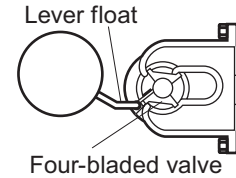

As the valve opening and closing forces created by the pressure differential between inlet and outlet pressures are balanced, a four-bladed valve ensures stable trap operation at all times.

TLY is a registered trademark of TLV CO., LTD.

**Discharge Capacity**

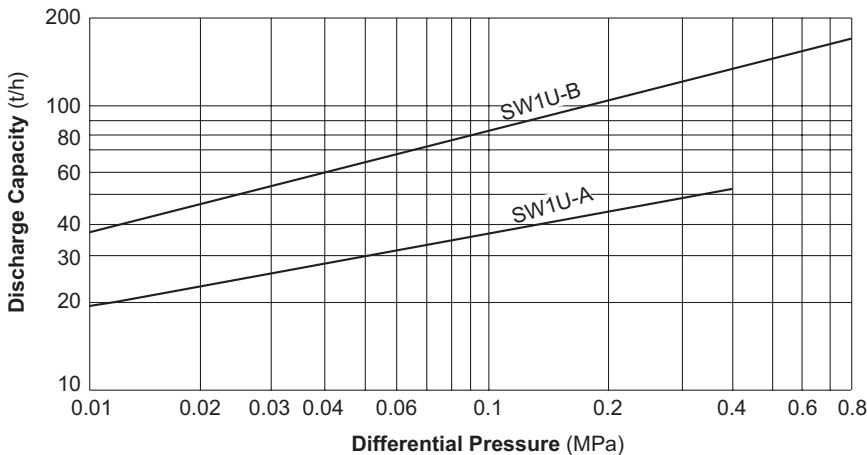

1. Line numbers within the graph are orifice numbers.
2. Differential pressure is the difference between the inlet and outlet pressure of the trap.
3. Capacities are based on continuous discharge of condensate 6 °C below saturated steam temperature.
4. Recommended safety factor: at least 1.5.



DO NOT use traps under conditions that exceed maximum differential pressure, as condensate backup will occur!

Manufacturer  
**TLV** CO., LTD.  
 Kakogawa, Japan  
 is approved by LRQA Ltd. to ISO 9001/14001

