

TLV[®]

Cyclone Separators

DC Series



CONDENSATE ENTRAINED IN STEAM AND AIR WILL BE REMOVED WITH 98% EFFICIENCY.

CONSTRUCTION (DC3S)

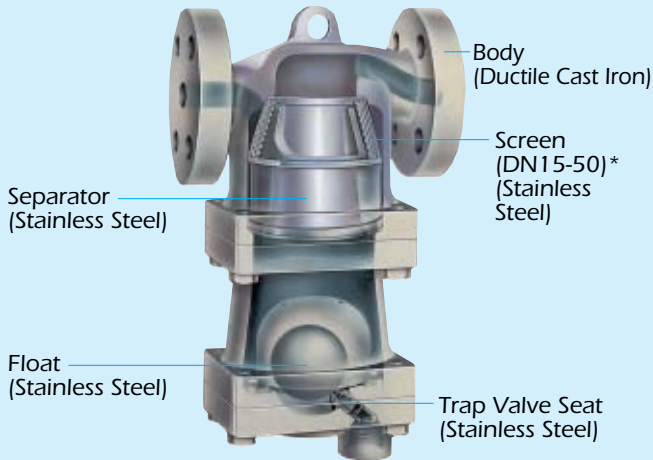

* Screen for sizes DN 65-100 is in Trap Cover

FEATURES AND BENEFITS

1. Cyclone-Effects Separator:

- Provides condensate separation efficiency as high as 98%.
- Improves productivity and product quality with dry, high-quality steam/air.

2. Free-Float Trap: (DC7 needs a separate trap)

- Continuously discharges condensate as it is separated.
- Provides a complete seal, even under no load conditions, with its precision ground spherical float and positive three-point seating.

OPERATION

During Separation

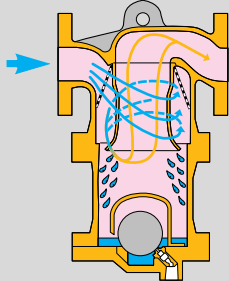

1 Fluid enters the inlet of the separator, and a complex series of fins changes the steam or air flow into a high-speed cyclone flow, separating even mist-like condensate.

During Discharge

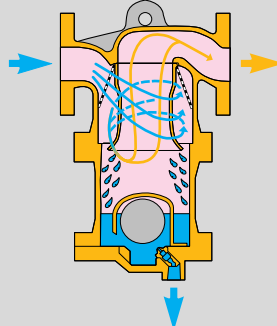

2 The separated condensate accumulates at the bottom, lifting the float off the valve seat and discharging condensate continuously.

FLOW VELOCITY AND EFFICIENCY

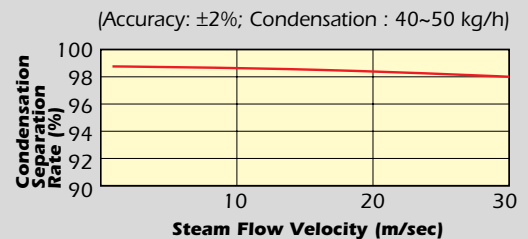

Separation rate (%) is given as:

$$\frac{\text{quantity of condensate discharged}}{\text{quantity of incoming condensate}} \times 100$$

SPECIFICATIONS

Model	Type	Connection	Sizes	Body Material	Orifice No. (Built-in Trap)	Max. Operating Pressure (barg) PMO	Max. Differential Pressure (bar) ΔPMX (Built-in Trap)	Max. Operating Temperature(°C) TMO
	DC3S Steam Separator Trap	Screwed	1/2", 3/4", 1"	Ductile Cast Iron	21	21	21	220
		Flanged	DN 15, 20, 25, 40, 50, 65, 80, 100					
	DC3A Air Separator Trap	Screwed	1/2", 3/4", 1"	Cast Iron	10	10	10	100
		Flanged	DN 15, 20, 25, 40, 50, 65, 80, 100	Ductile Cast Iron				
	DC7 Steam/Air Separator	Screwed	1/2", 3/4", 1", 1 1/2", 2"	Stainless Steel	-	25	-	300
		Socket Welded	DN 15, 20, 25,					
		Flanged	40, 50					

PRESSURE SHELL DESIGN CONDITIONS (**NOT** OPERATING CONDITIONS):

Maximum Allowable Pressure (barg) PMA: 13 (DC3A-Screwed), 21 (DC3A-Flanged, DC3S), 25 (DC7)
 Maximum Allowable Temperature (°C) TMA: 200 (DC3A-Screwed), 220 (DC3A-Flanged, DC3S), 300 (DC7)

Do not use for toxic, flammable or otherwise hazardous fluids.

1 bar = 0.1 MPa



To avoid abnormal operation, accidents or serious injury, DO NOT use this product outside of the specification range. Local regulations may restrict the use of this product to below the conditions quoted.

TLV EURO ENGINEERING UK LTD.

Units 7 & 8, Furlong Business Park, Bishops Cleeve, Gloucestershire GL52 8TW, UK
 Tel: [44]-(0)1242-227223 Fax: [44]-(0)1242-223077

Manufacturer

TLV CO., LTD.

Kakogawa, Japan

is approved by LRQA Ltd. to ISO 9001/14001

ISO 9001/ISO 14001

