



Manufacturer

TLV. CO., LTD.

Kakogawa, Japan

is approved by LRQA LTD. to ISO 9001/14001



Instruction Manual

Balanced Pressure Thermostatic Steam Trap

LV5 • LV5C

LV13 • LV13C • LV13L • LV13N

LV21 • LV21C

LV21-TC

Contents

Introduction.....	1
Safety Considerations.....	2
Checking the Piping.....	4
Specifications	5
Configuration	6
Installation	7
Maintenance.....	8
Disassembly / Reassembly.....	9
Troubleshooting.....	13
Product Warranty.....	14

Introduction

Thank you for purchasing the **TLV** Balanced Pressure Thermostatic Steam Trap.

This product has been thoroughly inspected before being shipped from the factory. When the trap is delivered, before doing anything else, check the specifications and external appearance to make sure nothing is out of the ordinary. Also be sure to read this manual carefully before use and follow the instructions to be sure of using the trap properly.

This steam trap is of a revolutionary design that uses a high-performance X-element. This is a new type of valve mechanism in which a thermoliquid is sealed inside the X-element and the valve opens or closes based on the difference between the saturation temperatures of the thermoliquid and the water. The X-element is very sensitive to changes in temperature, and responds with great accuracy, quickly discharging air and the large quantities of condensate created immediately after operation start-up, thereby greatly reducing start-up time. It also reacts with great sensitivity to the inflow of large quantities of condensate and hot air during operation, preventing air-locking.

The superior features of the X-element help increase heating efficiency and reduce manpower requirements for maintenance and bypass blowdown.





If detailed instructions for special order specifications or options not contained in this manual are required, please contact **TLV** for full details.

This instruction manual is for the models listed on the front cover. It is needed not only for installation, but also for subsequent maintenance, disassembly/reassembly and troubleshooting. Please keep it in a safe place for future reference.

Safety Considerations

- Read this section carefully before use and be sure to follow the instructions.
- Installation, inspection, maintenance, repairs, disassembly, adjustment, and valve opening/closing should be carried out only by trained maintenance personnel.
- The precautions listed in this manual are designed to ensure safety and prevent equipment damage and personal injury. For situations that may occur as a result of erroneous handling, three different types of cautionary items are used to indicate the degree of urgency and the scale of potential damage and danger: DANGER, WARNING and CAUTION.
- The three types of cautionary items above are very important for safety: be sure to observe all of them as they relate to installation, use, maintenance, and repair. Furthermore, TLV accepts no responsibility for any accidents or damage occurring as a result of failure to observe these precautions.

Symbols

	Indicates a DANGER, WARNING or CAUTION item.
	Indicates an urgent situation which poses a threat of death or serious injury
	Indicates that there is a potential threat of death or serious injury
	Indicates that there is a possibility of injury or equipment / product damage

	DO NOT use this product outside the recommended operating pressure, temperature and other specification ranges. Improper use may result in such hazards as damage to the product or malfunctions that may lead to serious accidents. Local regulations may restrict the use of this product to below the conditions quoted.
	Take measures to prevent people from coming into direct contact with product outlets. Failure to do so may result in burns or other injury from the discharge of fluids.
	When disassembling or removing the product, wait until the internal pressure equals atmospheric pressure and the surface of the product has cooled to room temperature. Disassembling or removing the product when it is hot or under pressure may lead to discharge of fluids, causing burns, other injuries or damage.
	Be sure to use only the recommended components when repairing the product, and NEVER attempt to modify the product in any way. Failure to observe these precautions may result in damage to the product and burns or other injury due to malfunction or the discharge of fluids.

Safety cautions continued on next page.

 CAUTION	Do not use excessive force when connecting threaded pipes to the product. Over-tightening may cause breakage leading to fluid discharge, which may cause burns or other injury.
	Use only under conditions in which no freeze-up will occur. Freezing may damage the product, leading to fluid discharge, which may cause burns or other injury.
	Use only under conditions in which no water hammer will occur. The impact of water hammer may damage the product, leading to fluid discharge, which may cause burns or other injury.

Checking the Piping



Use only under conditions in which no water hammer will occur. The impact of water hammer may damage the product, leading to fluid discharge, which may cause burns or other injury.

Check to make sure that the pipes to be connected to the trap have been installed properly.

1. Is the pipe diameter suitable?
2. Is the piping where the trap is to be installed horizontal?
3. Has sufficient space been secured for maintenance?
4. Have isolation valves been installed at the inlet and outlet? If the outlet is subject to back pressure, has a check valve (TLV-CK) been installed?
5. Is the inlet pipe as short as possible, with as few bends as possible, and installed so the liquid will flow naturally down into the trap?
6. Has the piping work been done correctly, as shown in the figures below?

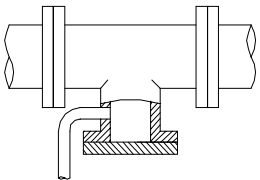
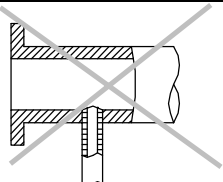
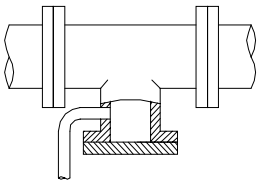
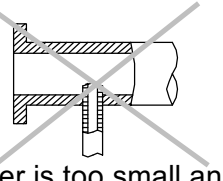
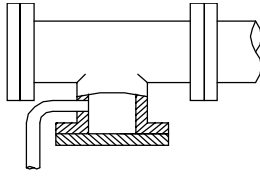
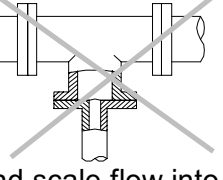
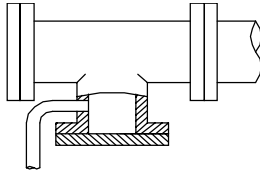
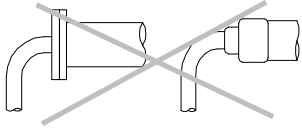
Requirement	Correct	Incorrect
Install catchpot with the proper diameter.		 Diameter is too small.
Make sure the flow of condensate is not obstructed.		 Diameter is too small and inlet protrudes into pipe interior.
To prevent rust and scale from flowing into the trap, the inlet pipe should be connected 25 – 50 mm above the base of the T-pipe.		 Rust and scale flow into the trap with the condensate.
When installing on the blind end, make sure the flow of condensate is not obstructed.		 Condensate collects in the pipe.

Specifications



DO NOT use this product outside the recommended operating pressure, temperature and other specification ranges. Improper use may result in such hazards as damage to the product or malfunctions which may lead to serious accidents. Local regulations may restrict the use of this product to below the conditions quoted.



Use only under conditions in which no freeze-up will occur. Freezing may damage the product, leading to fluid discharge, which may cause burns or other injury.

Refer to the product nameplate for detailed specifications.

LV13L • LV13N

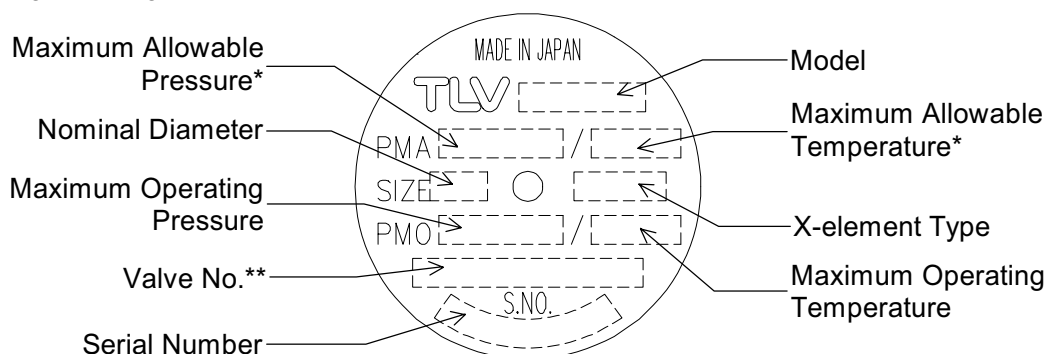

LV5 • LV5C / LV13 • LV13C / LV21 • LV21C / LV21-TC

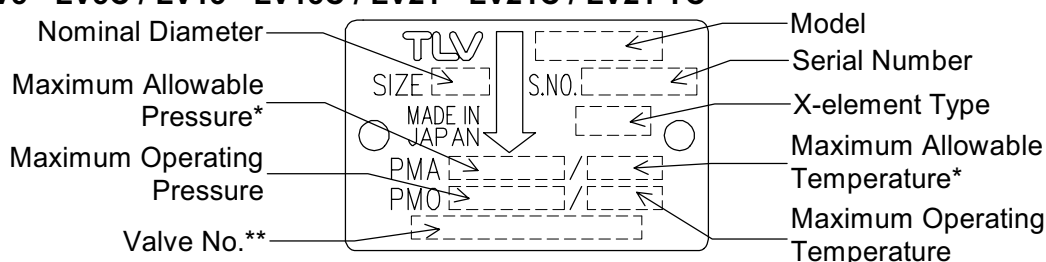

* Maximum allowable pressure (PMA) and maximum allowable temperature (TMA) are PRESSURE SHELL DESIGN CONDITIONS, **NOT** OPERATING CONDITIONS.

** Valve No. is displayed for products with options. This item is omitted from the nameplate when there are no options.

Maximum Operating Temperature (stainless steel models):

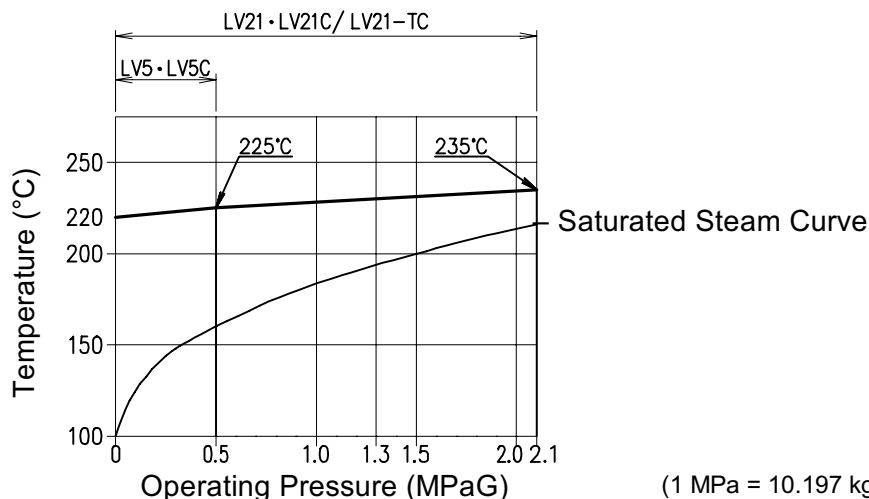

(1 MPa = 10.197 kg/cm²)

Configuration

LV5 • LV5C / LV13 • LV13C (Brass)

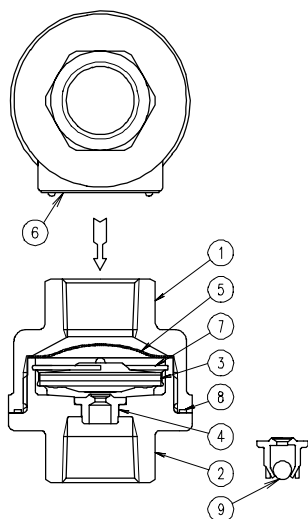

No.	Name
1	Body
2	Cover
3	X-element
4	Valve Seat
5	Screen
6	Nameplate
7	Spring Clip
8	Cover Gasket
9*	Check Valve Ball

* LV5C, LV13C only

LV21-TC (Cast Stainless Steel)

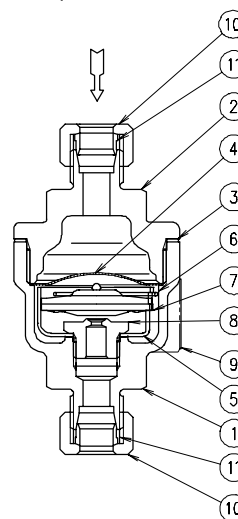

LV5 • LV5C / LV21 • LV21C (Cast Stainless Steel)

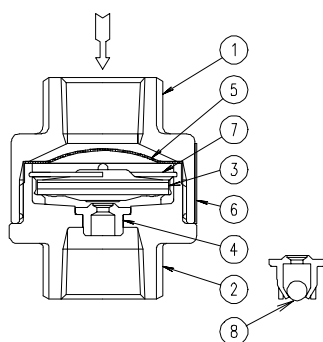

No.	Name
1	Body
2	Cover
3	X-element
4	Valve Seat
5	Screen
6	Nameplate
7	Spring Clip
8*	Check Valve Ball

* LV5C, LV21C only

No.	Name	R**
1	Body	
2	Cover	
3	Cover Gasket	✓
4	Screen	✓
5	X-element Guide	✓
6	Spring Clip	✓
7	X-element	✓
8	Valve Seat	✓
9	Nameplate	
10	Sleeve Nut (×2)	✓
11	Sleeve (×2)	✓

LV13L (Brass)

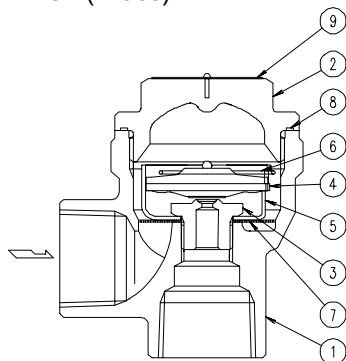

No.	Name	R**
1	Body	
2	Cover	
3	Valve Seat	✓
4	X-element	✓
5	X-element Guide	✓
6	Spring Clip	✓
7	Screen	✓
8	Cover Gasket	✓
9	Nameplate	

LV13N (Brass)

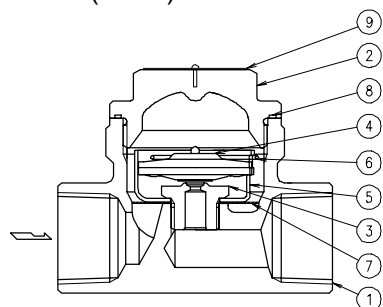

No.	Name	R**
1	Body	
2	Cover	
3	Valve Seat	✓
4	X-element	✓
5	X-element Guide	✓
6	Spring Clip	✓
7	Screen	✓
8	Cover Gasket	✓
9	Nameplate	✓

** Parts available in repair kit

Installation



Take measures to prevent people from coming into direct contact with product outlets. Failure to do so may result in burns or other injury from the discharge of fluids.



Do not use excessive force when connecting threaded pipes to the product. Over-tightening may cause breakage leading to fluid discharge, which may cause burns or other injury.

Installation, inspection, maintenance, repairs, disassembly, and adjustment should be done only by trained maintenance personnel.

1. Before installation, be sure to remove all protective seals.
2. Before installing the trap, blow out the inlet piping to remove any piping scraps, dirt and oil. Close the inlet valve after blowdown.
3. Install with the arrow on the product pointing in the direction of flow.
4. All models except LV13L may be installed either vertically or horizontally, whichever is necessary to make sure the arrow on the product points in the direction of flow. DO NOT install traps upside-down. Model LV13L **MUST** be installed with the inlet horizontal and the outlet vertical.
5. Connect the piping.
6. Open the inlet valve and check to make sure that the trap functions properly.
7. LV21-TC Instructions:
 - Connect to pipe sections that are not scratched or deformed.
 - When cutting pipes, make straight cuts perpendicular to the pipe length. Remove any pipe scraps or dirt.
 - Reconnection: Compression fitting attachment allows repeated disconnection and reattachment.
 - Refer to the following table proper compression fitting torque

LV21-TC Compression Fitting Torque

Pipe Diameter (mm)	8	10	9.53 (3/8")	12.7 (1/2")
Tightening Torque (N·m)	46	56	53	98
Distance Across Flats (mm)	17	19	21	24

1 N·m ≈ 10 kg·cm

If there is a problem, determine the cause by using the "Troubleshooting" guide in this manual.

Maintenance



Take measures to prevent people from coming into direct contact with product outlets. Failure to do so may result in burns or other injury from the discharge of fluids.



Be sure to use only the recommended components when repairing the product, and NEVER attempt to modify the product in any way. Failure to observe these precautions may result in damage to the product or burns or other injury due to malfunction or the discharge of fluids.

Operational Check

A visual inspection of the following items should be done on a daily basis to determine whether the trap is operating properly or has failed. Periodically (at least biannually) the operation should also be checked by using diagnostic equipment, such as a stethoscope, thermometer, TLV PenCheck or TLV TrapMan.

If the trap should fail, it may cause damage to piping and equipment, resulting in faulty or low quality products or losses due to steam leakage.

- Normal : Condensate is discharged intermittently together with flash steam, and the sound of flow can be heard.
- Blocked (Discharge Impossible) : No condensate is discharged. The trap is quiet and makes no noise, and the surface temperature of the trap is low.
- Blowing : Live steam continually flows from the outlet and there is a continuous metallic sound.
- Steam Leakage : Live steam is discharged through the trap outlet together with condensate, accompanied by a high-pitched sound.

(When conducting a visual inspection, flash steam is sometimes mistaken for steam leakage. For this reason, the use of a steam trap diagnostic instrument [such as TLV TrapMan if appropriate] in conjunction with the visual inspection is highly recommended.)

Parts Inspection

When parts have been removed, or during periodic inspections, use the following table to inspect the parts and replace any that are found to be defective.

Procedure	
Gasket:	Check for warping or damage
Screen:	Check for clogging or corrosion damage
X-element:	Check for damage
Valve seat:	Check for damage
Check inside of body for rust and scale	
Check X-element valve and valve seat for rust and scale or oil film, and also check for wear	

Disassembly / Reassembly



When disassembling or removing the product, wait until the internal pressure equals atmospheric pressure and the surface of the product has cooled to room temperature. Disassembling or removing the product when it is hot or under pressure may lead to discharge of fluids, causing burns, other injuries or damage.

Use the following procedures to remove components. Use the same procedure in reverse to reassemble. (Installation, maintenance, repairs, disassembly, and adjustment should be done only by trained maintenance personnel.)

Removing / Reattaching Body (LV5 • LV5C / LV13 • LV13C / LV21 • LV21C)

Part	During Disassembly	During Reassembly
Body	Use a socket wrench to remove	Consult the table of tightening torques and tighten to the proper torque

Removing / Reassembling Parts Inside Cover

(LV5 • LV5C / LV13 • LV13C / LV21 • LV21C)

Part	During Disassembly	During Reassembly
Screen	Remove without bending	Being careful not to bend it, insert with the right side up
Spring Clip	Remove with needle-nose pliers	Fit securely into the spring clip slots
X-element	Remove from the X-element guide	Holding the ball on the top of the X-element with pliers, insert slowly, keeping the X-element level and making sure it does not catch on the guide (Fig. A)
Cover Gasket*	Remove carefully to avoid damaging	Replace with new gasket when necessary

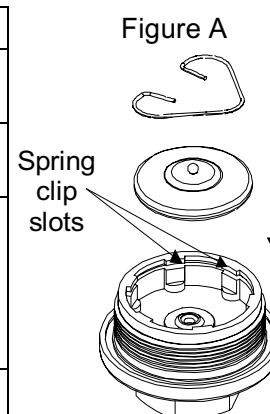

* Only for brass LV5, LV5C, LV13 and LV13C

Table of Tightening Torques (LV5 • LV5C / LV13 • LV13C / LV21 • LV21C)

Part	Size mm	Torque N·m	Distance Across Flats mm
Body / Cover (Brass) (LV5, LV5C, LV13, LV13C)	8 – 15	80	27
	20, 25	80	41
Body / Cover (Stainless Steel) (LV5, LV5C, LV21, LV21C)	8 – 15	120	27

Note: Be sure to coat screw threads with anti-seize only on stainless steel models of LV5, LV5C, LV21 and LV21C

1 N·m ≈ 10 kg·cm

Removing / Reattaching Cover (LV13L • LV13N / LV21-TC)

Part	During Disassembly	During Reassembly
Cover	Remove with a socket wrench	Consult the table of tightening torques and tighten to the proper torque
Cover Gasket	Remove carefully to avoid damaging	Replace with new gasket when necessary

Removing / Reassembling Parts Inside Body (LV13L • LV13N / LV21-TC)

Part	During Disassembly	During Reassembly
Spring Clip	Remove with needle-nose pliers or by hand	Fit securely into the spring clip slots (Figure B)
X-element	Grasp the ball on the top of the X-element with pliers and remove	Holding the ball on the top of the X-element with pliers, insert slowly, keeping the X-element level and making sure it does not catch on the guide (Figure C)
Valve Seat	Remove with a socket wrench	Consult the table of tightening torques and tighten to the proper torque
X-element Guide	Remove without bending	Insert the X-element carefully
Screen	Remove without bending	Insert without bending

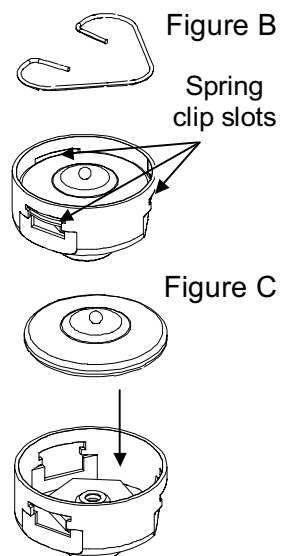
**Table of Tightening Torques** (LV13L • LV13N / LV21-TC)

Part	Torque N·m	Distance Across Flats mm
Cover (LV13L, LV13N)	80	32
Cover (LV21-TC)	300	27
Valve Seat	35	19

1 N·m ≈ 10 kg·cm

Note: LV13L • LV13N: **DO NOT** coat screw threads with anti-seize.

LV21-TC: Coat threads and cover gasket with anti-seize.

Exploded View

LV5 • LV5C / LV13 • LV13C
(Brass)

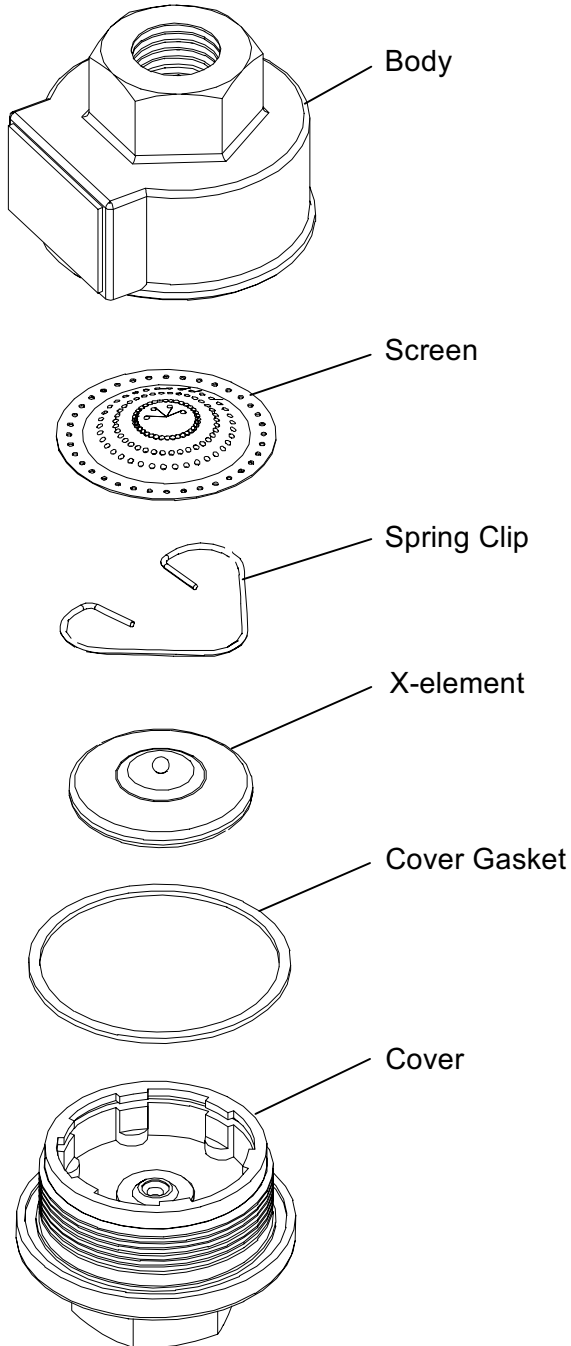

LV5 • LV5C / LV21 • LV21C
(Stainless Steel)

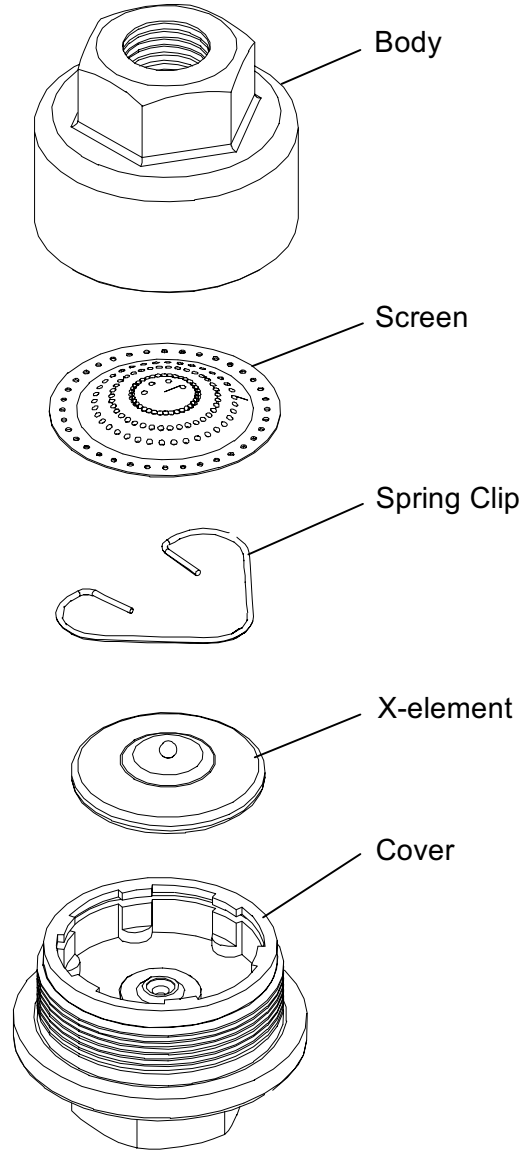

Exploded View

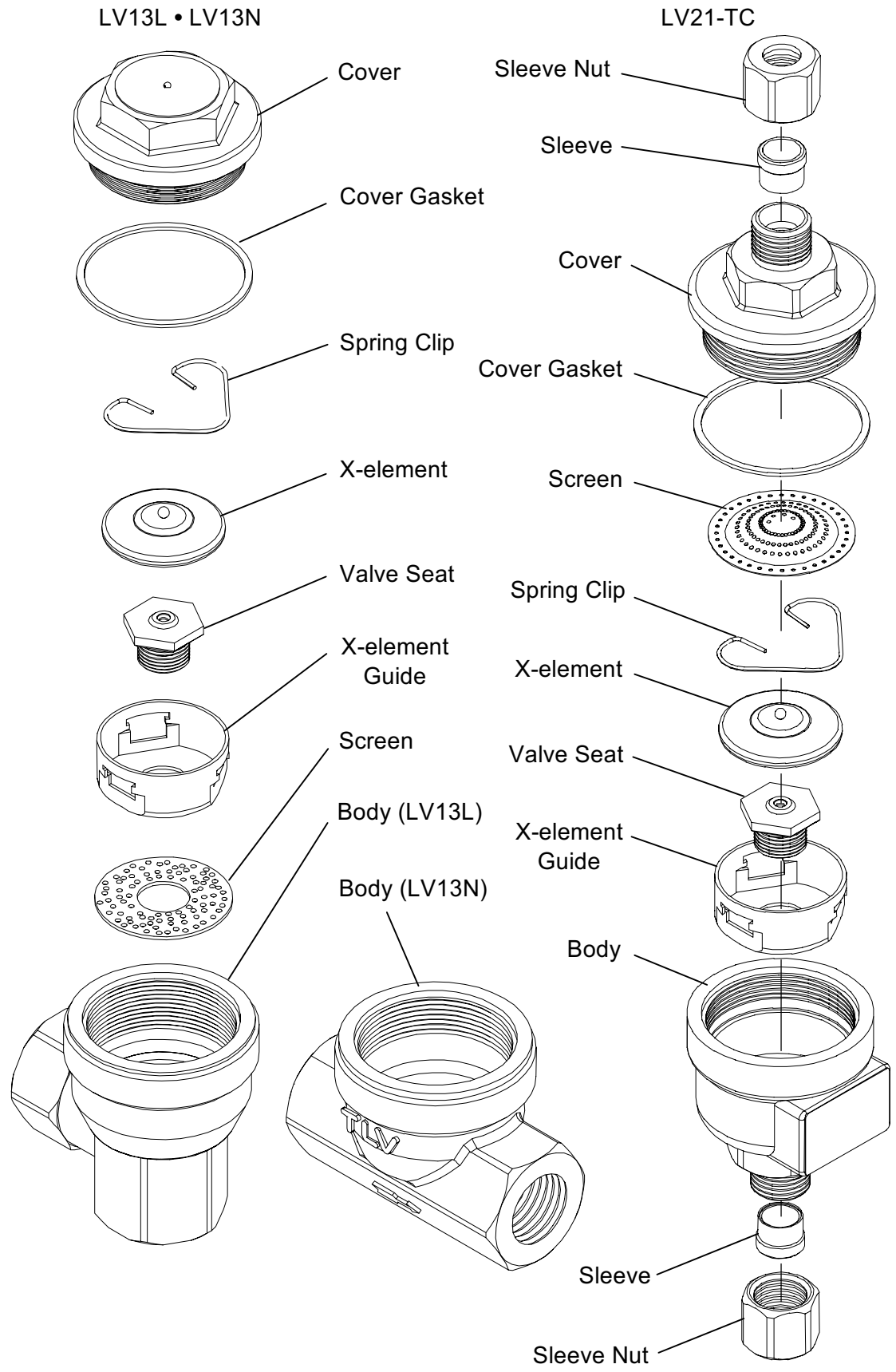

Troubleshooting



When disassembling or removing the product, wait until the internal pressure equals atmospheric pressure and the surface of the product has cooled to room temperature. Disassembling or removing the product when it is hot or under pressure may lead to discharge of fluids, causing burns, other injuries or damage.

When the trap fails to operate properly, use the following table to locate the cause.

Problem	Cause	Remedy
No condensate is discharged or discharge is poor (blocked)	The X-element is sticking to the valve seat	Clean parts
	The valve seat is blocked	Clean or replace valve seat
	The screen is clogged with rust or scale	Clean parts
	The trap operating pressure exceeds the maximum specified pressure or there is insufficient pressure differential between the trap inlet and outlet	Compare specifications and actual operating conditions
Steam is discharged or leaks from the outlet (blowing) (steam leakage)	There is rust or scale build-up between the X-element valve and valve seat	Clean parts
	The X-element valve and/or valve seat are worn or damaged	Replace X-element and/or valve seat/cover
	The X-element is broken	Replace X-element
	Improper installation	Correct the installation
	Severe trap vibration occurs	Lengthen inlet piping and fasten securely
Steam is leaking from a place other than the outlet	The cover gasket has deteriorated or is damaged	Replace with new gasket
	Improper tightening torques were used	Tighten to the proper torque

Product Warranty

1. Warranty Period
One year following product delivery.
2. Warranty Coverage
TLV CO., LTD. warrants this product to the original purchaser to be free from defective materials and workmanship. Under this warranty, the product will be repaired or replaced at our option, without charge for parts or labor.
3. This product warranty will not apply to cosmetic defects, nor to any product whose exterior has been damaged or defaced; nor does it apply in the following cases:
 - 1) Malfunctions due to improper installation, use, handling, etc., by other than TLV CO., LTD. authorized service representatives.
 - 2) Malfunctions due to dirt, scale, rust, etc.
 - 3) Malfunctions due to improper disassembly and reassembly, or inadequate inspection and maintenance by other TLV CO., LTD. authorized service representatives.
 - 4) Malfunctions due to disasters or forces of nature.
 - 5) Accidents or malfunctions due to any other cause beyond the control of TLV CO., LTD.
4. Under no circumstances will TLV CO., LTD. be liable for consequential economic loss damage or consequential damage to property.

* * * * *

For Service or Technical Assistance:
Contact your **TLV** representative or your regional **TLV** office.

Manufacturer

TLV CO., LTD.
881 Nagasuna, Noguchi
Kakogawa, Hyogo 675-8511 JAPAN
Tel: 81-(0)794 - 27 - 1800